



DC COMPONENTS CO., LTD.

RECTIFIER SPECIALISTS

**FR301
THRU
FR307**

TECHNICAL SPECIFICATIONS OF FAST RECOVERY RECTIFIER

VOLTAGE RANGE - 50 to 1000 Volts

CURRENT - 3.0 Amperes

FEATURES

- * Fast switching
- * Low leakage
- * Low forward voltage drop
- * High current capability
- * High current surge
- * High reliability

MECHANICAL DATA

- * Case: Molded plastic
- * Epoxy: UL 94V-0 rate flame retardant
- * Lead: MIL-STD-202E, Method 208 guaranteed
- * Mounting position: Any
- * Weight: 1.18 grams



DO-27

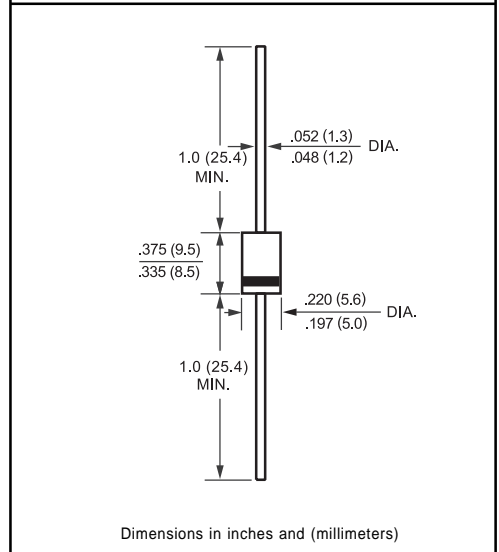

Dimensions in inches and (millimeters)

MAXIMUM RATINGS AND ELECTRICAL CHARACTERISTICS

Ratings at 25°C ambient temperature unless otherwise specified.
Single phase, half wave, 60 Hz, resistive or inductive load.
For capacitive load, derate current by 20%.

	SYMBOL	FR301	FR302	FR303	FR304	FR305	FR306	FR307	UNITS
Maximum Recurrent Peak Reverse Voltage	VRRM	50	100	200	400	600	800	1000	Volts
Maximum RMS Voltage	VRMS	35	70	140	280	420	560	700	Volts
Maximum DC Blocking Voltage	VDC	50	100	200	400	600	800	1000	Volts
Maximum Average Forward Rectified Current at TA= 75°C	Io	3.0							Amps
Peak Forward Surge Current 8.3 ms single half sine-wave superimposed on rated load (JEDEC Method)	IFSM	200							Amps
Maximum Instantaneous Forward Voltage at 3.0A DC	VF	1.3							Volts
Maximum DC Reverse Current at Rated DC Blocking Voltage TA = 25°C	IR	10							uAmps
Maximum Full Load Reverse Current Average, Full Cycle .375*(9.5mm) lead length at T L = 55°C		150							uAmps
Maximum Reverse Recovery Time (Note 1)	trr	150				250	500		nSec
Typical Junction Capacitance (Note 2)	CJ	65							pF
Operating and Storage Temperature Range	TJ, TSTG	-65 to + 150							°C

NOTES : 1. Test Conditions: IF = 0.5A, IR = 1.0A, IRR = 0.25A
2. Measured at 1 MHz and applied reverse voltage of 4.0 volts

RATING AND CHARACTERISTIC CURVES (FR301 THRU FR307)

FIG. 1 - TYPICAL FORWARD CURRENT DERATING CURVE

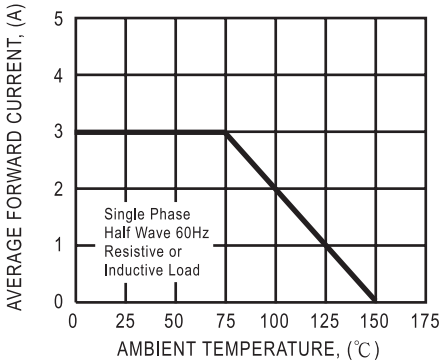

FIG. 2 - MAXIMUM NON-REPETITIVE FORWARD SURGE CURRENT

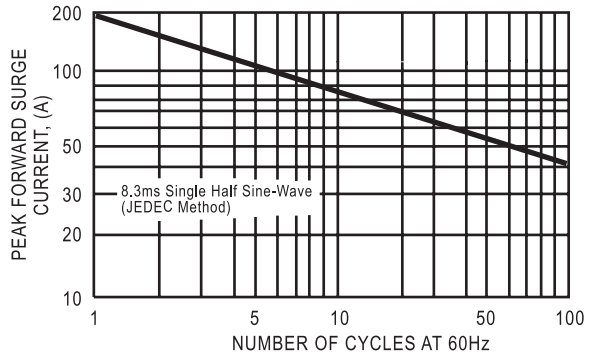

FIG. 3 - TYPICAL INSTANTANEOUS FORWARD CHARACTERISTICS

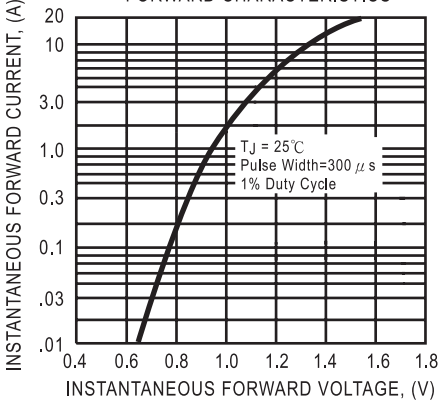

FIG. 4 - TYPICAL JUNCTION CAPACITANCE

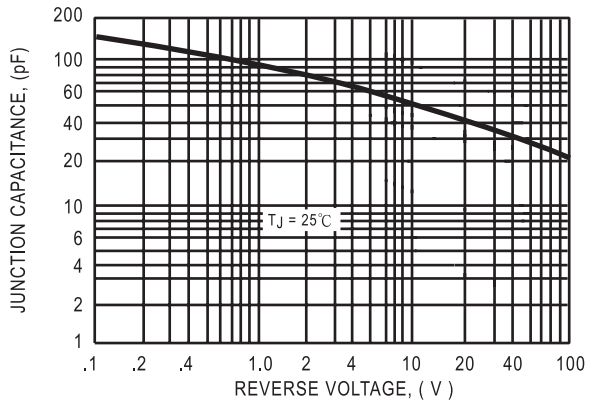
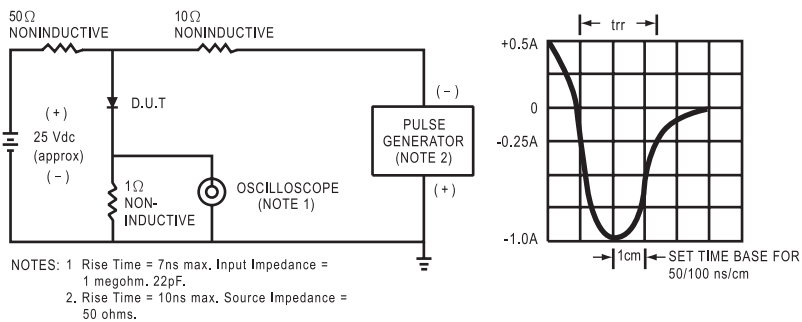

FIG. 5 - TEST CIRCUIT DIAGRAM AND REVERSE RECOVERY TIME CHARACTERISTIC



DC COMPONENTS CO., LTD.