



THREE TERMINAL POSITIVE VOLTAGE REGULATORS
5V, 6V, 8V, 9V, 10V, 12V, 15V, 18V, 24V.

FEATURES

- Suitable for C-MOS, TTL, the Other Digital IC's Power Supply.
- Internal Thermal Overload Protection.
- Internal Short Circuit Current Limiting.
- Output Current in Excess of 1A.
- Satisfies IEC-65 Specification. (International Electronical Commission).

MAXIMUM RATINGS (Ta=25°C)

CHARACTERISTIC		SYMBOL	RATING	UNIT
Input Voltage	FR7805 ~ FR7815	V _{IN}	35	V
	FR7818 ~ FR7824		40	
Power Dissipation (Tc=25°C)		P _{D (TO-220AB)}	20.8	W
Power Dissipation (Without Heatsink)		P _{D (TO-220AB)}	1.5	W
Operating Junction Temperature		T _j	-40 ~ 125	°C
Storage Temperature		T _{stg}	-55 ~ 150	°C

BLOCK DIAGRAM

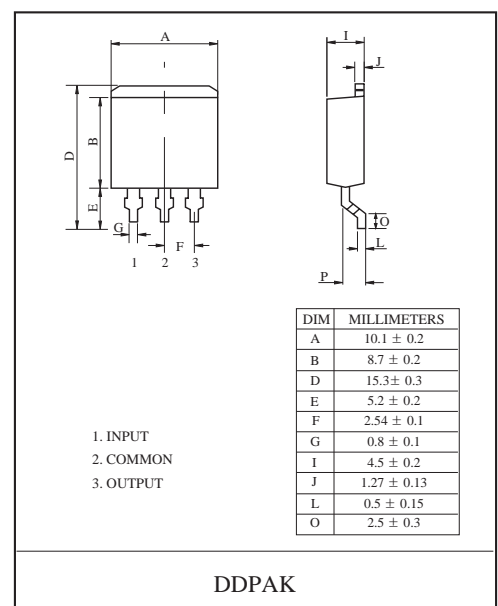
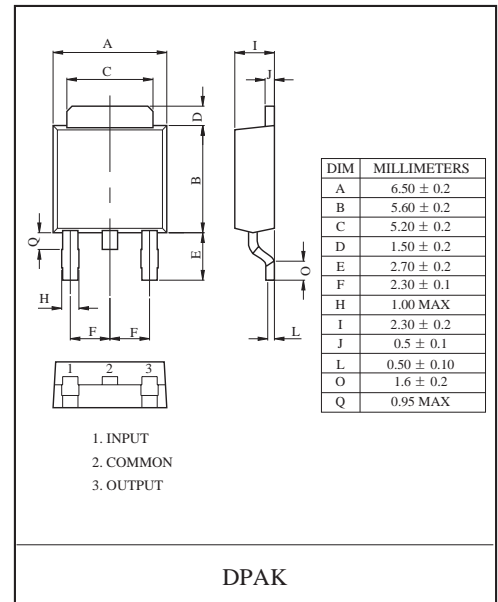
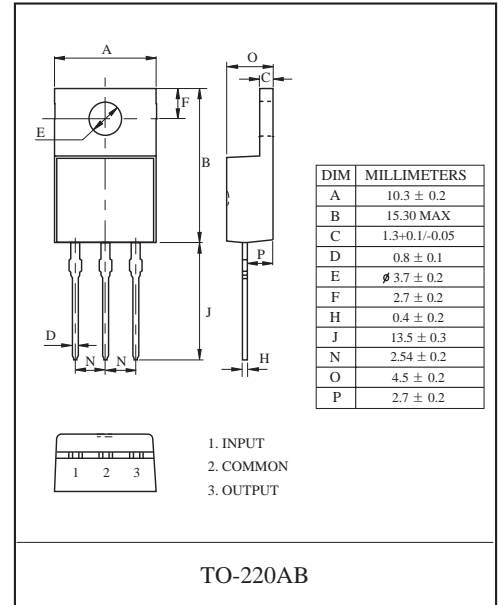
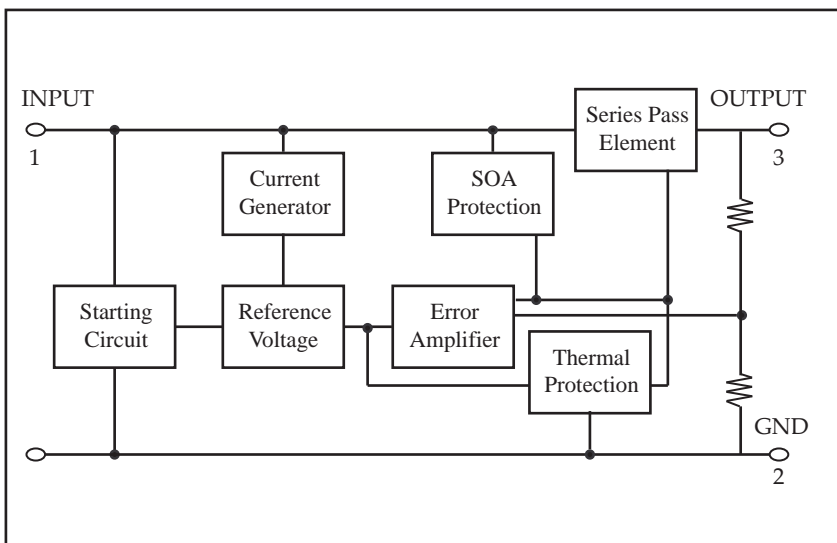



FR7805P/D/DD ~ FR7824P/D/DD

FR7805P/D/DD

ELECTRICAL CHARACTERISTICS ($V_{IN}=10V$, $I_{OUT}=500mA$, $0^{\circ}C \leq T_j \leq 125^{\circ}C$)

CHARACTERISTIC	SYMBOL	TEST CIRCUIT	TEST CONDITION	MIN.	TYP.	MAX.	UNIT	
Output Voltage	V_{OUT}	1	$T_j=25^{\circ}C$, $I_{OUT}=100mA$	4.8	5.0	5.2	V	
			$7.0V \leq V_{IN} \leq 20V$ $5.0mA \leq I_{OUT} \leq 1.0A$, $P_o \leq 15W$	4.75	-	5.25		
Input Regulation	Reg line	1	$T_j=25^{\circ}C$	$7.0V \leq V_{IN} \leq 25V$	-	3	100	mV
				$8.0V \leq V_{IN} \leq 12V$	-	1	50	
Load Regulation	Reg load	1	$T_j=25^{\circ}C$	$5mA \leq I_{OUT} \leq 1.4A$	-	9	100	mV
				$250mA \leq I_{OUT} \leq 750mA$	-	4	50	
Quiescent Current	I_B	1	$T_j=25^{\circ}C$, $I_{OUT}=5mA$	-	4.2	8.0	mA	
Quiescent Current Change	ΔI_B	1	$7.0V \leq V_{IN} \leq 25V$	-	0.3	1.3	mA	
Output Noise Voltage	V_{NO}	1	$T_a=25^{\circ}C$, $10Hz \leq f \leq 100kHz$ $I_{OUT}=50mA$	-	50	-	μV_{rms}	
Ripple Rejection Ratio	RR	1	$f=120Hz$, $8.0V \leq V_{IN} \leq 18V$, $I_{OUT}=50mA$, $T_j=25^{\circ}C$	62	73	-	dB	
Dropout Voltage	V_D	1	$I_{OUT}=1.0A$, $T_j=25^{\circ}C$	-	2.0	-	V	
Short Circuit Current Limit	I_{SC}	1	$T_j=25^{\circ}C$	-	230	-	mA	
Average Temperature Coefficient of Output Voltage	TC_{VO}	1	$I_{OUT}=5mA$, $0^{\circ}C \leq T_j \leq 125^{\circ}C$	-	-0.8	-	mV/ $^{\circ}C$	



FR7805P/D/DD ~ FR7824P/D/DD

FR7806P/D/DD

ELECTRICAL CHARACTERISTICS ($V_{IN}=11V$, $I_{OUT}=500mA$, $0^{\circ}C \leq T_j \leq 125^{\circ}C$)

CHARACTERISTIC	SYMBOL	TEST CIRCUIT	TEST CONDITION	MIN.	TYP.	MAX.	UNIT	
Output Voltage	V_{OUT}	1	$T_j=25^{\circ}C$, $I_{OUT}=100mA$	5.75	6.0	6.25	V	
			$8V \leq V_{IN} \leq 21V$ $5.0mA \leq I_{OUT} \leq 1.0A$, $P_o \leq 15W$	5.7	-	6.3		
Input Regulation	Reg line	1	$T_j=25^{\circ}C$	$8.0V \leq V_{IN} \leq 25V$	-	4	120	mV
				$9V \leq V_{IN} \leq 13V$	-	2	60	
Load Regulation	Reg load	1	$T_j=25^{\circ}C$	$5mA \leq I_{OUT} \leq 1.4A$	-	9	120	mV
				$250mA \leq I_{OUT} \leq 750mA$	-	3	60	
Quiescent Current	I_B	1	$T_j=25^{\circ}C$, $I_{OUT}=5mA$	-	5	8.0	mA	
Quiescent Current Change	ΔI_B	1	$8V \leq V_{IN} \leq 25V$	-	-	1.3	mA	
Output Noise Voltage	V_{NO}	1	$T_a=25^{\circ}C$, $10Hz \leq f \leq 100kHz$ $I_{OUT}=50mA$	-	45	-	μV_{rms}	
Ripple Rejection Ratio	RR	1	$f=120Hz$, $9V \leq V_{IN} \leq 19V$, $I_{OUT}=50mA$, $T_j=25^{\circ}C$	61	75	-	dB	
Dropout Voltage	V_D	1	$I_{OUT}=1.0A$, $T_j=25^{\circ}C$	-	2.0	-	V	
Short Circuit Current Limit	I_{SC}	1	$T_j=25^{\circ}C$	-	250	-	mA	
Average Temperature Coefficient of Output Voltage	TC_{VO}	1	$I_{OUT}=5mA$, $0^{\circ}C \leq T_j \leq 125^{\circ}C$	-	-0.7	-	mV/ $^{\circ}C$	



FR7805P/D/DD ~ FR7824P/D/DD

FR7808P/D/DD

ELECTRICAL CHARACTERISTICS ($V_{IN}=14V$, $I_{OUT}=500mA$, $0^{\circ}C \leq T_j \leq 125^{\circ}C$)

CHARACTERISTIC	SYMBOL	TEST CIRCUIT	TEST CONDITION	MIN.	TYP.	MAX.	UNIT	
Output Voltage	V_{OUT}	1	$T_j=25^{\circ}C$, $I_{OUT}=100mA$	7.7	8.0	8.3	V	
			$10.5V \leq V_{IN} \leq 23V$ $5.0mA \leq I_{OUT} \leq 1.0A$, $P_o \leq 15W$	7.6	-	8.4		
Input Regulation	Reg line	1	$T_j=25^{\circ}C$	$10.0V \leq V_{IN} \leq 25V$	-	6	160	mV
				$11V \leq V_{IN} \leq 17V$	-	2	80	
Load Regulation	Reg load	1	$T_j=25^{\circ}C$	$5mA \leq I_{OUT} \leq 1.4A$	-	12	160	mV
				$250mA \leq I_{OUT} \leq 750mA$	-	4	80	
Quiescent Current	I_B	1	$T_j=25^{\circ}C$, $I_{OUT}=5mA$	-	4.3	8.0	mA	
Quiescent Current Change	ΔI_B	1	$10.5V \leq V_{IN} \leq 25V$	-	0.5	1.0	mA	
Output Noise Voltage	V_{NO}	1	$T_a=25^{\circ}C$, $10Hz \leq f \leq 100kHz$ $I_{OUT}=50mA$	-	52	-	μV_{rms}	
Ripple Rejection Ratio	RR	1	$f=120Hz$, $11.5V \leq V_{IN} \leq 21.5V$, $I_{OUT}=50mA$, $T_j=25^{\circ}C$	56	74	-	dB	
Dropout Voltage	V_D	1	$I_{OUT}=1.0A$, $T_j=25^{\circ}C$	-	2.0	-	V	
Short Circuit Current Limit	I_{SC}	1	$T_j=25^{\circ}C$	-	230	-	mA	
Average Temperature Coefficient of Output Voltage	TC_{VO}	1	$I_{OUT}=5mA$, $0^{\circ}C \leq T_j \leq 125^{\circ}C$	-	-0.8	-	mV/ $^{\circ}C$	



FR7805P/D/DD ~ FR7824P/D/DD

FR7809P/D/DD

ELECTRICAL CHARACTERISTICS ($V_{IN}=15V$, $I_{OUT}=500mA$, $0^{\circ}C \leq T_j \leq 125^{\circ}C$)

CHARACTERISTIC	SYMBOL	TEST CIRCUIT	TEST CONDITION	MIN.	TYP.	MAX.	UNIT	
Output Voltage	V_{OUT}	1	$T_j=25^{\circ}C$, $I_{OUT}=100mA$	8.65	9.0	9.35	V	
			$11.5V \leq V_{IN} \leq 26V$ $5.0mA \leq I_{OUT} \leq 1.0A$, $P_o \leq 15W$	8.6	9.0	9.4		
Input Regulation	Reg line	1	$T_j=25^{\circ}C$	$11.5V \leq V_{IN} \leq 26V$	-	7.0	180	mV
				$13V \leq V_{IN} \leq 19V$	-	2.5	90	
Load Regulation	Reg load	1	$T_j=25^{\circ}C$	$5mA \leq I_{OUT} \leq 1.4A$	-	12	180	mV
				$250mA \leq I_{OUT} \leq 750mA$	-	4.0	90	
Quiescent Current	I_B	1	$T_j=25^{\circ}C$, $I_{OUT}=5mA$	-	4.3	8.0	mA	
Quiescent Current Change	ΔI_B	1	$11.5V \leq V_{IN} \leq 26V$	-	-	1.3	mA	
Output Noise Voltage	V_{NO}	1	$T_a=25^{\circ}C$, $10Hz \leq f \leq 100kHz$ $I_{OUT}=50mA$	-	58	-	μV_{rms}	
Ripple Rejection Ratio	RR	1	$f=120Hz$, $12.5V \leq V_{IN} \leq 22.5V$, $I_{OUT}=50mA$, $T_j=25^{\circ}C$	56	71	-	dB	
Dropout Voltage	V_D	1	$I_{OUT}=1.0A$, $T_j=25^{\circ}C$	-	2.0	-	V	
Short Circuit Current Limit	I_{SC}	1	$T_j=25^{\circ}C$	-	250	-	mA	
Average Temperature Coefficient of Output Voltage	TC_{VO}	1	$I_{OUT}=5mA$, $0^{\circ}C \leq T_j \leq 125^{\circ}C$	-	-1	-	mV/ $^{\circ}C$	



FR7805P/D/DD ~ FR7824P/D/DD

FR7810P/D/DD

ELECTRICAL CHARACTERISTICS ($V_{IN}=16V$, $I_{OUT}=500mA$, $0^{\circ}C \leq T_j \leq 125^{\circ}C$)

CHARACTERISTIC	SYMBOL	TEST CIRCUIT	TEST CONDITION	MIN.	TYP.	MAX.	UNIT	
Output Voltage	V_{OUT}	1	$T_j=25^{\circ}C$, $I_{OUT}=100mA$	9.6	10.0	10.4	V	
			$12.5V \leq V_{IN} \leq 25V$ $5.0mA \leq I_{OUT} \leq 1.0A$, $P_o \leq 15W$	9.5	-	10.5		
Input Regulation	Reg line	1	$T_j=25^{\circ}C$	$12.5V \leq V_{IN} \leq 27V$	-	8	200	mV
				$14V \leq V_{IN} \leq 20V$	-	2.5	100	
Load Regulation	Reg load	1	$T_j=25^{\circ}C$	$5mA \leq I_{OUT} \leq 1.4A$	-	12	200	mV
				$250mA \leq I_{OUT} \leq 750mA$	-	4	100	
Quiescent Current	I_B	1	$T_j=25^{\circ}C$, $I_{OUT}=5mA$	-	4.3	8.0	mA	
Quiescent Current Change	ΔI_B	1	$12.5V \leq V_{IN} \leq 29V$	-	-	1.0	mA	
Output Noise Voltage	V_{NO}	1	$T_a=25^{\circ}C$, $10Hz \leq f \leq 100kHz$ $I_{OUT}=50mA$	-	58	-	μV_{rms}	
Ripple Rejection Ratio	RR	1	$f=120Hz$, $13.5V \leq V_{IN} \leq 23.5V$, $I_{OUT}=50mA$, $T_j=25^{\circ}C$	55	71	-	dB	
Dropout Voltage	V_D	1	$I_{OUT}=1.0A$, $T_j=25^{\circ}C$	-	2.0	-	V	
Short Circuit Current Limit	I_{SC}	1	$T_j=25^{\circ}C$	-	250	-	mA	
Average Temperature Coefficient of Output Voltage	TC_{VO}	1	$I_{OUT}=5mA$, $0^{\circ}C \leq T_j \leq 125^{\circ}C$	-	-1	-	mV/ $^{\circ}C$	



FR7805P/D/DD ~ FR7824P/D/DD

FR7812P/D/DD

ELECTRICAL CHARACTERISTICS ($V_{IN}=19V$, $I_{OUT}=500mA$, $0^{\circ}C \leq T_j \leq 125^{\circ}C$)

CHARACTERISTIC	SYMBOL	TEST CIRCUIT	TEST CONDITION	MIN.	TYP.	MAX.	UNIT	
Output Voltage	V_{OUT}	1	$T_j=25^{\circ}C$, $I_{OUT}=100mA$	11.5	12.0	12.5	V	
			$14.5V \leq V_{IN} \leq 27V$ $5.0mA \leq I_{OUT} \leq 1.0A$, $P_o \leq 15W$	11.4	-	12.6		
Input Regulation	Reg line	1	$T_j=25^{\circ}C$	$14.5V \leq V_{IN} \leq 30V$	-	10	240	mV
				$16V \leq V_{IN} \leq 22V$	-	3	120	
Load Regulation	Reg load	1	$T_j=25^{\circ}C$	$5mA \leq I_{OUT} \leq 1.4A$	-	12	240	mV
				$250mA \leq I_{OUT} \leq 750mA$	-	4	120	
Quiescent Current	I_B	1	$T_j=25^{\circ}C$, $I_{OUT}=5mA$	-	5.1	8.0	mA	
Quiescent Current Change	ΔI_B	1	$14.5V \leq V_{IN} \leq 30V$	-	-	1.0	mA	
Output Noise Voltage	V_{NO}	1	$T_a=25^{\circ}C$, $10Hz \leq f \leq 100kHz$ $I_{OUT}=50mA$	-	76	-	μV_{rms}	
Ripple Rejection Ratio	RR	1	$f=120Hz$, $15V \leq V_{IN} \leq 25V$, $I_{OUT}=50mA$, $T_j=25^{\circ}C$	55	71	-	dB	
Dropout Voltage	V_D	1	$I_{OUT}=1.0A$, $T_j=25^{\circ}C$	-	2.0	-	V	
Short Circuit Current Limit	I_{SC}	1	$T_j=25^{\circ}C$	-	250	-	mA	
Average Temperature Coefficient of Output Voltage	TC_{VO}	1	$I_{OUT}=5mA$, $0^{\circ}C \leq T_j \leq 125^{\circ}C$	-	-1	-	mV/ $^{\circ}C$	



FR7805P/D/DD ~ FR7824P/D/DD

FR7815P/D/DD

ELECTRICAL CHARACTERISTICS ($V_{IN}=23V$, $I_{OUT}=500mA$, $0^{\circ}C \leq T_j \leq 125^{\circ}C$)

CHARACTERISTIC	SYMBOL	TEST CIRCUIT	TEST CONDITION	MIN.	TYP.	MAX.	UNIT	
Output Voltage	V_{OUT}	1	$T_j=25^{\circ}C$, $I_{OUT}=100mA$	14.4	15.0	15.6	V	
			$17.5V \leq V_{IN} \leq 30V$ $5.0mA \leq I_{OUT} \leq 1.0A$, $P_o \leq 15W$	14.25	-	15.75		
Input Regulation	Reg line	1	$T_j=25^{\circ}C$	$17.5V \leq V_{IN} \leq 30V$	-	11	300	mV
				$20V \leq V_{IN} \leq 26V$	-	3	150	
Load Regulation	Reg load	1	$T_j=25^{\circ}C$	$5mA \leq I_{OUT} \leq 1.4A$	-	12	300	mV
				$250mA \leq I_{OUT} \leq 750mA$	-	4	150	
Quiescent Current	I_B	1	$T_j=25^{\circ}C$, $I_{OUT}=5mA$	-	5.2	8.0	mA	
Quiescent Current Change	ΔI_B	1	$17.5V \leq V_{IN} \leq 30V$	-	-	1.0	mA	
Output Noise Voltage	V_{NO}	1	$T_a=25^{\circ}C$, $10Hz \leq f \leq 100kHz$ $I_{OUT}=50mA$	-	90	-	μV_{rms}	
Ripple Rejection Ratio	RR	1	$f=120Hz$, $18.5V \leq V_{IN} \leq 28.5V$, $I_{OUT}=50mA$, $T_j=25^{\circ}C$	54	70	-	dB	
Dropout Voltage	V_D	1	$I_{OUT}=1.0A$, $T_j=25^{\circ}C$	-	2.0	-	V	
Short Circuit Current Limit	I_{SC}	1	$T_j=25^{\circ}C$	-	250	-	mA	
Average Temperature Coefficient of Output Voltage	TC_{VO}	1	$I_{OUT}=5mA$, $0^{\circ}C \leq T_j \leq 125^{\circ}C$	-	-1	-	mV/ $^{\circ}C$	



FR7805P/D/DD ~ FR7824P/D/DD

FR7818P/D/DD

ELECTRICAL CHARACTERISTICS ($V_{IN}=27V$, $I_{OUT}=500mA$, $0^{\circ}C \leq T_j \leq 125^{\circ}C$)

CHARACTERISTIC	SYMBOL	TEST CIRCUIT	TEST CONDITION	MIN.	TYP.	MAX.	UNIT	
Output Voltage	V_{OUT}	1	$T_j=25^{\circ}C$, $I_{OUT}=100mA$	17.3	18.0	18.7	V	
			$21V \leq V_{IN} \leq 33V$ $5.0mA \leq I_{OUT} \leq 1.0A$, $P_o \leq 15W$	17.1	-	18.9		
Input Regulation	Reg line	1	$T_j=25^{\circ}C$	$21V \leq V_{IN} \leq 33V$	-	13	360	mV
				$24V \leq V_{IN} \leq 30V$	-	4	180	
Load Regulation	Reg load	1	$T_j=25^{\circ}C$	$5mA \leq I_{OUT} \leq 1.4A$	-	15	360	mV
				$250mA \leq I_{OUT} \leq 750mA$	-	5	180	
Quiescent Current	I_B	1	$T_j=25^{\circ}C$, $I_{OUT}=5mA$	-	5.2	8.0	mA	
Quiescent Current Change	ΔI_B	1	$21V \leq V_{IN} \leq 33V$	-	-	1.0	mA	
Output Noise Voltage	V_{NO}	1	$T_a=25^{\circ}C$, $10Hz \leq f \leq 100kHz$ $I_{OUT}=50mA$	-	110	-	μV_{rms}	
Ripple Rejection Ratio	RR	1	$f=120Hz$, $22V \leq V_{IN} \leq 32V$, $I_{OUT}=50mA$, $T_j=25^{\circ}C$	52	69	-	dB	
Dropout Voltage	V_D	1	$I_{OUT}=1.0A$, $T_j=25^{\circ}C$	-	2.0	-	V	
Short Circuit Current Limit	I_{SC}	1	$T_j=25^{\circ}C$	-	250	-	mA	
Average Temperature Coefficient of Output Voltage	TC_{VO}	1	$I_{OUT}=5mA$, $0^{\circ}C \leq T_j \leq 125^{\circ}C$	-	-1	-	mV/ $^{\circ}C$	



FR7805P/D/DD ~ FR7824P/D/DD

FR7824P/D/DD

ELECTRICAL CHARACTERISTICS ($V_{IN}=33V$, $I_{OUT}=500mA$, $0^{\circ}C \leq T_j \leq 125^{\circ}C$)

CHARACTERISTIC	SYMBOL	TEST CIRCUIT	TEST CONDITION	MIN.	TYP.	MAX.	UNIT	
Output Voltage	V_{OUT}	1	$T_j=25^{\circ}C$, $I_{OUT}=100mA$	23.0	24.0	25.0	V	
			$27V \leq V_{IN} \leq 38V$ $5.0mA \leq I_{OUT} \leq 1.0A$, $P_o \leq 15W$	22.8	-	25.2		
Input Regulation	Reg line	1	$T_j=25^{\circ}C$	$27V \leq V_{IN} \leq 38V$	-	18	480	mV
				$30V \leq V_{IN} \leq 36V$	-	6	240	
Load Regulation	Reg load	1	$T_j=25^{\circ}C$	$5mA \leq I_{OUT} \leq 1.4A$	-	15	480	mV
				$250mA \leq I_{OUT} \leq 750mA$	-	5	240	
Quiescent Current	I_B	1	$T_j=25^{\circ}C$, $I_{OUT}=5mA$	-	5.2	8.0	mA	
Quiescent Current Change	ΔI_B	1	$27V \leq V_{IN} \leq 38V$	-	-	1.0	mA	
Output Noise Voltage	V_{NO}	1	$T_a=25^{\circ}C$, $10Hz \leq f \leq 100kHz$ $I_{OUT}=50mA$	-	60	-	μV_{rms}	
Ripple Rejection Ratio	RR	1	$f=120Hz$, $28V \leq V_{IN} \leq 38V$, $I_{OUT}=50mA$, $T_j=25^{\circ}C$	50	67	-	dB	
Dropout Voltage	V_D	1	$I_{OUT}=1.0A$, $T_j=25^{\circ}C$	-	2.0	-	V	
Short Circuit Current Limit	I_{SC}	1	$T_j=25^{\circ}C$	-	230	-	mA	
Average Temperature Coefficient of Output Voltage	TC_{VO}	1	$I_{OUT}=5mA$, $0^{\circ}C \leq T_j \leq 125^{\circ}C$	-	-1.5	-	$mV/^{\circ}C$	

TEST CIRCUIT1/STANDARD APPLICATION CIRCUIT

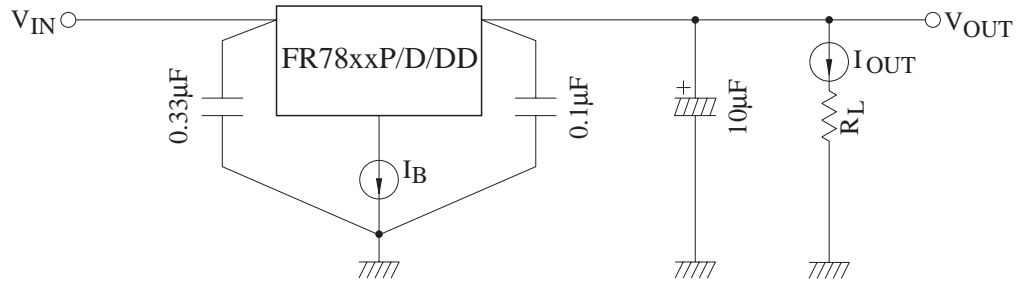

TEST CIRCUIT

1. V_{OUT} , $Reg \cdot line$, $Reg \cdot load$, V_{OUT} , I_B , ΔI_B , V_{NO} , $\Delta V_{OUT}/\Delta t$, $|V_{IN} - V_{OUT}|$, TC_{VO}

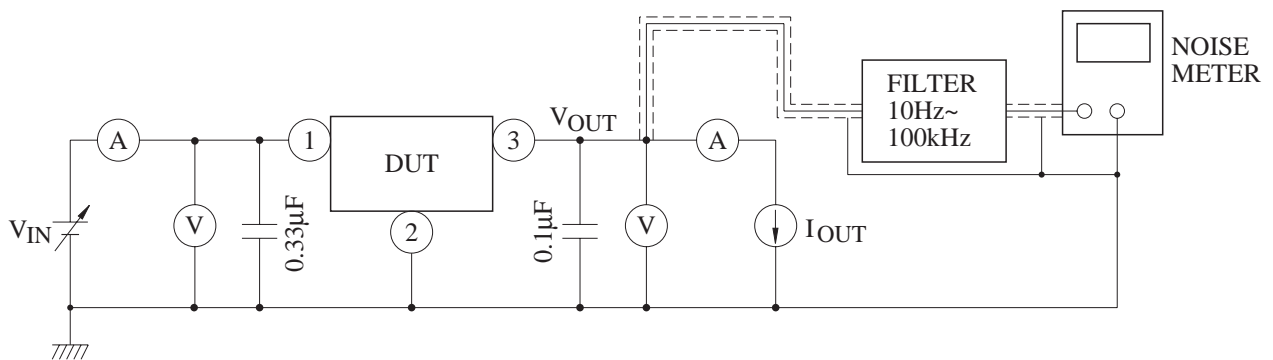

2. RR

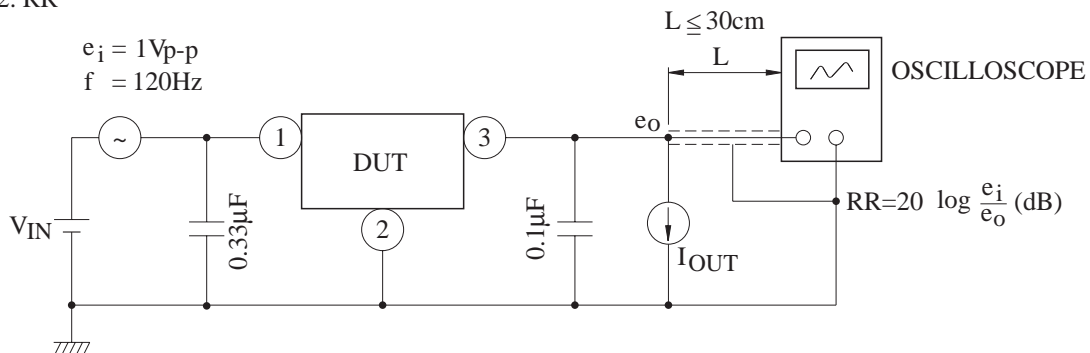



R7805P/D/DD ~ FR7824P/D/DD

