FR8008XP Datasheet

Bluetooth Low Energy SOC with SIG Mesh integrated

Version:v0.2

Release Date:2022.06

FreqChip Conf1



Content

Tables	3
Figures	4
Description.....	5
Features	5
Applications.....	5
Ordering Information.....	6
Product naming rules	6
1. Hardware Details.....	7
1.1 Block Diagram	7
1.2 Bluetooth Radio.....	8
1.3 Bluetooth Controller	8
1.4 Peripheral Interfaces	8
1.5 Integrated Power Control and Regulation	8
1.6 Battery Charger	9
2. Package and Pin Information.....	10
2.1 Package.....	10
2.2 Package Physical Dimensions	11
2.3 Pins Description	11
2.4 Application circuit	13
3. Electrical Characteristics.....	15
3.1 Absolute Maximum Ratings.....	15
3.2 Recommended Operating Conditions	15
3.3 Power Consumption.....	15
3.4 Crystal oscillator	16
Abbreviations	17
Contact Information	18
Revision History	18

Tables

Table 2-1 pin abbreviations.....	11
Table 2-2 pins description.....	11
Table 3-1 Absolute Maximum Ratings.....	15
Table 3-2 recommended operating conditions.....	15
Table 3-3 power consumption.....	15

FreqChip Confidential

Figures

Figure 1-1 Block Diagram	7
Figure 2-1 FR8008XP pins layout.....	10
Figure 2-2 FR8008AP pins layout	10
Figure 2-3 package physical dimensions	11
Figure 2-4 FR8008XP application circuit.....	13
Figure 2-5 FR8008AP application circuit	14

FreqChip Confidential

Description

FR8008XP is a family of SOC (system on chip) for rapid development of Bluetooth Low Energy related products. It contains Bluetooth V5.0 (LE Mode) fully compliant system with Freqchip designed firmware and software stack. Users can develop various applications based on embedded 32-bits high performance MCU.

With Freqchip's innovational technology, FR8008XP integrates, PMU (Li-battery charger + LDO), QSPI flash ROM with XIP mode, I2C, UART, GPIO, ADC, USB OTG, PWM all in a single chip, which provides customer with:

1. competitive power consumption
2. stable connection
3. low-cost BOM

The Bluetooth Smart firmware includes the L2CAP service layer protocols, Security Manager (SM), Attribute Protocol (ATT), the Generic Attribute Profile (GATT) and the Generic Access Profile (GAP). Furthermore, application profiles such as Proximity, Health Thermometer, Heart Rate, Blood Pressure, Glucose, Human Interface Device (HID) and SDK (include drivers, OS API, etc.) are supported. The SDK has integrated SIG Mesh for networking application.

Features

- Compliant with Bluetooth Specification V5.0 LE, support 2M, 1M, 500K and 125K data rate
- Embedded 32-bits Processor
 - up to 96Mhz speed
- Memory
 - Internal mask 128KB ROM
 - Up to 128Mb Flash ROM for user space software and data
 - 64KB SRAM + 2M PSRAM
- Integrated Battery Charger
- Integrated DC-DC Regulator
- Interface:
 - GPIO
 - UART
 - SPI/QSPI
 - I2C
 - PWM
 - USB OTG
- ROM Software:
 - bootloader
 - BLE Profile & Protocol: GATT, LM, LC, etc.
 - Driver API
 - SIG Mesh

Applications

- Smart Mouse
- Bluetooth Wearable
- SIG Mesh Application
- Smart Locks
- Domestic Appliances

Ordering Information

Part Number	Ambient temperature	Embedded Flash	Package	size
FR8008AP	-40°C ~ +85°C	4Mb	QFN40	5.0*5.0*0.9,0.4pitch
FR8008FP	-40°C ~ +85°C	32Mb	QFN40	5.0*5.0*0.9,0.4pitch
FR8008GP	-40°C ~ +85°C	64Mb	QFN40	5.0*5.0*0.9,0.4pitch
FR8008HP	-40°C ~ +85°C	128Mb	QFN40	5.0*5.0*0.9,0.4pitch

Product naming rules

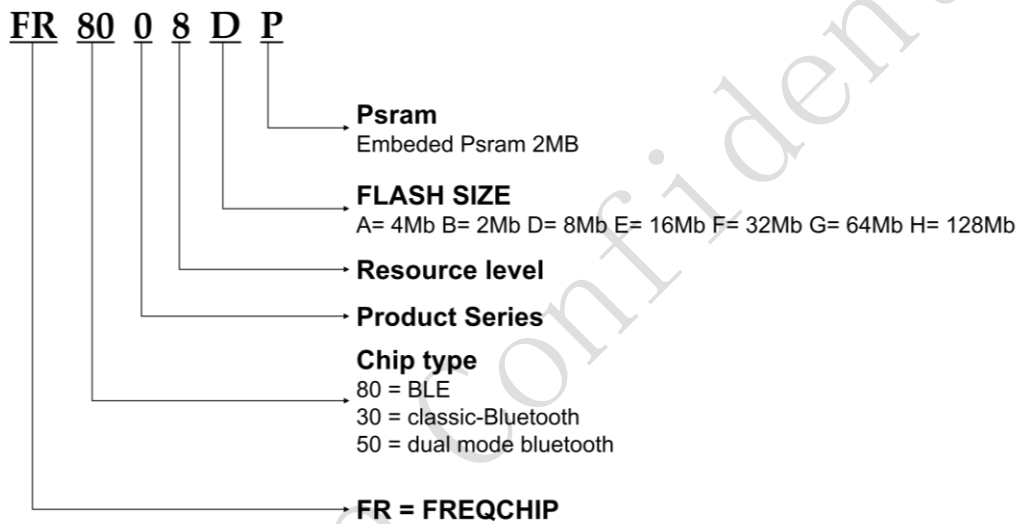

Product Series nomenclature

1. Hardware Details

1.1 Block Diagram

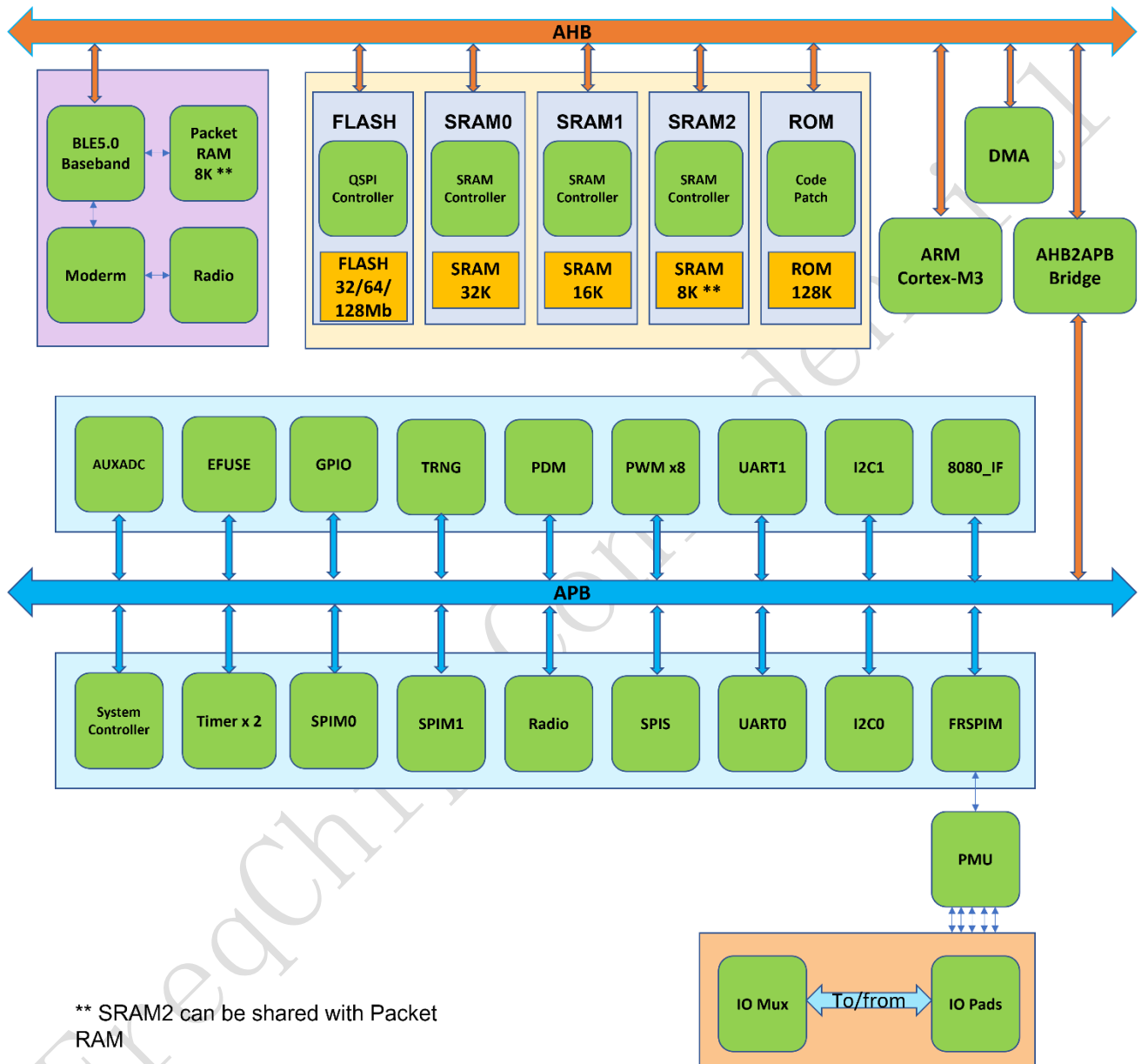

Figure 1-1 Block Diagram

1.2 Bluetooth Radio

- On-chip balun (50Ω impedance in TX and RX modes)
- No external trimming is required in production
- Qualified to Bluetooth v5.0 LE specification
- Up to 10dBm RF transmit power
- -98dBm (1M) receiver sensitivity in LDO mode
- Integrated channel filters
- Digital demodulator for improved sensitivity and co-channel rejection
- Real time digitized RSSI

1.3 Bluetooth Controller

- All device classes support (Broadcaster, Central, Observer, Peripheral)
- All packet types (Advertising / Data / Control)
- Encryption (AES / CCM)
- Bit stream processing (CRC, Whitening)
- Frequency hopping calculation
- Low power modes supporting internal 32.0 kHz RC oscillator
- Supports power down of the baseband during the protocol's idle periods

1.4 Peripheral Interfaces

- UART port for Debugging and AT Commands
- I2C interface to support external EEPROM or other devices (like G-SENSOR)
- Two channels QSPI interface, clock is up to 48Mhz
- Up to 28 general purpose IOs (28 IOs can be set in interrupt mode)
- General purpose 10-bits ADC used for ADKey and other analog input
- 8-channel PWM controller, with dead time control
- General purpose programmable timer for various task
- Watchdog used for tracking unexpected exception

1.5 Integrated Power Control and Regulation

- Embedded Power-On-Reset
- On-chip high efficiency switch-mode power supply, 1.8v to 4.3v input direct from battery and programmable output voltage
- On-chip Low Dropout (LDO) Linear Regulator for internal Digital, RF and Analog circuit
- Power management features include software shutdown and hardware wake-up
- Power-on-reset cell detects low supply voltage
- Internal voltage level detector

1.6 Battery Charger

- Lithium ion/Lithium polymer battery charger
- Embedded LVD(low voltage detect)
- Programmable charging current. Fast charging support up to 200mA with no external components

FreqChip Confidential

2. Package and Pin Information

2.1 Package

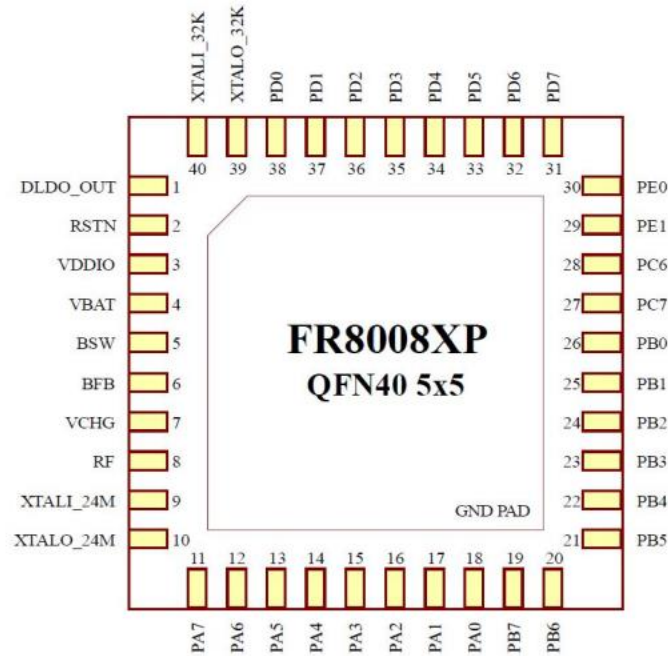

Figure 2-1 FR8008XP pins layout

Note:

Some pins of FR8008AP are slightly different from FR8008XP, Figure 2-2 shows FR8008AP pins layout

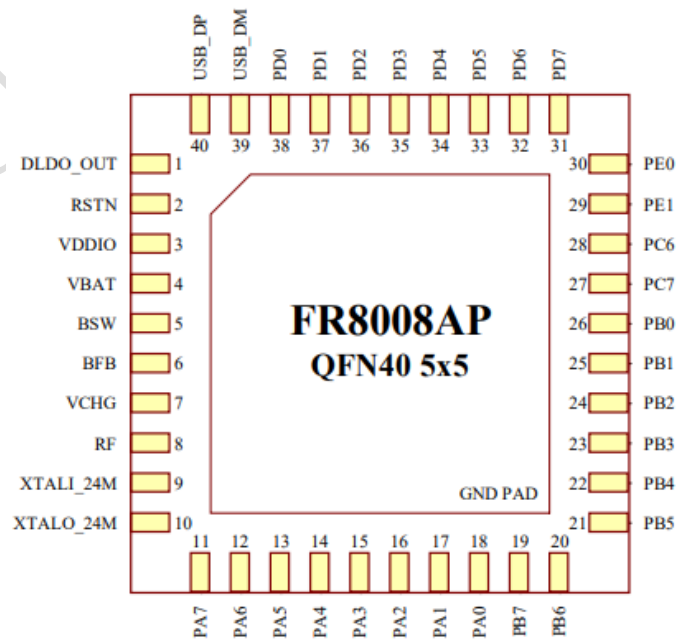

Figure 2-2 FR8008AP pins layout

2.2 Package Physical Dimensions

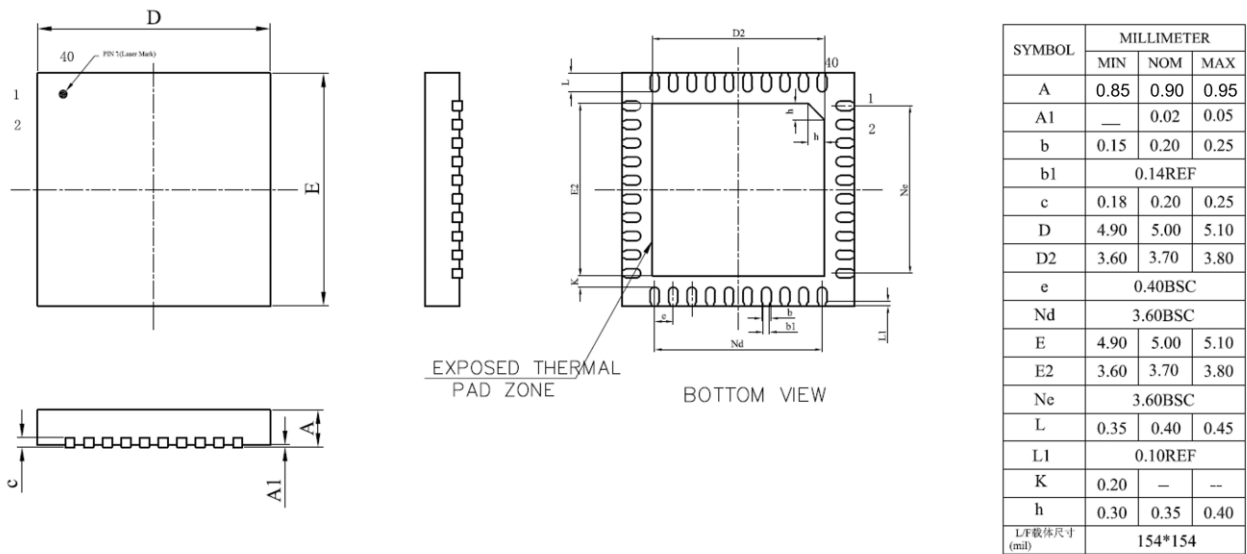

Figure 2-3 package physical dimensions

2.3 Pins Description

FR8008XP is a CMOS device. Floating level on input signals will cause unstable device operation and abnormal current consumption. Pull-up or Pull-down resistors should be used appropriately for input or bidirectional pins.

Table 2-1 pin abbreviations

Notation	Description
AI	Analog input
AO	Analog output
IO	Bidirectional(digital)
PWR	Power
GND	Ground

Table 2-2 pins description

Pin No.	Pin Name	Type	Description
1	DLDO_OUT	AO	Analog linear regulator output
2	RSTN	AI	Global reset (low active)
3	VDDIO	AO	Analog linear regulator output
4	VBAT	PWR	Battery positive supply input or charger output
5	BSW	AO	BUCK Switch output
6	BFB	AI	BUCK feedback input

Pin No.	Pin Name	Type	Description
7	VCHG	AI	Charger supply input
8	RF	AI/O	RF input and output
9	XTALI_24M	AO	24MHz Crystal oscillator input
10	XTALO_24M	AI	24MHz Crystal oscillator output
11	PA7	IO	Multi-function input/output digital IO
12	PA6	IO	Multi-function input/output digital IO
13	PA5	IO	Multi-function input/output digital IO
14	PA4	IO	Multi-function input/output digital IO
15	PA3	IO	Multi-function input/output digital IO
16	PA2	IO	Multi-function input/output digital IO
17	PA1	IO	Multi-function input/output digital IO
18	PA0	IO	Multi-function input/output digital IO
19	PB7	IO	Multi-function input/output digital IO
20	PB6	IO	Multi-function input/output digital IO
21	PB5	IO	Multi-function input/output digital IO
22	PB4	IO	Multi-function input/output digital IO
23	PB3	IO	Multi-function input/output digital IO
24	PB2	IO	Multi-function input/output digital IO
25	PB1	IO	Multi-function input/output digital IO
26	PB0	IO	Multi-function input/output digital IO
27	PC7	IO	Multi-function input/output digital IO
28	PC6	IO	Multi-function input/output digital IO
29	PE1	IO	Multi-function input/output digital IO
30	PE0	IO	Multi-function input/output digital IO
31	PD7	IO	Multi-function input/output digital IO
32	PD6	IO	Multi-function input/output digital IO
33	PD5	IO	Multi-function input/output digital IO
34	PD4	IO	Multi-function input/output digital IO
35	PD3	IO	Multi-function input/output digital IO
36	PD2	IO	Multi-function input/output digital IO
37	PD1	IO	Multi-function input/output digital IO
38	PD0	IO	Multi-function input/output digital IO
39	XTALO_32768(FR8008XP)	IO	32KHz Crystal oscillator output(FR8008XP)
	USB_DM(FR8008AP)		USB Data Minus(FR8008AP)
40	XTALI_32768(FR8008XP)	IO	32KHz Crystal oscillator input(FR8008XP)
	USB_DP(FR8008AP)		USB Data Positive(FR8008AP)

2.4 Application circuit

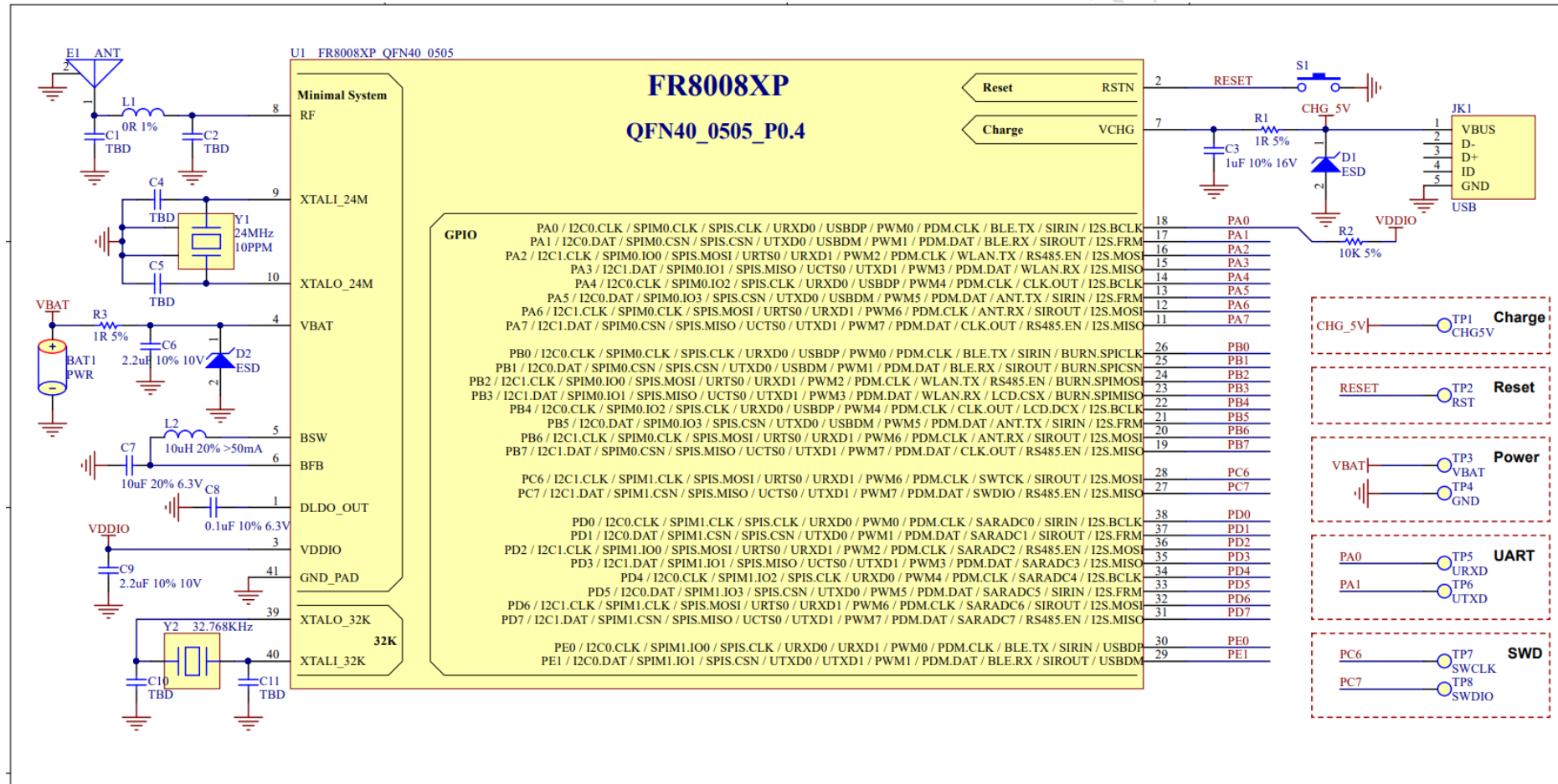

Figure 2-4 FR8008XP application circuit

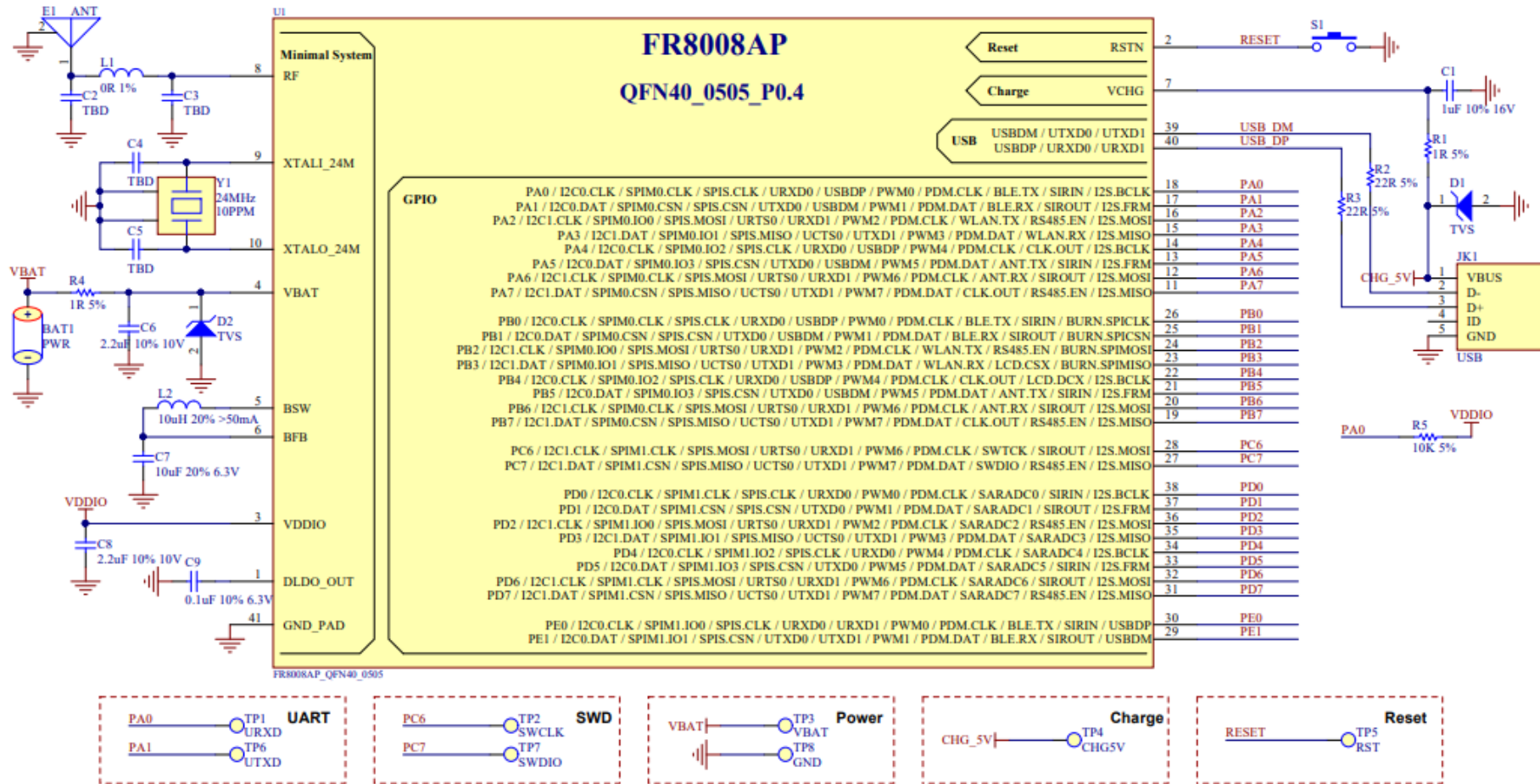

Figure 2-5 FR8008AP application circuit

3. Electrical Characteristics

3.1 Absolute Maximum Ratings

Continuous operation at or beyond these conditions may permanently damage the device.

Table 3-1 Absolute Maximum Ratings

Rating		Min	Max	Unit
Storage Temperature		-40	125	°C
Core Supply Voltage		0.9	1.2	V
I/O Voltage	VDDIO	1.6	3.3	V
Supply Voltage	VBAT	1.8	4.3	V
	VCHG	4.75	5.25	V

3.2 Recommended Operating Conditions

Table 3-2 recommended operating conditions

Operating Condition		Min	Typ	Max	Unit
Operating Temperature Range		-20	25	85	°C
Core Supply Voltage		0.9	1.1	1.2	V
I/O Voltage	VDDIO	1.6	2.9	3.3	V
Supply Voltage	VBAT	1.8	3.3	4.3	V
Charge input voltage	VCHG	4.75	5	5.25	V

VDDIO : Power-on default value is 1.8, user configurable later

3.3 Power Consumption

Table 3-3 power consumption

Operation Mode	Average	Max	Unit
TX peek current (0dB)		6.2	mA
RX peek current		6.5	mA
Deep sleep current (include 64K retention RAM)	<5		μA
Power off	<1		μA

3.4 Crystal oscillator

Clock Source	Min	Typ	Max	Unit
Main Crystal OSC(24MHz) for Bluetooth RF application				
Clock Frequency	24	24	24	MHz
Tolerance		+/-10		ppm

3.5 IO Resistor

Peripheral	Port Num	Mode	VDD	Value
GPIO	-	Pull-up	3.3V	8.1K
		Pull-down		6.5K
I2C	-	Pull-up	3.3V	3K
		Pull-down		6.5K
USB	-	Pull-up	3.3V	1.5K
		Pull-down		15K

3.6 ESD

Pin name	Human body model(HBM)	Charged-device model(CDM)
RF	±2000V	±200V
XTALI	±2000V	±500V
XTALO	±2000V	±500V
OTHERS	±2000V	±2000V

Abbreviations

Abbreviations	Descriptions
AEC	acoustic echo cancellers
AGC	Automatic Gain Control
ANS	Automatic Noise Suppression
ADC	Analog-to-Digital-Converter
DAC	Digital-to-Analog-Converter
GPIO	General Purpose Input Output
MIC	Microphone
PMU	Power Management Unit
OSC	Oscillator
PA	Power Amplifier
SoC	system on chip

Contact Information

Website: www.freqchip.com

Sales Email: sales@freqchip.com

Phone: +86-21-5027-0080

Revision History

Feedback:

Freqchip welcomes feedback on this product and this document. If you have comments or suggestions, please send an email to docs@freqchip.com.

Reversion Number	Reversion Date	Description
V0.1	2022.03.07	Initial Draft
V0.2	2002.06.10	Add IO Resistor and ESD Information