

23V, 1.8A, 1.4MHz Asynchronous Step-Down DC/DC Converter

Description

The FR9702 is a monolithic step-down switch mode converter with a built-in power MOSFET. It achieves 1.8A output current over a wide input supply range with excellent load and line regulation. Current mode operation provides fast transient response and eases loop stabilization. Fault condition protection includes cycle-by-cycle current limiting and over temperature protection.

The FR9702 requires a minimum number of available standard external components. The FR9702 is available in TSOT23-6 and SOT23-6 packages.

Pin Assignment

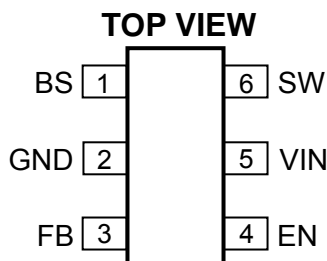

Features

- 1.8A Output Current
- 180mΩ Internal Power MOSFET Switch
- Stable with Low ESR Output Ceramic Capacitors
- Up to 92% Efficiency
- Fixed 1.4MHz Frequency
- Current Mode Operation
- Over-Temperature Protection with Hiccup-Mode
- Cycle-by-Cycle Over Current Protection
- Wide 4.5V to 23V Operating Input Range
- Output Adjustable from 0.805V to 15V
- 10uA Shutdown Current
- Available in TSOT23-6 and SOT23-6 Packages

Applications

- Distributed Power Systems
- Battery Charger
- OLPC, Netbook
- Pre-Regulator for Linear Regulators
- WLED Drivers

Ordering Information

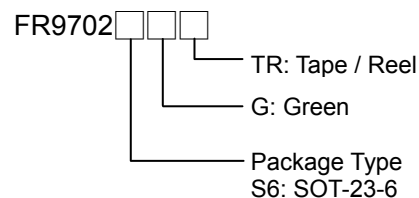

Absolute Maximum Ratings (Note 1)

Supply Voltage V_{IN}	26V
V_{SW}	-0.3V to $V_{IN} + 0.3V$
V_{BS}	$V_{sw} + 6V$
All Other Pins.....	-0.3V to +6V
Junction Temperature.....	150°C
Lead Temperature	260°C
Storage Temperature	-65°C to +150°C

Recommended Operating Conditions (Note 2)

Input Supply Voltage V_{IN}	4.5V ~ 23V
Output Voltage V_{OUT}	0.805V ~ 15V
Ambient Temperature T_A	-40°C ~ 85°C

Thermal Characteristics

TSOT23-6 θ_{JA}	220°C /W
TSOT23-6 θ_{JC}	110°C /W
SOT23-6 θ_{JA}	220°C /W
SOT23-6 θ_{JC}	110°C /W

Note 1: Stresses exceed those ratings may damage the device.

Note 2: If out of its operation conditions, the device is not guaranteed to function.

Electrical Characteristic

($V_{IN} = 12V$, $T_A = 25^\circ C$, unless otherwise specified)

Parameter	Test Conditions	Min	Typ	Max	Unit
Feedback Voltage	$4.5V \leq V_{IN} \leq 23V$	0.785	0.805	0.825	V
Switch-On Resistance (*)			180		mΩ
Switch Leakage	$V_{EN} = 0V$, $V_{SW} = 0V$			10	μA
Current Limit (*)			3		A
Oscillator Frequency		1.2	1.4	1.7	MHz
Fold-back Frequency	$V_{FB} = 0V$		460		KHz
Maximum Duty Cycle			85		%
Minimum On-Time (*)			100		ns

Electrical Characteristic (continued)

($V_{IN} = 12V$, $T_A = 25^{\circ}C$, unless otherwise specified)

Parameter	Test Conditions	Min	Typ	Max	Unit
Under Voltage Lockout Threshold Rising		4.1	4.4	4.7	V
Under Voltage Lockout Threshold Hysteresis			250		mV
EN Input Low Voltage				0.4	V
EN Input High Voltage		1.2			V
EN Input Current	$V_{EN} = 2V$		2.0		μA
	$V_{EN} = 0V$		0.1		
Supply Current (Shutdown)	$V_{EN} = 0V$		10		μA
Supply Current (Quiescent)	$V_{EN} = 2V$, $V_{FB} = 1V$		1.8		mA
Over-Temperature Protection Threshold (*)			150		$^{\circ}C$

*: Guaranteed by design

Block Diagram

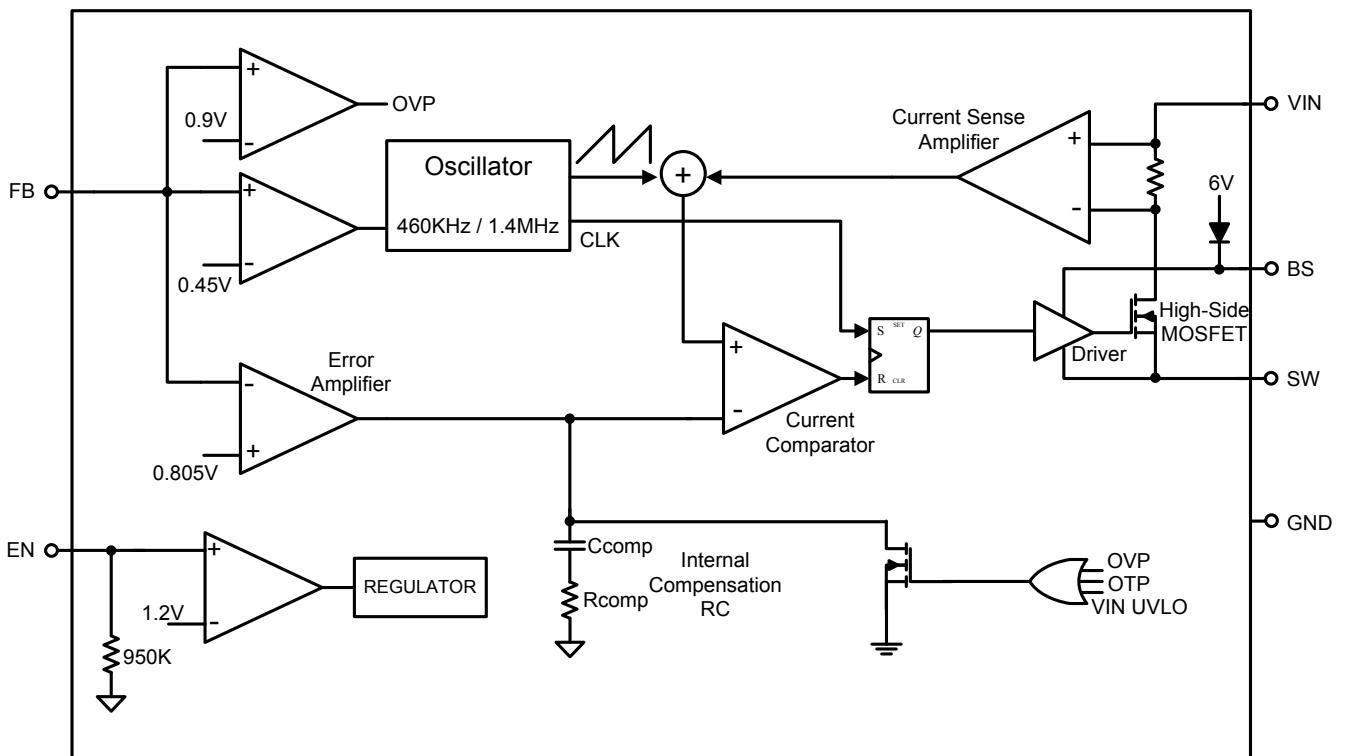

Figure 1 FR9702 Functional Block Diagram

Function Pin Description

Pin NO.	Pin Name	Pin Description
1	BS	Bootstrap. A 22nF capacitor is connected between SW and BS pins to drive the power switch's gate above the supply voltage.
2	GND	Ground. This pin is the voltage reference for the regulated output voltage. For this reason care must be taken in its layout.
3	FB	Feedback. An external resistor divider from the output to GND, tapped to the FB pin sets the output voltage.
4	EN	On/Off Control Input. Pull EN above 1.2V and below 5V to turn the device on.
5	VIN	Power Supply Input. Drive 4.5V to 23V voltage to this pin to power on this chip. Connecting a 10uF ceramic bypass capacitor between VIN and GND to eliminate noise.
6	SW	Switch Output. Connect this pin to the switching end of the inductor.

Typical Application Circuit

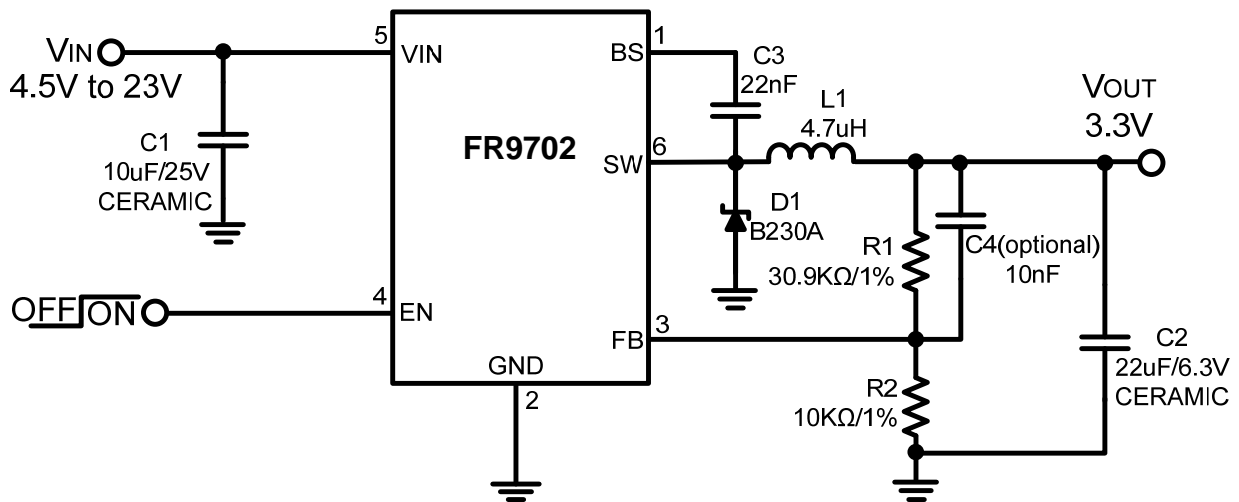
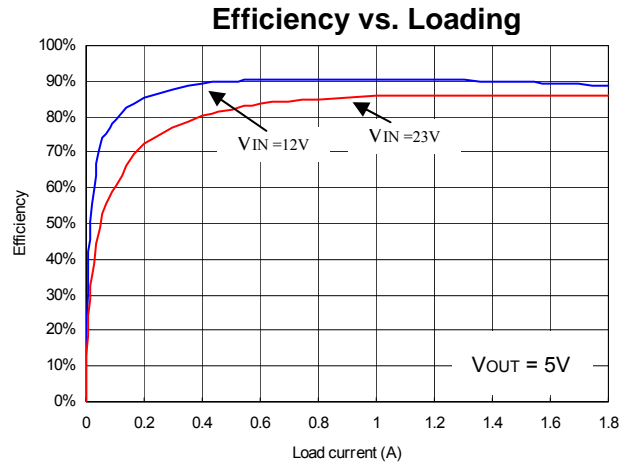
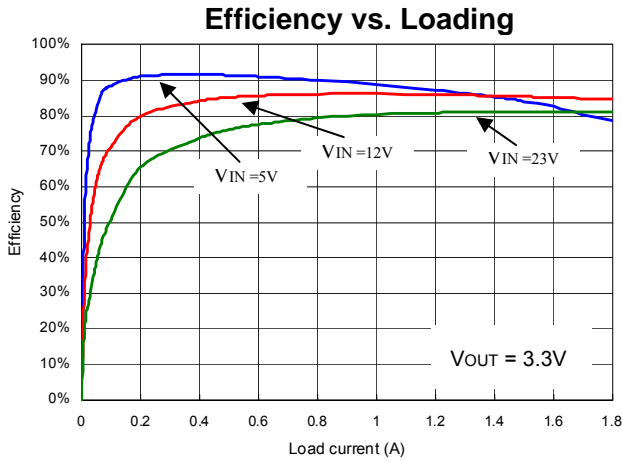

Figure 2 Output 3.3V Application Circuit

Typical Operating Characteristics

$V_{IN} = 12V$, $V_{OUT} = 3.3V$, $C1 = 10\mu F$, $C2 = 22\mu F$, $L1 = 4.7\mu H$, $T_A = +25^\circ C$, unless otherwise noted.



Feedback Voltage vs. Case Temperature

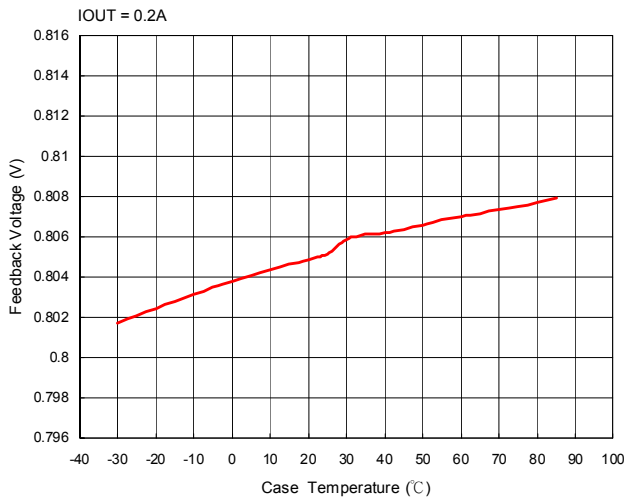

Switching Frequency vs. Case Temperature

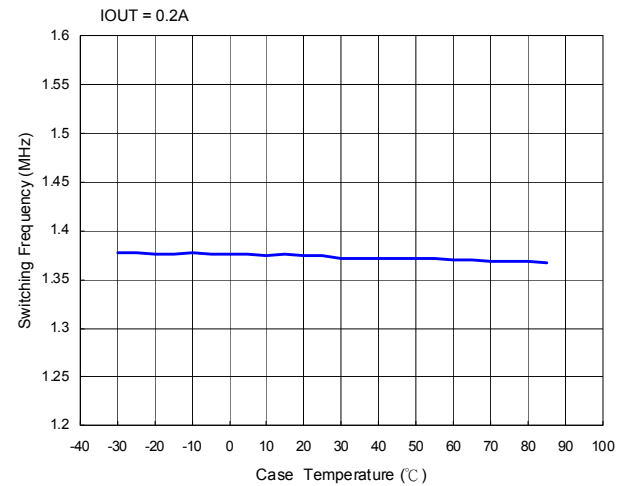

DC Ripple Waveform

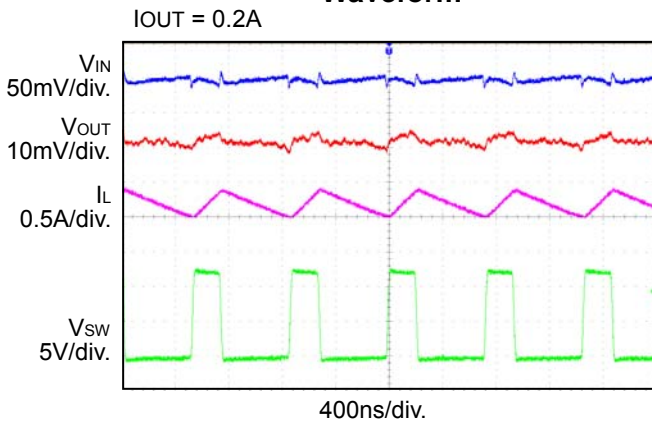

DC Ripple Waveform

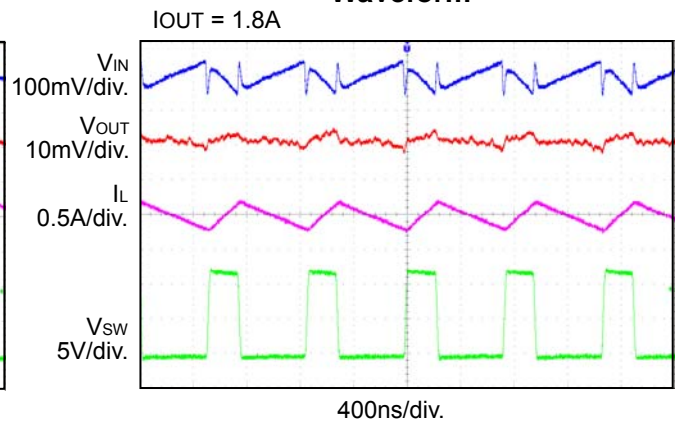

Typical Operating Characteristics (continued)

$V_{IN} = 12V$, $V_{OUT} = 3.3V$, $C1 = 10\mu F$, $C2 = 22\mu F$, $L1 = 4.7\mu H$, $T_A = +25^\circ C$, unless otherwise noted.

Startup Through Enable Waveform

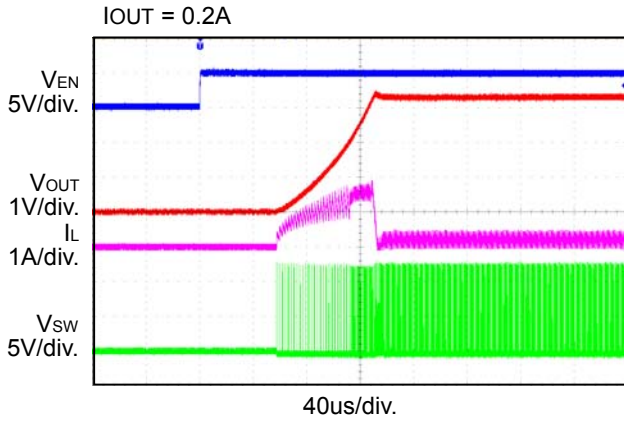

Startup Through Enable Waveform

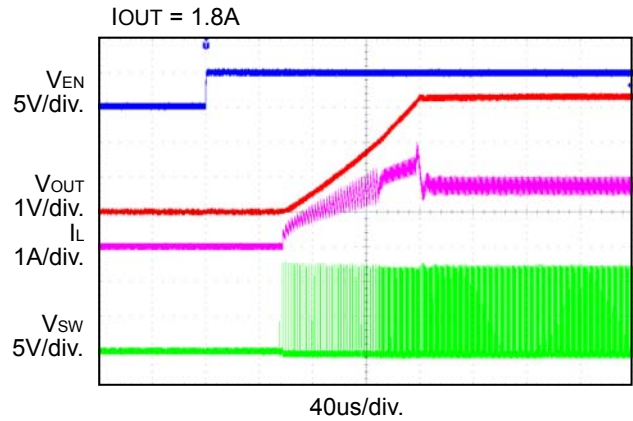

Shutdown Through Enable Waveform

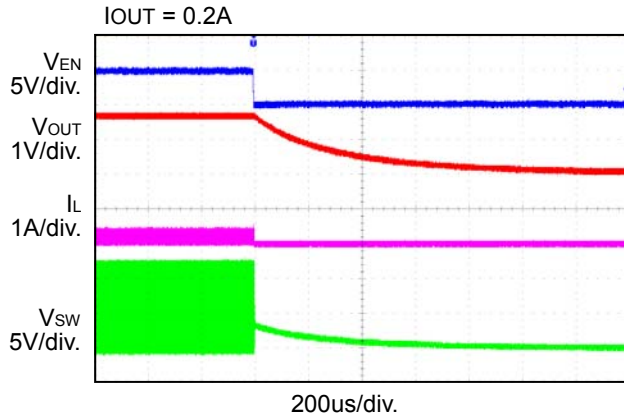

Shutdown Through Enable Waveform

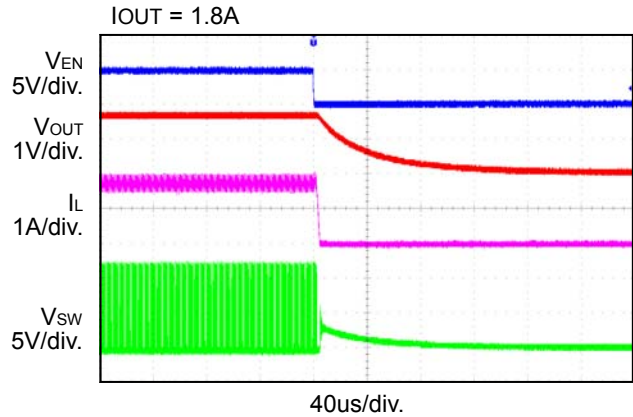

Load Transient Waveform

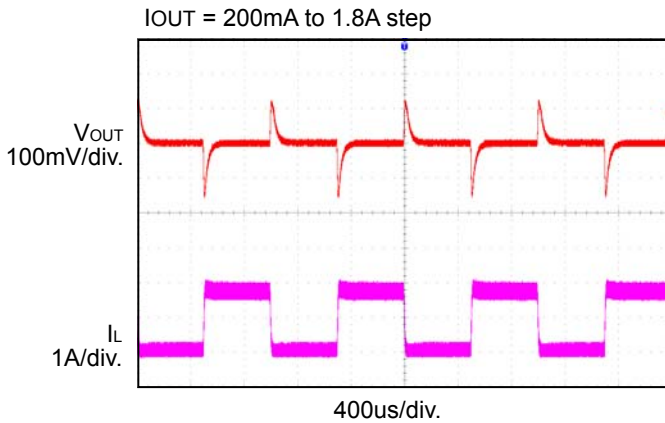

Short Circuit Test Waveform

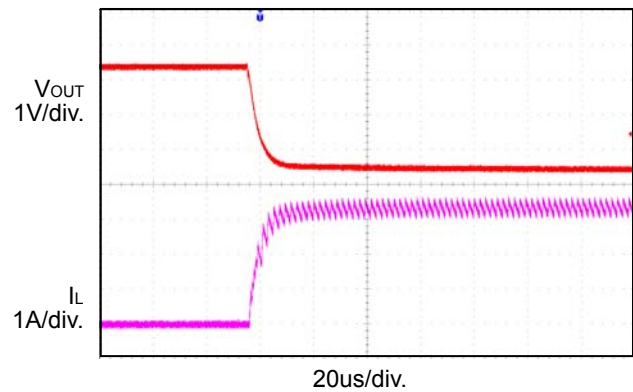

Application Information

Setting EN Automatic Startup Voltage

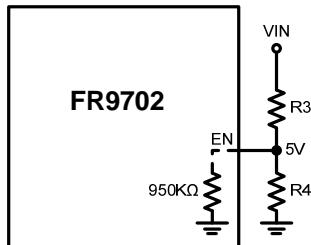

The external resistor divider is used to set the EN automatic startup voltage:

$$R4 = \frac{V_{EN}}{\left(\frac{V_{IN}-V_{EN}}{R3}\right)}$$

For example, $V_{IN} = 12V$, $R3 = 100K\Omega$, thus $R4$ resistor value is:

$$R4 = \frac{5V}{\left(\frac{12V-5V}{100K\Omega}\right)} \approx 71.5K\Omega$$

Table 1 shows a list of resistor selection for common input voltages:

Table 1—Resistor Selection for Common Input Voltages

V_{IN}	R3	R4
5V	100K Ω	NC
12V	100K Ω	71.5K Ω
16V	100K Ω	45.3K Ω

Setting Output Voltage

The external resistor divider is used to set the output voltage. FR9702 feedback resistors are unconcerned of compensation and provide an easy way to program output voltage. Table 2 shows a list of resistor selection for common output voltages:

$$V_{OUT} = 0.805 \times \left(1 + \frac{R1}{R2}\right) V$$

Table 2—Resistor Selection for Common Output Voltages

V_{OUT}	R1	R2
5V	43K Ω	8.2K Ω
3.3V	30.9K Ω	10K Ω
2.5V	21K Ω	10K Ω
1.8V	12.4K Ω	10K Ω
1.2V	4.99K Ω	10K Ω

Selecting the Inductor

A 4.7 μ H inductor with a DC current rating of at least 25% percent higher than the maximum load current is recommended for most applications. For highest efficiency, the inductor's DC resistance should be less than 200m Ω . For most designs, the required inductance value can be derived from the following equation.

$$\Delta I = 0.3 \times I_{L(MAX)}$$

$$L \geq (V_{IN}-V_{OUT}) \times \left(\frac{V_{OUT}}{F_{SW} \times \Delta I \times V_{IN}}\right)$$

Where ΔI is the inductor ripple current.

Choose the inductor ripple current to be 30% of the maximum load current. The maximum inductor peak current is calculated from:

$$I_{L(MAX)} = I_{LOAD} + \frac{\Delta I_L}{2}$$

Under light load conditions below 100mA, a larger inductance is recommended for improved efficiency.

Selecting the Input Capacitor

The input capacitor reduces the surge current drawn from the input supply and the switching noise from the device. The input capacitor impedance at the switching frequency should be less than the input source impedance to prevent

high frequency switching current from passing through the input. Ceramic capacitors with X5R or X7R dielectrics are highly recommended because of their low ESR and small temperature coefficients. For most applications, a 10 μ F capacitor is sufficient.

Selecting the Output Capacitor

The output capacitor keeps the output voltage ripple small and a 22 μ F ceramic capacitor with X5R or X7R dielectrics is recommended for its low ESR characteristics.

External Bootstrap Diode

An external bootstrap diode is recommended if the input voltage is less than 5V or if there is a 5V system rail available. This diode helps improve the efficiency. Low cost diodes, such as 1N4148 are suitable for this application.

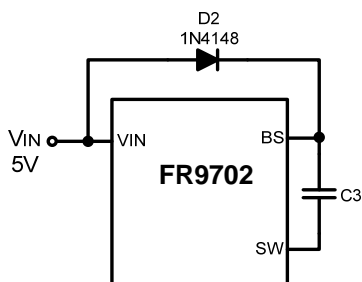

recommended to follow these general guidelines show below:

1. Place the input capacitors, output capacitors as close to the device as possible. Trace to these capacitors should be as short and wide as possible to minimize parasitic inductance and resistance.
2. Place VIN bypass capacitors close to the VIN pin.
3. Place feedback resistors close to the FB pin.
4. Keep the sensitive signal FB away from the switching signal SW.

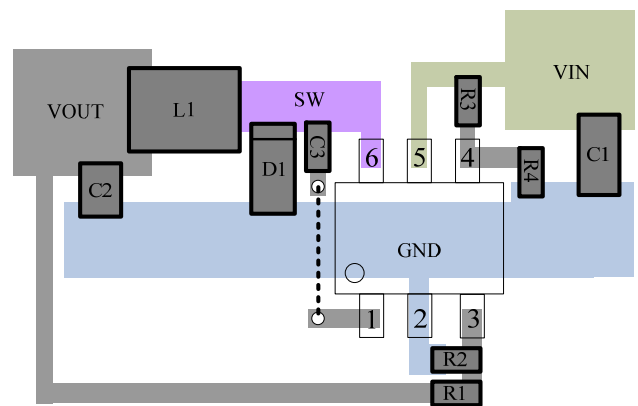

Figure 3 Recommended Layout Diagram

Rectifier Diode

Use a Schottky diode as the rectifier to conduct current when the high-side power MOSFET is off. The Schottky diode must have current rating higher than the maximum output current and the reverse voltage rating higher than the maximum input voltage.

PCB Layout Recommendation

The device’s performance and stability is dramatically affected by PCB layout. It is

Package Information

SOT23-6

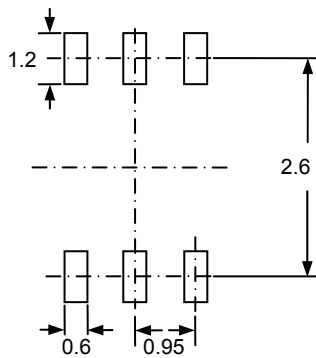
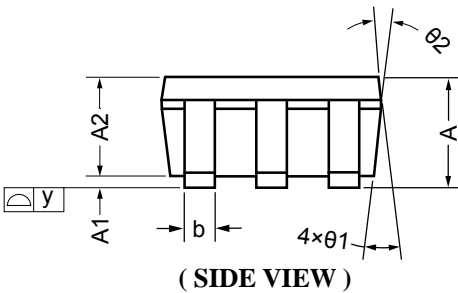
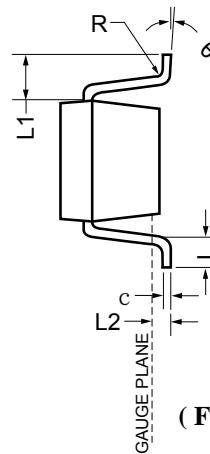
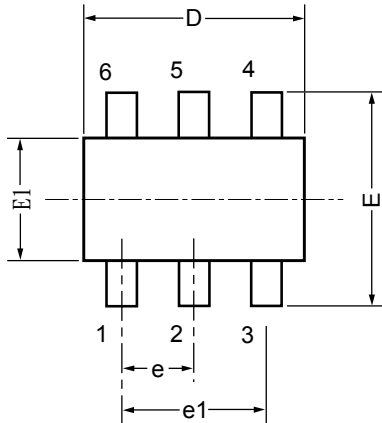

UNIT: MM

SYMBOLS	MIN	NOM	MAX
A	1.05	----	1.35
A1	0.05	----	0.15
A2	1.00	1.10	1.20
b	0.30	----	0.50
c	0.08	----	0.20
D	2.80	2.90	3.00
E	2.60	2.80	3.00
E1	1.50	1.60	1.70
e	0.95 BSC		
e1	1.90 BSC		
L	0.35	0.45	0.55
L1	0.60 REF		
L2	0.25 BSC		
y	----	----	0.10
R	0.10	----	----
theta	0°	----	8°
theta1	7° NOM		
theta2	5° NOM		

NOTES:

1. JEDEC OUTLINE: MO-178C
2. DIMENSION "D" DOES NOT INCLUDE MOLD FLASH, PROTRUSIONS OR GATE BURRS. MOLD FLASH, PROTRUSIONS OR GATE BURRS SHALL NOT EXCEED .10mm PER SIDE.
3. DIMENSION "E1" DOES NOT INCLUDE INTER-LEAD FLASH, OR PROTRUSIONS. INTER-LEAD FLASH OR PROTRUSIONS SHALL NOT EXCEED .15mm PER SIDE

Carrier Tape & Reel Dimensions

SOT23-6

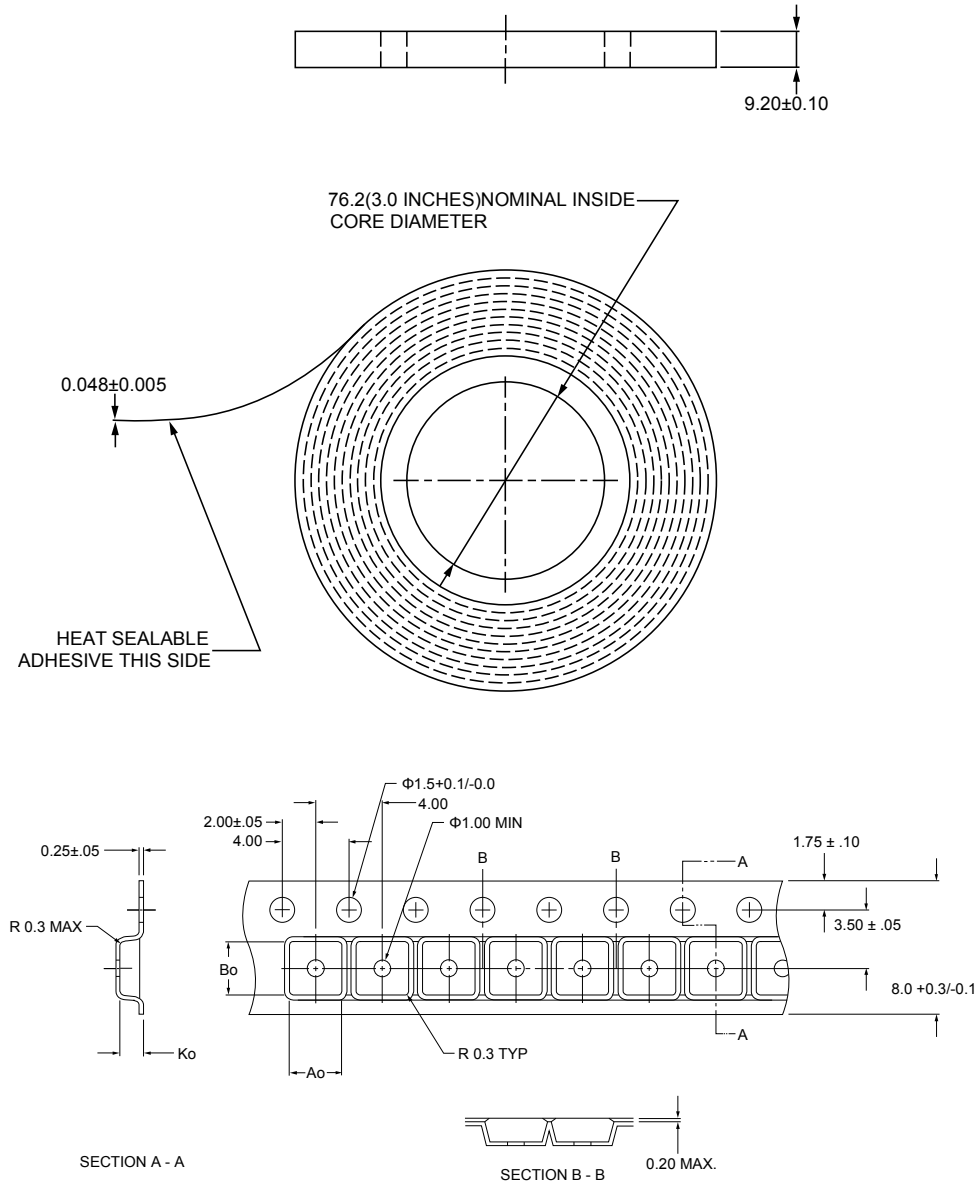

Ao = 3.15
 Bo = 3.20
 Ko = 1.40 +0.10/-0

NOTES:

1. DIM IN MM.
2. 10 SPROCKET HOLE PITCH CUMULATIVE TOLERANCE ±0.2.
3. POCKET POSITION RELATIVE TO SPROCKET HOLE MEASURED AS TRUE POSITION OF POCKET, NOT POCKET HOLE.

Life Support Policy

Fitipower's products are not authorized for use as critical components in life support devices or other medical systems.