

24V, 1.5A, 1.2MHz LED Driver with Dimming Control

Description

The FR9703 is a current mode, control LED driver IC. It provides wide 2.8V to 24V input voltage range and 1.5A output current capability.

The FR9703 includes a PWM dimming input that can accept an external control signal with a duty ratio of 5% to 100% and PWM dimming is from 500Hz to 1MHz. PWM dimming frequency below 500Hz and external control signal with a duty ratio of 1% to 100%.

It also supports 0.65V to 1.2V analog dimming input which can be used for linear dimming of the LED current.

The FR9703 fault protection includes current limit, input OVP, UVLO and thermal shutdown. The soft-start function prevents inrush current at turn-on. Internal compensation function reduces external compensatory components and simplifies the design process.

Features

- Input Voltage Range: 2.8V to 24V
- 1.5A Output Current
- 1.2MHz Switching Frequency
- 200mQ Integrated Power MOSFET
- 100mV Reference Voltage
- Analog and PWM Dimming Techniques
- Cycle-by-Cycle Current Limit
- Over-Temperature Protection with Auto Recovery
- Input Under Voltage Lockout
- Input Over Voltage Protection
- SOT-23-6 Package

Applications

- LED Driver
- IP Camera
- LED Flashlights

Pin Assignments

S6 Package (SOT-23-6)

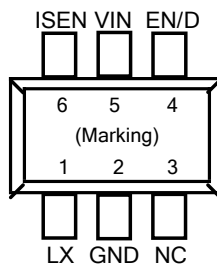

Figure 1. Pin Assignments of FR9703

Ordering Information

FR9703 Package Type
S6: SOT-23-6 Package

SOT-23-6 Marking

Part Number	Product Code
FR9703S6	FU2

Typical Application Circuit

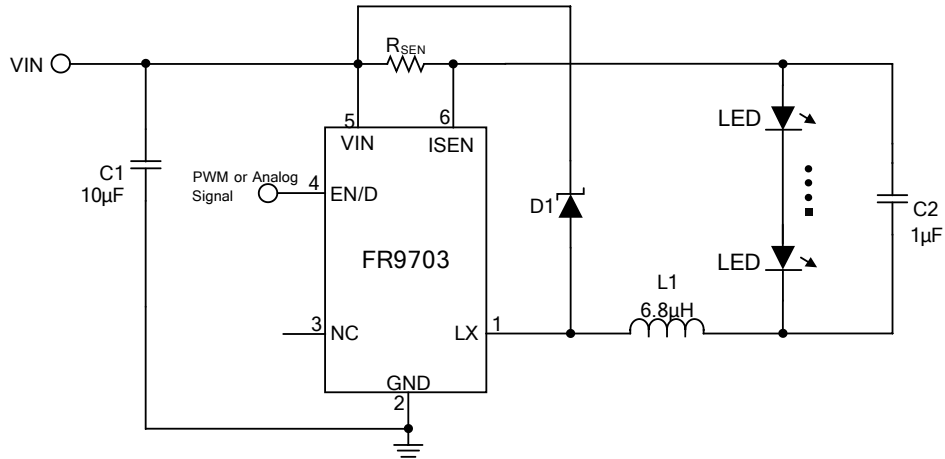

Figure 2. Buck Application Circuit

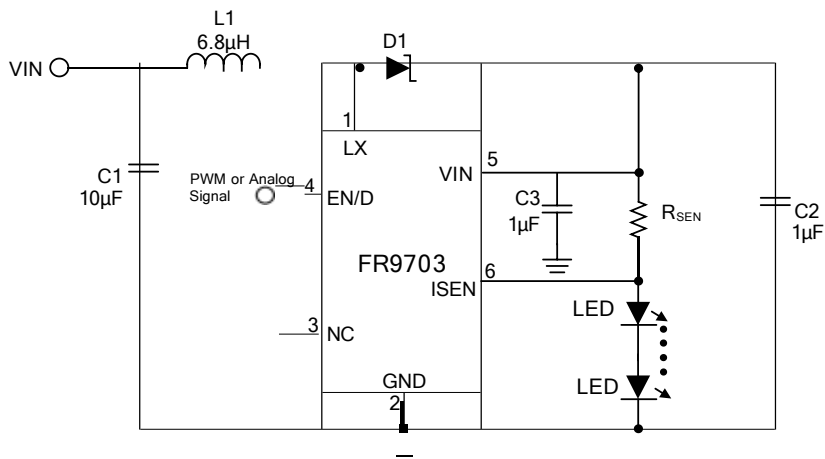

Figure 3. Boost Application Circuit

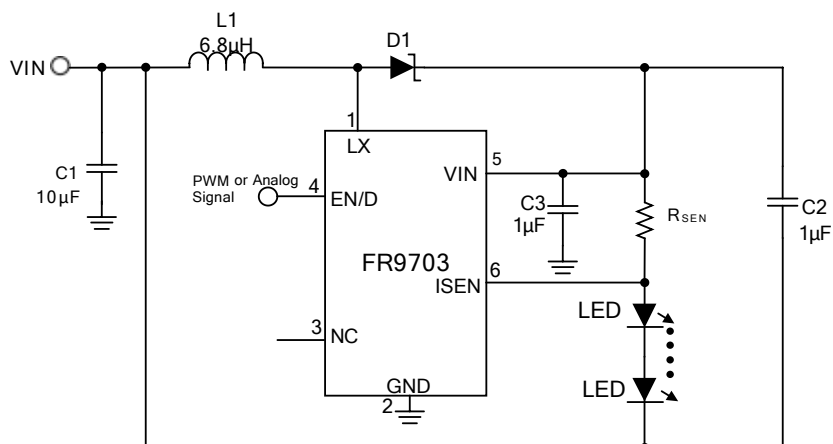

Figure 4. Buck-Boost Application Circuit

Note 1: LED dimming control can be done from either analog or PWM signal at the EN/D pin.

Functional Pin Description

Pin Name	Pin No.	Pin Function
LX	1	Power switching node. Connect an external inductor to this switching node.
GND	2	Ground pin.
NC	3	No connection. Keeps this pin floating.
EN/D	4	Enable control input and dimming control input . Logic high enables operation. This pin can select Analog or PWM dimming controls the brightness of LEDs .
VIN	5	Power supply input pin. Placed input capacitors as close as possible from VIN to GND to avoid noise influence.
ISEN	6	Current sense input pin. Connect an external resistor from VIN to ISEN to set the LED Current.

Block Diagram

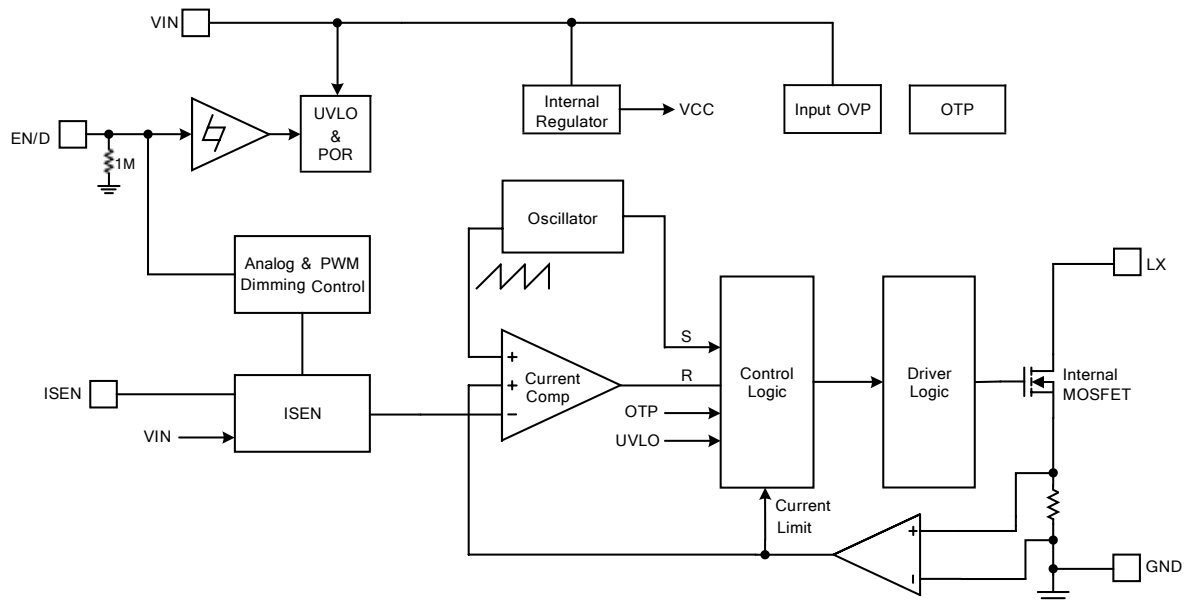

Figure 5. Block Diagram of FR9703

Absolute Maximum Ratings ^(Note 2)

- Supply Voltage V_{IN} ----- -0.3V to +28V
- Enable Voltage $V_{EN/D}$ ----- -0.3V to +28V
- ISEN V_{ISEN} ----- -0.3V to +28V
- LX Voltage V_{LX} ----- -0.3V to $V_{IN} + 0.3V$
- All Other Pins Voltage ----- -0.3V to +6V
- Maximum Junction Temperature (T_J) ----- +150°C
- Storage Temperature (T_S) ----- 65°C to +150°C
- Lead Temperature (Soldering, 10sec.) ----- +260°C
- Package Thermal Resistance, (θ_{JA}) ^(Note 3)
 - SOT-23-6 ----- 250°C/W
- Package Thermal Resistance, (θ_{JC})
 - SOT-23-6 ----- 110°C/W

Note 2: Stresses beyond this listed under “Absolute Maximum Ratings” may cause permanent damage to the device.

Note 3: θ_{JA} is measured at 25°C ambient with the component mounted on a high effective thermal conductivity 4-layer board of JEDEC-51-7. The thermal resistance greatly varies with layout, copper thickness, number of layers and PCB size.

Recommended Operating Conditions

- Supply Voltage V_{IN} ----- +2.8V to +24V
- Operation Temperature Range ----- -40°C to +85°C

Electrical Characteristics

($V_{IN}=12V$, $T_A=25^{\circ}C$, unless otherwise specified.)

Parameter	Symbol	Conditions	Min	Typ	Max	Unit
V_{IN} Quiescent Current	I_{DDQ}	$V_{END}=1.2V$, $V_{ISEN}=0.3V$		100	200	pA
V_{IN} Shutdown Supply Current	I_{SD}	$V_{END}=0V$			10	pA
Reference Voltage	V_{REF}		96	100	104	mV
MOSFET $R_{DS(ON)}$	$R_{DS(ON)}$			200		mQ
MOSFET Leakage Current	$I_{LX(leak)}$	$V_{END}=1.2V$, $V_{LX}=24V$			10	pA
LX Current Limit	I_{LIMIT}		1.7			A
Oscillation Frequency	F_{OSC}			1.2		MHz
Maximum Duty Cycle	D_{MAX}			100		%
Minimum On Time ^(Note 4)	T_{MIN}			100		ns
Input Supply Voltage UVLO Threshold	$V_{UVLO(Vth)}$	V_{IN} Rising		2.5		V
Input Supply Voltage UVLO Threshold Hysteresis	$V_{UVLO(HYS)}$			200		mV
EN/D High-Level Input Voltage	V_{END}	V_{END} Rising	0.65			V
EN/D Low-Level Input Voltage	V_{END}	V_{END} Falling			0.3	V
Analog Dimming Range	V_{END}		0.65		1.2	V
Analog Dimming Scale		$V_{END} = 0.65V$		5		%
Analog Dimming Scale		$V_{END} = 1.2V$		100		%
Input Over Voltage Protection	V_{IN_OVP}			26.7		V
Thermal Shutdown Temperature ^(Note 4)	T_{SD}			150		$^{\circ}C$
Thermal Shutdown Hysteresis ^(Note 4)	T_{HYS}			20		$^{\circ}C$

Note 4: Not production tested.

Typical Performance Curves

$V_{IN}=12V, I_{OUT}=1.0A, 1S2P LED$

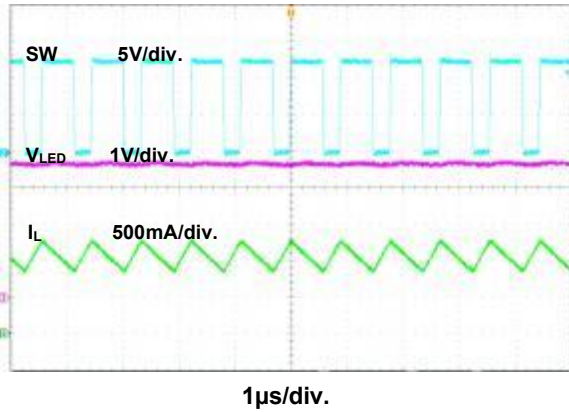

Figure 6. Switching Waveform

$V_{IN}=15V, I_{OUT}=1.0A, 2S2P LED$

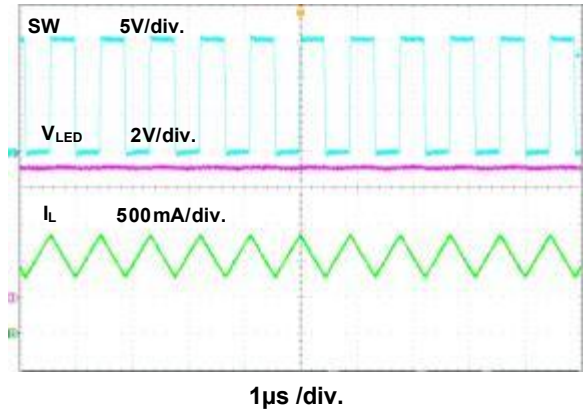

Figure 7. Switching Waveform

$V_{IN}=24V, I_{OUT}=1.0A, 5S2P LED$

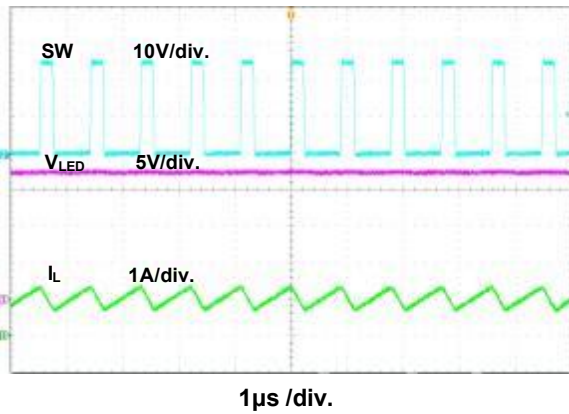

Figure 8. Switching Waveform

$V_{IN}=12V, I_{OUT}=1.0A, 1S2P LED$

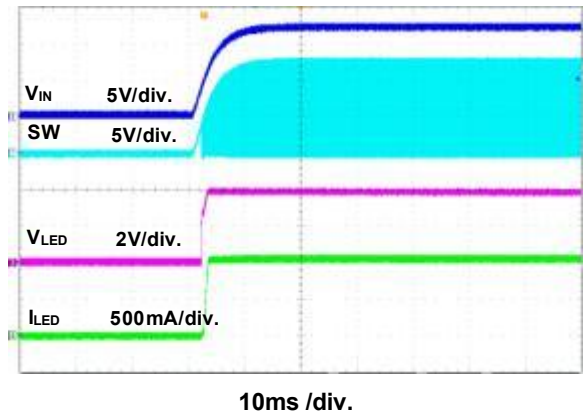

Figure 9. Power On through V_{IN} Waveform

$V_{IN}=12V, I_{OUT}=1.0A, 1S2P LED$

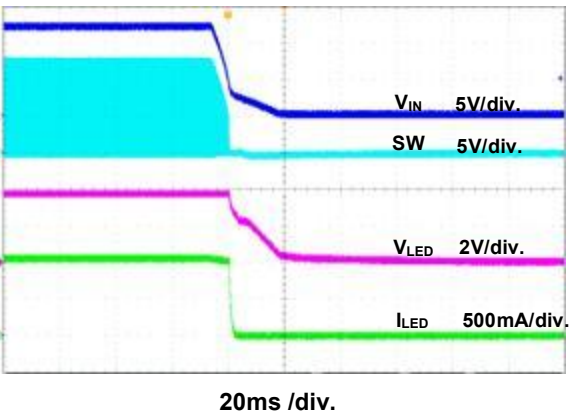

Figure 10. Power Off through V_{IN} Waveform

$V_{IN}=12V, I_{OUT}=1.0A, 1S2P LED$

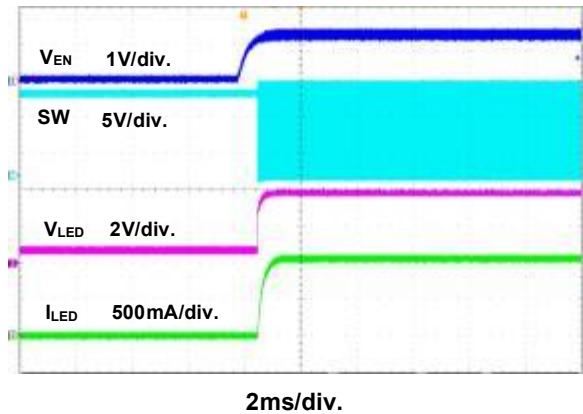

Figure 11. Power On through EN Waveform

Typical Performance Curves (Continued)

V_{IN}=12V, I_{OUT}=1.0A, 1S2P LED

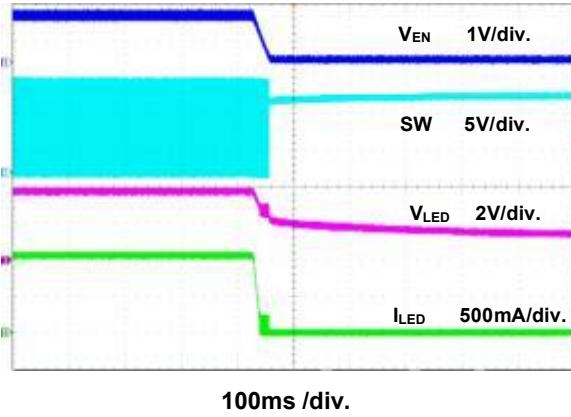

Figure 12. Power Off through V_{EN} Waveform

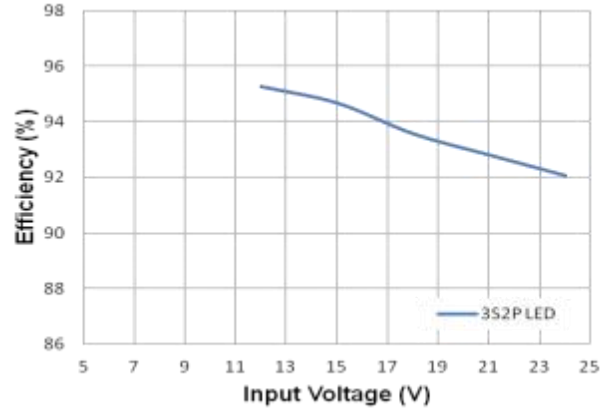

Figure 13. Efficiency vs. Input Voltage

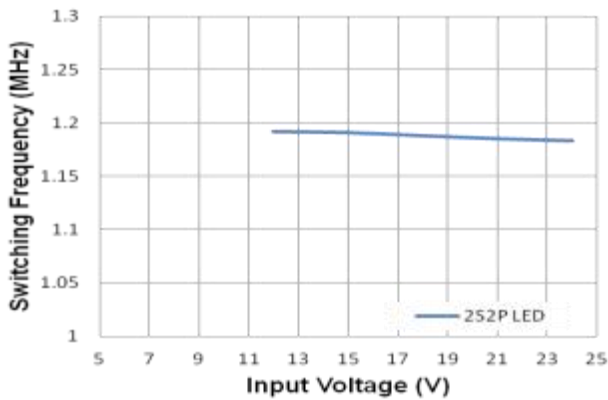

Figure 14. Frequency vs. Input Voltage (I_{OUT}=0.5A)

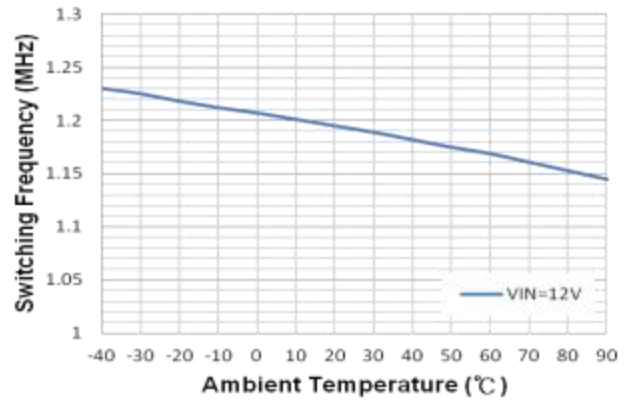

Figure 15. Frequency vs. Temperature (I_{OUT}=0.5A, 2S2P LED)

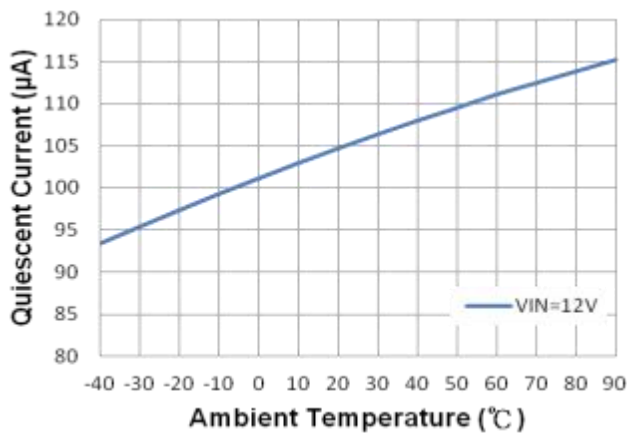

Figure 16. Quiescent Current vs. Temperature

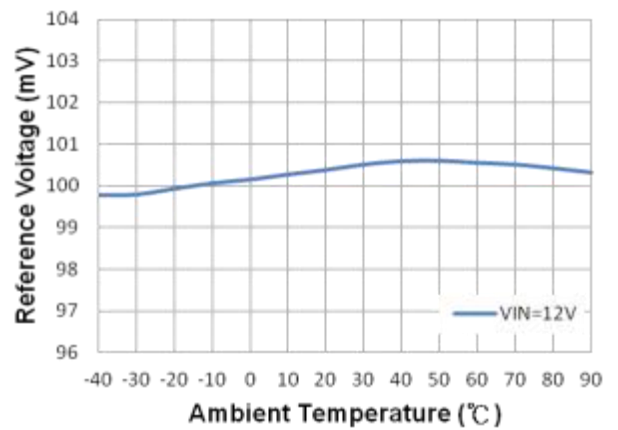

Figure 17. Reference Voltage vs. Temperature (I_{OUT}=0.5A, 2S2P LED)

Typical Performance Curves (Continued)

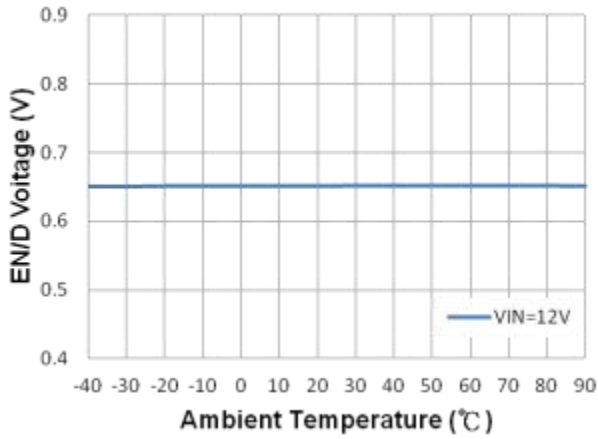

Figure 18. EN/D Voltage vs. Temperature
($I_{out}=0.5A$, 2S2P LED)

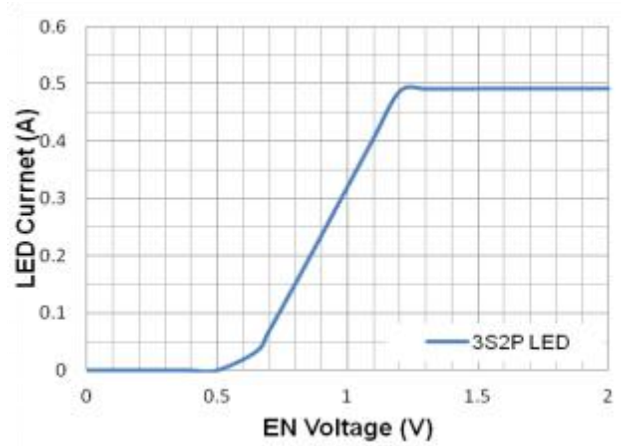

Figure 19. Analog Dimming :ILED vs. EN Voltage
($V_{in}=12V$)

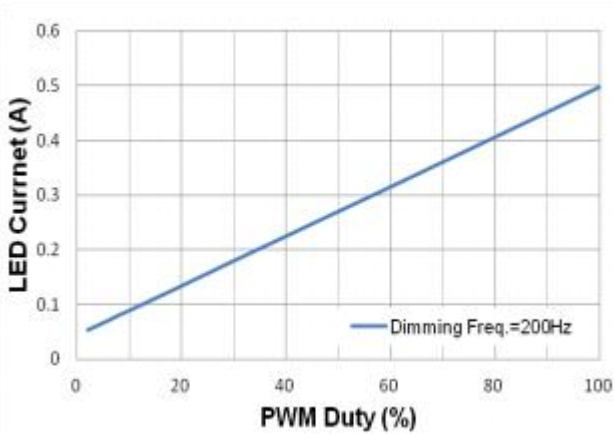

Figure 20. Digital Dimming :ILED vs. PWM Duty
($V_{in}=12V$, 3S2P LED)

Function Description

The FR9703 is constant frequency and current mode control LED driver IC. It has integrated 200mQ power MOSFET, and provides 1.5A output current. It regulates input voltage from 2.8V to 24V.

Internal Compensation Function

The stability of the ISEN circuit is controlled through internal compensation circuits. This internal compensation function is optimized for most applications and this function can reduce external R, C components.

Enable and Dimming Control

The FR9703 EN/D pin provides digital control to enable and disable the converter. When the voltage of EN/D exceeds the threshold voltage, the FR9703 will operate enables. If the EN/D pin voltage is below than the shutdown threshold voltage, the FR9703 will turn into the shutdown mode and the shutdown current is around 10pA (typ). This pin includes a 0.65V to 1.2V analog dimming input which can be used for linear dimming of the LED current. It includes a PWM dimming input that can accept an external control signal with a duty ratio of 5% to 100% and PWM dimming is from 100Hz to 1kHz.

Input Under Voltage Lockout

When the FR9703 is power on, the internal circuits are held inactive until V_{IN} voltage exceeds the input UVLO threshold voltage. And the regulator will be disabled when V_{IN} is below the input UVLO threshold voltage. The hysteric of the UVLO comparator is 200mV (typ).

Input Over Voltage Protection

When the VIN pin voltage exceeds 26.7V, the output over voltage protection function will be triggered and turn off the MOSFET.

Over Current Protection

The FR9703 over current protection function is implemented using cycle-by-cycle current limit architecture. The inductor current is monitored by measuring the MOSFET series sense resistor voltage. When the load current increases, the inductor current also increases. When the inductor current reaches the current limit threshold, the output voltage starts to drop. When the over current condition is removed, the output voltage returns to the regulated value.

Over Temperature Protection

The FR9703 incorporates an over temperature protection circuit to protect itself from overheating. When the junction temperature exceeds the thermal shutdown threshold temperature, the regulator will be shutdown. And the hysteric of the over temperature protection is 20°C (typ).

Application Information

Setting LED Current

The LED current I_{LED} is set using a resistor from the VIN to ISEN. The ISEN pin regulated voltage is 100mV. Thus the LED current is:

$$R_{SEN} = \frac{100mV}{I_{LED}}$$

Input Capacitor Selection

The use of the input capacitor is filtering the input voltage ripple and the MOSFETS switching spike voltage. Because the input current to the step-down converter is discontinuous, the input capacitor is required to supply the current to the converter to keep the DC input voltage. The capacitor voltage rating should be 1.25 to 1.5 times greater than the maximum input voltage. The input capacitor ripple current RMS value is calculated as:

$$I_{CIN(RMS)} = I_{OUT} \sqrt{D(1-D)}$$

$$D = \frac{V_{OUT}}{V_{IN}}$$

Where D is the duty cycle of the power MOSFET. A low ESR capacitor is required to keep the noise minimum. To select the X7R (-55°C to 125°C) or X5R (-55°C to 85°C) ceramic capacitors are better, but tantalum or low ESR electrolytic capacitors may also suffice. When using tantalum or electrolytic capacitors, a 0.1pF ceramic capacitor should be placed as close to the IC as possible.

Output Capacitor Selection

The output capacitor is used to keep the DC output voltage and supply the load transient current. When operating in constant current mode, the output ripple is determined by four components:

$$V_{RIPPLE(t)} = V_{RIPPLE(C)}(t) + V_{RIPPLE(ESR)}(t) + V_{RIPPLE(ESL)}(t) + V_{NOISE}(t)$$

The following figures show the form of the ripple contributions.

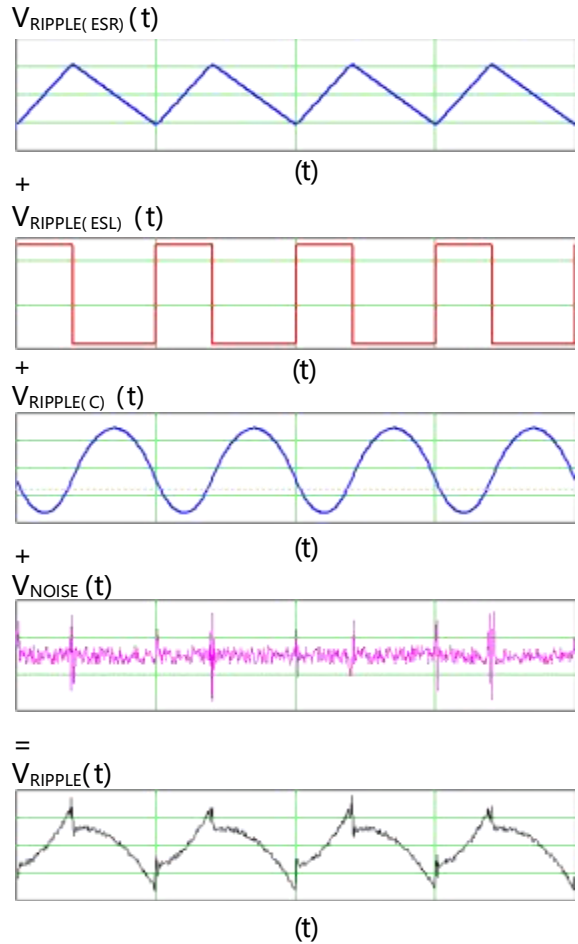

$$V_{RIPPLE(ESR)} = \frac{V_{OUT}}{F_{OSC} L} \left(1 - \frac{V_{OUT}}{V_{IN}}\right) ESR$$

$$V_{RIPPLE(ESL)} = \frac{ESL}{L} V_{IN}$$

$$V_{RIPPLE(C)} = \frac{V_{OUT}}{8 F_{OSC}^2 L C_{OUT}} \left(1 - \frac{V_{OUT}}{V_{IN}}\right)$$

Application Information (Continued)

Where F_{OSC} is the switching frequency, L is the inductance value, V_{IN} is the input voltage, ESR is the equivalent series resistance value of the output capacitor, ESL is the equivalent series inductance value of the output capacitor and the C_{OUT} is the output capacitor.

Low ESR capacitors are preferred to use. Ceramic, tantalum or low ESR electrolytic capacitors can be used depending on the output ripple requirement. When using the ceramic capacitors, the ESL component is usually negligible.

It is important to use the proper method to eliminate high frequency noise when measuring the output ripple. The figure shows how to locate the probe across the capacitor when measuring output ripple. Removing the scope probe plastic jacket in order to expose the ground at the tip of the probe. It gives a very short connection from the probe ground to the capacitor and eliminating noise.

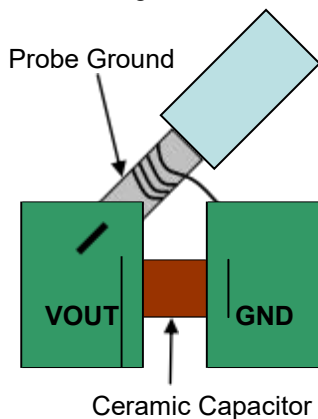

Inductor Selection

The output inductor is used for storing energy and filtering output ripple current. But the trade-off condition often happens between maximum energy storage and the physical size of the inductor. The first consideration for selecting the output inductor is to make sure that the inductance is large enough to keep the converter in the continuous current mode.

That will lower ripple current and result in lower output ripple voltage. The Δ_L is inductor peak-to-peak ripple current:

$$\frac{I}{F}$$

A good compromise value between size and efficiency is to set the peak-to-peak inductor ripple current Δ_L equal to 30% of the maximum load current. But setting the peak-to-peak inductor ripple current Δ_L between 20%~50% of the maximum load current is also acceptable. Then the inductance can be calculated with the following equation:

$$\frac{T(MA)}{F}$$

To guarantee sufficient output current, peak inductor current must be lower than the FR9703 high-side MOSFET current limit. The peak inductor current is as below:

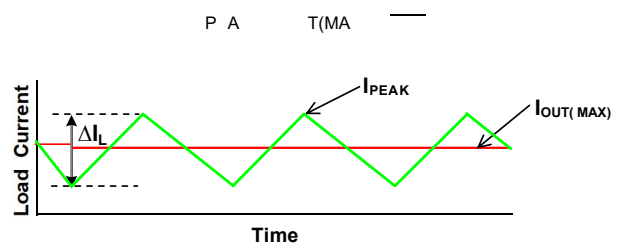

Outline Information

SOT-23-6 Package (Unit: mm)

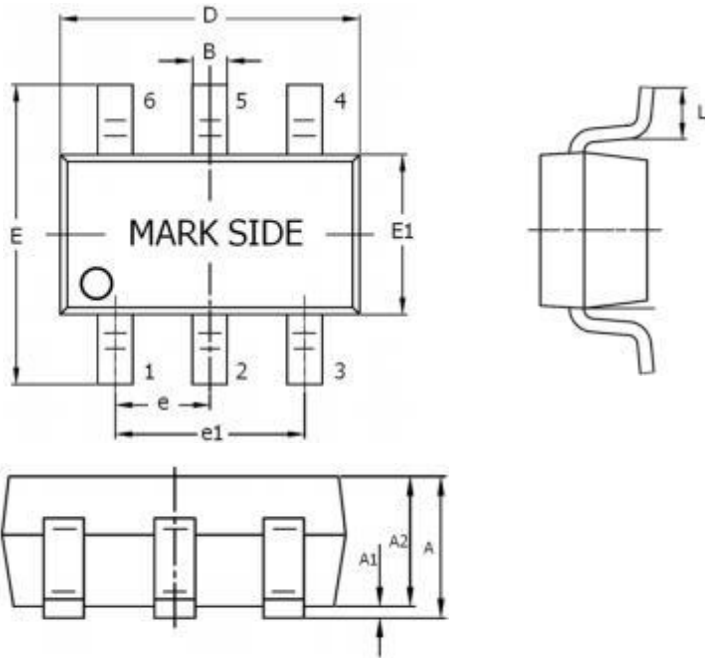

SYMBOLS UNIT	DIMENSION IN MILLIMETER	
	MIN	MAX
A	0.90	1.45
A1	0.00	0.15
A2	0.90	1.30
B	0.30	0.50
D	2.80	3.00
E	2.60	3.00
E1	1.50	1.70
e	0.90	1.00
e1	1.80	2.00
L	0.30	0.60

Note 5: Followed From JEDEC MO- 178-C .
 Note 6: Body dimensions do not include mold flash or protrusion. Mold flash and protrusion shall not exceed 0.3mm.

Carrier dimensions

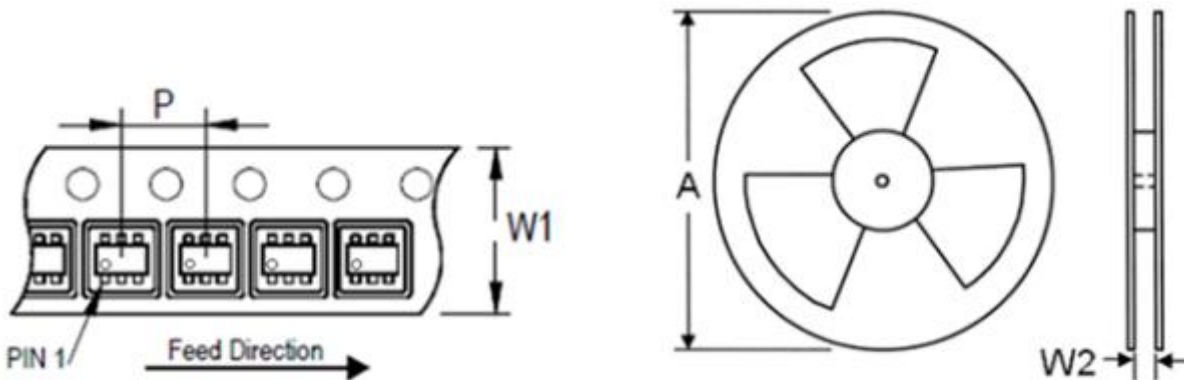

Tape Size (W1) mm	Pocket Pitch (P) mm	Reel Size (A)		Reel Width (W2) mm	Empty Cavity Length mm	Units per Reel
		in	mm			
8	4	7	180	8.4	300~1000	3,000

Life Support Policy

Fitipower's products are not authorized for use as critical components in life support devices or other medical systems .