

SBD Type : FRH10A10

OUTLINE DRAWING

FEATURES

- *Similar to TO-220AB Case
- *Fully Molded Isolation
- *Dual Diodes – Anode Common
- *High Voltage Low Leakage Current
- *Low Forward Voltage Drop
- *Low Power Loss,High Efficiency
- *High Surge Capability
- *Tj=150 °C operation

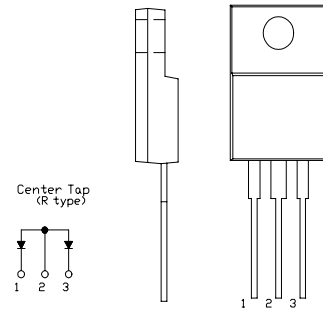

Maximum Ratings

Approx Net Weight: 1.75g

Rating	Symbol	FRH10A10		Unit
Repetitive Peak Reverse Voltage	V_{RRM}	100		V
Average Rectified Output Current	I_O	10	$T_c=122^\circ\text{C}$ 50 Hz Full Sine Wave Resistive Load	A
RMS Forward Current	$I_{F(RMS)}$	11.1		A
Surge Forward Current	I_{FSM}	120	50Hz Full Sine Wave ,1cycle Non-repetitive	A
Operating JunctionTemperature Range	T_{jw}	-40 to +150		°C
Storage Temperature Range	T_{stg}	-40 to +150		°C
Mounting torque	Ftor	recommended torque = 0.5		N•m

Electrical • Thermal Characteristics

Characteristics	Symbol	Conditions	Min.	Typ.	Max.	Unit
Peak Reverse Current	I_{RM}	$T_j= 25^\circ\text{C}$, $V_{RM}= V_{RRM}$ per Arm	-	-	1	mA
Peak Forward Voltage	V_{FM}	$T_j= 25^\circ\text{C}$, $I_{FM}= 5\text{ A}$ per Arm	-	-	0.85	V
Thermal Resistance	Rth(j-c)	Junction to Case	-	-	3	°C /W
	Rth(c-f)	Cace to Fin	-	-	1.5	°C /W

FRH_A_OUTLINE DRAWING (Dimensions in mm)

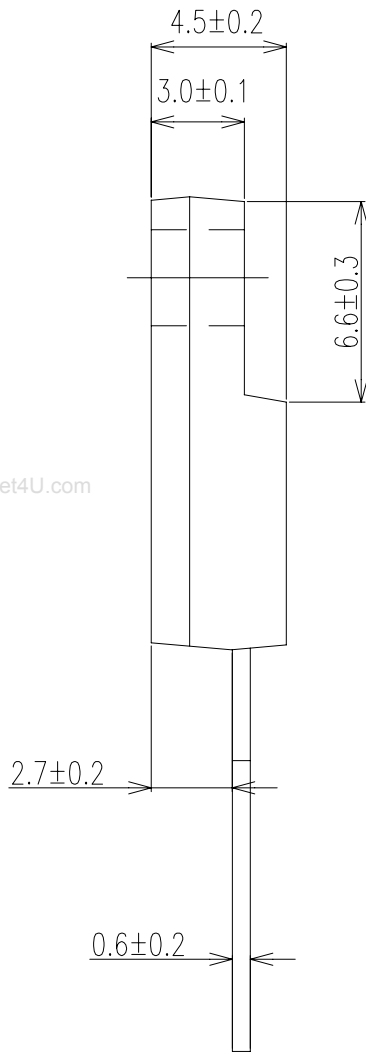

www.DataSheet4U.com

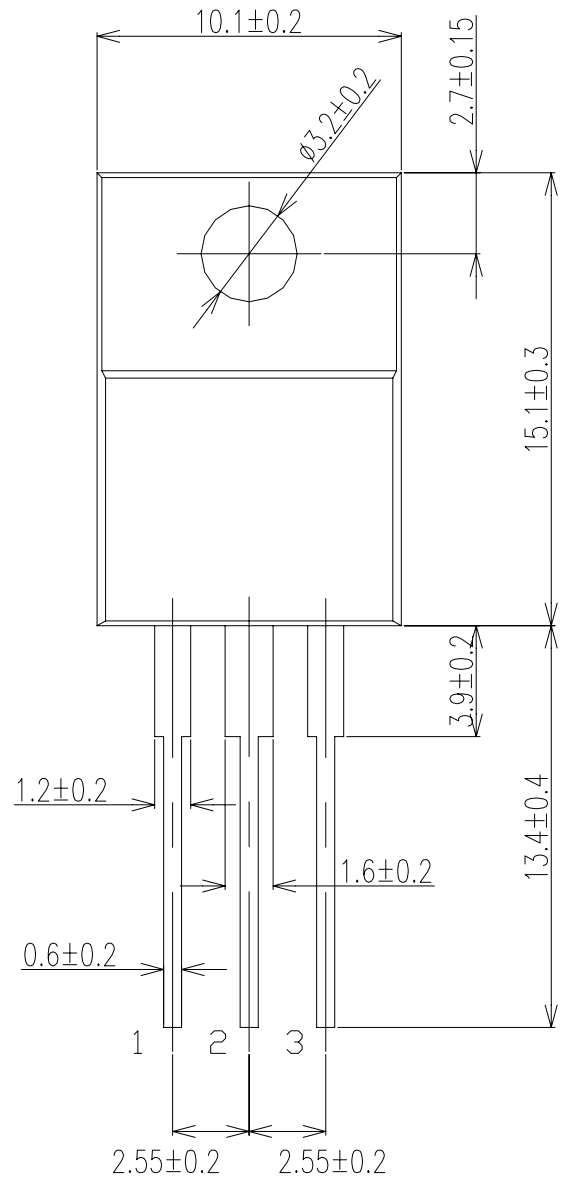

Center Tap
(R type)

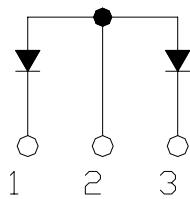

FORWARD CURRENT VS. VOLTAGE

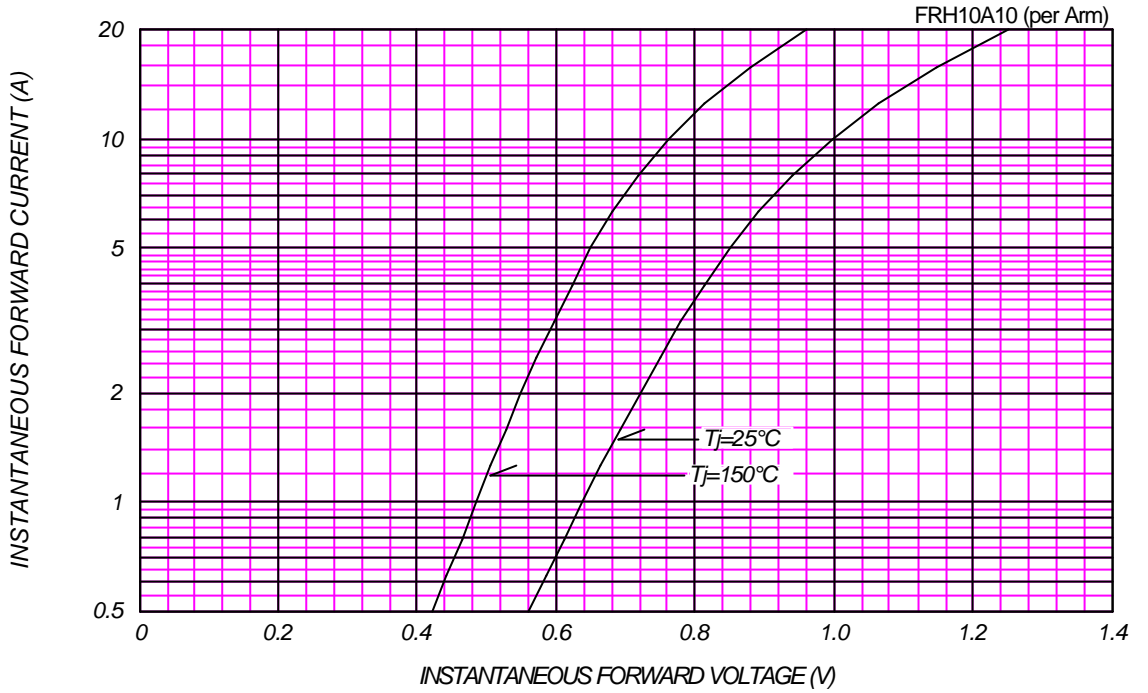

www.DataSheet4U.com

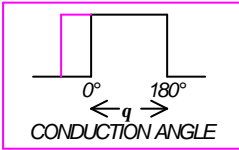

AVERAGE FORWARD POWER DISSIPATION

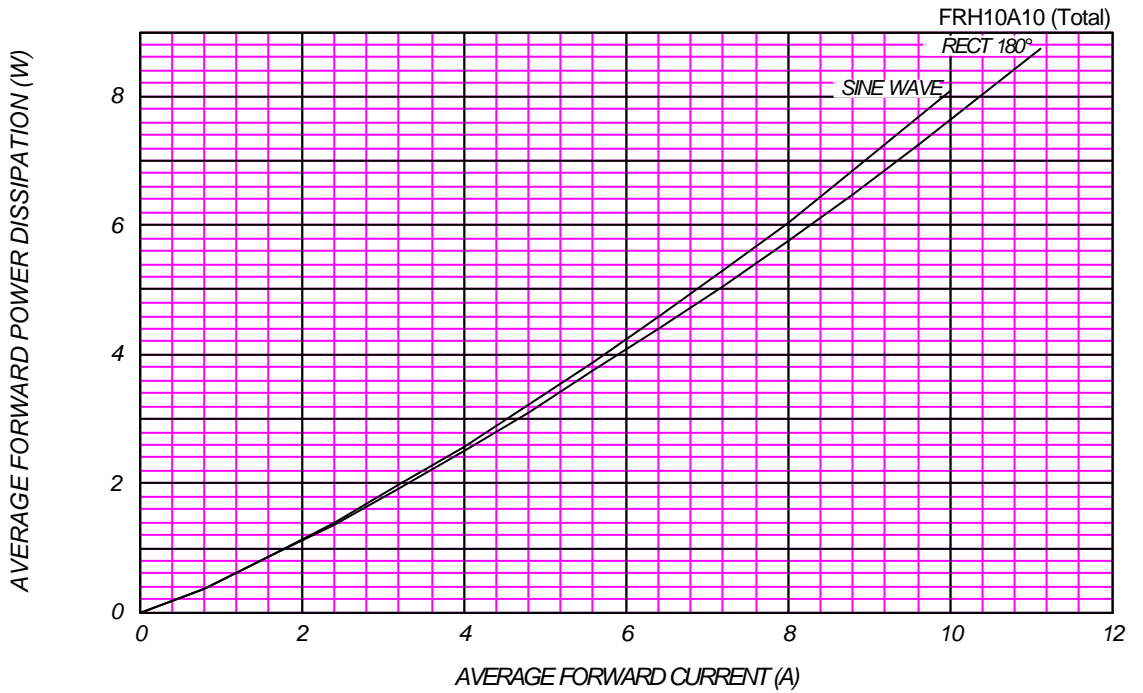

PEAK REVERSE CURRENT VS. PEAK REVERSE VOLTAGE

T_j = 150 °C

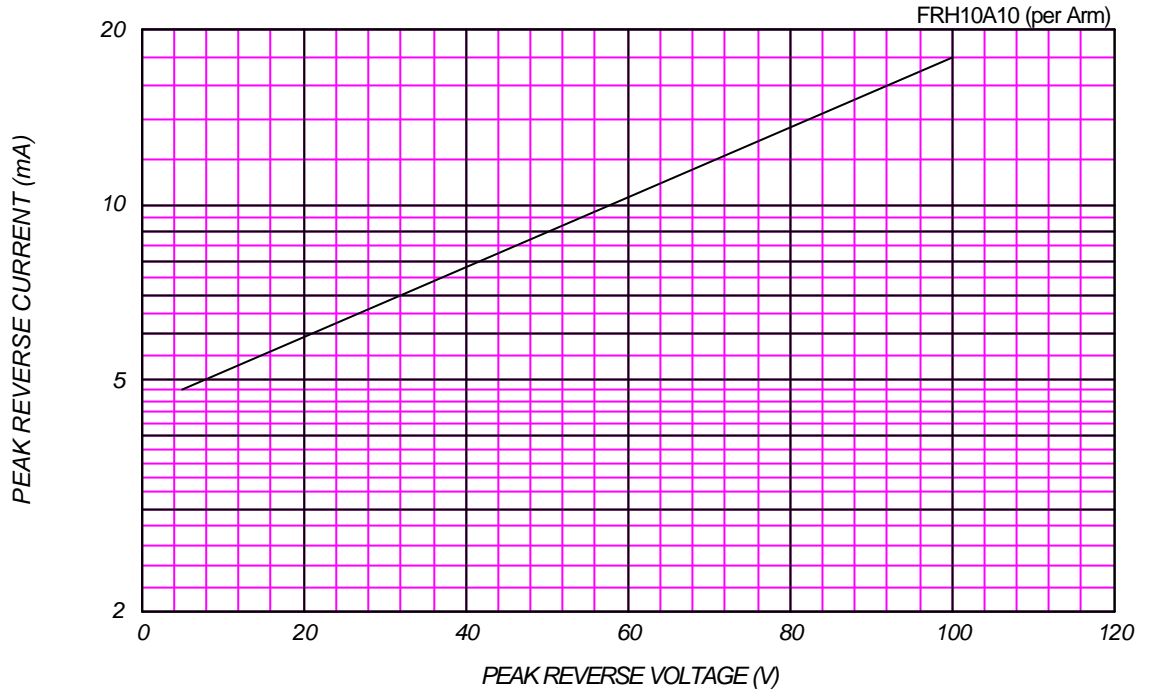

AVERAGE REVERSE POWER DISSIPATION

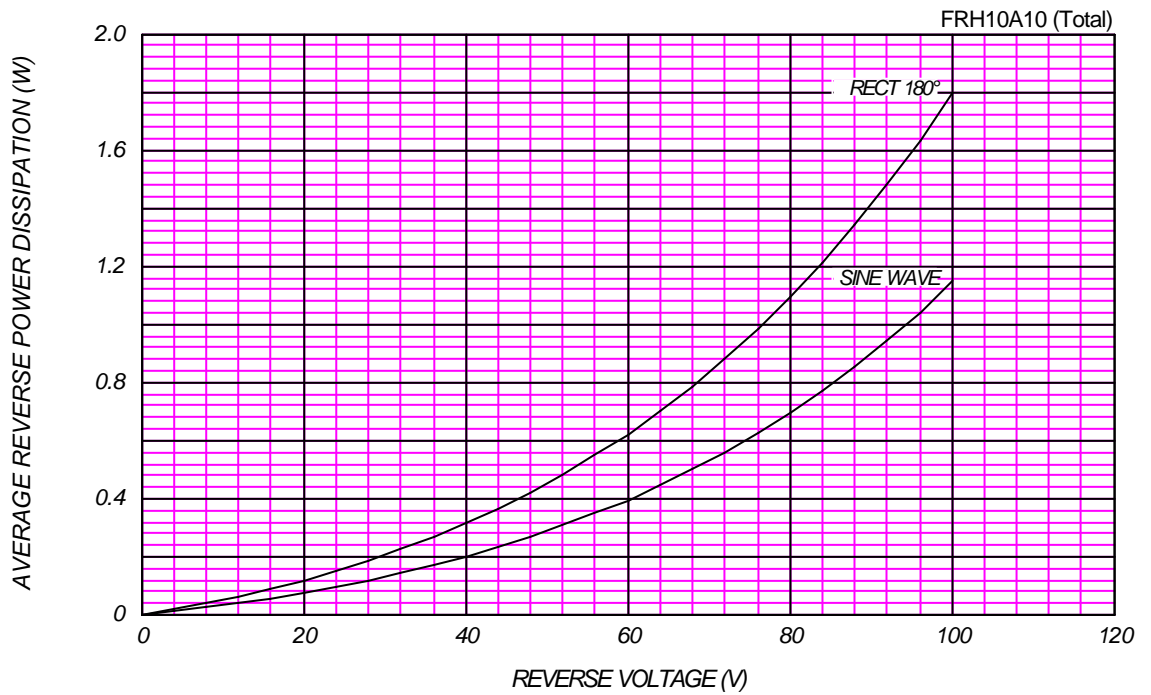



AVERAGE FORWARD CURRENT VS. CASE TEMPERATURE

$V_{RM} = 100V$

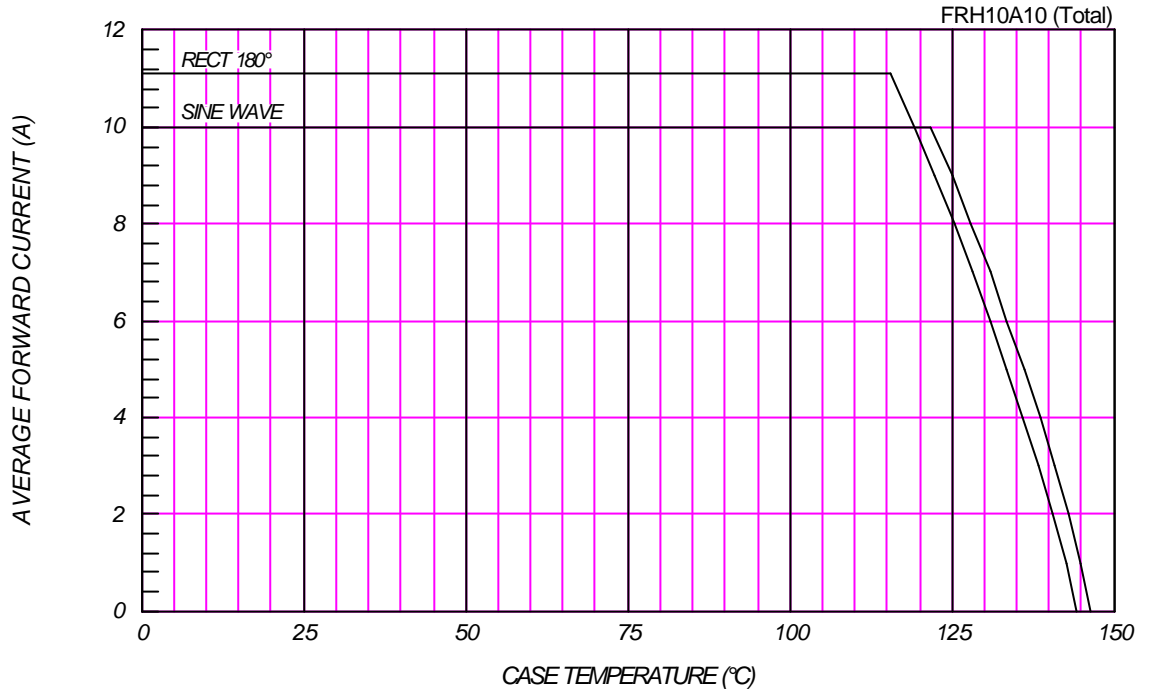

www.DataSheet4U.com

SURGE CURRENT RATINGS

$f = 50\text{Hz}$, Half Sine Wave, Non-Repetitive, No Load

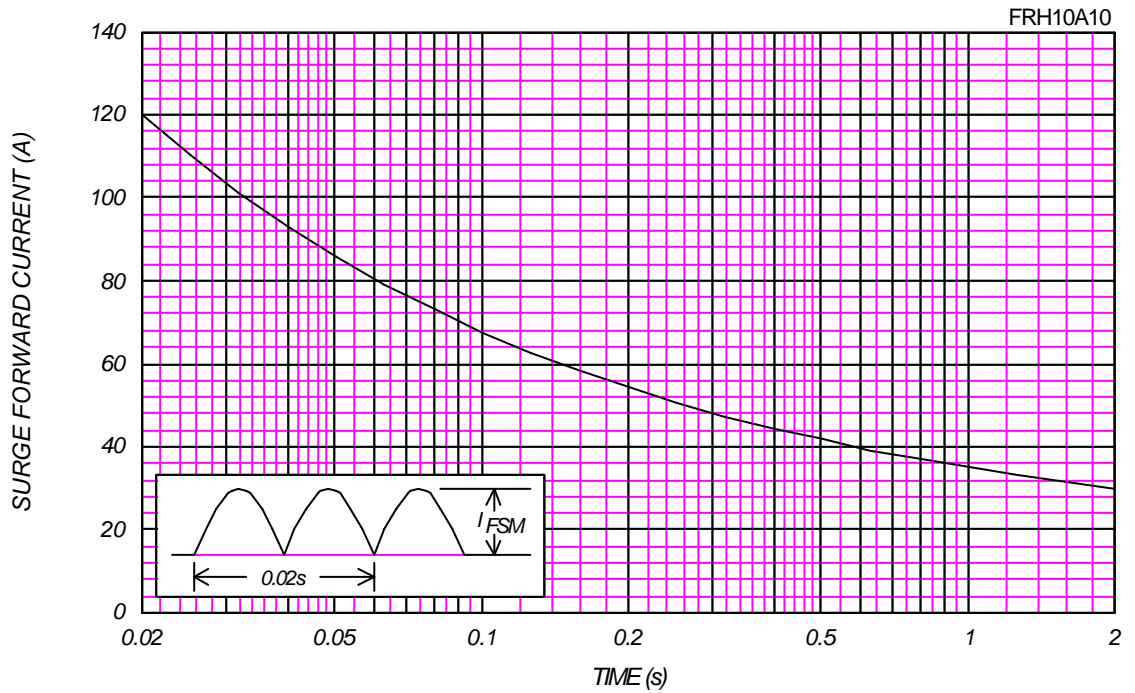

www.DataSheet4U.com

JUNCTION CAPACITANCE VS. REVERSE VOLTAGE

$T_j=25^\circ\text{C}$, $V_m=20\text{mV}_{\text{RMS}}$, $f=100\text{kHz}$, Typical Value

FRH10A10 (per Arm)

