

June 1998

Features

- 11A, -100V, RDS(on) = 0.315Ω
- Second Generation Rad Hard MOSFET Results From New Design Concepts
- Gamma
 - Meets Pre-Rad Specifications to 100KRAD(Si)
 - Defined End Point Specs at 300KRAD(Si) and 1000KRAD(Si)
 - Performance Permits Limited Use to 3000KRAD(Si)
- Gamma Dot
 - Survives 3E9RAD(Si)/sec at 80% BVDSS Typically
 - Survives 2E12 Typically If Current Limited to IDM
- Photo Current
 - 3.0nA Per-RAD(Si)/sec Typically
- Neutron
 - Pre-RAD Specifications for 3E13 Neutrons/cm²
 - Usable to 3E14 Neutrons/cm²

Description

Intersil has designed a series of SECOND GENERATION hardened power MOSFETs of both N and P channel enhancement types with ratings from 100V to 500V, 1A to 60A, and on resistance as low as 25mΩ. Total dose hardness is offered at 100K RAD(Si) and 1000KRAD(Si) with neutron hardness ranging from 1E13n/cm² for 500V product to 1E14n/cm² for 100V product. Dose rate hardness (GAMMA DOT) exists for rates to 1E9 without current limiting and 2E12 with current limiting.

This MOSFET is an enhancement-mode silicon-gate power field effect transistor of the vertical DMOS (VDMOS) structure. It is specially designed and processed to exhibit minimal characteristic changes to total dose (GAMMA) and neutron (n⁰) exposures. Design and processing efforts are also directed to enhance survival to heavy ion (SEE) and/or dose rate (GAMMA DOT) exposure.

This part may be supplied as a die or in various packages other than shown above. Reliability screening is available as either non TX (commercial), TX equivalent of MIL-S-19500, TXV equivalent of MIL-S-19500, or space equivalent of MIL-S-19500. Contact the Intersil Corporation High-Reliability Marketing group for any desired deviations from the data sheet.

Package

TO-257AA

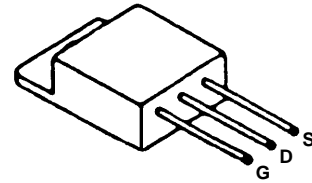

CAUTION: Beryllia Warning per MIL-S-19500 refer to package specifications.

Symbol

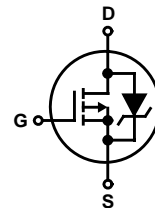

Absolute Maximum Ratings (TC = +25°C) Unless Otherwise Specified

	FRS9140D, R, H	UNITS
Drain-Source Voltage	-100	V
Drain-Gate Voltage (RGS = 20kΩ).	-100	V
Continuous Drain Current		
TC = +25°C	11	A
TC = +100°C	7	A
Pulsed Drain Current	33	A
Gate-Source Voltage	±20	V
Maximum Power Dissipation		
TC = +25°C	75	W
TC = +100°C	30	W
Derated Above +25°C	0.60	W/°C
Inductive Current, Clamped, L = 100μH, (See Test Figure).	33	A
Continuous Source Current (Body Diode)	11	A
Pulsed Source Current (Body Diode)	33	A
Operating And Storage Temperature	-55 to +150	°C
Lead Temperature (During Soldering)		
Distance > 0.063 in. (1.6mm) From Case, 10s Max.	300	°C

FRS9140D, FRS9140R, FRS9140H

Pre-Radiation Electrical Specifications TC = +25°C, Unless Otherwise Specified

PARAMETER	SYMBOL	TEST CONDITIONS	LIMITS		UNITS
			MIN	MAX	
Drain-Source Breakdown Volts	BVDSS	VGS = 0, ID = 1mA	-100	-	V
Gate-Threshold Volts	VGS(th)	VDS = VGS, ID = 1mA	-2.0	-4.0	V
Gate-body Leakage Forward	IGSSF	VGS = -20V	-	100	nA
Gate-Body Leakage Reverse	IGSSR	VGS = +20V	-	100	nA
Zero-Gate Voltage Drain Current	IDSS1	VDS = -100V, VGS = 0	-	1	mA
	IDSS2	VDS = -80V, VGS = 0	-	0.025	
	IDSS3	VDS = -80V, VGS = 0, TC = +125°C	-	0.25	
Rated Avalanche Current	IAR	Time = 20μs	-	33	A
Drain-Source On-State Volts	VDS(on)	VGS = -10V, ID = 11A	-	-3.64	V
Drain-source On Resistance	RDS(on)	VGS = -10V, ID = 7A	-	.315	Ω
Turn-On Delay Time	td(on)	VDD = -50V, ID = 11A	-	70	ns
Rise Time	tr	Pulse Width = 3μs	-	456	
Turn-Off Delay Time	td(off)	Period = 300μs, Rg = 25Ω	-	148	
Fall Time	tf	0 ≤ VGS ≤ 10 (See Test Circuit)	-	100	
Gate-Charge Threshold	QG(th)	VDD = -50V, ID = 11A IGS1 = IGS2 0 ≤ VGS ≤ 20	2	8	nc
Gate-Charge On State	QG(on)		27	108	
Gate-Charge Total	QGM		55	222	
Plateau Voltage	VGP		-3	-14	V
Gate-Charge Source	QGS		6	28	nc
Gate-Charge Drain	QGD		10	42	
Diode Forward Voltage	VSD	ID = 11A, VGD = 0	-0.6	-1.8	V
Reverse Recovery Time	TT	I = 11A; di/dt = 100A/μs	-	300	ns
Junction-To-Case	Rθjc		-	1.67	°C/W
Junction-To-Ambient	Rθja	Free Air Operation	-	60	

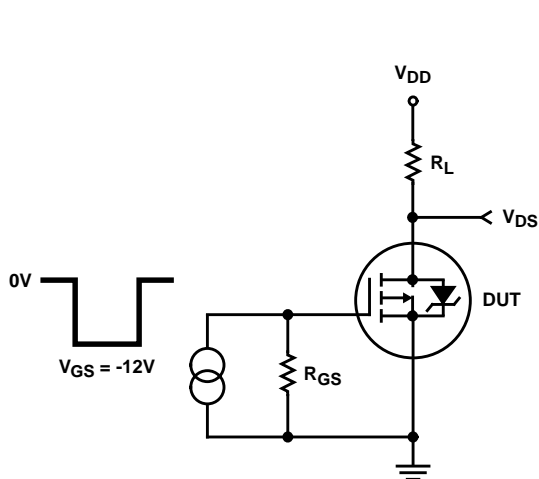

FIGURE 1. RESISTIVE SWITCHING TEST CIRCUIT

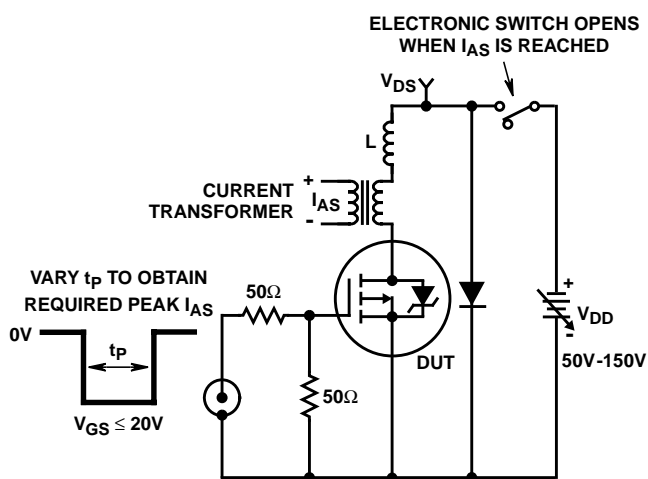

FIGURE 2. UNCLAMPED ENERGY TEST CIRCUIT

FRS9140D, FRS9140R, FRS9140H

Post-Radiation Electrical Specifications TC = +25°C, Unless Otherwise Specified

PARAMETER	SYMBOL	TYPE	TEST CONDITIONS	LIMITS		UNITS	
				MIN	MAX		
Drain-Source Breakdown Volts	(Note 4, 6)	BVDSS	FRS9140D, R	VGS = 0, ID = 1mA	-100	-	V
	(Note 5, 6)	BVDSS	FRS9140H	VGS = 0, ID = 1mA	-95	-	V
Gate-Source Threshold Volts	(Note 4, 6)	VGS(th)	FRS9140D, R	VGS = VDS, ID = 1mA	-2.0	-4.0	V
	(Note 3, 5, 6)	VGS(th)	FRS9140H	VGS = VDS, ID = 1mA	-2.0	-6.0	V
Gate-Body Leakage Forward	(Note 4, 6)	IGSSF	FRS9140D, R	VGS = -20V, VDS = 0	-	100	nA
	(Note 5, 6)	IGSSF	FRS9140H	VGS = -20V, VDS = 0	-	200	nA
Gate-Body Leakage Reverse	(Note 2, 4, 6)	IGSSR	FRS9140D, R	VGS = +20V, VDS = 0	-	100	nA
	(Note 2, 5, 6)	IGSSR	FRS9140H	VGS = +20V, VDS = 0	-	200	nA
Zero-Gate Voltage Drain Current	(Note 4, 6)	IDSS	FRS9140D, R	VGS = 0, VDS = -80V	-	25	μA
	(Note 5, 6)	IDSS	FRS9140H	VGS = 0, VDS = -80V	-	100	μA
Drain-Source On-state Volts	(Note 1, 4, 6)	VDS(on)	FRS9140D, R	VGS = -10V, ID = 11A	-	-3.64	V
	(Note 1, 5, 6)	VDS(on)	FRS9140H	VGS = -16V, ID = 11A	-	-5.46	V
Drain-Source On Resistance	(Note 1, 4, 6)	RDS(on)	FRS9140D, R	VGS = -10V, ID = 7A	-	.315	Ω
	(Note 1, 5, 6)	RDS(on)	FRS9140H	VGS = -14V, ID = 7A	-	.473	Ω

NOTES:

1. Pulse test, 300μs max
2. Absolute value
3. Gamma = 300KRAD(Si)
4. Gamma = 10KRAD(Si) for "D", 100KRAD(Si) for "R". Neutron = 3E13
5. Gamma = 1000KRAD(Si). Neutron = 3E13
6. Insitu Gamma bias must be sampled for both VGS = -10V, VDS = 0V and VGS = 0V, VDS = 80% BVDSS
7. Gamma data taken 5/19/90 on TA17741 devices by GE ASTRO SPACE; EMC/SURVIVABILITY LABORATORY; KING OF PRUSSIA, PA 19401
8. Single event drain burnout testing by Titus, J.L., et al of NWSC, Crane, IN at Brookhaven Nat. Lab. Dec 11-14, 1989
9. Neutron derivation, INTERSIL Application note AN-8831, Oct. 1988

Typical Performance Characteristics

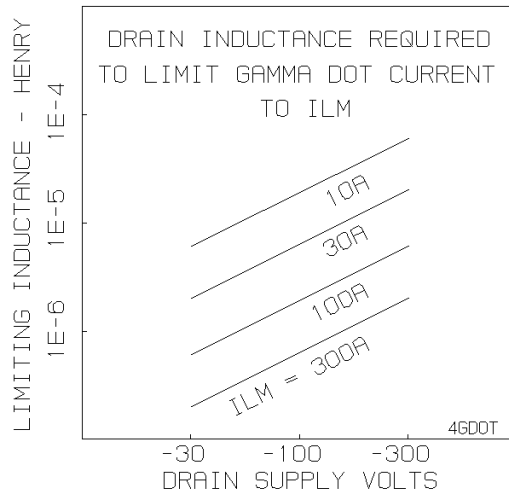
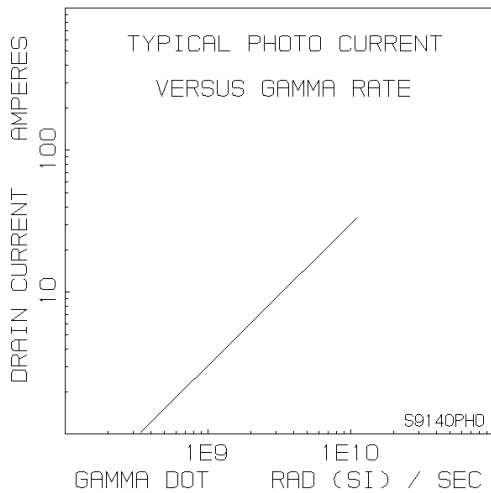
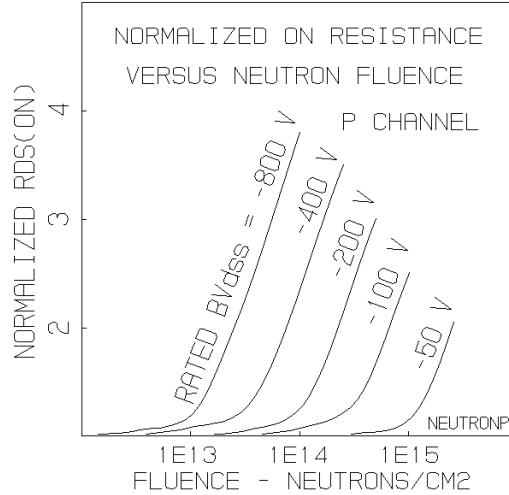
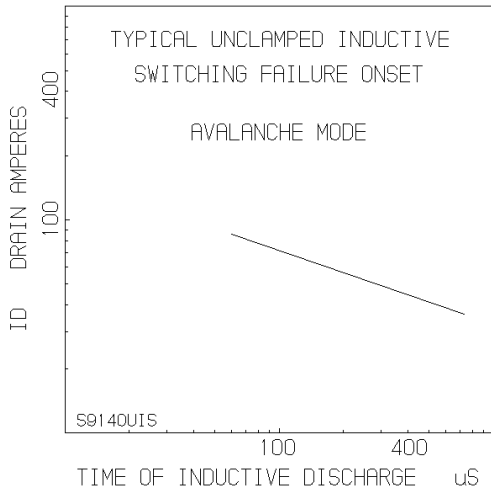
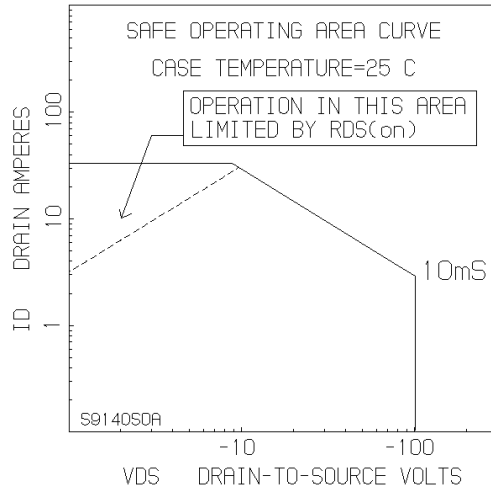
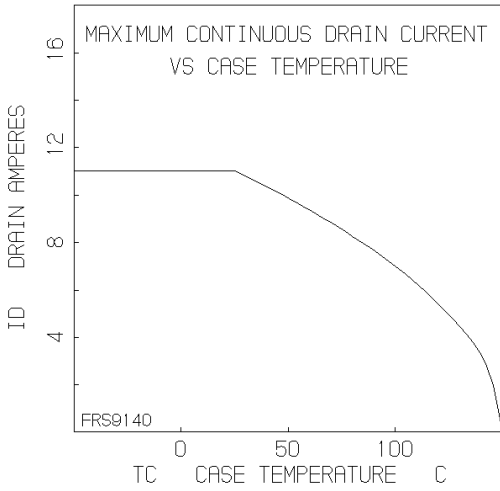

Rad Hard Data Packages - Intersil Power Transistors

TXV Equivalent

1. Rad Hard TXV Equivalent - Standard Data Package

- A. Certificate of Compliance
- B. Assembly Flow Chart
- C. Preconditioning - Attributes Data Sheet
- D. Group A - Attributes Data Sheet
- E. Group B - Attributes Data Sheet
- F. Group C - Attributes Data Sheet
- G. Group D - Attributes Data Sheet

2. Rad Hard TXV Equivalent - Optional Data Package

- A. Certificate of Compliance
- B. Assembly Flow Chart
- C. Preconditioning - Attributes Data Sheet
 - Precondition Lot Traveler
 - Pre and Post Burn-In Read and Record Data
- D. Group A - Attributes Data Sheet
 - Group A Lot Traveler
- E. Group B - Attributes Data Sheet
 - Group B Lot Traveler
 - Pre and Post Read and Record Data for Intermittent Operating Life (Subgroup B3)
 - Bond Strength Data (Subgroup B3)
 - Pre and Post High Temperature Operating Life Read and Record Data (Subgroup B6)
- F. Group C - Attributes Data Sheet
 - Group C Lot Traveler
 - Pre and Post Read and Record Data for Intermittent Operating Life (Subgroup C6)
 - Bond Strength Data (Subgroup C6)
- G. Group D - Attributes Data Sheet
 - Group D Lot Traveler
 - Pre and Post RAD Read and Record Data

Class S - Equivalents

1. Rad Hard "S" Equivalent - Standard Data Package

- A. Certificate of Compliance
- B. Serialization Records
- C. Assembly Flow Chart
- D. SEM Photos and Report

- E. Preconditioning Attributes Data Sheet
 - Hi-Rel Lot Traveler
 - HTRB - Hi Temp Gate Stress Post Reverse Bias Data and Delta Data
 - HTRB - Hi Temp Drain Stress Post Reverse Bias Delta Data

- F. Group A - Attributes Data Sheet
- G. Group B - Attributes Data Sheet
- H. Group C - Attributes Data Sheet
- I. Group D - Attributes Data Sheet

2. Rad Hard Max. "S" Equivalent - Optional Data Package

- A. Certificate of Compliance
- B. Serialization Records
- C. Assembly Flow Chart
- D. SEM Photos and Report
- E. Preconditioning - Attributes Data Sheet
 - Hi-Rel Lot Traveler
 - HTRB - Hi Temp Gate Stress Post Reverse Bias Data and Delta Data
 - HTRB - Hi Temp Drain Stress Post Reverse Bias Delta Data
 - X-Ray and X-Ray Report
- F. Group A - Attributes Data Sheet
 - Hi-Rel Lot Traveler
 - Subgroups A2, A3, A4, A5 and A7 Data
- G. Group B - Attributes Data Sheet
 - Hi-Rel Lot Traveler
 - Subgroups B1, B3, B4, B5 and B6 Data
- H. Group C - Attributes Data Sheet
 - Hi-Rel Lot Traveler
 - Subgroups C1, C2, C3 and C6 Data
- I. Group D - Attributes Data Sheet
 - Hi-Rel Lot Traveler
 - Pre and Post Radiation Data

FRS9140D, FRS9140R, FRS9140H

TO-257AA

3 LEAD JEDEC TO-257AA HERMETIC METAL PACKAGE

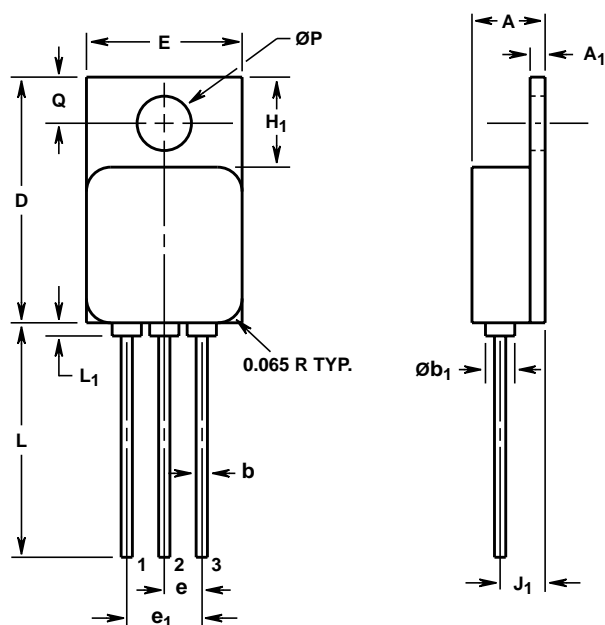

SYMBOL	INCHES		MILLIMETERS		NOTES
	MIN	MAX	MIN	MAX	
A	0.190	0.200	4.83	5.08	-
A ₁	0.035	0.045	0.89	1.14	-
Øb	0.025	0.035	0.64	0.88	2, 3
Øb ₁	0.060	0.090	1.53	2.28	-
D	0.645	0.665	16.39	16.89	-
E	0.410	0.420	10.42	10.66	-
e	0.100 TYP		2.54 TYP		4
e ₁	0.200 BSC		5.08 BSC		4
H ₁	0.230	0.250	5.85	6.35	-
J ₁	0.110	0.130	2.80	3.30	4
L	0.600	0.650	15.24	16.51	-
L ₁	-	0.035	-	0.88	-
ØP	0.140	0.150	3.56	3.81	-
Q	0.113	0.133	2.88	3.37	-

NOTES:

1. These dimensions are within allowable dimensions of Rev. B of JEDEC TO-257AA dated 9-88.
2. Add typically 0.002 inches (0.05mm) for solder coating.
3. Lead dimension (without solder).
4. Position of lead to be measured 0.150 inches (3.81mm) from bottom of dimension D.
5. Die to base BeO isolated, terminals to case ceramic isolated.
6. Controlling dimension: Inch.
7. Revision 1 dated 1-93.

WARNING!

BERYLLIA WARNING PER MIL-S-19500

Packages containing beryllium oxide (BeO) shall not be ground, machined, sandblasted, or subject to any mechanical operation which will produce dust containing any beryllium compound. Packages containing any beryllium compound shall not be subjected to any chemical process (etching, etc.) which will produce fumes containing beryllium or its' compounds.