



## Key-Operated Safety Switches with Solenoid FS 2096-D024-F

### Description

GE Interlogix Industrial Key-Operated Safety Switches with Solenoid Release utilize a removable stainless steel key to provide a positive means of turning the control power off should an access panel, door, gate, guard, etc. be opened during machine operation. This series of switches also includes a solenoid built into the switch and is used to protect an area where access is to be strictly controlled. Prime candidates for this series of safety switches are equipment that cannot be shutdown in mid cycle, machines that have large mechanical inertia, high temperatures or other areas that cannot be immediately entered.

The Key Operated Safety Switch with Solenoid Release denies access to the protected area until the operator electrically allows the release of the key. There are two versions of the Key-Operated Safety Switch with Solenoid Release, Series “D” (de-energized) and “E” (energized). With the key removed, access is allowed through the guard, gate, etc., to be opened. Since the safety switch contacts can only be closed when the key is installed in the switch, the machine cannot be restarted until the guard, gate, etc., is closed. This re-establishes the protection around the machine.

The Series “D” switch locks in the key when the solenoid is “de-energized” (without power). To remove the key, power must be applied to the solenoid, which transfers the contacts. Reinserting the key, when the power is removed from the solenoid transfers the contacts and locks the key in place until power is applied to the solenoid. If power is lost, the Series “D” switch is equipped with a manual release to allow key removal.

The Series “E” switch locks in the key when the solenoid is “energized” (powered up). The key is unlocked when power is removed from the solenoid. The key must be in place before powering up the Series “E” switch or the contacts will not be transferred. CAUTION: The Series “E” switch will also allow the key to be removed should there be a power failure. This is an important consideration when using this Series in safety applications.

### General Specifications

#### Enclosure

Polymeric glass-reinforced, self-extinguishing, shockproof thermal-plastic providing double insulation

#### Standards

Use of this device implies compliance with standards:

EN 954-1, EN 60 204-1, EN 1088, UL508, IEC 947-5-1, EN 1088, BG-GS-ET-19, EN50081-1, EN50082-2, 89/392/CEE, 73/23/CEE, 89/336/CEE, 93/68/CEE.

#### Order Information<sup>1</sup>

Model Number	Body Material	Contact <sup>2</sup> Config.	Contact Operating Voltage, Max.	Short Circuit Protection, Max.
FS 2096-D024-F1	Thermal Plastic	2 N.C. + 1 N.O.	600 VAC, 300 VDC <sup>4</sup>	10A fuse
FS 2096-E024-F1	Thermal Plastic	2 N.C. + 1 N.O.	600 VAC, 300 VDC <sup>4</sup>	10A fuse

#### Electrical Specifications

#### Contact rating<sup>3</sup>

UL/CSA IEC	10A A600/Q300 <sup>4</sup> (UL 508) AC15			DC13	
Volts	250	400	500	24	125 250
Current (A)	3	1	6	1.1	0.4

**Warning— Each electrical rating is an individual maximum and cannot be exceeded!**

- Switches are furnished standard with F1 (90°) key. Other key styles available on Accessories page. Switches are available with either a Power Key Release Solenoid type (D24) or a Power Key Retain Solenoid type (E24). Solenoid types are NOT convertible in the field.
- Configuration with key in
- POSITIVE DOUBLE BREAK CONTACTS. Electrically isolated contacts allow different voltages placed on contact poles.
- UL508

# FS 2096-D024-F

# FS 2096-E024-F

SAFETY MECHANICAL SWITCHES

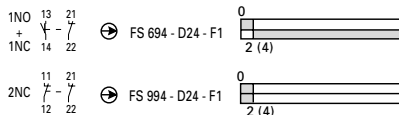
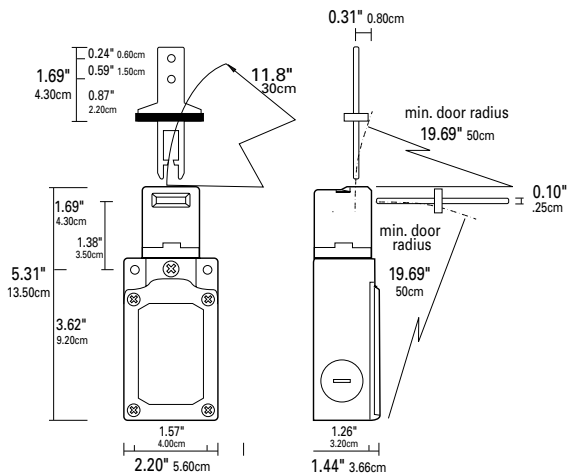

## General Specifications (continued)

### Conduit entry

One entry	PG 13.5	
Adapter not furnished	Order P/N	IN12135

### Mechanical endurance

Life Cycle	800,000 operations
Operating temperature range	-13° to +140°F (-25° to +60° C)
Maximum activating speed	19.5 inches / sec (0.5m/s)
Minimum activating speed	0.039 inches / sec (1mm/s)
Maximum Opening Frequency	120 Openings per hour

Maximum Holding Force 225 lbs. (1,000 N)

### Protection class

IP 66 (according to IEC529)

### Terminal Screws

Captive with self-lifting pressure plates

### Minimum Door Radius

Side 11.8" (30cm)

Front 19.7" (50cm)

### Positive Double Break Contacts

### Solenoid

Operating Voltage 24 Volts AC/DC (+10%/-10%)

Inrush Current 96 VA (0.1 sec)

Holding Current 20 VA

*NOTE: Switch contacts are pilot duty and are not switchable to sustain a motor load.*

## Installation

1. Safety circuits must be connected to the normally closed (NC) contact (11-12 or 21-22). Contacts are normally closed when the key is inserted into the switch. The contacts are opened when the key is removed from the switch. Normally open (NO) contacts (13-14) are for indicating circuits and are not for use in the safety circuit.
2. Mount the switch and key into the machine using tamper resistant fasteners (not supplied). Always use washers under the switch mounting fasteners to prevent the fasteners from pulling through the switch mounting holes. See figure 1.
3. The head of the switch can be rotated in 4 x 90 degree steps. The head of the switch has 2 key openings allowing 8 different key entry positions. To rotate the head, insert the key, remove the 2 head attachment screws, rotate the head into the proper position, reinsert the head attachment screws. It is recommended the head be locked into position by replacing the 2 head attachment screws with tamper proof screws (not provided). See figure 2.
4. Always insert the dust protection plug into the unused port in the key head.
5. When the key is removed from the switch, take care to protect the key entrance from dust and dirt.
6. Verify proper Safety Switch operation before placing the machine in service. Key Operated Safety Switches with Solenoid Release can protect areas where an operator can physically enter.
7. To prevent accidental closing of the door with the operator inside, padlocks can be placed through the hole in the switch key. Minimum diameter of the lock shank is 1/4" (6mm). See figure 3.
8. The switch is not to be used as a mechanical stop.

Figure 1

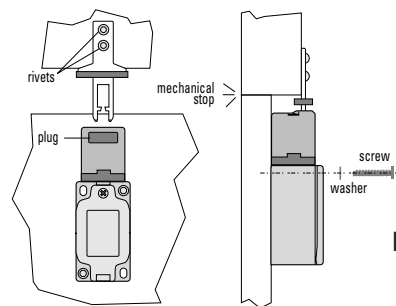

Head Screw Tightening  
Torque = 7 inch lb. (0.8Nm)

Figure 2

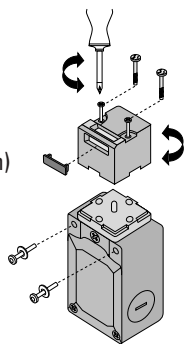

Figure 3

