

### General Description

The FS8853A is a low-dropout linear regulator with ON/OFF control. The device operates in the input voltage range from +2.5V to +9.0V and delivers 300mA output current.

The high-accuracy ( $\pm 35\text{mV}$ ) output voltage is preset at an internally trimmed voltage 2.5V, 2.85V or 3.3V. Other output voltages can be mask-optional from 1.3V to 5.0V with 100mV increment, except FS8853A-29Cx which has 2.85V output voltage.

The FS8853A consists of a 1.25V reference compare amplifier, a P-channel pass transistor, and an enable/disable logic circuit. Other features include short-circuit protection and thermal shutdown protection. The FS8853 devices are available in SOT-89-5 and SOT-23-5 packages.

### Features

- Low dropout voltage 400mV at 300mA (Typ.)
- Low 40 $\mu\text{A}$  current consumption (Typ.) at  $V_{in}=5\text{V}$
- High accuracy output voltage:  $\pm 35\text{mV}$   
Preset at 2.5V, 2.85V, 3.3V  
Mask options from 1.5V to 5.0V
- Small output capacitor
- Output current limit
- Short circuit current limit protection
- Thermal overload shutdown protection
- ON/OFF Control Function
- SOT-89-5 and SOT-23-5 Package

### Applications

- Battery-Powered Devices
- Personal Communication Devices
- Home Electric/Electronic Appliances

### Ordering Information

FS8853A-xx xx

Package	Pin Out		
A : SOT-23-5	1.IN	2.GND	3.EN
	4.NC	5.OUT	
B : SOT-23-5	1.EN	2.GND	3.NC
	4.OUT	5.IN	
C : SOT-23-5	1.GND	2.IN	3.OUT
	4.NC	5.EN	
D : SOT-89-5	1.OUT	2.GND	3.NC
	4.EN	5.IN	
E : SOT-89-5	1.EN	2.GND	3.NC
	4.OUT	5.IN	
F : SOT-89-5	1.GND	2.IN	3.OUT
	4.NC	5.EN	

Temperature Range

- C : Commercial Standard
- P : Commercial Standard, Lead(Pb) Free and Phosphorous(P) Free Package

Output Voltage

15 : 1.5V	27 : 2.7V	39 : 3.9V
16 : 1.6V	28 : 2.8V	40 : 4.0V
17 : 1.7V	<b>29 : 2.85V</b>	41 : 4.1V
18 : 1.8V	30 : 3.0V	42 : 4.2V
19 : 1.9V	31 : 3.1V	43 : 4.3V
20 : 2.0V	32 : 3.2V	44 : 4.4V
21 : 2.1V	<b>33 : 3.3V</b>	45 : 4.5V
22 : 2.2V	34 : 3.4V	46 : 4.6V
23 : 2.3V	35 : 3.5V	47 : 4.7V
24 : 2.4V	36 : 3.6V	48 : 4.8V
<b>25 : 2.5V</b>	37 : 3.7V	49 : 4.9V
26 : 2.6V	38 : 3.8V	50 : 5.0V

Note : *Output Voltage is preset at 2.5V, 2.85V or 3.3V, and standard package type is 'A' type. Mask option output voltages and other package types are available by special order only.*

## Pin Configurations

Part No.	Pin 1	Pin 2	Pin 3	Pin 4	Pin 5
FS8853A-xxxA	IN	GND	EN	NC	OUT
FS8853A-xxxB	EN	GND	NC	OUT	IN
FS8853A-xxxC	GND	IN	OUT	NC	EN

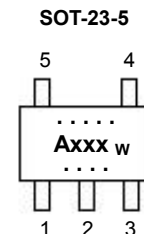

Part No.	Pin 1	Pin 2	Pin 3	Pin 4	Pin 5
FS8853A-xxxD	OUT	GND	NC	EN	IN
FS8853A-xxxE	EN	GND	NC	OUT	IN
FS8853A-xxxF	GND	IN	OUT	NC	EN

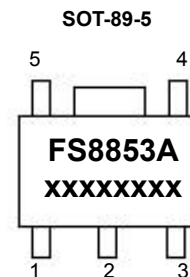

## Package Marking Information

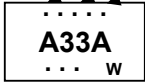
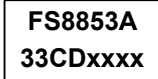
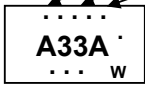
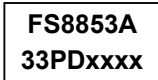
SOT-23-5	SOT-89-5
<p>EX : FS8853A-33CA</p>  <p>Top Point : Lot No. Bottom Point : Year w : week, A~Z &amp; A~Z</p>	<p>EX : FS8853A-33CD</p>  <p>xxxx : Date Code</p>
<p>EX : FS8853A-33PA</p>  <p>Top Point : Lot No. Bottom Point : Year w : week, A~Z &amp; A~Z A dot after marking : Pb/P Free</p>	<p>EX : FS8853A-33PD</p>  <p>xxxx : Date Code</p>

## Pin Description

Part NO.	Symbol	Description
FS8853A-xxCA	GND	Ground pin.
FS8853A-xxCB	IN	Regulator input pin.
FS8853A-xxCC	NC	No Connection.
FS8853A-xxCD	EN	Chip enable pin.
FS8853A-xxCE	OUT	Regulator output pin.
FS8853A-xxCF		

**IN** is the regulator input pin. Supply voltage can range from 2.5V to 9.0V. Bypass with a 1 $\mu$ F capacitor to GND.

**OUT** is the output voltage pin. Sources up to 300mA. Bypass with a 3.3 $\mu$ F capacitor to GND.

**GND** provides the reference for all voltages.

**NC** no connection.

**EN** is output voltage ON/OFF control pin. EN pin input voltage must be less than the input voltage at IN pin.

## Functional Block Diagram

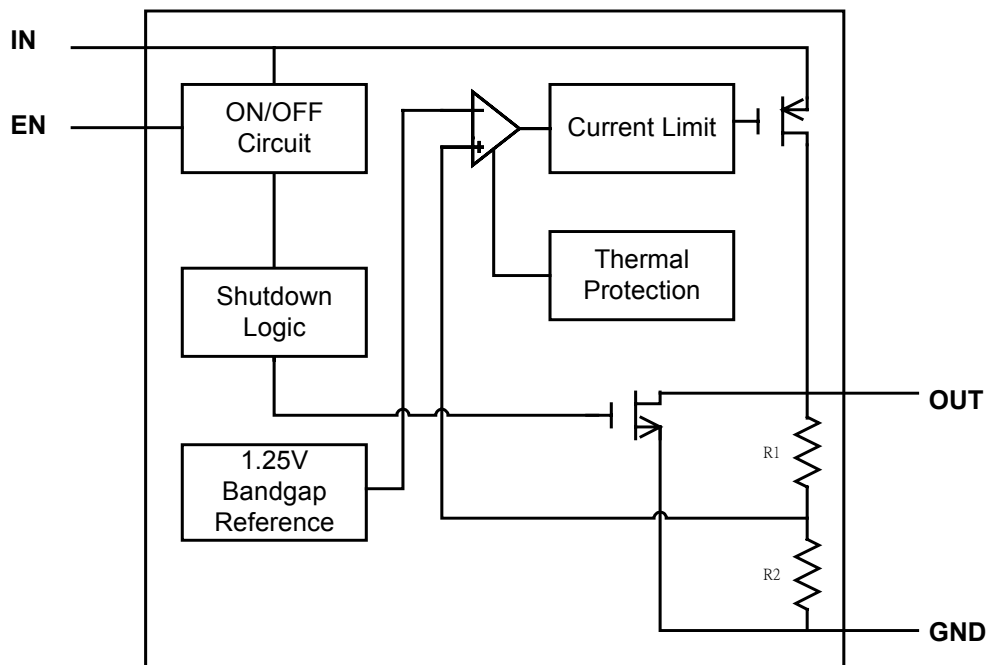

## Typical Application Circuit

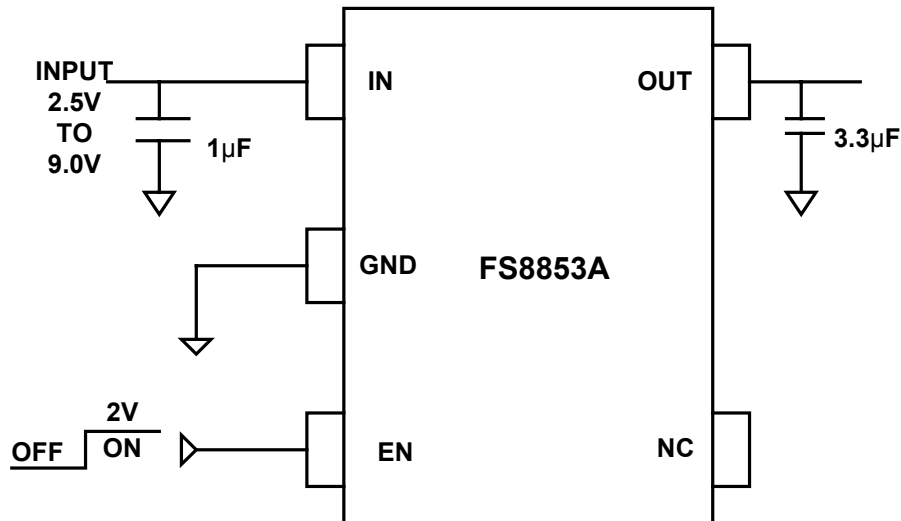

\*Note : EN pin input voltage must always  $\leq$  input voltage.

## Absolute Maximum Ratings

Input voltage $V_{IN}$ to GND	-----	10V
Output current limit, $I_{LIMIT}$	-----	0.5A
Continuous power dissipation, $P_D$ ( $\Delta T = T_J - T_A = 100^\circ C$ )		
SOT-23-5	-----	0.40W
SOT-89-5	-----	0.55W
* The power dissipation values are based on the condition that junction temperature $T_J$ and ambient temperature $T_A$ difference is $100^\circ C$ .		
Junction Temperature, $T_J$	-----	$+155^\circ C$
Storage temperature range, $T_{STG}$	-----	$-55^\circ C$ to $+150^\circ C$
Operating junction temperature range	-----	$-40^\circ C$ to $+125^\circ C$
Lead temperature (soldering, 10sec)	-----	$260^\circ C$

\* Stresses beyond those listed under "absolute maximum ratings" may cause permanent damage to the device. These are stress ratings only, and function operation of the device at these or any other conditions beyond those indicated under "recommended operating conditions" is not implied. Exposure to absolute-maximum-rated conditions for extended periods may affect device reliability.

## Electrical Characteristics

(VIN=5V, TA=25°C, unless otherwise noted.)

Symbol	Parameter	Test Conditions	Min	Typ	Max	Unit
VIN	Input Voltage		2.5		9.0	V
VOUT	Output Voltage	VIN=VOUT+1V, IOUT=30mA	VOUT-0.035	VOUT	VOUT+0.035	V
IMAX	Output Current (*1)	VOUT+1V ≤ VIN ≤ 9V	300			mA
VDROP	Dropout Voltage	IOUT=300mA		400	480	mV
ΔVLINE	Line Regulation	VOUT+0.5V ≤ VIN ≤ 9V, IOUT=30mA		0.2	0.3	%/V
ΔVLOAD	Load Regulation	VIN=VOUT+1V, 10μA ≤ IOUT ≤ 100mA		0.02	0.03	%/mA
IQ	Ground Pin Current	VIN=+5V, ON/OFF Pin=ON, No Load		40	60	μA
		VIN=+9V, ON/OFF Pin=ON, No Load		60	100	μA
ISD	Shutdown Current	VIN=VOUT+1V, EN Pin=OFF, No Load		0.1	1.0	μA
VIH	EN Pin Input Voltage "H"	(see note *2)	2.0			V
VIL	EN Pin Input Voltage "L"	(see note *2)			0.5	V
IEN	EN Pin Leakage Current				0.1	μA
ISC	Short Current Limit			260	300	mA
PSRR	Ripple Rejection	VIN=VOUT+1V, F=100Hz, Vripple=1Vp-p, IOUT=30mA		60		dB
TSD	Thermal Shutdown Temperature			155		°C
THYS	Thermal Shutdown Hysteresis			20		°C
θJA	Thermal Resistance	SOT-23-5			250	°C/W
		SOT-89-5			180	°C/W

Note :

(\*1) Measured using a double sided board with 1" x 2" square inches of copper area connected to the GND pins for "heat spreading".

(\*2) EN pin input voltage must be always less than or equal to input voltage.

### Typical Operating Characteristics

(C<sub>IN</sub>=1μF, C<sub>OUT</sub>=3.3μF, T<sub>A</sub>=+25°C, unless otherwise noted.)

**OUTPUT VOLTAGE vs. INPUT VOLTAGE**

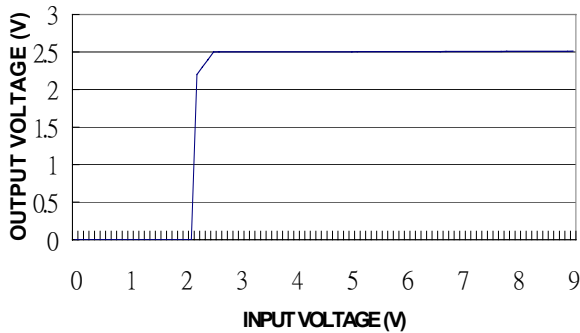

\*EX : Model FS8853A-33CA, I<sub>load</sub> = 0

**GROUND CURRENT vs. AMBIENT TEMPERATURE**

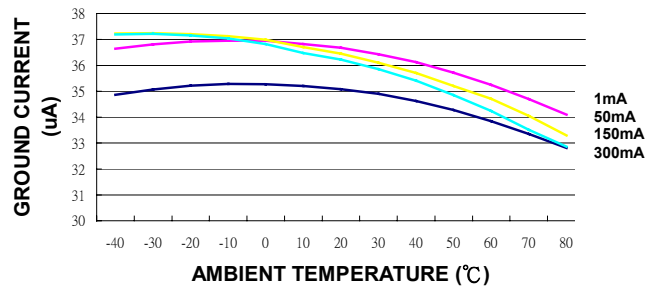

**DROPOUT VOLTAGE vs. LOAD CURRENT**

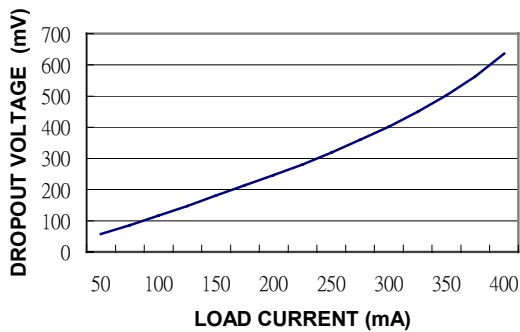

**R<sub>on</sub> vs. OUTPUT CURRENT**

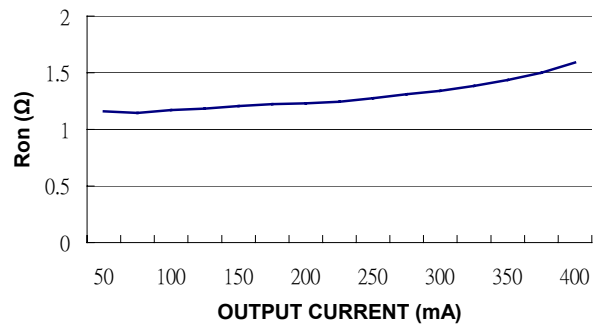

**POWER SUPPLY REJECTION RATIO vs. FREQUENCY**

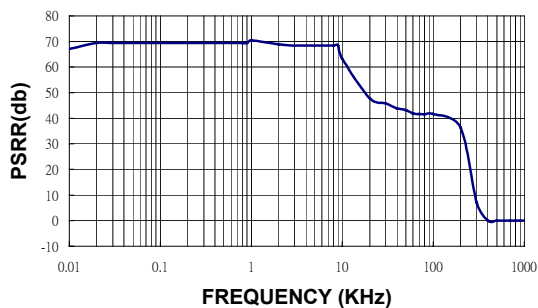

**GROUND CURRENT vs. INPUT VOLTAGE**

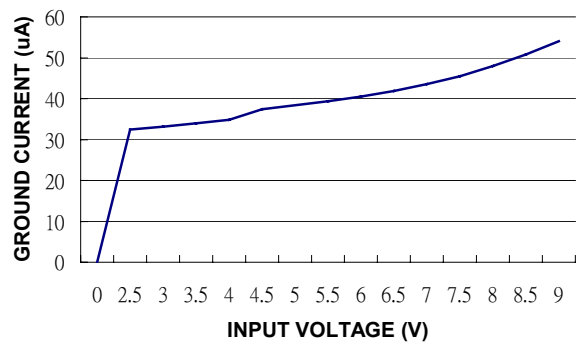

OUTPUT VOLTAGE vs. AMBIENT TEMPERATURE

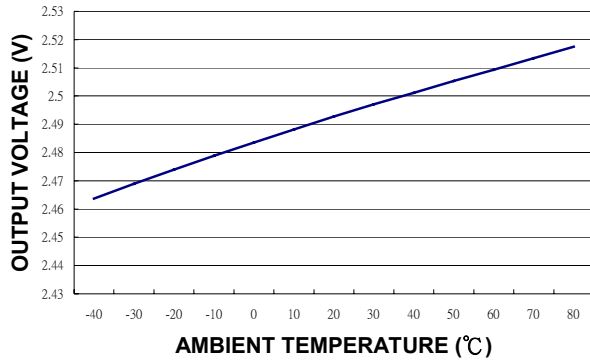

GROUND PIN CURRENT vs. INPUT VOLTAGE

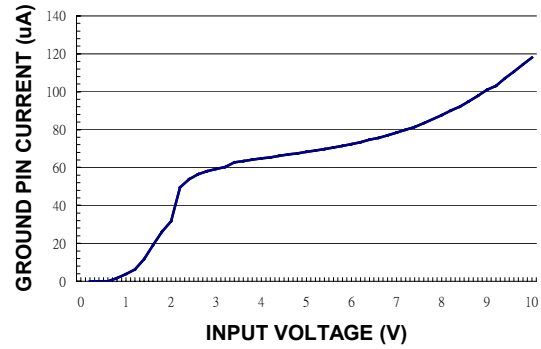

LINE TRANSIENT (I<sub>OUT</sub>=0mA)

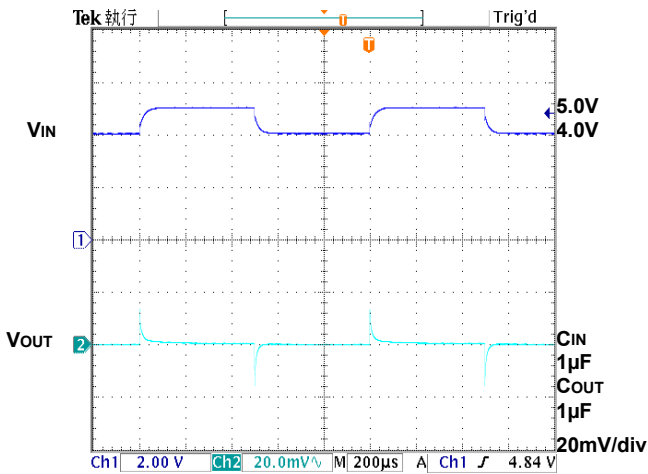

LINE TRANSIENT (I<sub>OUT</sub>=10mA)

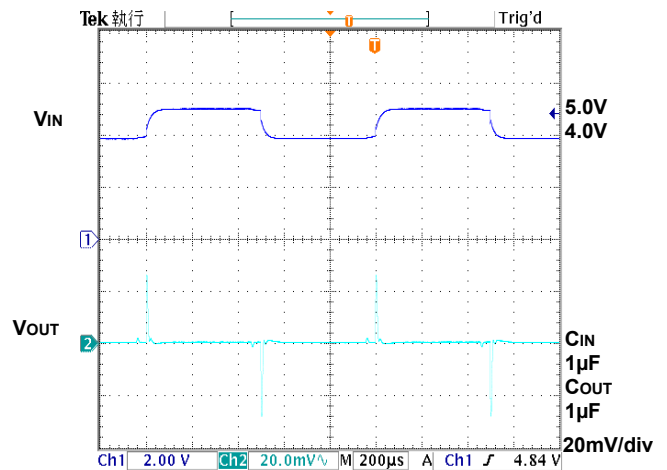

LINE TRANSIENT (I<sub>OUT</sub>=100mA)

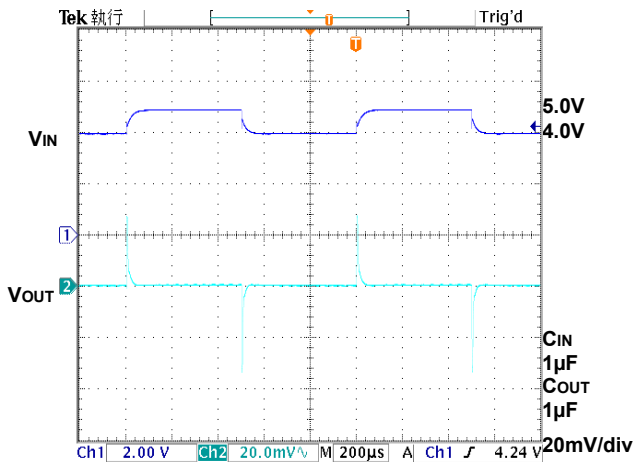

LINE TRANSIENT (I<sub>OUT</sub>=300mA)

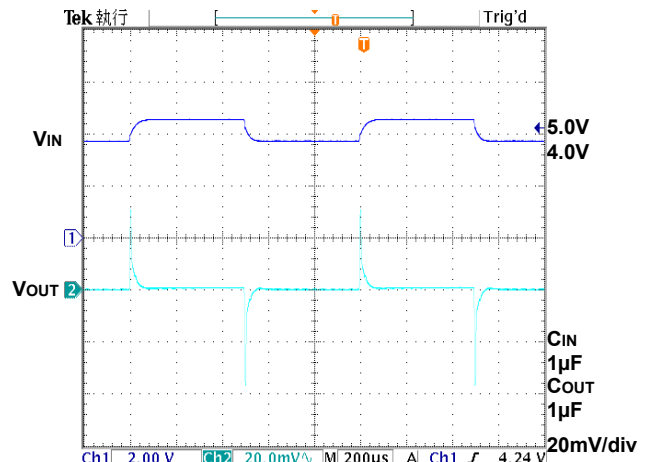

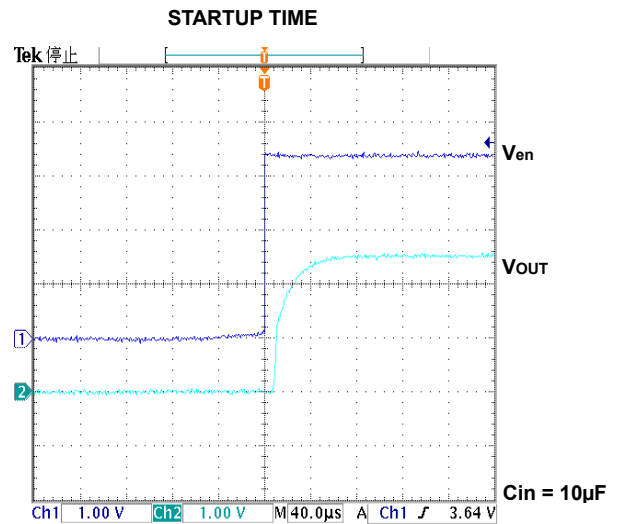
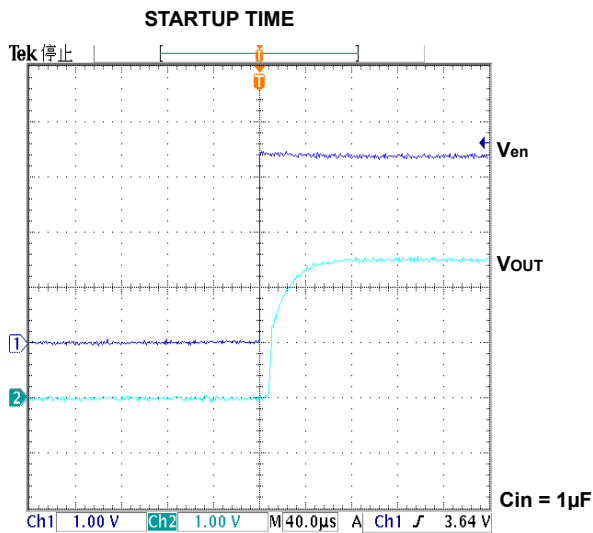
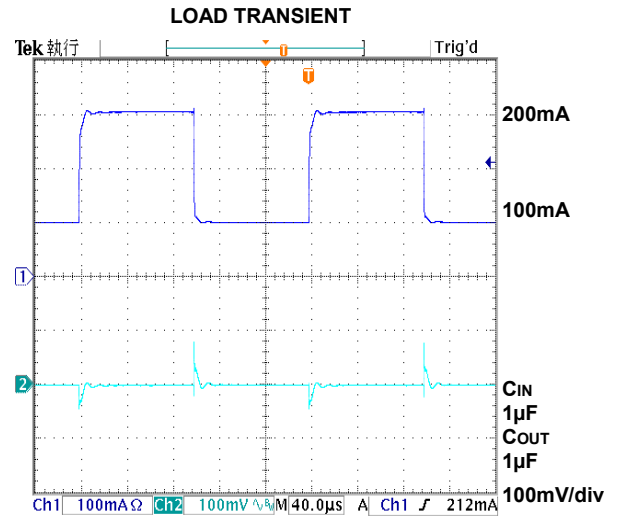
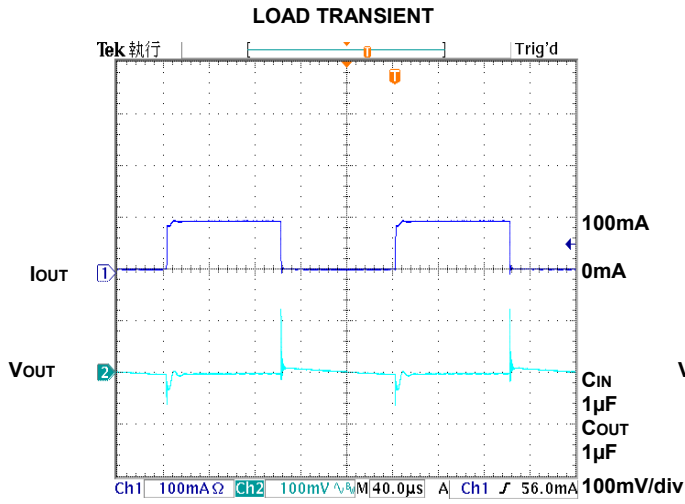



### Detail Description

The FS8853A is a low-dropout linear regulator. The device provides preset 2.5V, 2.85V and 3.3V output voltages for output current up to 300mA. Other mask options for special output voltages from 1.3V to 5.0V with 100mV increment are also available. As illustrated in function block diagram, it consists of a 1.25V reference, error amplifier, a P-channel pass transistor, an ON/OFF control logic, and an internal feedback voltage divider.

The 1.25V bandgap reference is connected to the error amplifier, which compares this reference with the feedback voltage and amplifies the voltage difference. If the feedback voltage is lower than the reference voltage, the pass-transistor gate is pulled lower, which allows more current to pass to the output pin and increases the output voltage. If the feedback voltage is too high, the pass-transistor gate is pulled up to decrease the output voltage.

The output voltage is feed back through an internal resistive divider connected to OUT pin. Additional blocks include an output current limiter, thermal sensor, and shutdown logic.

#### Internal P-channel Pass Transistor

The FS8853A features a P-channel MOSFET pass transistor. Unlike similar designs using PNP pass transistors, P-channel MOSFETs require no base drive, which reduces quiescent current. PNP-based regulators also waste considerable current in dropout when the pass transistor saturates, and use high base-drive currents under large loads. The FS8853A does not suffer from these problems and consumes only 40 $\mu$ A (Typ.) of current consumption under heavy loads as well as in dropout conditions.

#### Enable Function

EN pin starts and stops the regulator. When the EN pin is switched to the power off level, the operation of all internal circuit stops, the build-in P-channel MOSFET output transistor between pins VIN and VOUT is switched off, allowing current consumption to be drastically reduced. The VOUT pin enters the GND level due to the several M $\Omega$

resistance of the feedback voltage divider between VOUT and GND pins.

#### Output Voltage Selection

The FS8853A output voltage is preset at an internally trimmed voltage 2.5V, 2.85V or 3.3V. The output voltage also can be mask-optional from 1.5V to 5.0V with 100mV increment by special order. The first two digits of part number suffix identify the output voltage (see [Ordering Information](#)). For example, the FS8853A-33CA has a preset 3.3V output voltage.

#### Current Limit

The FS8853A also includes a fold back current limiter. It monitors and controls the pass transistor's gate voltage, estimates the output current, and limits the output current within 0.5A.

#### Thermal Overload Protection

Thermal overload protection limits total power dissipation in the FS8853A. When the junction temperature exceeds  $T_J = +155^{\circ}\text{C}$ , a thermal sensor turns off the pass transistor, allowing the IC to cool down. The thermal sensor turns the pass transistor on again after the junction temperature cools down by  $20^{\circ}\text{C}$ , resulting in a pulsed output during continuous thermal overload conditions.

Thermal overload protection is designed to protect the FS8853A in the event of fault conditions. For continuous operation, the absolute maximum operating junction temperature rating of  $T_J = +125^{\circ}\text{C}$  should not be exceeded.

#### Operating Region and Power Dissipation

Maximum power dissipation of the FS8853A depends on the thermal resistance of the case and circuit board, the temperature difference between the die junction and ambient air, and the rate of airflow. The power dissipation across the devices is  $P = I_{OUT} \times (V_{IN} - V_{OUT})$ . The resulting maximum power dissipation is:

$$P_{MAX} = \frac{(T_J - T_A)}{\theta_{JC} + \theta_{CA}} = \frac{(T_J - T_A)}{\theta_{JA}}$$

Where (T<sub>J</sub>-T<sub>A</sub>) is the temperature difference between the FS8853A die junction and the surrounding air, θ<sub>JC</sub> is the thermal resistance of the package chosen, and θ<sub>CA</sub> is the thermal resistance through the printed circuit board, copper traces and other materials to the surrounding air. For better heat-sinking, the copper area should be equally shared between the IN, OUT, and GND pins.

The thermal resistance θ<sub>JA</sub> of FS8853A SOT-23-5 package is 250°C/W. Based on a maximum operating junction temperature 125°C with an ambient of 25°C, the maximum power dissipation will be:

$$P_{MAX} = \frac{(T_J - T_A)}{\theta_{JC} + \theta_{CA}} = \frac{(125 - 25)}{250} = 0.40W$$

Thermal characteristics were measured using a double sided board with 1" x 2" square inches of copper area connected to the GND pin for "heat spreading".

### Input-Output Voltage

A regulator's minimum input-output voltage differential, or dropout voltage, determines the lowest usable supply voltage. In battery-powered systems, this will determine the useful end-of-life battery voltage. The FS8853A uses a P-channel MOSFET pass transistor, its dropout voltage is a function of drain-to-source on-resistance (R<sub>DS(ON)</sub>) multiplied by the load current.

$$V_{DROPOUT} = V_{IN} - V_{OUT} = R_{DS(ON)} \times I_{OUT}$$

**Package Outline**

**SOT-23-5**

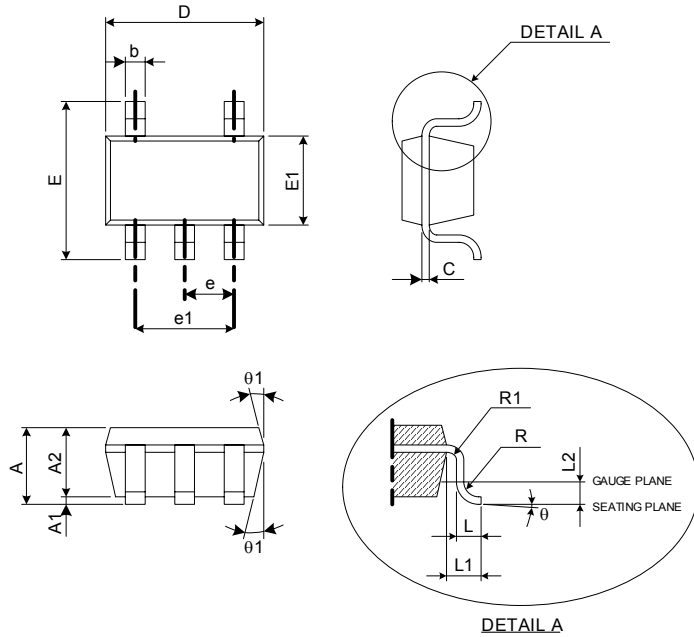

SYMBOL	DIMENSIONS IN MILLIMETERS			DIMENSIONS IN INCHES		
	MIN	TYP	MAX	MIN	TYP	MAX
A	1.00	1.10	1.30	0.039	0.043	0.051
A1	0.00	-	0.10	0.000	-	0.004
A2	0.70	0.80	0.90	0.028	0.031	0.035
b	0.35	0.40	0.50	0.014	0.016	0.020
C	0.12	0.15	0.20	0.005	0.006	0.008
D	2.70	2.90	3.10	0.106	0.114	0.122
E	2.60	2.80	3.00	0.102	0.110	0.118
E1	1.50	1.60	1.70	0.059	0.063	0.067
e	0.95 BSC.			0.037 BSC.		
e1	1.90 BSC.			0.075 BSC.		
L	0.37	0.45	0.60	0.015	0.018	0.024
L1	0.60 REF.			0.027 REF.		
L2	0.25 BSC.			0.010 BSC.		
R	0.10	-	-	0.004	-	-
R1	0.10	-	0.25	0.004	-	0.010
θ	1°	5°	9°	1°	5°	9°
θ1	5°	10°	15°	5°	10°	15°

**SOT-89-5**

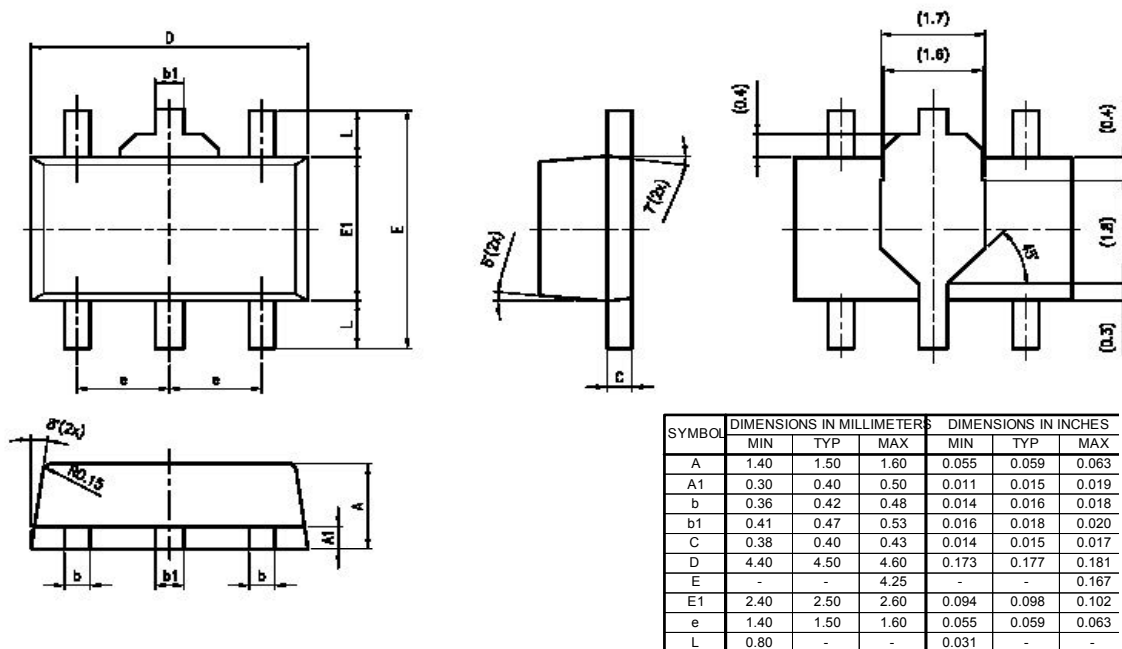

SYMBOL	DIMENSIONS IN MILLIMETERS			DIMENSIONS IN INCHES		
	MIN	TYP	MAX	MIN	TYP	MAX
A	1.40	1.50	1.60	0.055	0.059	0.063
A1	0.30	0.40	0.50	0.011	0.015	0.019
b	0.36	0.42	0.48	0.014	0.016	0.018
b1	0.41	0.47	0.53	0.016	0.018	0.020
C	0.38	0.40	0.43	0.014	0.015	0.017
D	4.40	4.50	4.60	0.173	0.177	0.181
E	-	-	4.25	-	-	0.167
E1	2.40	2.50	2.60	0.094	0.098	0.102
e	1.40	1.50	1.60	0.055	0.059	0.063
L	0.80	-	-	0.031	-	-