

Datasheet

# FS9952\_LP1

2,000 counts auto range DMM IC

FSC  
Properties  
For Reference Only

**Fortune Semiconductor Corporation**

富晶電子股份有限公司

28F., No.27, Sec. 2, Zhongzheng E. Rd.,  
Danshui Town, Taipei County 251, Taiwan

Tel. : 886-2-28094742

Fax : 886-2-28094874

www.ic-fortune.com

FSC's  
Properties  
For Reference Only

This manual contains new product information. **Fortune Semiconductor Corporation** reserves the rights to modify the product specification without further notice. No liability is assumed by **Fortune Semiconductor Corporation** as a result of the use of this product. No rights under any patent accompany the sale of the product.

## NOTICE



1. For the best use of FS9952\_LP1, please read this data sheet carefully.
2. All application schematics in the data sheet and all component specifications in the diagram are for reference only. The actual application for the schematic forms, component specifications and parameters depend on the actual situations to ensure that it can reach the requirement of design.
3. When use this product to measure the meter, it should be take care of the protection for over-voltage and over-current on input ends, lest the product and the meter causes damaged under over-voltage and over-current.
4. "Auto Power Off" of the product is a sleep status. In sleep status, the system still consumes little current (less than 1 $\mu$ A). It is better to cut off the power if not use for a long time.
5. FS9952\_LP1 is a high accuracy and multifunctional ADC with microprocessor. When apply the product, the anti-interfere problem should be considered during the PCB design and components layout to reduce external and internal interferences and get the best effect.
6. This version is updated in August 2006. It may take a change for some parameters and schematics according to the improvement and promotion of the product. If so, it will not be noted actively. For any question, please contact our company directly.

## Contents

---

1. INTRODUCTION.....	5
2. FEATURES.....	5
3. USER DEVELOPMENT FUNCTION.....	5
4. MEASURABLE MODES.....	6
5. APPLICATION FIELD.....	6
6. BLOCK DIAGRAM.....	7
7. PIN DIAGRAM.....	7
8. PIN DESCRIPTION.....	8
9. DICE PAD LAYOUT & PAD COORDINATE.....	10
10. TECHNICAL SPECIFICATION (VDD=3V, TA=25°C).....	12
11. MEASUREMENT MODE SELECT.....	13
12. KEYS DEFINITION.....	14
13. OTHER FUNCTIONS.....	15
14. LCD DISPLAY.....	16
15. APPLICATION DESCRIPTION.....	18
16. PACKAGE OUTLINE.....	30
17. ORDERING INFORMATION.....	30
18. REVISION HISTORY.....	31

## 1. Introduction

FS9952\_LP1 is a high performance, low power consumption and 3½ digits (1999 Counts) Analog to Digital Converter that built-in the microprocessor (ADC+MCU). It includes the 8 bits microprocessor, low noise and high stability OPAMP, AC rectifier OPAMP, voltage promotion and regulated voltage power, high regulated bandgap, auto measurement switch and function control circuit, buzzer driver circuit, clock oscillation circuit, backlight display control/driver circuit, LCD display driver circuit and so on.

With the microprocessor, FS9952\_LP1 can do the logic function control when goes through the I/O ports. By using the codes of MEA1~MEA4 pins, it can assemble various measurement functions, as well as construct fully auto measurement meter and fully manual measurement meter through the code settings. For the settings of Range, Select, Manual Hold, Max Hold, BLCTR and Power ON/OFF keys, you can act the measurement mode select, function switch, reading hold, backlight display, power on/off and so on functions by triggering these keys.

FS9952\_LP1 has the AC/DC and °F/°C power on first select function that is decided by SELECT1 status. This is for the convenience of user to enter the required measurement mode during power on.

With regard to the auto power off function, when there is no action within 15 minutes on the switch or keys of the meter, the system will enter the sleep mode automatically to save the power. If it is not necessary to use the auto power off function in the process of using the meter, it can be cancelled during using.

FS9952\_LP1 is made by large integrated circuit technology so that rise greatly up the reliability of the product, and make the design be simple and the volume be small. With small operating voltage and low power consumption, it is convenient to use the power supply of battery, especially suitable for the use on the palm mode meter.

FS9952\_LP1 is truly a microprocessor-embedded and multifunctional measuring ADC so that just less external components added, it can be a high accuracy, lots functions and low cost measuring meter.

## 2. Features

- 2.1 Max. Display: 1999.
- 2.2 Conversion Rate: 3 times/sec.
- 2.3 Measurement Modes: Fully Auto Measurement/Fully Manual Measurement.
- 2.4 The Negative Indication: Auto.
- 2.5 Temperature Measurement (°C) and (°F): Switch by "SELECT" key.
- 2.6 Power Voltage Range: 2.4V-3.6V.
- 2.7 Chip Power Consumption: ≤6mW .
- 2.8 Low Battery Warning: Approx. 2.4V.
- 2.9 Buzzer Driver Circuit (Frequency is about 2.7kHz).
- 2.10 Embedded OPAMP for AC/DC conversion.
- 2.11 Function Keys: Range / Manual Hold /Max Hold/ Select / BLCTR.
- 2.12 Peak Value Hold Function. Apply to Clinch Meter and so on field.
- 2.13 Unit Symbol and Backlight Display.
- 2.14 Auto Power-off (can be cancelled in using).

## 3. User Development Function

FS9952\_LP1 is a microprocessor-embedded ADC with the development system. Users can self-define the functions of the meter according to their needs, as well as compose and revise the software for new development to make it has different functions and style to suit the applications of themselves.

#### 4. Measurable Modes

- 4.1 DC Voltage: 199.9mV, 1.999V, 19.99V, 199.9V, 1000V.
- 4.2 AC Voltage: 199.9mV, 1.999V, 19.99V, 199.9V, 1000V.
- 4.3 DC Current: 199.9 $\mu$ A / 1999 $\mu$ A; 19.99mA / 199.9mA; 1.999A / 19.999A; 199.9A / 1999A.
- 4.4 AC Current: 199.9 $\mu$ A / 1999 $\mu$ A; 19.99mA / 199.9mA; 1.999A / 19.999A; 199.9A / 1999A.
- 4.5 Resistance: 199.9 $\Omega$ , 1.999k $\Omega$ , 19.99k $\Omega$ , 199.9k $\Omega$ , 1.999M $\Omega$ , 19.99M $\Omega$ .
- 4.6 Diode: 0V-1.5 V.
- 4.7 Short Circuit Test: Sound when lower than 50 $\Omega$ .
- 4.8 Triode hFE: 0-1999.
- 4.9 Temperature Measurement:  $^{\circ}$ C or  $^{\circ}$ F.

#### 5. Application Field

- 5.1 Auto Measurement Palm Digital Multimeter.
- 5.2 Auto Measurement Card Digital Multimeter.
- 5.3 Auto Measurement Pen Digital Multimeter.
- 5.4 Auto Measurement Clinch Meter (Hook Meter, Clamp Meter, etc.).
- 5.5 Number Panel Meter.

6. Block Diagram

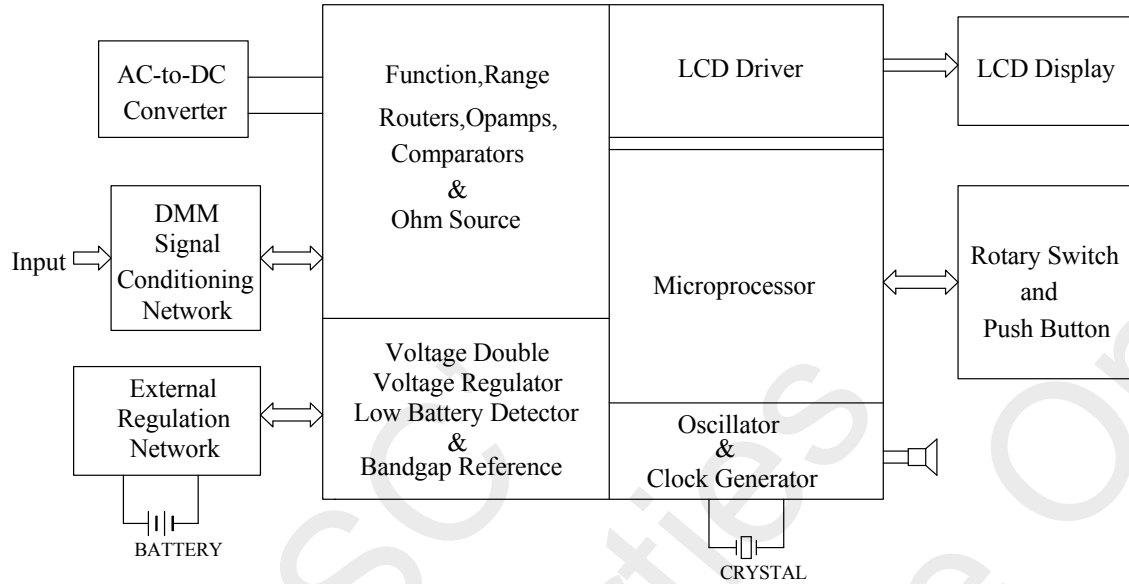

Diagram 1 Block Diagram

7. Pin Diagram

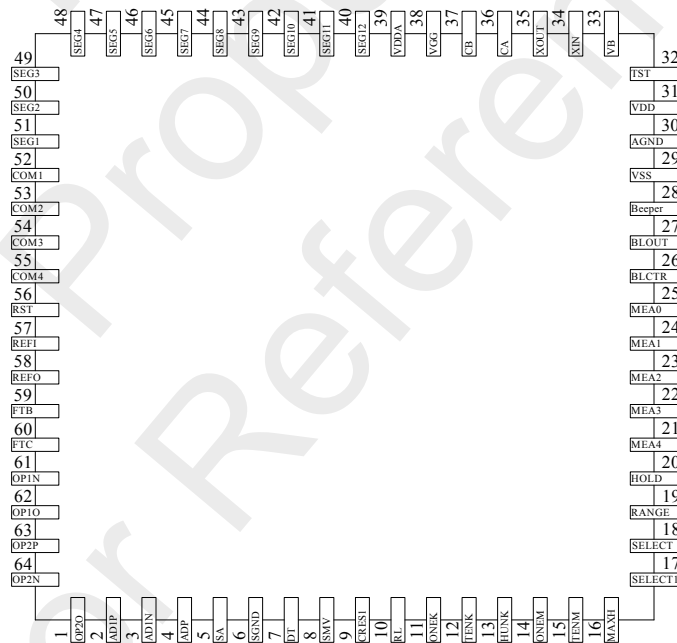

Diagram 2 64PIN Package

**8. Pin Description**

No	Symbol	I/O	Description
1	OP2O	O	The Negative Input of DC/AC Converter Operation Amplifier
2	AD1P	I	ADC Positive Input of AC Measurement
3	AD1N	I	ADC Negative Input of AC Measurement
4	ADP	I	Additional ADC Positive Input
5	SA	I	ADC Input of Current Measurement
6	SGND	I	ADC Negative Input of Analog Ground Connection
7	DT	I/O	Connecting Point of Voltage Division Resistance of Diode Measurement
8	SMV	I	High Resistance Voltage Input / ADC Positive Input of Resistance Measurement / Connecting Point of Voltage Division Resistance of Diode Measurement
9	CRES1	I/O	Wave Filter Capacitance Connecting Point of Measuring Point of Resistance Measurement
10	RL	I	The Negative Input of Voltage Reference of Resistance Measurement
11	ONEK	I/O	Connecting Point of Voltage Division Resistance 1.001KΩ of Voltage and Resistance Measurement
12	TENK	I/O	Connecting Point of Voltage Division Resistance 10.010KΩ of Voltage and Resistance Measurement
13	HUNK	I/O	Connecting Point of Voltage Division Resistance 101.010KΩ of Voltage and Resistance Measurement
14	ONEM	I/O	Connecting Point of Voltage Division Resistance 1.111MΩ of Voltage and Resistance Measurement
15	TENM	I/O	Connecting Point of Voltage Division Resistance 10.000MΩ of Voltage and Resistance Measurement
16	MAXH	I	Hold Maximum Reading
17	SELECT1	I	AC/DC Prior Select
18	SELECT	I	Measurement Function Select
19	RANGE	I	Auto/Manual Switch Select
20	HOLD	I	Hold Reading
21	MEA4	I	Measurement Function Select
22	MEA3	I	Measurement Function Select
23	MEA2	I	Measurement Function Select
24	MEA1	I	Measurement Function Select
25	MEA0	I	Measurement Function Select
26	BLCTR	I	Backlight Driver Control
27	BLOUT	O	Backlight Output
28	BEEPER	O	Buzzer Driver Output
29	VSS	I	The Negative of Power Source
30	AGND	I	Analog Signal Ground Connection
31	VDD	I	The Positive of Power Source
32	TST	I	Testing Pin
33	VB	I	Bias Current Input
34	XIN	I	Oscillator Connecting Point
35	XOUT	O	Oscillator Connecting Point
36	CA	I/O	The Positive Connecting Point of Double Voltage Capacitance
37	CB	I/O	The Negative Connecting Point of Double Voltage Capacitance
38	VGG	I/O	Double Voltage Power Output
39	VDDA	I/O	Regulated Power Output/Analog Circuit Power Source
40~51	SEG12~ SEG1	O	LCD Segment 12~ LCD Segment 1



52~55	COM1~ COM4	O	Backplane 1~ Backplane 4
56	RST	I	CPU Reset
57	REFI	I	ADC Based Power Input
58	REFO	O	Bandgap Output
59	FTB	I	ADC Wave Pre-Filter Positive Input
60	FTC	I/O	The Negative Terminal of ADC Wave Pre-Filter
61	OP1N	I	AC Signal Buffer Operation Amplifier Input
62	OP1O	O	AC Signal Buffer Operation Amplifier Output
63	OP2P	I	AC Signal Buffer Operation Amplifier Input
64	OP2N	I	DC/AC Converter Operation Amplifier Positive Input

FSC's  
Properties  
Only  
For Reference

9. Dice Pad Layout & Pad Coordinate

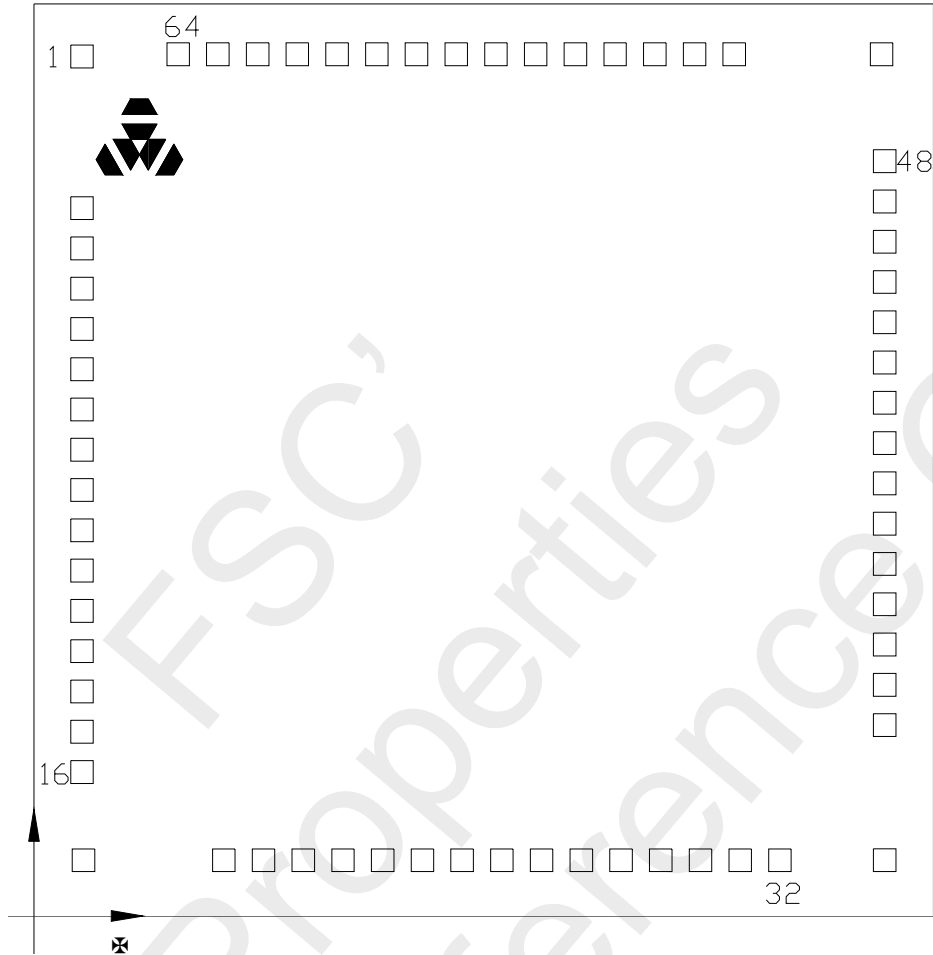

Substrate should be connected to VSS  
 Pad opening: 72µm ◦  
 Chip size: 2.344mm×2.594mm ◦

Diagram 3 64-PIN Dice

BONDING PAD LOCATION

※ FSC P/N : FS9952\_LP1  
 ※ PAD NO : 64 pads

※Package : LQFP64  
 ※Die Size : 2344×2594μm<sup>2</sup>

Pad No	Name	X[μm]	Y[μm]	Pad No	Name	X[μm]	Y[μm]
1	OP2O	86.475	72.000	33	VB	2258.825	2522.000
2	AD1P	329.825	72.000	34	XIN	2029.500	2522.000
3	AD1N	449.825	72.000	35	XOUT	1904.500	2522.000
4	ADP	569.825	72.000	36	CA	1784.500	2522.000
5	SA	689.825	72.000	37	CB	1650.150	2522.000
6	SGND	809.825	72.000	38	VGG	1530.150	2522.000
7	DT	929.825	72.000	39	VDDA	1410.150	2522.000
8	SMV	1049.825	72.000	40	SEG12	1290.150	2522.000
9	CRES1	1169.825	72.000	41	SEG11	1170.150	2522.000
10	RL	1289.825	72.000	42	SEG10	1050.150	2522.000
11	ONEK	1409.825	72.000	43	SEG9	930.150	2522.000
12	TENK	1529.825	72.000	44	SEG8	810.150	2522.000
13	HUNK	1649.825	72.000	45	SEG7	690.150	2522.000
14	ONEM	1769.825	72.000	46	SEG6	570.150	2522.000
15	TENM	1889.825	72.000	47	SEG5	450.150	2522.000
16	MAXH	2009.825	72.000	48	SEG4	330.150	2522.000
17	SELECT1	2258.825	72.000	49	SEG3	86.475	2522.000
18	SELECT	2272.025	508.875	50	SEG2	86.675	2124.800
19	RANGE	2272.025	628.875	51	SEG1	86.675	2004.800
20	HOLD	2272.025	748.875	52	COM1	86.675	1884.800
21	MEA4	2272.025	868.875	53	COM2	86.675	1764.800
22	MEA3	2272.025	988.875	54	COM3	86.675	1644.800
23	MEA2	2272.025	1108.875	55	COM4	86.675	1524.800
24	MEA1	2272.025	1228.875	56	RST	86.675	1389.400
25	MEA0	2272.025	1348.875	57	REFI	86.675	1269.400
26	BLCTR	2272.025	1468.875	58	REFO	86.675	1149.400
27	BLOUT	2272.025	1588.875	59	FTB	86.675	1029.400
28	BEEPER	2272.025	1708.875	60	FTC	86.675	909.400
29	VSS	2272.025	1828.875	61	OP1N	86.675	789.400
30	AGND	2272.025	1948.875	62	OP1O	86.675	669.400
31	VDD	2272.025	2068.875	63	OP2P	86.675	549.400
32	TST	2272.025	2188.875	64	OP2N	86.675	429.400

**10. Technical Specification (VDD=3V, Ta=25°C)**

Symbol	Parameter	Test Condition	Min	Typ	Max	Units
VDD	Recommend Operation Power Voltage		2.4		3.6	V
IDD	Supply Current	At DCV Mode		1.5	2	mA
IPO	Power-off Supply Current	At Power Off			10	μA
VIH	Digital Input High Voltage		VDD-0.5			V
VIL	Digital Input Low Voltage				0.5	V
Ipu	Pull up Current	Vin=0		5	10	μA
AGND	Analog Ground Voltage		VDD/2-3%	VDD/2	VDD/2+3%	V
VDDA	Analog Power		3.4	3.7	4	V
VBAND	Build in Reference Voltage	Relative AGND Voltage	1.1	1.25	1.1	V
	Build in Reference Voltage Output Voltage Coefficient	VDD=2.4~3.6	-2000		2000	Digits
REFI	Recommend Reference input Voltage	Relative AGND Voltage		0.44		V
VBATT	Low Battery Detector Voltage		2.25	2.4	2.55	V
FLCD	LCD Frame Frequency			32		Hz
VLCD	LCD PK-PK Driver Voltage		2.8	3	3.2	V
FBEEP	Beeper Frequency			2.7		kHz
	Zero Input Reading	DC ADP×1 Input=0V	-0.001	0	0.001	Digits
		Linearity (Max. Deviation From Best Straight Line Fit)	DC ADP×1 Input, Full Scale±2400mV	-1	0	1
	AC Measurement Bandwidth Error	AC ADP×1 Input 240mVrms 20Hz~1KHz			0.2	
		RCC	Continuity Check Value	10		60
	ADC Measurement O.L Display Count			2000		Digits
	Auto range Up Count			2000		Digits
	Auto range Down Count			360		Digits

**11. Measurement Mode Select**

11.1 Measurement Mode Select (Code table of Auto Measurement and Fully Manual Measurement, MEA0~MEA4: Not connected is “1”; Connect to VSS is “0”):

M E A4	M E A3	M E A2	M E A1	M E A0	Function	SELECT1 Prior Function		Range	Hold	Jumper	
						1	0				
1	1	1	1	1	DCV			●	●	J7	
1	1	1	1	0	DCV/ACV	ACV/DCV	DCV/ACV	●	●	J7	
1	1	1	0	1	Ohm/Diode /continuity	Ohm/Diode /continuity		Ohm	Ohm	J6 , J8,J10	
1	1	0	1	1	ACV			●	●	J7	
1	0	1	1	1	Ohm			●	●	J6 , J8,J10	
1	1	1	0	0	200μA/2000μA	ACA/DCA	DCA/ACA	●	●	J5 ,	
1	0	0	1	1	20mA/200mA			●	●	J4 ,	
1	1	0	0	1	2A/20A			●	●		
1	0	1	1	0	200A/2000A			●	●		
1	1	0	1	0	Diode/Continuity	Diode/Continuity				J6 , J8,J10	
1	0	1	0	1	hFE				●	J2	
1	1	0	0	0	Temp.	°C/°F	°F/°C		●	J1,J3,J9	
1	0	1	0	0	Refer to Table 9.2				●		
1	0	0	1	0						●	
1	0	0	0	1						●	
0	1	1	1	1	200mv	ACV/DCV	DC/AC		●	J7	
0	1	1	1	0	2V				●	J7	
0	1	1	0	1	20V				●	J7	
0	1	0	1	1	200V				●	J7	
0	0	1	1	1	1000V				●	J7	
0	1	1	0	0	200Ω				●	J6 , J8,J10	
0	0	0	1	1	2kΩ				●	J6 , J8,J10	
0	1	0	0	1	20kΩ				●	J6 , J8,J10	
0	0	1	1	0	200kΩ				●	J6 , J8,J10	
0	1	0	1	0	2MΩ				●	J6 , J8,J10	
0	0	1	0	1	20MΩ		●	J6 , J8,J10			

Note: In “Jumper” column, JX means the JX of the measurement is connected in the common use circuitry of Diagram 1.

11.2 Self-defined Symbols and Decimal Location (MEA0~MEA4: Not connected is “1”; Connect to VSS is “0”)

MEA4	MEA3	MEA2	MEA1	MEA0	Range of Input Voltage	Input Channel	Decimal Location	Symbol Location	Symbol
1	0	1	0	0			2000	COM2, SEG11	
1	0	0	1	0	±200mV	ADP	20.00	COM2, SEG12	User-Defined
1	0	0	0	1			200.0	COM1, SEG12	

## 12. Keys Definition

- 12.1 Range (Auto/Manual Measurement Switch)  
Range (S9) key is the auto/manual measurement key that acts with trigger. Power-on default is auto measurement, and press one time to switch to the manual measurement. In manual measurement mode, the system will jump up one mode for each press until the highest mode, then return to the lowest mode as a loop. If press the key over 2 seconds, the system will switch back to auto measurement status.
- 12.2 Manual Hold (Reading Hold)  
Hold (S8) key is the reading hold key that acts with trigger. The function is to hold the display of reading. To press the key, the display value will be locked and keep unchanged. To press the key again, the locked status will be erased and enter the normal measurement status.  
**Note: After auto power-off, if pressing HOLD key to wake up the system, the auto power-off function will be cancelled.**
- 12.3 MAXH (Maximum Value Hold)  
MAX H (S11) is the maximum value hold key that acts with trigger. After pressing the key, A/D will keep working, and the display value are always updated and kept the maximum value. (The actual gained value is not the peak value, but maximum value. For the peak value, it is necessary to add up the peak oscilloscope in external circuit).
- 12.4 BLCTR (Backlight Control)  
BLCTR (S7) is the backlight control key that acts with trigger. When press the BLCTR key over approximately 2 seconds, the backlight will be on. To press the BLCTR key again over 2 seconds, the backlight will be off.
- 12.5 Select (Function Switch)  
Select (S10) is the function select key that acts with trigger. Use the key as the switch of DC / AC, Ohm / Diode / Beeper and °C / °F.
- 12.6 RST (Reset Key)  
RST key is the reset key that acts with trigger.

### 13. Other Functions

#### 13.1 Auto Power Off

In the process of measuring, no matter the function key or switch, if there is no any action on them within 15 minutes, the meter will be "Auto Power Off" (Sleep Mode) to save the power. To cancel the auto power off function, it is simply to press and hold the Manual Hold key to turn the system on, and then the auto power off function will be cancelled.

In auto power off status to press the function keys or switches, the meter will be "Auto Power On" (Operating Mode).

**Note: In AC mode (MEAS: 11110) and auto power off, DC mode (MEAS: 11111) cannot be waked up singly.**

**In sleep mode, the auto function will be cancelled if pressing Manual Hold key to turn the system on.**

#### 13.2 Buzzer

When press any key or turn any function switch, the buzzer will raise one "beep" sound (approx. 0.25 second ~1 second). When measuring AC Voltage>750V, DC Voltage>1000V, AC/DC mA Current>2000uA, AC/DC  $\mu$ A Current>200.0mA, AC/DC Large Current>10A, the buzzer will keep sounding as the overload warning. Approximate 1 minute before the system is auto power off, the buzzer will raise constantly 5 sounds to warning. Before the system is power off, the buzzer will raise 1 long sound to warning.

#### 13.3 SELECTC1 (Not connected is "1"; Connect to VSS is "0".)

If set SELECT1 to "1", the power on default status is AC or °F; if set it to "0", the power on default status is DC or °C.

#### 13.4 Backlight

The system has the backlight driver output to control the on and off of the backlight circuit. It provides the convenience to read in a dim light and worse vision. If press the BLCTR (S7) key over approx. 2 seconds, the backlight will be on to drive the backlight circuit, and to press the key again, the backlight will be off. After backlight is on, if no press on the key, it will be auto off in 15 seconds.

14. LCD Display

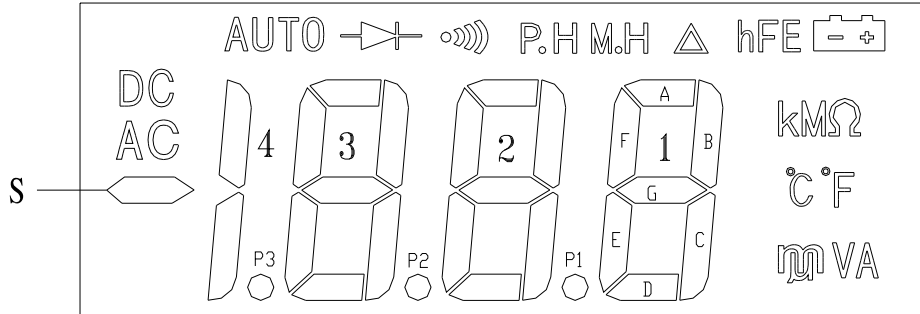

PIN	1	2	3	4	5	6	7	8	9	10	11	12	13	14	15	16
COM	COM4	COM3	COM2	COM1	SEG1	SEG2	SEG3	SEG4	SEG5	SEG6	SEG7	SEG8	SEG9	SEG10	SEG11	SEG12
COM1				COM1	DC	AUTO	A3	▶	A2	⦿	P.H	A1	M.H	△	hFE	⊞
COM2			COM2		AC	F3	G3	B3	F2	B2	F1	G1	B1	k	M	Ω
COM3		COM3			S	E3	C3	E2	G2	C2	E1	C1	°C	°F		
COM4	COM4				B4C4	P3	D3	P2	D2	P1	D1	m	μ	V	A	

- Notes: 1. Operating Voltage: 3V.  
2. Driver Method: 1/4 Duty, 1/3 Bias.

Diagram 4 LCD Display Segment Structure

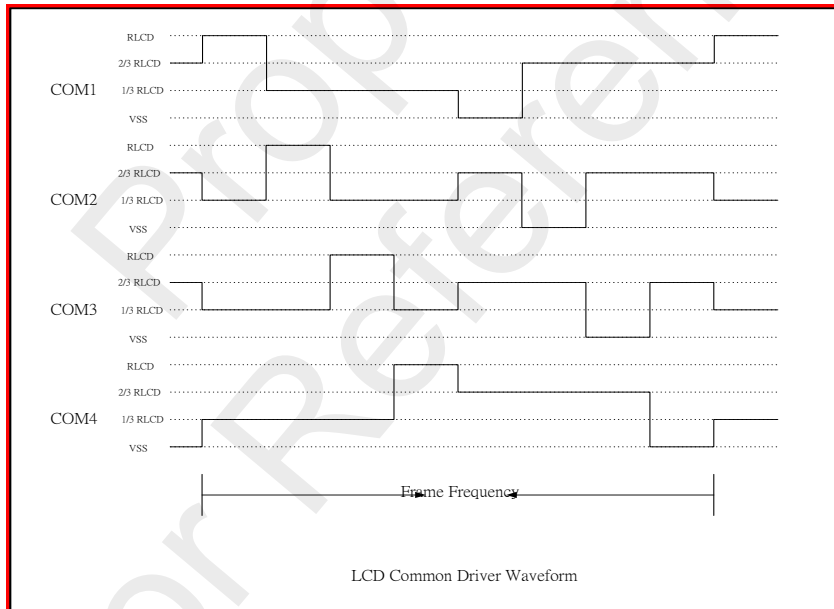





Diagram 5 LCD Display COM Waveform



FS9952 LP1 LCD Display Symbol

Symbol	Description
	Low battery
AUTO	Auto measurement
AC	AC voltage or current
DC	DC voltage or current
	DC voltage or current negative
	Diode measurement mode
	Open-short test
P.H	Maximum data hold mode
M.H	Manual data hold mode
hFE	Triode DC amplified rate
mV · V	Voltage unit
μA · mA · A	Current unit
Ω · kΩ · MΩ	Resistance unit
Hz · kHz · MHz	Frequency unit
%	Pulse signal duty percentage
°C °F	Centigrade/Fahrenheit temperature symbol

### 15. Application Description

#### 15.1 Common Use Circuitry

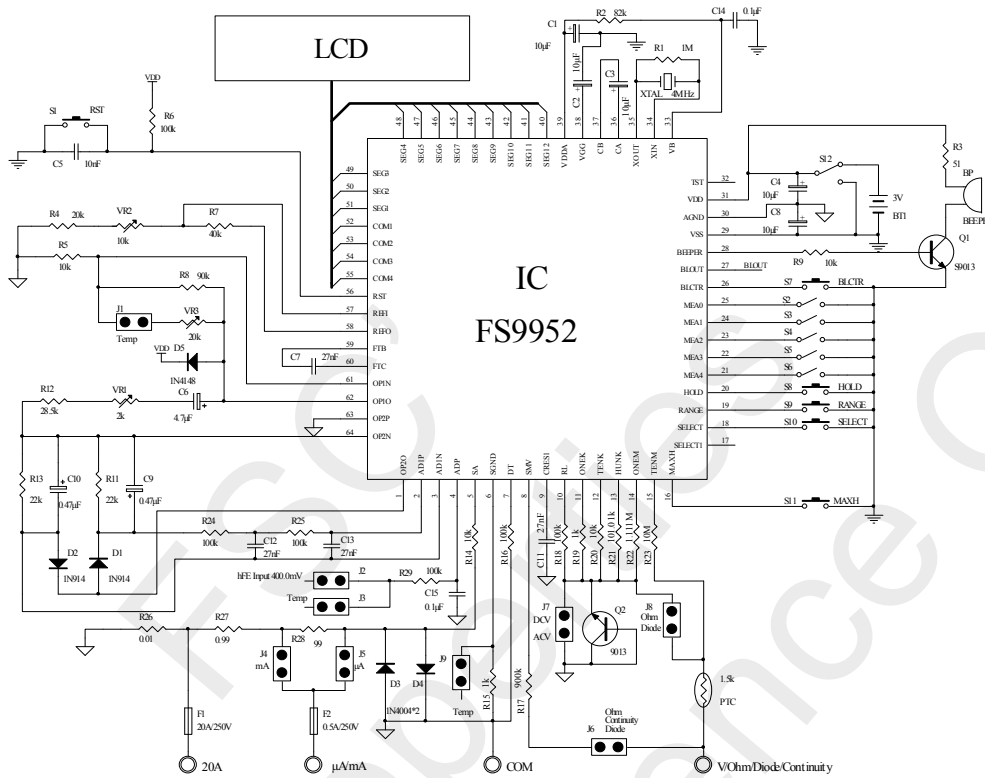





- VSS  Battery Negative Terminal and IC Negative Power Input
- VDD  Battery Positive Terminal and IC Positive Power Input
- VGG  VDD Charge Pump voltage about 2\*VDD
- VDDA  IC Analog Power about 3.9V
- AGND  Analog Common about VDD/2

Diagram 6 Common Use Circuitry

15.2 Components List of Common Use Circuitry

No.	Spec.	No.	Spec.	No.	Spec.	No.	Spec.	No.	Spec.
R1	1MΩ	R13	22kΩ	R25	100kΩ	C7	27nF	D2	1N914
R2	82kΩ	R14	10kΩ	R26	0.01Ω	C8	10μF	VR1	2kΩ
R3	51Ω	R15	1kΩ	R27	0.99Ω	C9	0.47μF	VR2	10kΩ
R4	20kΩ	R16	100kΩ	R28	99Ω	C10	0.47μF	VR3	10kΩ
R5	10kΩ	R17	900kΩ	R29	100kΩ	C11	27nF	F1	Fuse 20A
R6	100kΩ	R18	100kΩ	PTC	1.5kΩ	C12	27nF	F2	Fuse 0.5A
R7	40kΩ	R19	1kΩ	C1	10μF	C13	27nF	LCD	LCD
R8	90kΩ	R20	10kΩ	C2	10μF	C14	0.1μF	XTAL	4MHz
R9	10kΩ	R21	101.01kΩ	C3	10μF	C15	0.1μF	IC	FS9952_LP1
R10	180Ω	R22	1.111MΩ	C4	10μF	Q1	9014	Battery	1.5V×2
R11	22kΩ	R23	10MΩ	C5	10nF	Q2	9013	BP	Buzzer
R12	28.5kΩ	R24	100kΩ	C6	4.7μF	D1	1N914		

Note: The accuracy, power, pressure-proof and so on technical indications do not list in the Common Use Circuitry and components table, it depends on the actual demand for users themselves in products design.

15.3 Power System

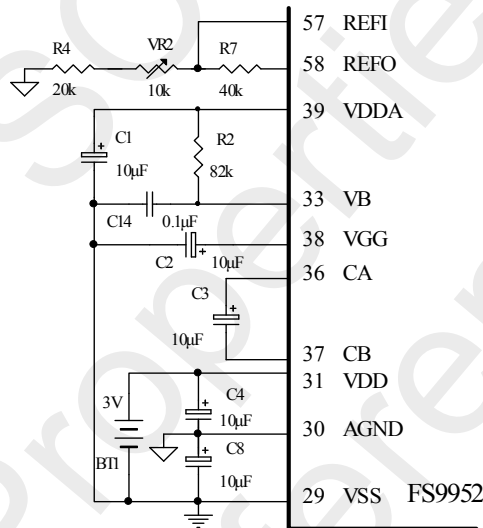

Diagram 7 Power System

The voltages of IC pins in the power system are shown as Diagram 8.

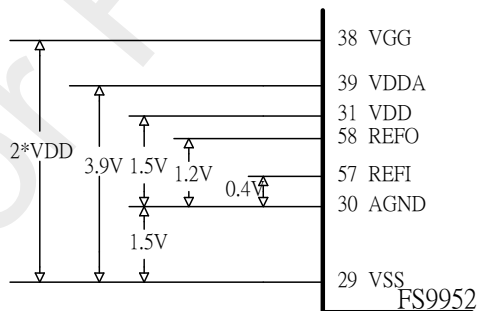

Diagram 8 Voltage of Each Point in Power System

VB is the bias current input point in IC. The increase of R4 will reduce the current consumption in IC, but the shortage of bias current will affect the input range of AC measurement.

AGND is the analog ground connection. Its potential is equal to the middle point of battery voltage. The potential of the point is generated in the IC and cannot connect to the middle point of battery.

C4 and C5 are bypath capacitance, and also to make AGND regulated to VDD and VSS. C2 is the power pump capacitance. IC makes VDD voltage pass C3 to charge/discharge so as to raise VGG to be about double voltage of VDD.

VDDA is the output voltage after the regulation of VGG in the IC. It is about 3.9V that relative to VSS.

REFO is the bandgap power source in the IC. It is about 1.2V that relative to AGND and has 100ppm/°C stability.

Oscillation Circuit

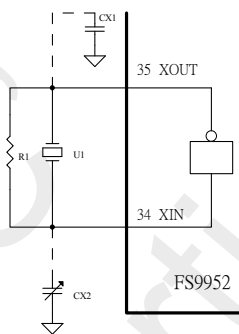

Diagram 9 Oscillation Circuit

The oscillation of FS9952\_LP1 can be quartz, but for the cost reduction, it also can be ceramic.

In the diagram, R1 is the reviser to provide the static working point; CX2 is the fine adjustment of frequency; CX1 is temperature offset. In less requirements situation, CX1 and CX2 can be unused.

15.5 Mode Switch and Function Control Circuit

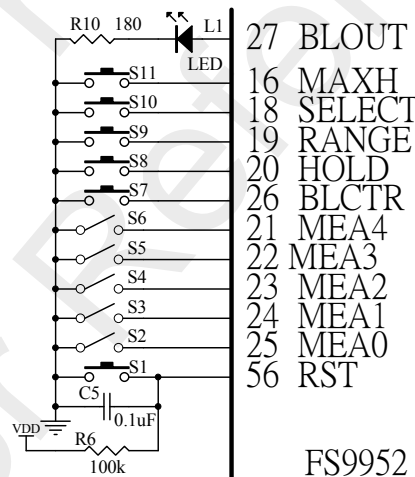

Diagram 10 Mode Switch and Function Control Circuit

S2~S6 are mode switches which are the lock switches. For their functions, please refer to 9.1.

S1 and S7~S11 are function control switches which are the trigger switches. For their functions, please refer to "Keys Definition" and "Other Functions".

15.6 Base Power Source

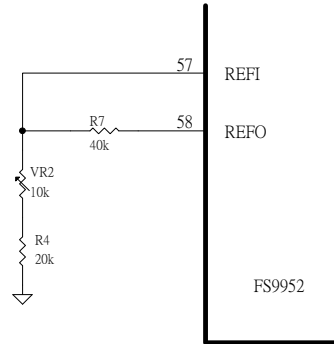

Diagram 11 The Utility of Internal Base Power Source

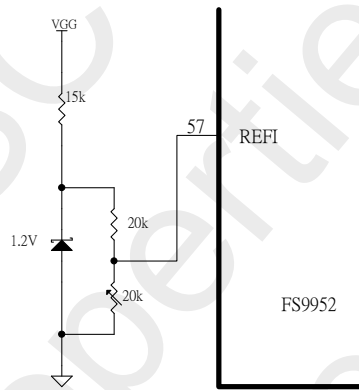

Diagram 12 The Utility of External Base Power Source

15.7 Reset Circuit

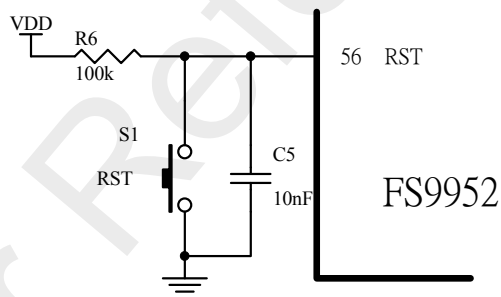

Diagram 13 Reset Keys

15.8 Buzzer Driver Circuit

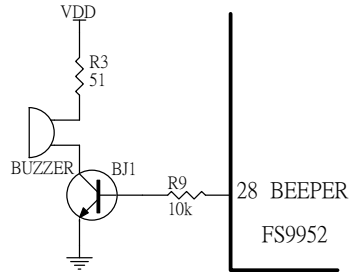

Diagram 14 Low Resistance Buzzer Connection

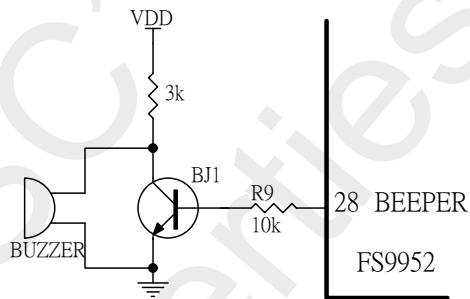

Diagram 15 High Resistance Buzzer Connection

15.9 Power Supply Circuit

The different applications of users make different power supply methods. In some measurements, the sensor requires higher voltage such as OPAMP, Hale components and so on that it is difficult to supply the power by 3V, then you can take some power supply methods as below.

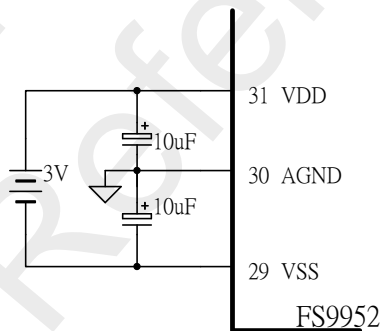

Diagram 16 3V Power Supply

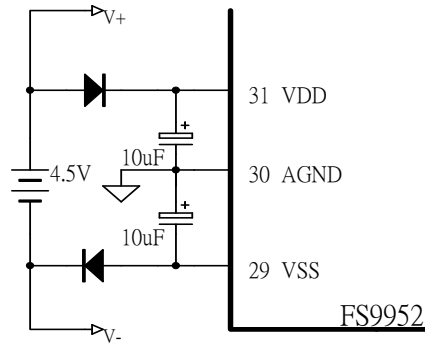

Diagram 17 4.5V Power Supply

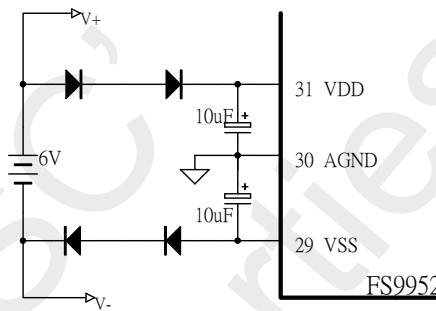

Diagram 18 6V Power Supply

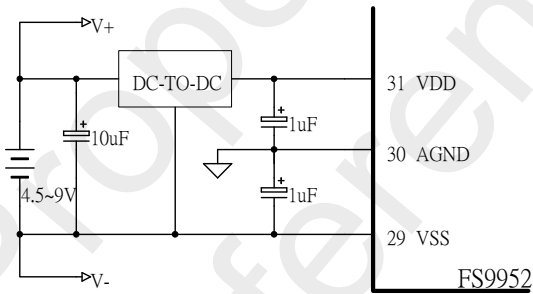

Diagram 19 4.5V~9V Power Supply

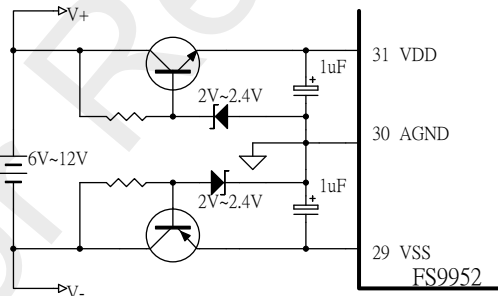

Diagram 20 6V~12V Power Supply

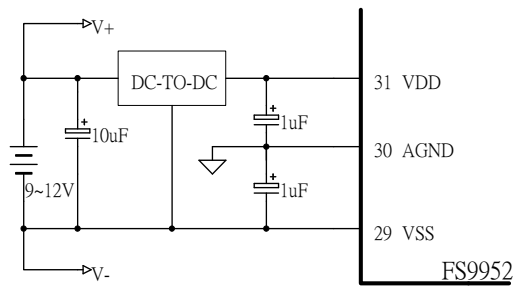

Diagram 21 9V~12V Power Supply

FSC's  
 Properties  
 For Reference Only



15.10 AC Rectification Circuit

Diagram 22 is the average rectification circuitry of FS9952\_LP1. In the circuit, AC signals enter IC through R23, and then in the process of voltage division through R23, R22, R21, R20 and R19. The divided AC signals come out from OP10 pin and enter IC through ADIP pin and ADIN pin after rectification. VR1 can adjust the signal size to be the calibration of AC measurement.

200mV mode is amplified 10 times through OP.

Diagram 23 is the peak value rectification circuitry. Diagram 24 is the true valid value rectification circuitry. The user can determine by oneself according to the need to select which rectification circuit to use.

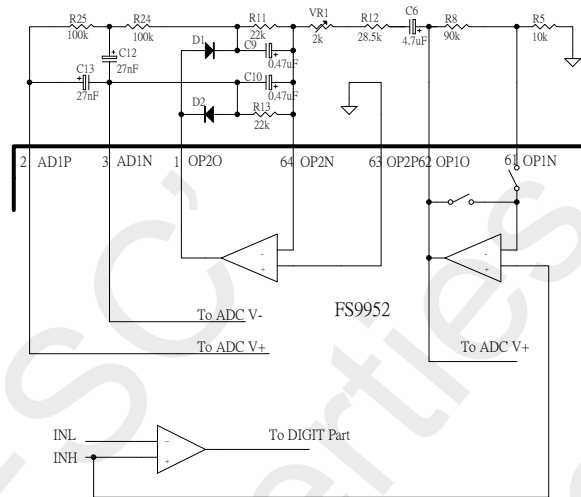

Diagram 22 Average Rectification Circuit

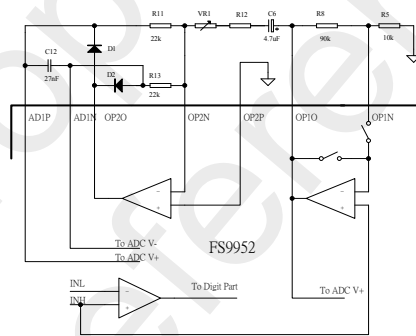

Diagram 23 Peak Value Rectification Circuit

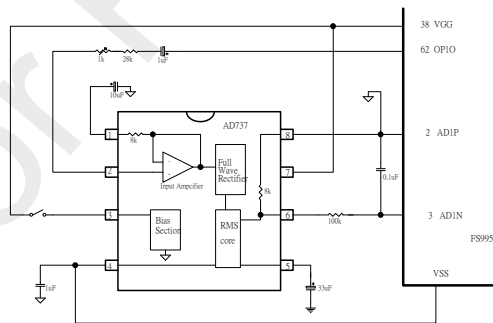

Diagram 24 True Valid Value Rectification Circuit

15.11 Voltage Measurement

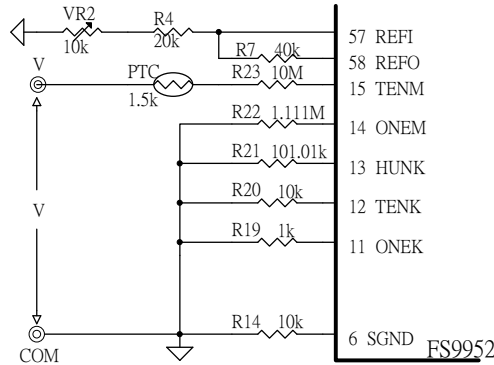

Diagram 25 Voltage Measurement

When doing the voltage measurement, the measuring voltage is input from resistance R23 and DCmV is not divided but enter IC directly; the voltages of 2V, 20V, 200V, 1000V modes are divided by R22, R21, R20, R19 and R23 to gain 1/10, 1/100, 1/1000, 1/10000 input voltages, then enter IC. To adjust the resistance value of VR2 can do the calibration of the measurement.

The voltage division diagram of voltage measurement is as below:

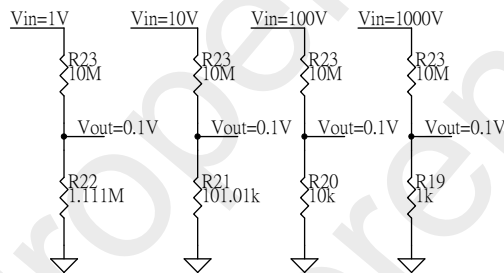

Diagram 26 Voltage Division Circuit Diagram

15.12 The formula of voltage division is:

$$V_O = V_{in} \times [R_x / (R_{23} + R_x)]$$

Rx is R22, R21, R20 or R19

Therefore, the accuracy of R19, R20, R21, R22 and R23 decide the accuracy of the measurement.

AcmV voltage enters IC through R23 and is divided by R22 and R23 to get 1/10 voltage, then is amplified 10 times to fulfill the measurement by A/D, so the accuracy of R5 and R8 is also determine the measuring accuracy of AcmV voltage.

15.12 Current Measurement

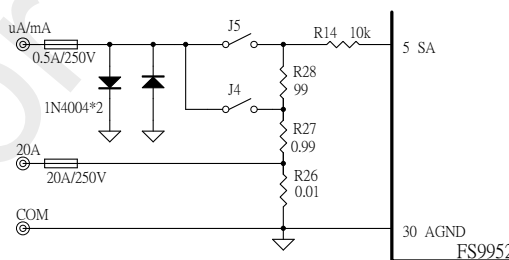

Diagram 27 Current Measurement

When doing the current measurement, the current signals enter IC through R14.

The sampling resistance of  $\mu\text{A}$  mode is  $R26+R27+R28$ , the sampling resistance of  $\text{mA}$  mode is  $R27+R26$  and the sampling resistance of  $20\text{A}$  mode is  $R26$ . They are measured respectively through the mode switch. When measuring  $\mu\text{A}$ , J4 is open, and J5 is close; when measuring  $\text{mA}$ , J14 is close, and J5 is open; when measuring the large current of  $20\text{A}$  mode, the current enter directly from  $20\text{A}$  port.

The maximum reduced voltage for  $\mu\text{A}$ ,  $\text{mA}$  and  $10\text{A}$  modes is  $0.2\text{V}$ .

These voltages are input voltage comparator to compare. If the voltage is smaller than  $20\text{mV}$ , it will be sent to 10 times amplifier to amplify, then sent to A/D converter; if the voltage is larger than  $20\text{mV}$ , the system will act the auto jump mode to jump up one mode under the control of the microprocessor, and then send directly the current signal into A/D converter.

### 15.13 Resistance Measurement

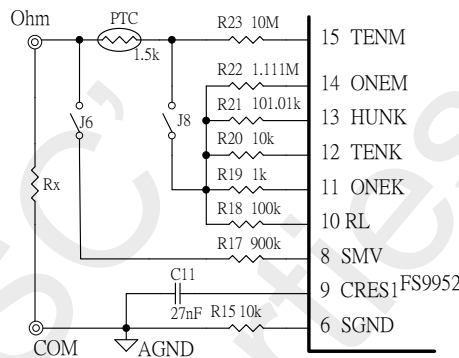

Diagram 28 Resistance Measurement

Resistance measurement refers to standard resistance, and then takes a comparison between measuring resistance and standard resistance to get the measuring resistance value. The standard resistance of  $20\text{M}\Omega$  mode is  $10\text{M}\Omega$  ( $R23$ ). The standard resistance of other modes are  $R23$  to parallel respectively with  $R22$ ,  $R21$ ,  $R20$  and  $R19$  to get  $1\text{M}\Omega$ ,  $100\text{k}\Omega$ ,  $10\text{k}\Omega$ ,  $1\text{k}\Omega$  resistance. When doing resistance measurement, internal IC will generate  $0.4\text{V}$  voltage (relative to  $\text{AGND}$ ), the voltage is output respectively to measuring resistance to compare through resistance  $R23$ ,  $R22$ ,  $R21$ ,  $R20$  and  $R19$ .  $R18$  connects to  $\text{RL}$ , which is the negative input of the voltage reference that is gotten by the standard resistance.  $J3$  and  $J5$  are mode switches. When doing resistance measurement,  $J6$  and  $J8$  are close.  $C11$  is the wave filter capacitance of measuring point in resistance measurement.

### 15.14 Diode Test

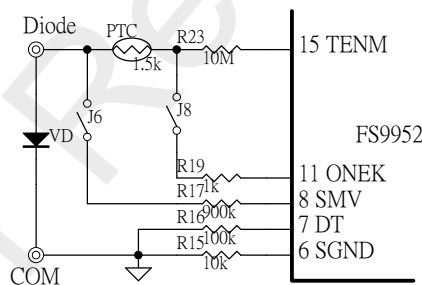

Diagram 29 Diode Measurement

Diode test generates  $1.5\text{V}$  voltage from internal IC and outputs it through  $R19$ , then adds it to the positive of diode through PTC. The positive voltage reduction  $V_D$  generated by diode is approx.  $0.5\text{V}-0.7\text{V}$ .  $V_D$  is divided by  $R17$  and  $R16$  to be  $1/10 V_D$ , then is amplified 10 times by internal OP and is delivered to A/D before displaying the  $V_D$  value.  $J6$  and  $J8$  are mode switches. When doing diode measurement,  $J6$  and  $J8$  are close.

15.15 Open-Short Test

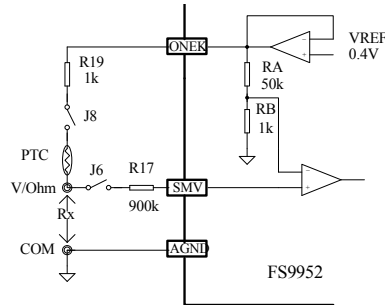

Diagram 30 Open-Short Test

When doing the open-short test, the inner of IC will generate 0.4V voltage (relative to AGND) that is output from R19 and is added to open-short measuring point through PTC. J6 and J8 are mode switches that are close during doing the open-short test. Rx gets voltage  $V_{Rx}$ , and enters IC through R17. From the diagram we know that

$$R_x = (R_{19} + PTC) / 50$$

So, the resistance value of PTC will influence the upper limit of open-short test resistance. When not connect to PTC, if R22 is 1kΩ, then the resistance of the buzzer sound is smaller than 30Ω.

15.16 AC Large Current Clamp Meter Measurement Circuit

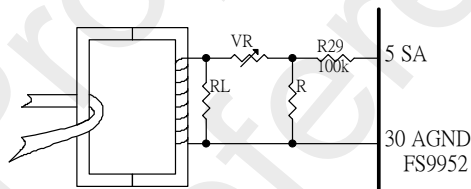

Diagram 31 AC Large Current Measurement

15.17 Triode hFE Test

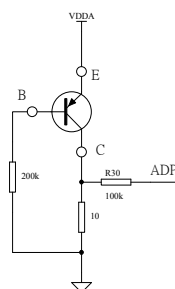

Diagram 32 PNP-type Triode

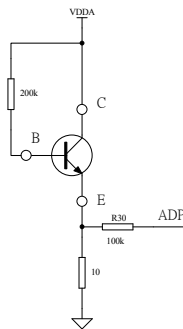

Diagram 33 NPN-type Triode

15.18 Temperature Measurement

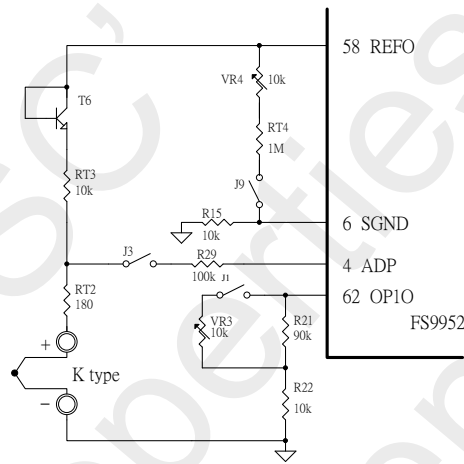

Diagram 34 Temperature Measurement (1)

For the connection of the thermocouple in the diagram, the negative (-) end can be connected directly to the ground (AGND). When the thermocouple is not connected or damaged, it will display overload measurement (OL).

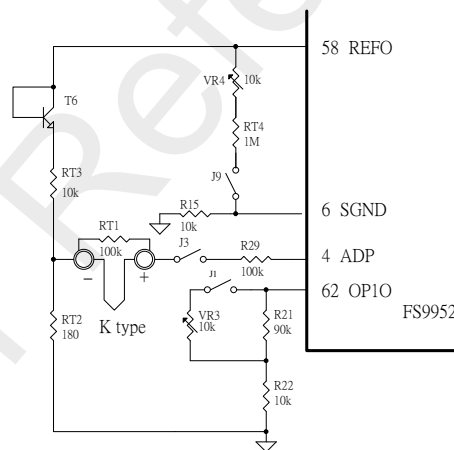
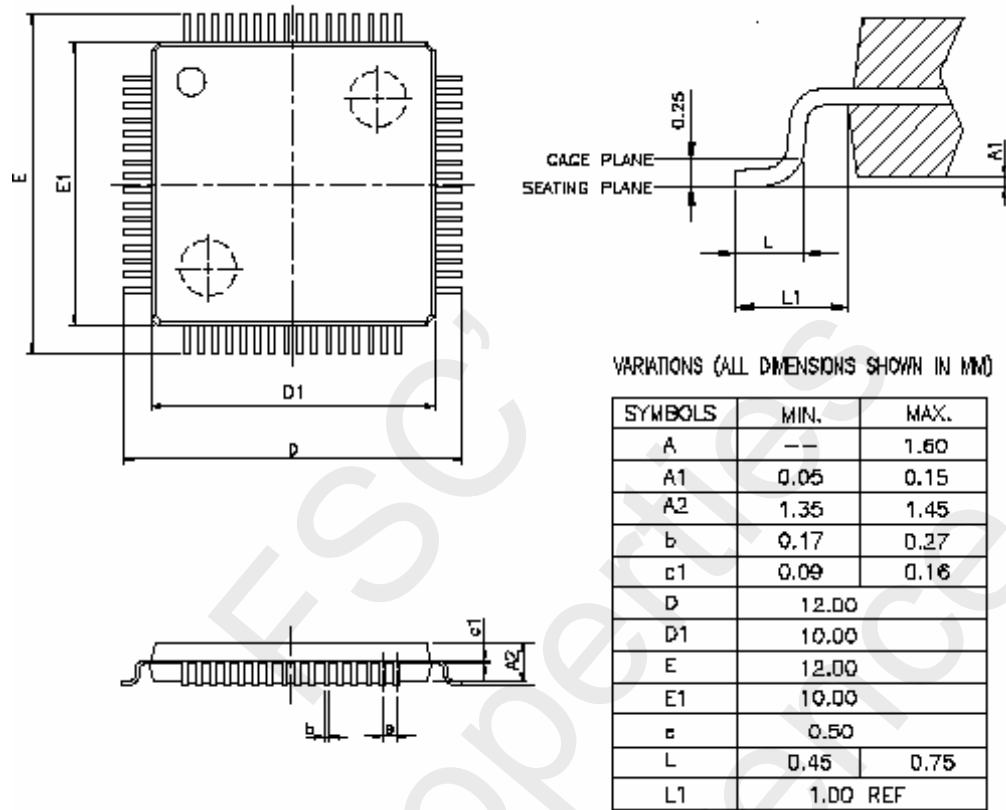

Diagram 35 Temperature Measurement (2)

In the diagram, the connection of the thermocouple is more troublesome, but when the thermocouple is not connected or damaged, it will display the indoor temperature.

16. Package Outline



Package Outline

Diagram 36

17. Ordering Information

Product Number	Package Type
FS9952_LP1	Dice form (64 pins), 64-pin LQFP

**18. Revision History**

<b>Ver.</b>	<b>Date</b>	<b>Page</b>	<b>Description</b>	<b>Revised By</b>
1.7	2004/04/09	2, 25	<ol style="list-style-type: none"> <li>1. Change file name format from "FS9952_LP1 Data Sheet_V1.6.doc" to "FS9952_LP1_DataSheet_V16.doc".</li> <li>2. Change page top and bottom space format.</li> <li>3. Change the first page contents; add "2,000 counts auto range DMM IC".</li> <li>4. Change the data sheet update date from July 2002 to March 2004 on page 2.</li> <li>5. Add ordering information.</li> </ol>	Tommy Chen
1.8	2006/08/03	17	Change the resistance R2 from 100K TO 82K,change the resistance R15 from 10K to 1K	Zhenxing.hu
		18	Change Diagram 7 Power System the resistance R2 from 100K to 82K	

FSC Properties Only  
For Reference