



FSA8049

Audio Jack Detection and Configuration, MIC / GND Cross Point Switch

Features

Detection	Audio Plug GND & MIC Polarity
V _{DD}	2.5 to 4.4 V
THD (MIC)	0.002% Typical
ESD (IEC 61000-4-2) (Air Gap)	15 kV
Operating Temperature	-40°C to 85°C
Package	9-Ball WLCSP 3x3 Array, 0.4 mm Terminal Pitch, 250 μm Ball
Top Mark	M3
Ordering Information	FSA8049UCX

Description

The FSA8049 is an audio jack detection switch for 3- or 4-pole accessories. The FSA8049 detects the locations of ground (GND) and microphone (MIC) poles on the audio plug and automatically routes them to the appropriate connections. This allows the end user to plug accessories, such as headsets with different audio pole configurations, into the mobile device and have them operate correctly.

- Detects 3- or 4-pole audio accessories
- Detects polarity of GND and MIC on 4-pole plugs
- Automatically routes GND and MIC to audio jack terminals

Related Resources

- For evaluation boards and questions, please contact: Analog.Switch@fairchildsemi.com.

Applications

- Cellular Phones, Smart Phones
- MP3 and Portable Multimedia Player

Typical Application

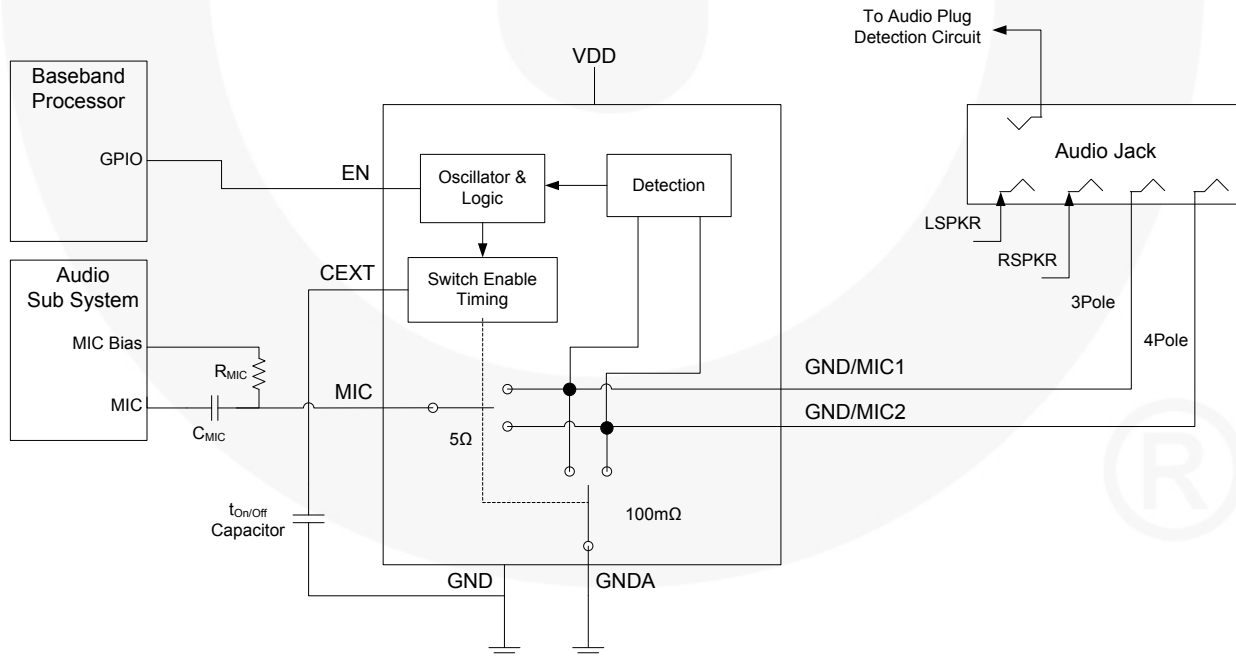

Figure 1. Mobile Phone Example

Pin Configuration

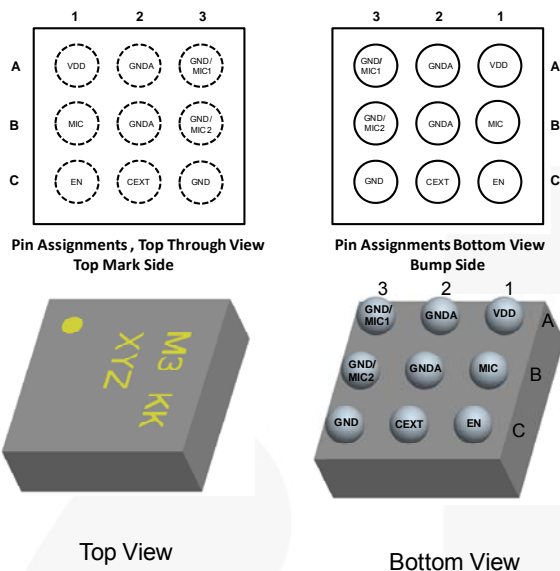
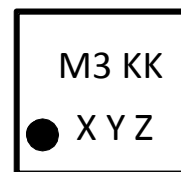

Figure 2. Pin Assignments



M3 = FSA8049UCX Product Identifier
 KK = Lot Run Trace Code
 X = Year
 Y = Work Week
 Z = Assembly Site (P= Penang, Malaysia)
 ● = Pin 1 Indicator

Figure 3. Top Mark

Pin Descriptions

Name	Ball	Type	Description		
VDD	A1	Power	Supply voltage		
GNDA	A2	GND	Switch Ground ⁽¹⁾		
GND/MIC1	A3	I/O	Switch connects to audio jack		
MIC	B1	I/O	Switch connects to audio subsystem microphone pre-amplifier		
GNDA	B2	GND	Switch Ground ⁽¹⁾		
GND/MIC2	B3	I/O	Switch connects to audio jack		
EN	C1	Input	Enable (0=V _{IL} , 1=V _{IH})	0	Disabled
				1	Enabled
CEXT	C2	Input	External capacitor for switch slow t _{ON/OFF} timing		
GND	C3	GND	Device Ground ⁽¹⁾		

Note:

- GND and GNDA can be shorted together if the system does not utilize an FM antenna on the handset ground. If the system utilizes an FM antenna on the handset ground; separate GND and GNDA, place the FM-decoupling inductor and capacitor on GNDA only, and connect GND to a low-impedance path to battery ground.

States of Pins after Audio Jack Detection

State of pins GND/MIC1, GND/MIC2, and MIC after detection time (t_{DET}) is complete.

GND/MIC1	GND/MIC2	Switch Configuration	Accessory Connected
0 (GND)	0 (GND)	GND/MIC1=GND, GND/MIC2=GND, MIC=GND	3-Pole Headphones
0 (GND)	1 (MIC Attached)	GND/MIC1=GND, GND/MIC2=MIC	4-Pole Headset with Microphone
1 (MIC Attached)	0 (GND)	GND/MIC1=MIC, GND/MIC2=GND	4-Pole Headset with Microphone

Absolute Maximum Ratings

Stresses exceeding the absolute maximum ratings may damage the device. The device may not function or be operable above the recommended operating conditions and stressing the parts to these levels is not recommended. In addition, extended exposure to stresses above the recommended operating conditions may affect device reliability. The absolute maximum ratings are stress ratings only.

Symbol	Parameter	Min.	Max.	Unit	
V	Supply Voltage from Battery	-0.5	6.0	V	
V _{SW}	Switch I/O Voltage	-0.5	V _{CC} +0.5	V	
I _{IK}	Input Clamp Diode Current	-50		mA	
I _{SW}	Switch I/O Current (Continuous) ⁽²⁾		50	mA	
T _{STG}	Storage Temperature Range	-65	+150	°C	
T _J	Maximum Junction Temperature		+150	°C	
T _L	Lead Temperature (Soldering, 10 Seconds)		+260	°C	
ESD	IEC 61000-4-2 System ESD	Air Gap	15		kV
		Contact	8		
	Human Body Model, JEDEC JESD22-A114	GND/MIC _n vs. GND	11		
		VDD vs. GND	16		
		All Pins	7		
	Charged Device Model, JEDEC JESD22-C101	All Pins	1.5		

Note:

- The input and output negative ratings may be exceeded if the input and output diode current ratings are observed.

Recommended Operating Conditions

The Recommended Operating Conditions table defines the conditions for actual device operation. Recommended operating conditions are specified to ensure optimal performance to the datasheet specifications. Fairchild does not recommend exceeding them or designing to Absolute Maximum Ratings.

Symbol	Parameter	Min.	Max.	Unit
V _{DD}	Supply Voltage	2.5	4.4	V
V _{EN}	Enable Input Voltage	0	V _{DD}	V
T _A	Operating Temperature	-40	+85	°C

DC Electrical Characteristics

All typical values are at $T_A=25^\circ\text{C}$ unless otherwise specified.

Symbol	Parameter	V_{DD} (V)	Condition	$T_A=-40$ to $+85^\circ\text{C}$			Unit
				Min.	Typ.	Max.	
MIC Switch (MIC to (GND/MIC1 or GND/MIC2))							
$R_{ON(MIC)}$	MIC Switch On Resistance	2.8	$I_{OUT}=24\text{ mA}, V_{IN}=1.8\text{ V}$		3.00	5.00	Ω
		3.8			2.50	4.00	
$R_{FLAT(ON)}$	On Resistance Flatness	2.8	$I_{OUT}=24\text{ mA}, V_{IN}=1\text{ V to }V_{DD}$		0.25	0.50	Ω
		3.8			0.20	0.40	
$V_{IN(MIC)}$	Switch Input Voltage Range	2.7 to 4.4		0		V_{DD}	V
$C_{ON(MIC)}$	MIC Switch On Capacitance ⁽³⁾	3.8	$f=1\text{ MHz}$		90		pF
$C_{OFF(MIC)}$	MIC Switch Off Capacitance ⁽³⁾	3.8	$f=1\text{ MHz}$		21		pF
GND Switch (GND to (GND/MIC1 or GND/MIC2))							
$R_{ON(GNDA)}$	GND Switch On Resistance	2.8	$I_{OUT}=24\text{ mA}$		90	170	m Ω
		3.8			80	100	
$V_{IN(GNDA)}$	Switch Input Voltage Range	2.7 to 4.4		0		1	V
$X_C(GNDA)$	GND Switch On Reactance ⁽⁴⁾	3.8	$f=88\text{ MHz to }108\text{ MHz}, V_{IN}=50\text{ mV}$		100		m Ω
Parallel I/O							
V_{IH}	Input High Voltage	2.7 to 4.4		1.1		V_{DD}	V
V_{IL}	Input Low Voltage	2.7 to 4.4		0		0.55	V
I_{CCT}	Increase in Quiescent Supply Current	4.4	$EN=1.3\text{ V}$			3	μA
Current							
I_{OZ}	Switch Leakage Current	4.4	$GND/MIC_n=1\text{ V}, 4.3\text{ V}; MIC=4.3\text{ V}, 1\text{ V}; EN=LOW$	-75		75	nA
I_{IN}	Input Leakage Current	0 to 4.4	$EN\text{ Input }0\text{ to }4.3\text{ V}$			0.1	μA
I_{CC-DIS}	Disabled Current	2.7 to 4.4	$EN=0$		100		nA
I_{CC-EN}	Enabled Current After Detection	2.7 to 4.4	$EN=1$		100		nA
I_{CC-DET}	Current During Detection Mode	2.7 to 4.4	$EN=0 \rightarrow 1, 3\text{-Pole Mode}, GND/MIC1=GND/MIC2$		0.5	2.0	mA

Notes:

3. Guaranteed by characterization.
4. Guaranteed by design.

AC Electrical Characteristics

All typical values are at $T_A=25^\circ\text{C}$ unless otherwise specified.

Symbol	Parameter	V_{DD} (V)	Condition	$T_A = -40$ to $+85^\circ\text{C}$			Unit
				Min.	Typ.	Max.	
MIC Switch							
THD	Total Harmonic Distortion ⁽⁵⁾	3.8	$R_T=600\ \Omega$, $V_{SW}=0.5\ V_{PP}$, $f=20\ \text{Hz}$ to $20\ \text{kHz}$, $V_{IN}=1.8\ \text{V}$ and $2.2\ \text{V}$ (Figure 4)		0.002		%
O_{IRR}	Off Isolation ⁽⁵⁾	3.8	$f=20\ \text{kHz}$, $R_S=32\ \Omega$, $C_L=0\ \text{pF}$, $R_T=32\ \Omega$ (Figure 5)		-108		dB
			$f=20\ \text{kHz}$, $R_S=600\ \Omega$, $C_L=0\ \text{pF}$, $R_T=600\ \Omega$ (Figure 5)		-85		
Parallel I/O							
$t_{ON-GNDA}$	Switch Turn-On Time (MIC & GND Switch), Measure 10/90	3.8	CEXT=Float $R_L=10\ \text{k}\Omega$, $C_L=10\ \text{pF}$		200		μs
			CEXT=0.1 μF $R_L=10\ \text{k}\Omega$, $C_L=10\ \text{pF}$		140		ms
$t_{OFF-GNDA}$	Switch Turn-Off Time (MIC & GND Switch), Measure 10/90	3.8	CEXT=Float $R_L=10\ \text{k}\Omega$, $C_L=10\ \text{pF}$		20		μs
			CEXT=0.1 μF $R_L=10\ \text{k}\Omega$, $C_L=10\ \text{pF}$		6		ms
$t_{OFF-MIC}$	Switch Turn-Off Time (MIC Switch), Measure 10/90	3.8	$R_L=10\ \text{k}\Omega$, $C_L=10\ \text{pF}$		100		ns
t_{ON-DET}	Detection Circuit NMOS On time	2.7 to 4.4			20		μs
$t_{OFF-DET}$	Detection Circuit NMOS OFF time	2.7 to 4.4			20		μs
t_{DET}	Detection Time of Audio Jack GND and MIC Terminals ⁽⁶⁾	2.7 to 4.4	EN=1		50		ms
t_{EN}	Enable / Disable Time	2.7 to 4.4	EN=0 \rightarrow 1, EN=1 \rightarrow 0		15		μs
Power							
PSRR	Power Supply Rejection Ratio ⁽⁵⁾	3.8	Power Supply Noise 300mV _{PP} , Measured 10/90%, $f=217\ \text{Hz}$ Square Wave		-89		dB

Notes:

5. Guaranteed by characterization.
6. Detection time may be longer if there is noise in the system or a poor audio jack connection.

Typical Performance Characteristics

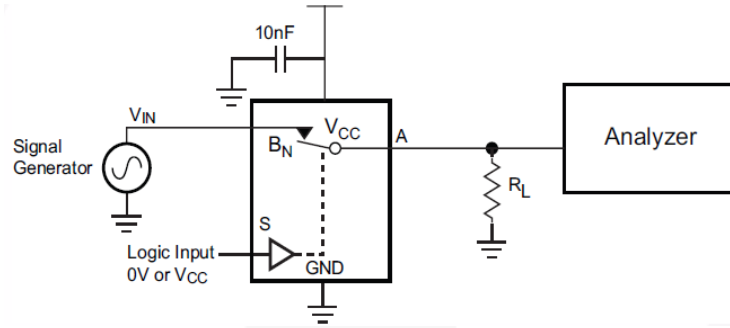

Figure 4. THD Test Setup

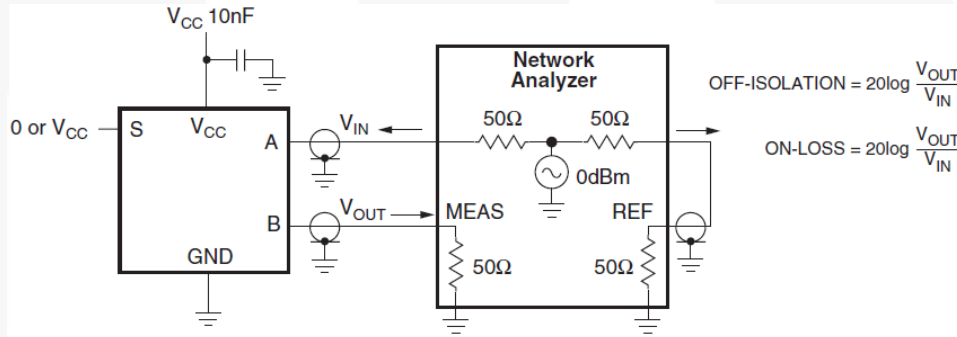

Figure 5. Off Isolation

Physical Dimensions

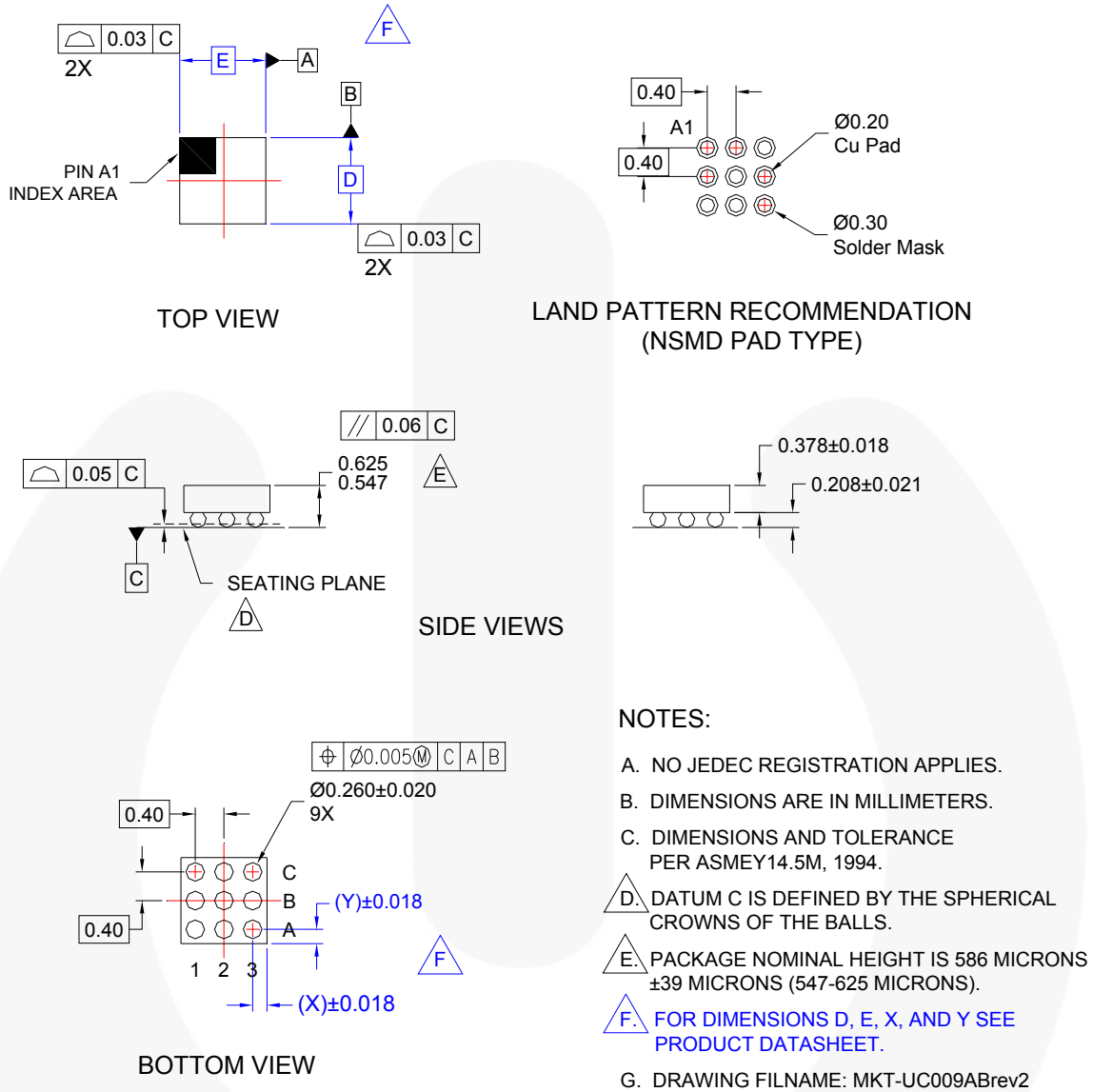

Figure 6. 9-Ball, Wafer-Level Chip-Scale Package (WLCSP), 3x3 Array, 0.4 mm Pitch, 250 µm Ball

Package drawings are provided as a service to customers considering Fairchild components. Drawings may change in any manner without notice. Please note the revision and/or date on the drawing and contact a Fairchild Semiconductor representative to verify or obtain the most recent revision. Package specifications do not expand the terms of Fairchild's worldwide terms and conditions, specifically the warranty therein, which covers Fairchild products.

Always visit Fairchild Semiconductor's online packaging area for the most recent package drawings:
<http://www.fairchildsemi.com/packaging/>

Ordering Information

Part Number	Operating Temperature Range	Top Mark	Package	D	E	X	Y
FSA8049UCX	-40 to +85°C	M3	9-Ball, Wafer-Level Chip-Scale Package (WLCSP), 3x3 Array, 0.4 mm Pitch, 250 µm Ball	1.16 mm	1.16 mm	0.018 mm	0.018 mm



TRADEMARKS

The following includes registered and unregistered trademarks and service marks, owned by Fairchild Semiconductor and/or its global subsidiaries, and is not intended to be an exhaustive list of all such trademarks.

- | | | | |
|--|---|--|---|
| 2Cool™ | F-PFS™ | PowerTrench® | The Power Franchise® |
| AccuPower™ | FRFET® | PowerXS™ | the power franchise |
| AX-CAP™* | Global Power Resource™ | Programmable Active Droop™ | TinyBoost™ |
| BitSiC™ | GreenBridge™ | QFET® | TinyBuck™ |
| Build it Now™ | Green FPS™ | QS™ | TinyCalc™ |
| CorePLUS™ | Green FPS™ e-Series™ | Quiet Series™ | TinyLogic® |
| CorePOWER™ | Gmax™ | RapidConfigure™ | TINYOPTO™ |
| CROSSVOLT™ | GTO™ |  ™ | TinyPower™ |
| CTL™ | IntelliMAX™ | Saving our world, 1mW/W/kW at a time™ | TinyPWM™ |
| Current Transfer Logic™ | ISOPLANAR™ | SignalWise™ | TinyWire™ |
| DEUXPEED® | Making Small Speakers Sound Louder and Better™ | SmartMax™ | Tran SiC™ |
| Dual Cool™ | MegaBuck™ | SMART START™ | TriFault Detect™ |
| EcoSPARK® | MICROCOUPLER™ | Solutions for Your Success™ | TRUECURRENT®* |
| EfficientMax™ | MicroFET™ | SPM® | µSerDes™ |
| ESBC™ | MicroPak™ | STEALTH™ |  ™ |
|  Fairchild® | MicroPak2™ | SuperFET® | UHC® |
| Fairchild Semiconductor® | MillerDrive™ | SuperSOT™-3 | Ultra FRFET™ |
| FACT Quiet Series™ | MotionMax™ | SuperSOT™-6 | UniFET™ |
| FACT® | mWSaver™ | SuperSOT™-8 | VCX™ |
| FAST® | OptoHiT™ | SupreMOS® | VisualMax™ |
| FastvCore™ | OPTOLOGIC® | SyncFET™ | VoltagePlus™ |
| FETBench™ | OPTOPLANAR® | Sync-Lock™ | XS™ |
| FlashWriter®* |  ® |  SYSTEM GENERAL®* | |
| FPS™ | | | |

* Trademarks of System General Corporation, used under license by Fairchild Semiconductor.

DISCLAIMER

FAIRCHILD SEMICONDUCTOR RESERVES THE RIGHT TO MAKE CHANGES WITHOUT FURTHER NOTICE TO ANY PRODUCTS HEREIN TO IMPROVE RELIABILITY, FUNCTION, OR DESIGN. FAIRCHILD DOES NOT ASSUME ANY LIABILITY ARISING OUT OF THE APPLICATION OR USE OF ANY PRODUCT OR CIRCUIT DESCRIBED HEREIN; NEITHER DOES IT CONVEY ANY LICENSE UNDER ITS PATENT RIGHTS, NOR THE RIGHTS OF OTHERS. THESE SPECIFICATIONS DO NOT EXPAND THE TERMS OF FAIRCHILD'S WORLDWIDE TERMS AND CONDITIONS, SPECIFICALLY THE WARRANTY THEREIN, WHICH COVERS THESE PRODUCTS.

LIFE SUPPORT POLICY

FAIRCHILD'S PRODUCTS ARE NOT AUTHORIZED FOR USE AS CRITICAL COMPONENTS IN LIFE SUPPORT DEVICES OR SYSTEMS WITHOUT THE EXPRESS WRITTEN APPROVAL OF FAIRCHILD SEMICONDUCTOR CORPORATION.

As used herein:

1. Life support devices or systems are devices or systems which, (a) are intended for surgical implant into the body or (b) support or sustain life, and (c) whose failure to perform when properly used in accordance with instructions for use provided in the labeling, can be reasonably expected to result in a significant injury of the user.
2. A critical component in any component of a life support, device, or system whose failure to perform can be reasonably expected to cause the failure of the life support device or system, or to affect its safety or effectiveness.

ANTI-COUNTERFEITING POLICY

Fairchild Semiconductor Corporation's Anti-Counterfeiting Policy. Fairchild's Anti-Counterfeiting Policy is also stated on our external website, www.fairchildsemi.com, under Sales Support.

Counterfeiting of semiconductor parts is a growing problem in the industry. All manufacturers of semiconductor products are experiencing counterfeiting of their parts. Customers who inadvertently purchase counterfeit parts experience many problems such as loss of brand reputation, substandard performance, failed applications, and increased cost of production and manufacturing delays. Fairchild is taking strong measures to protect ourselves and our customers from the proliferation of counterfeit parts. Fairchild strongly encourages customers to purchase Fairchild parts either directly from Fairchild or from Authorized Fairchild Distributors who are listed by country on our web page cited above. Products customers buy either from Fairchild directly or from Authorized Fairchild Distributors are genuine parts, have full traceability, meet Fairchild's quality standards for handling and storage and provide access to Fairchild's full range of up-to-date technical and product information. Fairchild and our Authorized Distributors will stand behind all warranties and will appropriately address any warranty issues that may arise. Fairchild will not provide any warranty coverage or other assistance for parts bought from Unauthorized Sources. Fairchild is committed to combat this global problem and encourage our customers to do their part in stopping this practice by buying direct or from authorized distributors.

PRODUCT STATUS DEFINITIONS

Definition of Terms

Datasheet Identification	Product Status	Definition
Advance Information	Formative / In Design	Datasheet contains the design specifications for product development. Specifications may change in any manner without notice.
Preliminary	First Production	Datasheet contains preliminary data; supplementary data will be published at a later date. Fairchild Semiconductor reserves the right to make changes at any time without notice to improve design.
No Identification Needed	Full Production	Datasheet contains final specifications. Fairchild Semiconductor reserves the right to make changes at any time without notice to improve the design.
Obsolete	Not In Production	Datasheet contains specifications on a product that is discontinued by Fairchild Semiconductor. The datasheet is for reference information only.

Rev. I62