

APPLICATION		REVISION				
NEXT ASSY	USED ON	ECN NO	LTR	DESCRIPTION	DATE	APPROVED
	2006-01		X 1	Preliminary Specification		

TFT LCD Controller Board
Specification of
FSB-300U(3Dcombfilter)
(Full-compatible UXGA Panel)

RoHS Compliant.

PROPRIETARY NOTE

THIS DOCUMENT CONTAINS INFORMATION CONFIDENTIAL AND PROPRIETARY TO FSN R&D AND SHALL NOT BE REPRODUCED OR TRANSFERRED TO OTHER DOCUMENTS OR DISCLOSED TO OTHERS OR USED FOR ANY PURPOSE OTHER THAN THAT FOR WHICH IT WAS OBTAINED WITHOUT THE EXPRESSED AND WRITTEN CONSENT OF FSN R&D

APPROVAL		DATE	 FSN Display Inc. TFT LCD Controller Board Ass'y 10.4"/15"/17" / 17" / wide/23"/32"/42" 17"/18.1" / 19" SXGA 20.1"/21.3" UXGA, 24"/UXGA
DRAWN			
CHECKED			
APPROVED			
QA			

양식 702-9(0)	<i>FSN Display Inc.</i>	A4(210×297)mm
-------------	-------------------------	---------------

TABLE OF CONTENTS

Specification Cover -----	1
Revision History -----	3
1. Description -----	4
2. General Specification -----	4
3. Environmental and Reliability Specification -----	5
3.1 Operating Conditions	
3.2 Transportation Conditions	
3.3 Storage Conditions	
3.4 Reliability Specifications	
4. Electrical Specification -----	6
4.1 Panel Compatibility	
4.2 Input Signal Characteristics	
4.3 Output Signal Characteristics	
4.4 Power Management	
4.5 Connector Pin Assignments	
5. Mechanical Specification -----	12
5.1 Main Board Dimension	
5.2 Inverter Board Dimension	
5.3 Key Control Board Dimension	
6. Operation Guide -----	14
6.1 Installation	
6.2 OSD Adjustment	
7. Appendix -----	18
7.1 3Dcombfilter overview	
7.2 Standard Timing Chart	

Revision History

Date	Paragraph	Change Description
2006. 1. 24	Release	1 st Release
2006. 7. 5	Release	2 nd Release
		VideoDecoder change(3Dcombfilter NTSC/PAL/SECAM)
		Chanaging DPMS status LED
		Including sync type : the SOG signal
2006.12.04	Release	Main Chipset changed(for UXGA:Analog RGB 195MHz)
2007.01.31	Release	OSD Menu & Etc. Release

1. Description

FSB-300U Controller board is analog RGB,YPbPr,DVI-D,composite VIDEO and S-video interface board for TFT LCD panel that is providing high quality screen image. This controller board supports from VGA to UXGA resolution at 60Hz refresh rate with expanding to full screen image on the different type of TFT LCD.

It gives a lot of convenience to the user who wants to use different type of LCD panel with this controller and access the GUI.

All user need to prepare are program down load and a right interface cable for the selected LCD panel.

Please refer to the clause 4.1 Panel compatibility.

2. General Specification

ITEM	DESCRIPTION	REMARKS
Model Name	FSB-300U-XXXXX	
LCD Module	VGA/SVGA/XGA TFT LCD with TTL Interface XGA&WXGA&WXGAplus&SXGA&UXGA& UXGA TFT LCD with LVDS Interface	Refer to the clause 4.1 Panel Compatibility
Input Signal	Analog RGB(seperated H/V sync or SOG) DVI-D Composite Video & S-Video	SOG sync type available. Option Available Option Available
Resolution	Hor : 30 to 90 KHz Ver : 50 to85 Hz Analog RGB : VGA~UXGA DVI-D : VGA~UXGA CVBS & S-VIDEO : NTSC/PAL/SECAM	Special timing available MAX res, 1920 X 1200 @ 60Hz. UXGA panel, we need timing margin .(*TBD)
Receptacle	DC Power Jack, D-SUB, DVI-D, VHS, SVHS	RS232,Component optional
User Controls	8 Buttons Controls 5 Language OSD Menu Remote Controls Function UART RS232	English/Italy/Germany/Spanish/ French Option Available Option Available
Image Scaler	FLI5962_LF	GenesisMicrochip,Inc.
Audio	Sub Board	Option Available
Power Consumption	TBD	
Board Dimension	Controller Board : 155 X 130(mm) Key Board : 184 X 24(mm)	
Plug & Play	DDC 2B	VESA

3. Environmental and Reliability Specifications

3.1 Operating Conditions

3.1.1 Temperature : 0°C ~ 60°C (without panel, invert) *operating conditions depend on LCD panels.,

3.1.2 Humidity : 10% ~ 80%, non-condensing

3.1.3 Altitude : maximum 3,000m

3.2 Transportation Conditions

3.2.1 Temperature : -25°C ~ 60°C

3.2.2 Humidity : 5% ~ 95%, non-condensing

3.2.3 Altitude : maximum 15,000m

3.3 Storage Conditions

3.3.1 Temperature : -20°C ~ 80°C

3.3.2 Humidity : 5% ~ 95%, non-condensing

3.3.3 Altitude : maximum 3,000m

3.4 Reliability Specifications

3.4.1 MTBF : more than 50,000 hours at 90% confidence level, excluding LCD panel.

3.4.2 Reliability specification and items : refer to “Specification of reliability test for LCD monitor”

4. Electrical Specification

4.1 Panel Compatibility

FSB-300U supports various Panel with small change. If you want to know which Panel is available, please refer to the following Table. If you want to panel specification, please contact to panel maker or us.

Vendor	Panel Part no.	Deviation Contents								Remarks
SEC	LTM150XH									
	LTM170E04									
	LTM17E05									
	LTM170W-L01									
	LTM190E1									
	LTM213U6									
	LTM240W1									
	LTA400WT									Needs ext SMPS
LG-PHILIPS	LM150X06									
	LM170E01									
	LM181E6									
	LM190E06									
	LC320W01									
	LC420W02									Needs ext SMPS

4.2 Input Signal Characteristics

Input Signal	Description	Unit	Min	Typical	Max	Remarks
DC input	DC Voltage	Vdc	10	12/24	35	*Option
	Power Consumption	Watts		TBD		for full Option
15Pin D-Sub	Video(SOG)	Vp-p		0.714(1.0)		75Ω Terminated
	Sync Voltage	Vp-p		5.0		
	Horizontal Frequency	kHz	15	64	80	Depends on Mode
	Vertical Frequency	Hz	50	75	77	Depends on Mode
DVI-D	Digital RGB	mVp-p	150		1560	
		mVdc	150		1260	
	Dot Clock	MHz	25		165	Depends on Mode
CVBS	Video + Sync	Vp-p		1.0		
S-VHS	LUMA Signal Input	Vp-p	0.339		0.961	
	CHROMA Signal Input	Vp-p	0.339		0.961	
Component	YPbPr(SOG/SOY)	Vp-p		1.02		Not support.

4.3 Output Signal Characteristics

Output Signal	Description	Unit	Min	Typical	Max	Remarks
Invertor Interface	DC Output Voltage	Vdc	10	12/24	35	* Option
	Brightness Control	Vdc	0		5.0	Option
	ON/OFF Control	Vdc	0		5.0	
	Differential Output	mVp-p	250	350	450	
LVDS Interface	LCD Power	Vdc		3.3		
				5		
				12		

4.4 Power Management : VESA DPMS standard is applied for power management control.

Mode	HSync.	VSyn.	Video signal	LED Indication	Power Consumption (nominal)
On	Active	Active	Active	Green LED	< 54 W
Stand-by	Inactive	Active	Active	Red LED	< 5 W
Suspend	Active	Inactive	Active	Red LED	
Off	Inactive	Inactive	Active	Ambor LED	

4.5 Connector Pin Assignment

4.5.1 CN16 & JS1 : DC Input Option

Part No.	Pin No	CN16 Description	JS1 Description	Remarks
DJ023 / PWR 4P	1	VCC(12V5A)	VCC(24V/10A)	CN16 INNER 12V
	2	GND	VCC(24V/10A)	
	3	GND	GND	
	4		GND	

4.5.2 CON1 : DVI-D Input (Option Available)

Part No.	Pin No.	Description	Remarks
SD74320-003 (MOLEX)	1	TMDS DATA 2-	
	2	TMDS DATA 2+	
	3	TMDS DATA 2/4 Shield	
	4	TMDS DATA 4- (NC)	
	5	TMDS DATA 4+ (NC)	
	6	DDC Clock	
	7	DDC Data	
	8	NC	
	9	TMDS DATA 1-	
	10	TMDS DATA 1+	
	11	TMDS DATA 1/3 Shield	
	12	TMDS DATA 3- (NC)	
	13	TMDS DATA 3+ (NC)	
	14	5V	
	15	GND	
	16	Hot Plug Detect	
	17	TMDS DATA 0-	
	18	TMDS DATA 0+	
	19	TMDS DATA 0/5 Shield	
	20	TMDS DATA 5- (NC)	
	21	TMDS DATA 5+ (NC)	
	22	TMDS DATA Clock Shield	
	23	TMDS Clock+	
	24	TMDS Clock-	

4.5.3 CN5 : S-Video Input (Option Available)

Part No.	Pin No.	Description	Remarks
DJ-M404	1	GND	
	2	GND	
	3	CHROMA	
	4	LUMA	
	5	GND	

4.5.4 J14 : CVBS Input (Option Available)

Part No.	Pin No.	Description	Remarks
DC003Y	1	Composite Video	
	2	GND	
	3	GND	

4.5.5 P1 : Analog RGB Input

Part No.	Pin No.	Description	Remarks
DB15HD	1	RED	
	2	GREEN	
	3	BLUE	
	4	GND	
	5	GND (DDC RETURN)	
	6	GND-RED	
	7	GND-GREEN	
	8	GND-BLUE	
	9	NC	
	10	GND-SYNC/SELF TEST	
	11	GND	
	12	DDC DATA	
	13	HORIZONTAL SYNC	
	14	VERTICAL SYNC	
	15	DDC CLOCK	

4.5.6 CN3 : OSD Key Control

Part No.	Pin No.	Description	Remarks
12505WR9P (Yeonho)	1	LED_R	
	2	LED_G	
	3	KEY INPUT1	*ADC INPUT
	4	KEY INPUT2	
	5	IR	
	6	GND	
	7	GND	
	8	+5V	
	9	+5V	

4.5.7 J5 : RS232 Port

Part No.	Pin No.	Description	Remarks
WR4P (Yeonho)	1	+3.3V Speed:115200bps	
	2	RX (PC -> Board)	
	3	TX (Board -> PC)	Baud Rate :
	4	GND	115200 bps

양식 702-9(0)	<i>FSN Display Inc.</i>	A4(210×297)mm
-------------	-------------------------	---------------

4.5.8 CN2 & J6 : Output to Panel

Part No.	CN11 Pin No.	CN12 Pin No.	CN11 Description	CN12 Description	Remarks
12507WR30P (Yeon ho)	1	1	Panel power	RED0	
	2	2	Panel power	RED1	
	3	3	Panel power	RED2	
	4	4	NC	RED3	
	5	5	NC	RED4	
	6	6	NC	RED5	
	7	7	GND	RED6	
	8	8	RxE3+	RED7	
	9	9	RxE3-	GND	
	10	10	RxEC+	GND	
	11	11	RxEC-	GREEN0	
	12	12	RxE2+	GREEN1	
	13	13	RxE2-	GREEN2	
	14	14	GND	GREEN3	
	15	15	RxE1+	GREEN4	
	16	16	RxE1-	GREEN5	
	17	17	GND	GREEN6	
	18	18	RxE0+	GREEN7	
	19	19	RxE0-	GND	
	20	20	RxO3+	GND	
	21	21	RxO3-	BLUE0	
	22	22	RxOC+	BLUE1	
	23	23	RxOC-	BLUE2	
	24	24	GND	BLUE3	
	25	25	RxO2+	BLUE4	
	26	26	RxO2-	BLUE5	
	27	27	RxO1+	BLUE6	
	28	28	RxO1-	BLUE7	
	29	29	RxO0+	GND	
	30	30	RxO0-	GND	
		31		HSYNC	
		32		VSYNC	
		33		DEN	
		34		GND	
		35		DEN	
		36		DCLK	
		37		Panel power	
		38		Panel power	
		38		Panel power	
		40		Panel power	

* Panel powers are 3.3V,5V,12V

* CN2 : LVDS 1ch/2ch

* J6 : TTL 1ch(18, 25 bits)

4.5.9 J11 : Output to Inverter

CN14 Part No.	Pin No.	.		Description	Remarks
12505WR15P (Yeonho)	1			GND	
	2			DIMMING	
	3			GND	
	4			BRT ON/OFF	
	5			GND	
	6			GND	
	7			NC	
	8			GND	
	9			GND	
	10			VDD	
	11			VDD	
	12			VDD	
	13			VDD	
	14			VDD	
	15			VDD	

4.5.10 : J8/J10 Connect to Inverter

J8/J11	Pin No.	Description	Remarks				
SMW200-12 (Yeonho)	1	DIMMING					
	2	Backlight on/off					
	3	GND					
	4	GND					
	5	GND					
	6	GND					
	7	GND					
	8	24V or equ					
	9	24V or equ					
	10	24V or equ					
	11	24V or equ					
	12	24V or equ					

4.5.11 5 : J12 Board Power connector

J12	Pin No.	Description	Remarks
SMW200-12 (Yeonho)	1	DIMMING	
	2	Backlight on/off	
	3	SMPS Power On/Off	
	4	GND	
	5	GND	
	6	GND	
	7	GND	
	8	NC	
	9	12V , 24V or equ	
	10	12V , 24V or equ	
	11	12V , 24V or equ	
	12	12V , 24V or equ	

* To Understand abobe table, see the blockdiagram.

5. Mechanical Specification

5.1 Main Board Dimension

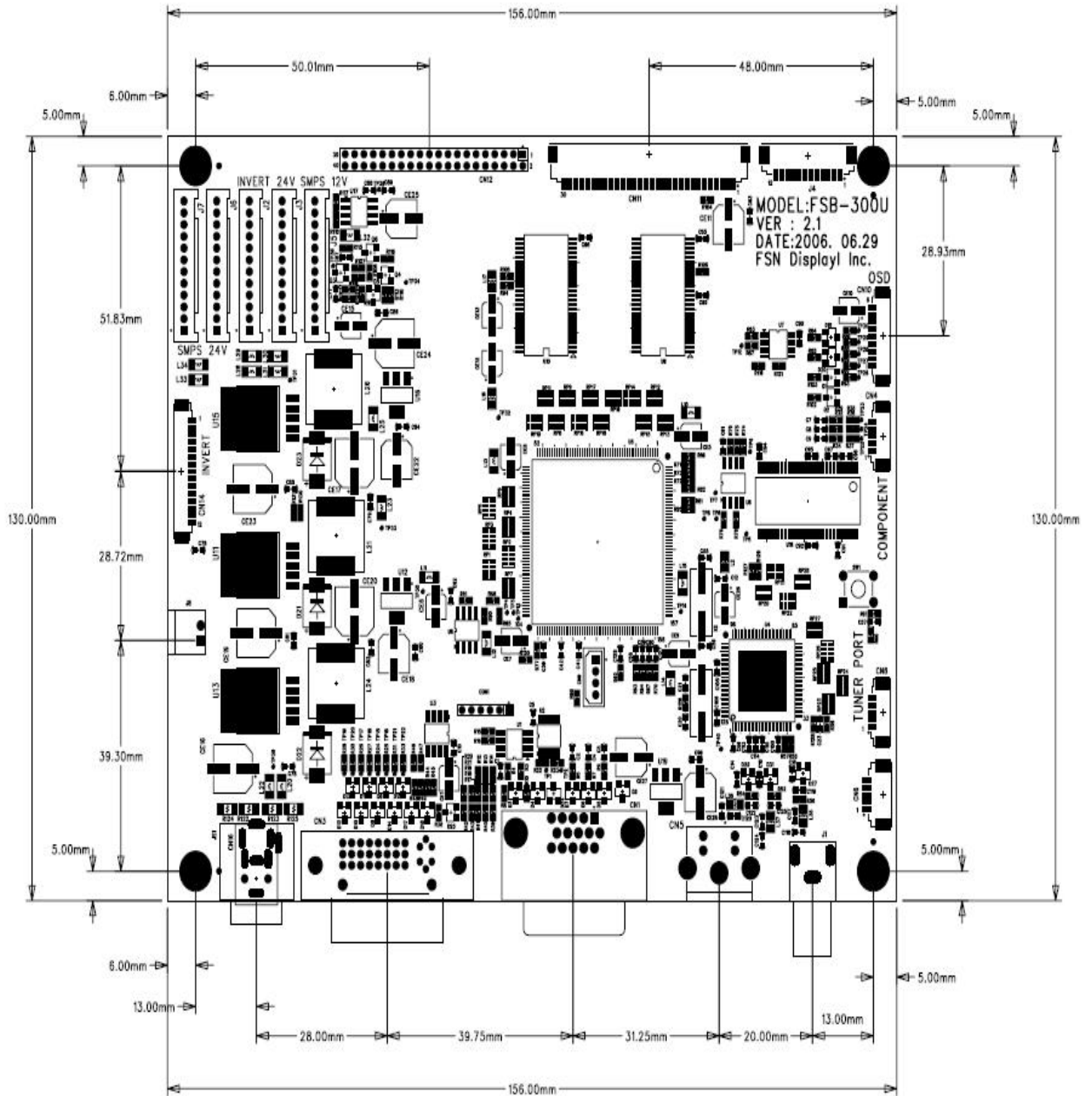

5.3.1 Key Control Board Dimension

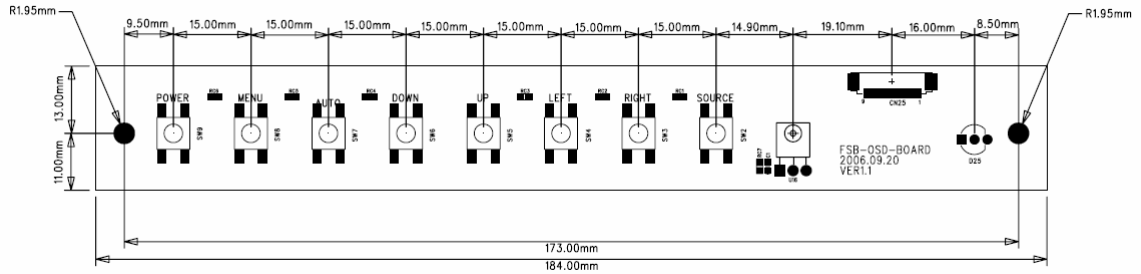

Button place from left to right:

POWER/MENU/AUTO/DOWN/UP/LEFT/RIGHT/SOURCE/IR

5.3.1 Remocon



- POWER - System On/off
- SOURCE - Change functions
- Menu - Menu On/Off
- Up/Down - Set the zoom value and adjust the scalers accordingly & Menu Move
- Left/Right – Volume control & Menu Move
- PIP - Pip window On/Off
- AUTO - Auto configuration of RGB display.
- PIP SIZE- Pip window size changes (option)
- PIP POS - Pip window position changes. (option)
- PIP SRC : Pip window source changes. (option)

* Below keys used for special function.

* Before using the Remocon for the first time, install the two AAA batteries.(Not supplied)

* Remocon is optional-product

5.4 Blockdiagram of +12V inverter interconnection

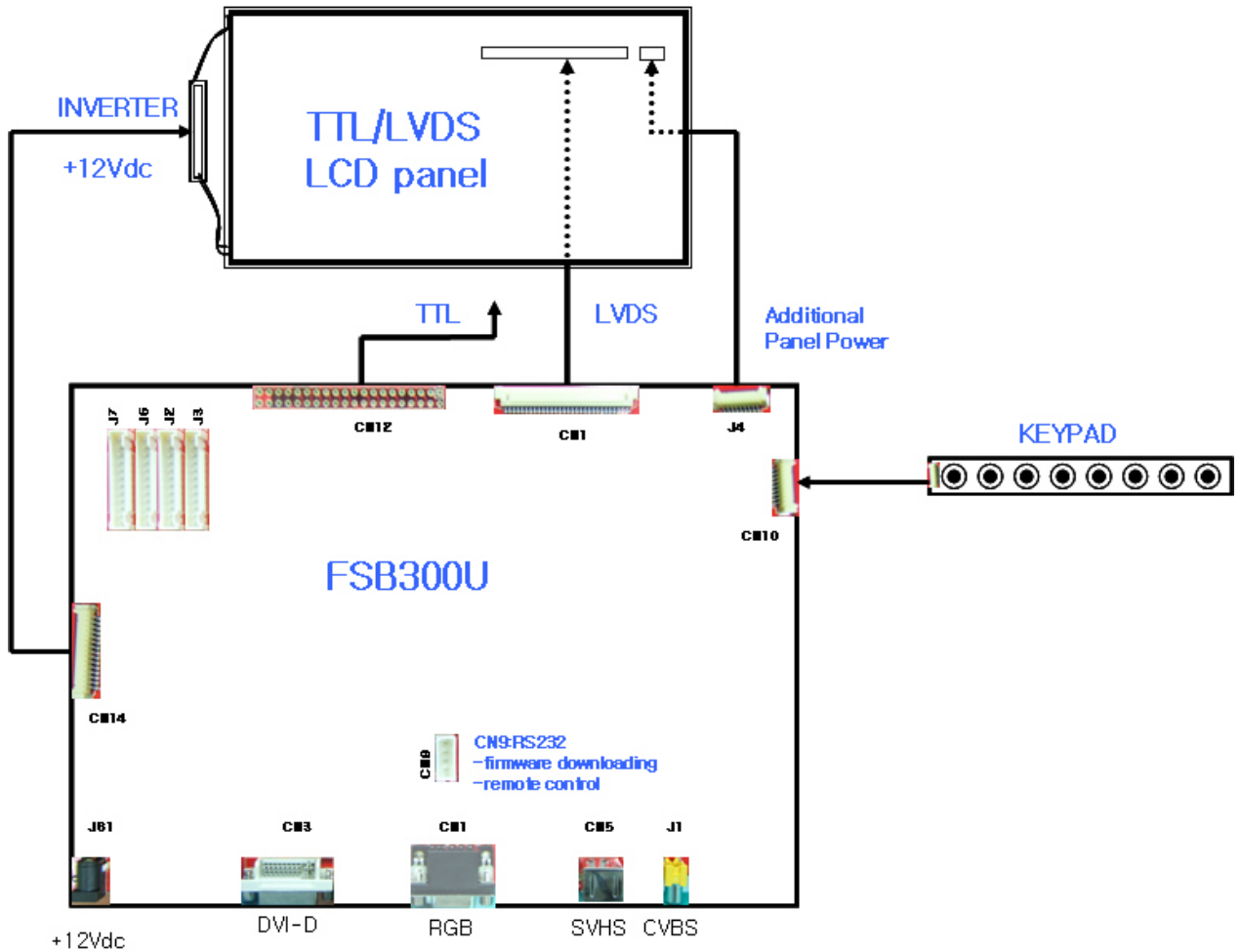

5.5 Blockdiagram of +24V inverter interconnection for big size panel

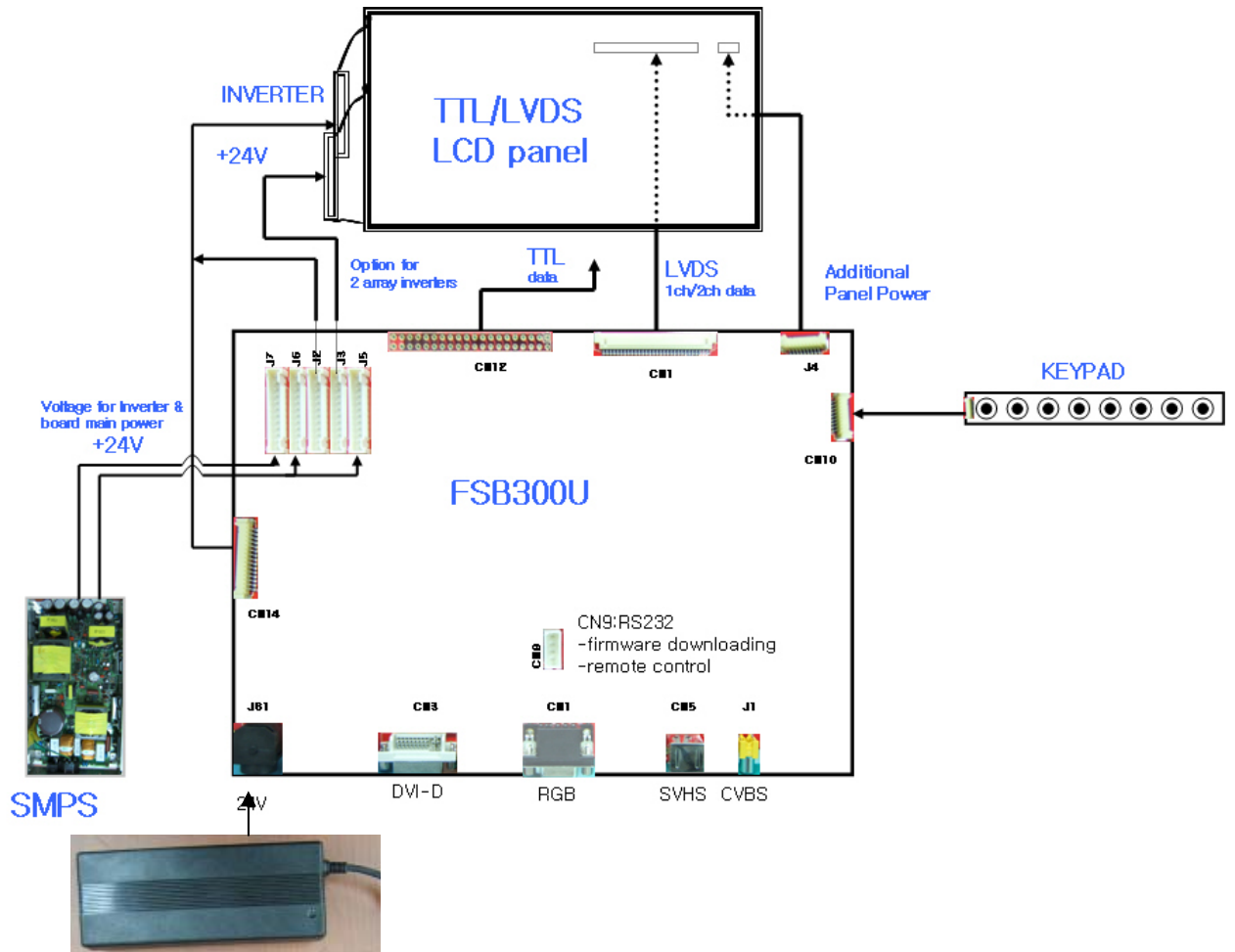

6. Operation Guide

6.1 Installation

This controller is designed for RGB/Video/Componet multi-function monitor using different size of LCD panels. This section provides some guidelines for assembly and preparation of a finished display solution. Before proceeding, it is important to familiarize yourself with the parts making up a system and the various connectors, mounting holes and general layout of the controller. Please follow the below procedure.

1) LCD Panel Connection

Please check the Panel Power, Interface type and Inverter. Refer to the clause 4.1 Panel Compatibility and check if the controller board is matching with panel or not. Connect the inverter and controller board to the panel.

2) Inverter Connection

Each LCD panel has their own inverter to obtain optimum performance and long lifetime. The controller board just supplies the power for inverter logic and controls On/Off signal and brightness control signal. So, it is important to use the proper inverter that has proper driving capacity and control input signal. Refer to the clause 4.5 Connector Pin Assignment and connect the inverter cable to inverter and controller board.

3) Key Control Board Connection

Refer to the 4.5 Connector Pin Assignment and connect the key control cable to key control cable and controller board.

4) Signal Inputs Connection

Analog input, DVI input, CVBS and S-Video Signal is available. Please refer to the clause 4.5 Connector Pin Assignment and connect the signal what you want to apply to the controller board. Especially, the Analog RGB and DVI cable may affect the visual characteristics and regulatory emission test. So, a suitably shielded cable should be used.

5) Power Input Connection

Refer to the 4.5 Connector Pin Assignment and connect the power input cable to the controller board. Every connection is done but you should consider electrical insulation, grounding, EMI shielding and heat & ventilation.

6) Apply Power

Apply power and turn on the monitor and refer to the following clause.

6.2 OSD Adjustment

FSB-300U gives various and very easy graphic user interface. User can easily access to the function that user wants. Be sure that your system power and LED is turned on before operating key board.

6.2.1 Key Name and Function

Key Name	Description
Power	Turns ON/OFF the system
Menu	Activates the OSD menu or goes to previous menu
AUTO	Auto-adjustment in RGB
Down	Moves the highlight icon up to the function that user wants
Up	Moves the highlight icon down to the function that user wants
Left	Decreases the adjustment of the selected function
Right	Increases the adjustment of the selected function
Source	Selects the Input Signal among analog RGB/YPbPr/DVI/S-VHS/CVBS
IR	Receives the signal from Remote Control

Accessing the menu system

1. With the OSD off, push the **Menu** button to activate the main OSD menu.
2. Use the **Up** or **Down** buttons to move from one function to another. As you move from one icon to another, the function name changes to reflect the function or group of functions represented by that icon. Please refer to the following clause on the next page to view a complete list of all of the functions available for the driver board.
3. Press the **AUTO** to adjust clock, phase, position of PC input
4. Press the **Menu** button once to return to the main menu to select another function or press twice to exit from the OSD.
5. Press **Left/Right** keys to change values over main-menu display.

6.2.2 OSD Adjustment

MENU Items:

IMAGE >> BRIGHTNESS/CONTRAST/HUE/SATURATION/SHARPNESS/COLOR

DISPLAY >> AUTO CONFIG/PHASE/CLOCK/DISPLAY CONTROL/HIGHLIGHT WINDOW

PIP >> ON/OFF/PIP INPUT SELECT/PIP POSITION/PIP BLEND

SYSTEM >> INPUT SELECT/LANGUAGE/MISC

6.2.3 Functions on OSD Menu

Image Menus:

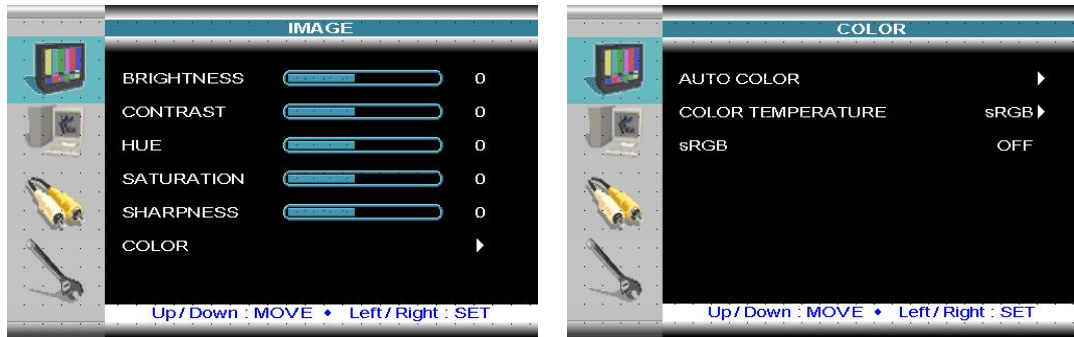

- Brightness : adjust the brightness of the screen
- Contrast : adjust the contrast of the screen
- Hue : adjust the hue of the video(optional video function)
- Saturation : adjust the color saturation of the video(Enabled in video function)
- Sharpness : adjust the sharp of image(Enabled in video function)
- Color : adjust the color items of screen, it goes the sub osd menu.(Enabled in RGB function)

- Auto Color : Calibrate input pixels; it expands dynamic range
- Color temperature : adjust the color temperature; 9300K,7500K,6500K,5000K,4200K,USER mode
- sRGB : On/Off sRGB funtion



User Red, Green, Blue submen:
Adjust color gain

Display Menus:

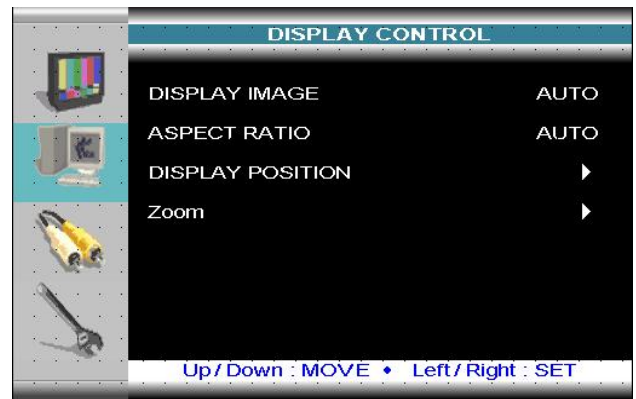
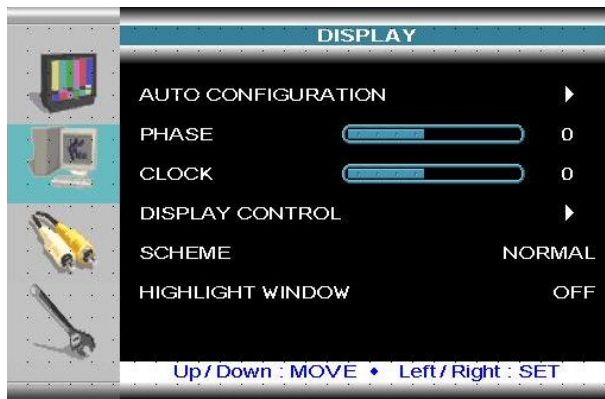

- Auto Configuration : adjust the clock/phase/position of display automatically(Enabled in RGB function)
- Phase : adjust the phase of the screen (Enabled in RGB function)
- clock : adjust the clock(frequency) of the screen(Enabled in RGB function)
- Display Control : It goes to the sub-menu (DisplayControl), adjust Aspect, 1:1, panoramic. Aspect functions are 4:3, 14:9, 16:9, auto mode
- Scheme : adjust environment image of the screen; Normal, Vivid, Cinema
- Highlight Window : On/Off the color enhancement functions.
- Zoom : It goes to the sub-menu ZOOM.

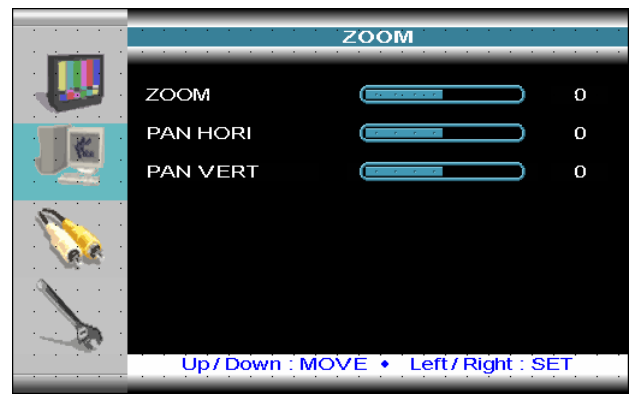
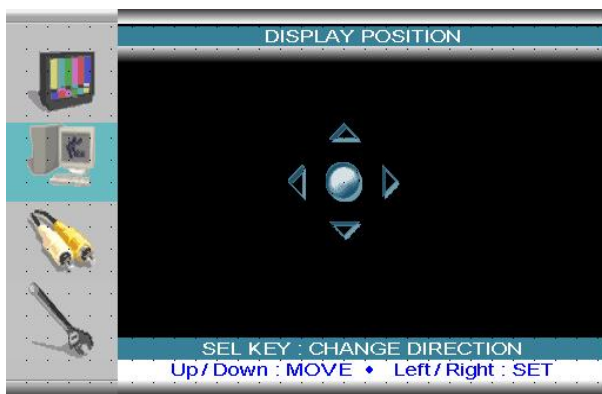

- Display Position: adjust the position of image. Left/Right/Up/Down keys control the position.
- Pan Hori : the Horizontal Pan is set of the display horizontal position.
- Pan Vert : the Vertical Pan is set of the display vertical position.

Pip Menus:

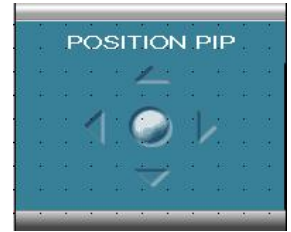

- PIP Mode : On/Off the Pip(picture in picture) function
- PIP Source : Select input signals of pip
- PIP Size : Adjust the Pip image size & PBP window set.
: Small(400x300), Medium(520x390), Large(600x450), PBP Window
- PIP Position: Adjust the Pip position
: It can be 5-positions.(left-top, left-bottom, Center, right-top, right-bottom)
- PIP Image: It goes to sub-menu
: Adjust the color factors of image.
- PIP Blend : Adjust the transparency of Pip image
- Brightness : adjust the brightness of the screen
- Contrast : adjust the contrast of the screen
- Hue : adjust the hue of the video(optional video function)
- Saturation : adjust the color saturation of the video(Enabled in video function)

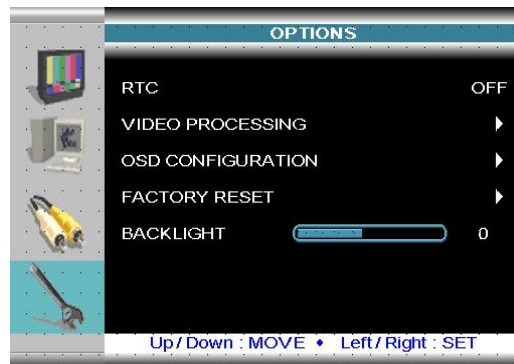
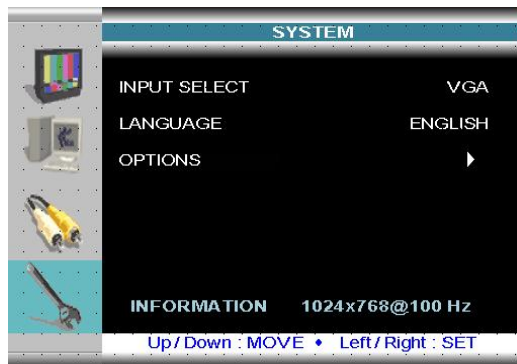

- Input Select : Selects the input signal, Rotate RGB,DVI,COMPOSITE,S-VHS,Y pb Pr functions.
- Language : adjust the OSD language.
- Options : It goes to sub-menus.

<<Information 1024x768@100Hz>> display the input mode.

- RTC : On/Off the RTC(Response Time Compensator)
- OSD Configuration: It goes to sub-menus.
- Factory Reset : Set default values.
- Backlight : Set the PWM level

System Menus(continued):

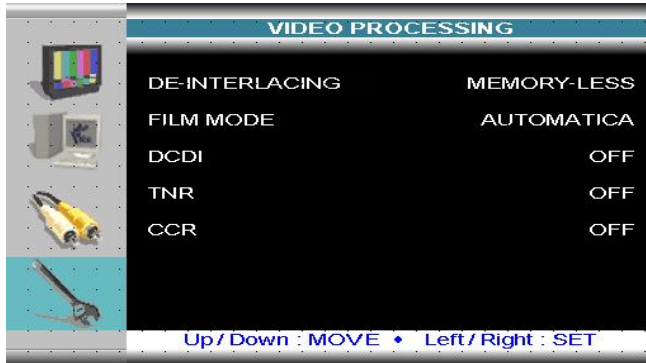

-De-Interlacing : Select MADi & Memory-less. It's about deinterlacing skill.

If you want to see the natural display, you should the MADi(Motion Adaptive De-interlacing)

-Film Mode : Select Film-mode functions.

-DCDI :Select the Faroudja TM DCDi-Edge function.

-TNR : Select the noise reduction function.

-CCR : Select the cross color reduction. It kinds of noise reduction funtion. :

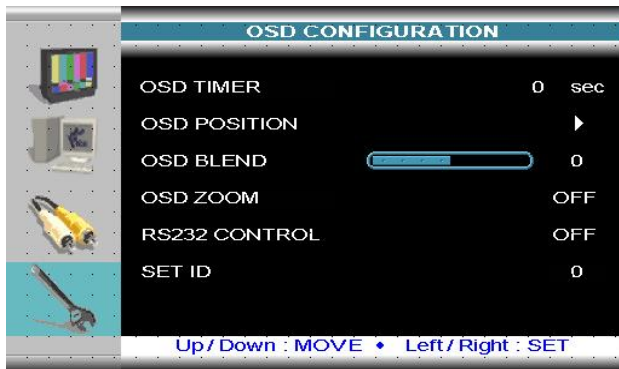

- Osd-Timer : Adjust the osd off timer. It consists of “3sec,6sec,9sec,12sec,off”.

Default value is 6sec..

-Osd Position : It goes to sub-menu. Adjust the osd position :

-Osd Transparency : Adjust the osd transparency.

-OSD Zoom: Select osd size (normal, big)

-RS232 CONTROL : Select the RS232 communication function

-SET ID : You can adjust the set ID to choose desired product ID number in this menu

7. Appendix

7.1 3D combfilter overview.

The FSB-300U provides state of art of new video processing.

It enables ;

1. Timem bass correction
2. 3D Y/C3.

3DNR

4. CTI
5. Edge enhancer
6. etc.,.

For PAL and NTSC video signals. It uses the TI's TVP5160 and Frame Memory. The followings are gereneral features of 3D processing.

7. Appendix

7.1 3Dcombfilter overview.

The FSB-300U provides state of art of new video processing.

It enables ;

1. Timem bass correction
2. 3D Y/C
3. 3DNR
4. CTI
5. Edge enhancer
6. etc,.

For PAL and NTSC video signals. It uses the TI's TVP5160 and Frame Memory.

The followings are gereneral features of 3D processing.

3D NR compensation.

Origin



3D NR.



CTI compensation

Origin

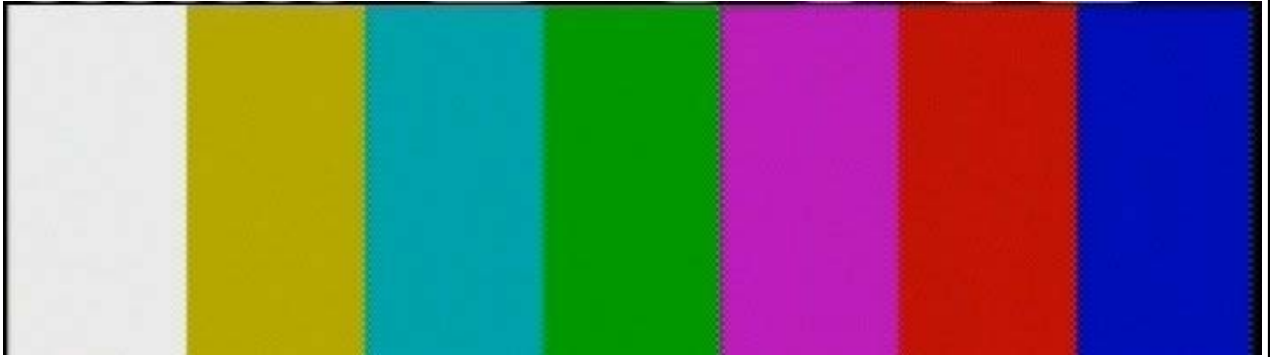

CTI

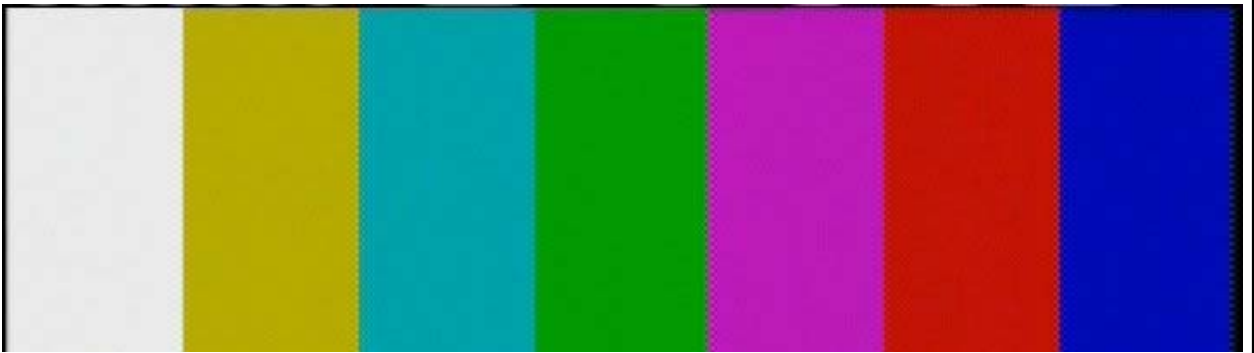

Edge enhacer

3D Y/C compensation

Origin

Origin

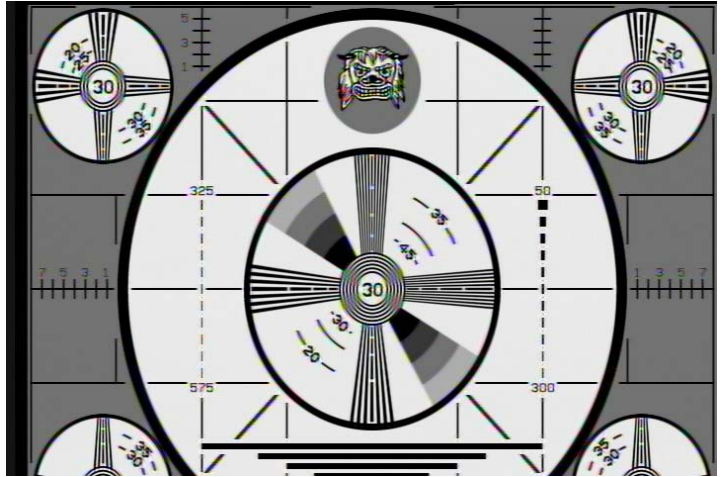

Edge enhacer

3D Y/C

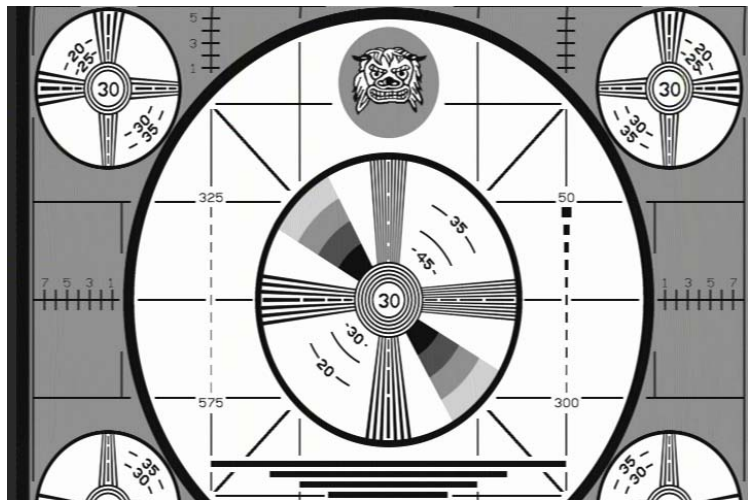

7.2 Standard Timing Chart

Resolution Timing Item	640x350 @70Hz	720x400 @70Hz	640x480 @60Hz	640x480 @75Hz	800x600 @60Hz	800x600 @75Hz	1024x768 @60Hz
Pixel Clock (MHz)	25.175	28.324	25.175	31.500	40.000	49.500	65.000
Sync Polarity(H/V)	P/N	N/P	N/N	N/N	P/P	P/P	N/N
Scanning Type	Progressive	Progressive	Progressive	Progressive	Progressive	Progressive	Progressive
-Hor Frequency(kHz)	31.468	31.469	31.469	37.500	37.879	46.875	48.363
-Period(us)	31.778	31.780	31.778	26.667	26.400	21.333	20.677
-Active time(us)	25.418	25.420	25.422	20.317	20.000	16.162	15.754
-Front porch(us)	0.638	0.640	0.636	0.508	1.000	0.323	0.369
-Sync width(us)	3.823	3.810	3.813	2.032	3.200	1.616	2.092
-Back porch(us)	1.909	1.906	1.907	3.810	2.200	3.232	2.462
-Ver Frequency(Hz)	70.090	70.082	59.940	75.000	60.317	75.000	60.004
-Period(ms)	14.268	14.270	16.683	13.333	16.579	13.333	16.666
-Active time(ms)	11.122	12.710	15.253	12.800	15.840	12.800	15.880
-Front porch(ms)	0.381	0.413	0.064	0.027	0.026	0.021	0.062
-Sync width(ms)	0.064	0.064	0.064	0.080	0.106	0.064	0.124
-Back porch(ms)	1.111	1.080	0.794	0.427	0.626	0.448	0.600
Resolution Timing Item	1024x768 @75Hz	1280x1024 @60Hz	1280x1024 @75Hz	1152x864 @60Hz	1152x864 @75Hz	1600x1200 @60Hz	1920x1200 @60Hz
Pixel Clock (MHz)	78.750	108.50	135.00	80.000	108.00	162.000	193.156
Sync Polarity(H/V)	P/P	P/P	P/P	P/P	P/P	P/P	N/P
Scanning Type	Progressive	Progressive	Progressive	Progressive	Progressive	Progressive	Progressive
-Hor Frequency(kHz)	60.023	63.974	79.976	54.348	67.500	75.000	75.000
-Period(us)	16.660	15.631	12.504	18.400	14.815	13.3	13.42
-Active time(us)	13.003	11.797	9.481	14.400	10.667	9.877	9.940
-Front porch(us)	0.203	0.590	0.119	0.400	0.593	0.395	0.663
-Sync width(us)	1.219	1.180	1.067	1.200	1.185	1.185	1.077
-Back porch(us)	2.235	2.065	1.837	2.400	2.370	1.877	1.740
-Ver Frequency(Hz)	75.029	60.013	75.025	60.053	75.029	60.000	60.000
-Period(ms)	13.328	16.663	13.329	16.652	13.333	16.667	17.026
-Active time(ms)	12.795	16.006	12.804	15.898	12.800	16.000	16.103
-Front porch(ms)	0.017	0.016	0.013	0.017	0.015	0.013	0.013
-Sync width(ms)	0.050	0.047	0.038	0.055	0.044	0.040	0.040
-Back porch(ms)	0.466	0.594	0.475	0.681	0.474	0.613	0.510

8. RS232

8.1 COM Port setting

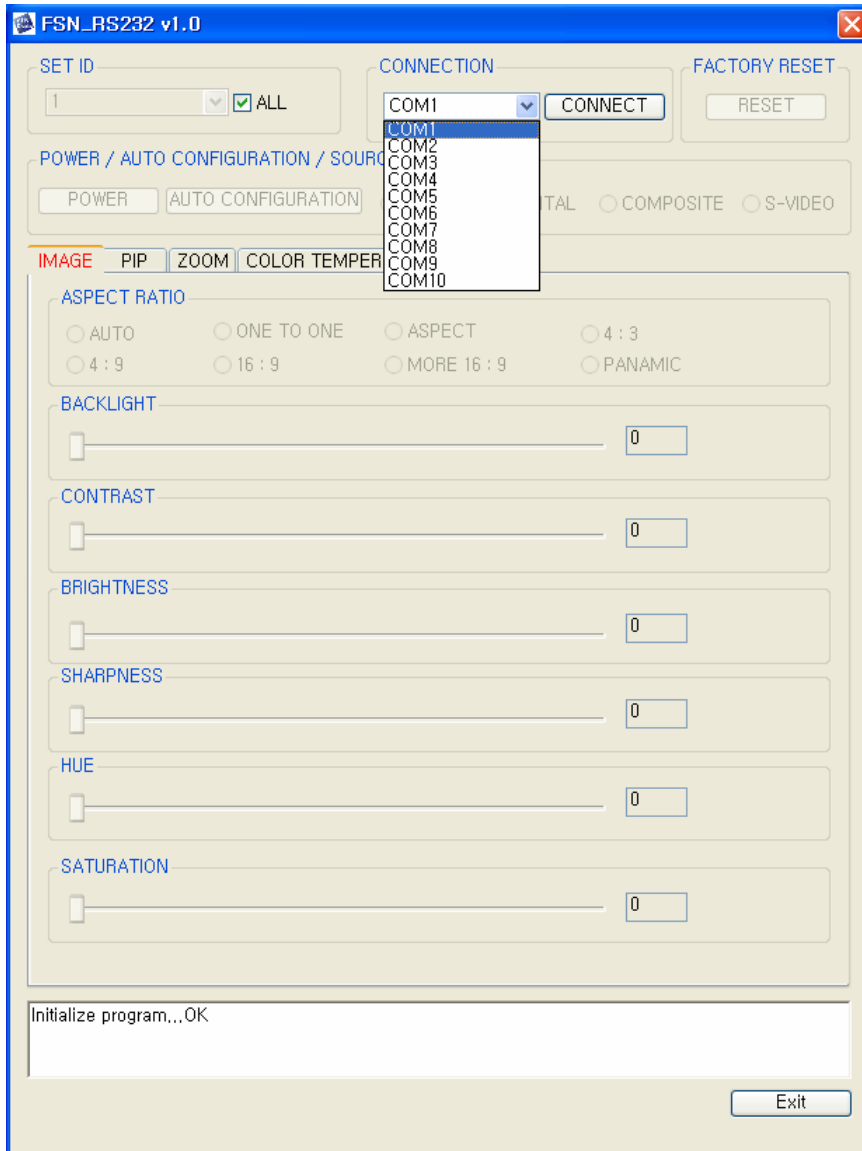

- The COM Port setting is used for connection between the PC COM Port and Monitor
- Power : To control Power On/Off of the Monitor
- Auto Configure : To adjust picture position and image shaking automatically (only in ANALOG mode)
- Source : To select an input source using the radio button (ANALOG, DIGITAL, COMPOSITE, S-VIDEO) on the POWER / AUTO CONFIGURATION / SOURCE group box

8. RS232

8.2 Connect Error Message

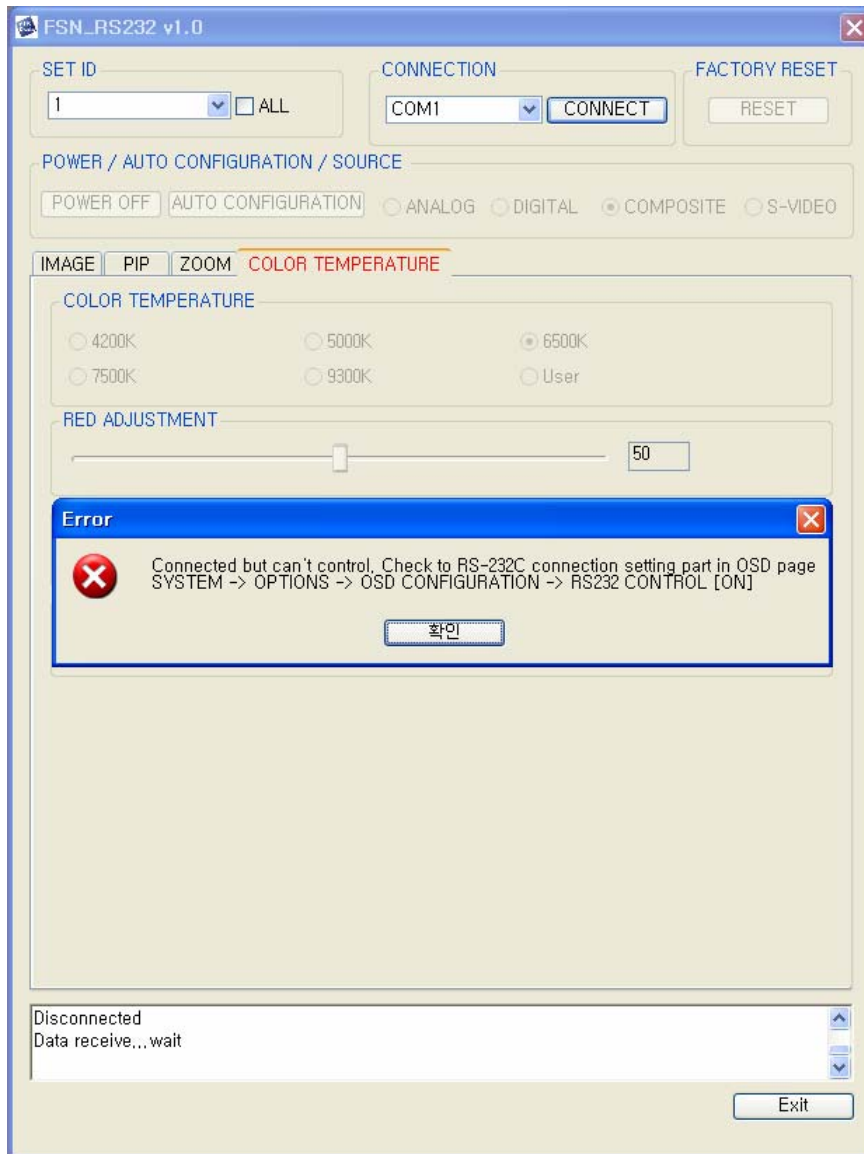

- OSD Menu set
SYSTEM/OPTIONS/OSD CONFIGURATION/RS232 CONTROL ON set.

8.3 SET ID

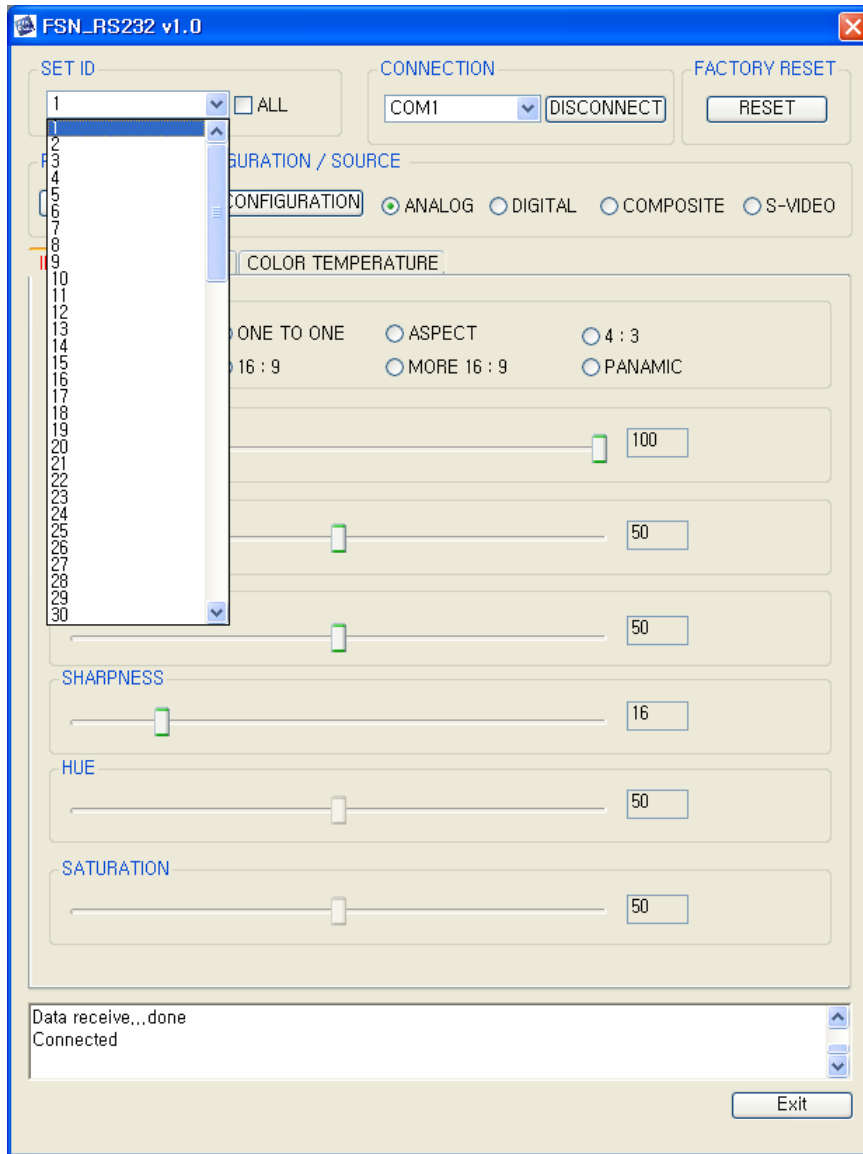

- SET ID : You can adjust the Set ID to choose desired monitor ID number.

8.4 Factory Reset

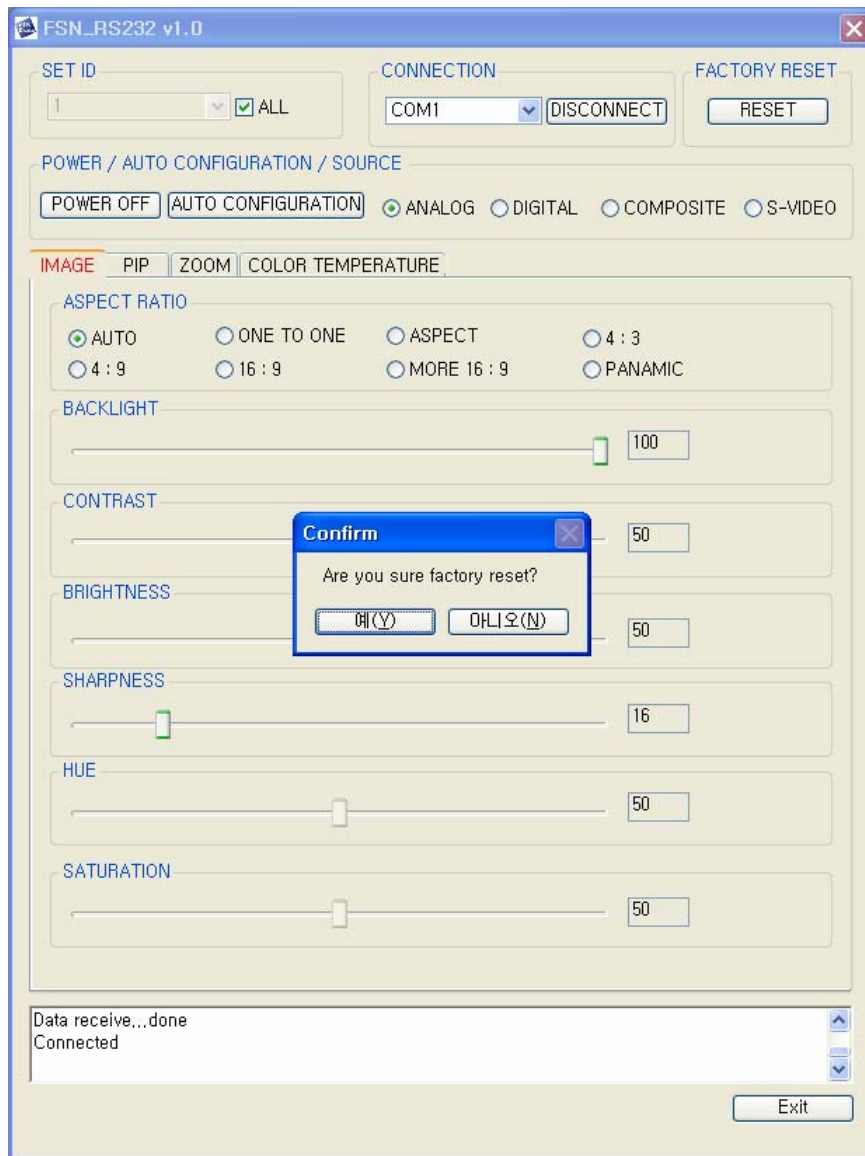

- Factory Reset : Set default value

8.5 IMAGE

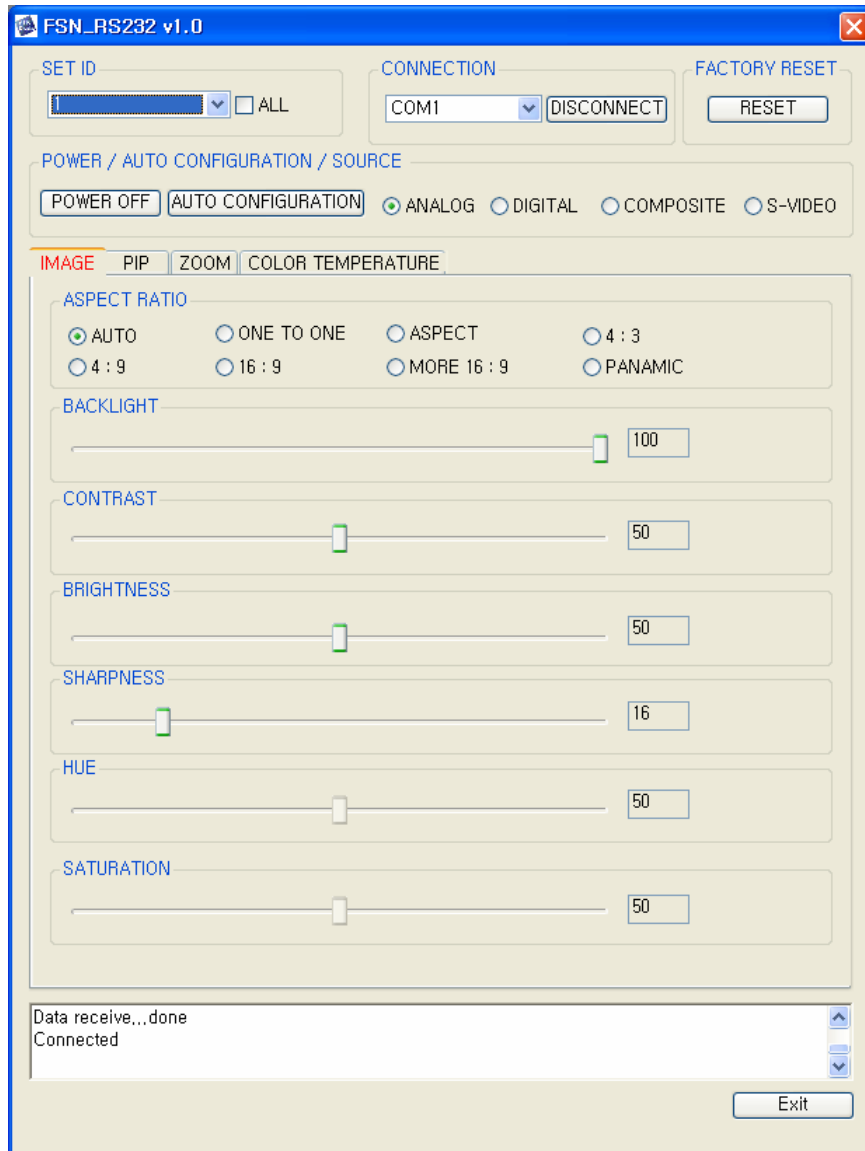

- Aspect Ratio : To adjust the screen format using the aspect ratio control button in the ASPECT RATIO group box (AUTO, ONE TO ONE, ASPECT, 4:3, 4:9, 16:9, MORE 16:9, PANARMIC)
- Backlight : To adjust screen backlight (PWM control)
- Contrast : To adjust screen contrast
- Brightness : To adjust screen brightness
- Sharpness : To adjust screen sharpness
- Hue : To adjust the screen color
- Saturation : To adjust screen tint

8.6 PIP

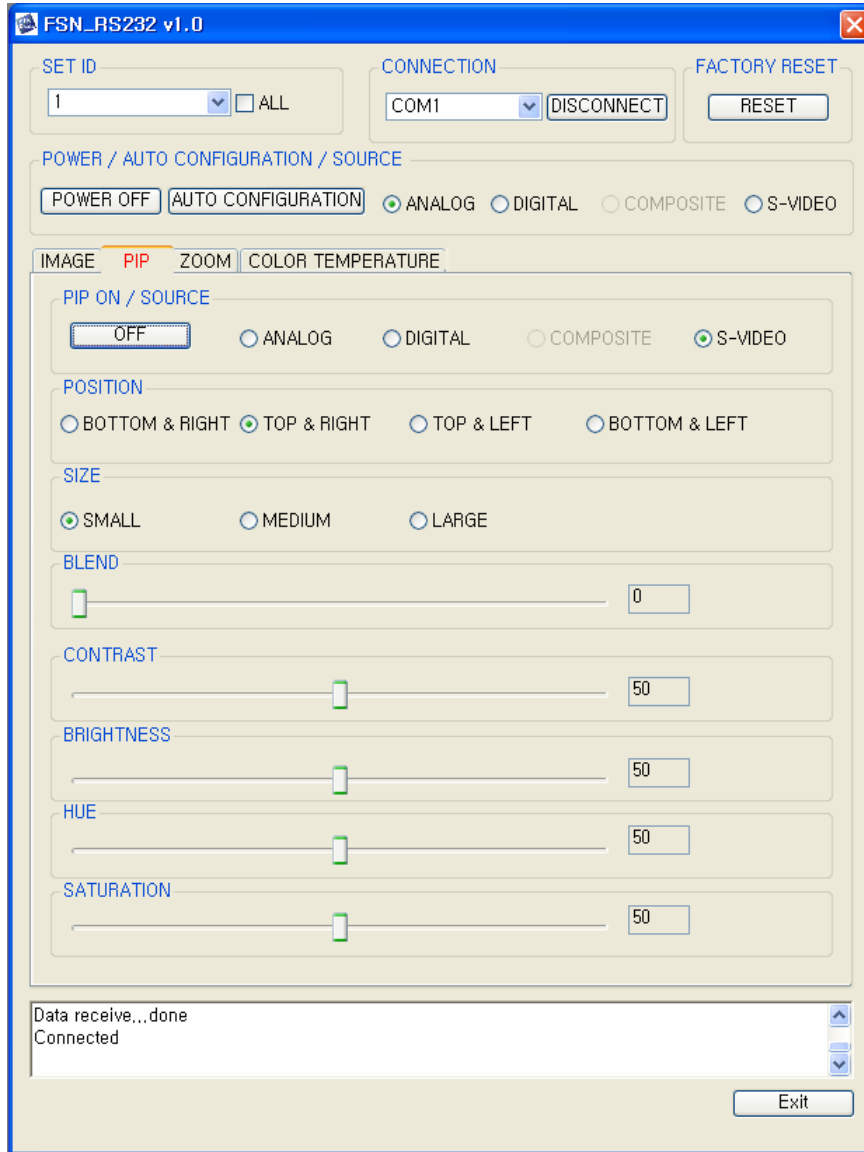

- PIP On/Off button : To control PIP On/Off
- Source : To select an PIP input source using the radio button (ANALOG, DIGITAL, COMPOSITE, S-VIDEO) on the POWER / AUTO CONFIGURATION / SOURCE group box
- Position : To adjust PIP Position (Bottom /Right, Top/Right, Top/Left, Bottom/Left)
- Size : To adjust PIP image size (Small, Medium, Large)
- Blend : To adjust the transparency of PIP image
- Contrast : To adjust PIP window image contrast
- Brightness : To adjust PIP window image brightness
- Sharpness : To adjust PIP window image sharpness
- Hue : To adjust PIP window image color
- Saturation : To adjust PIP window image tint

8.7 ZOOM

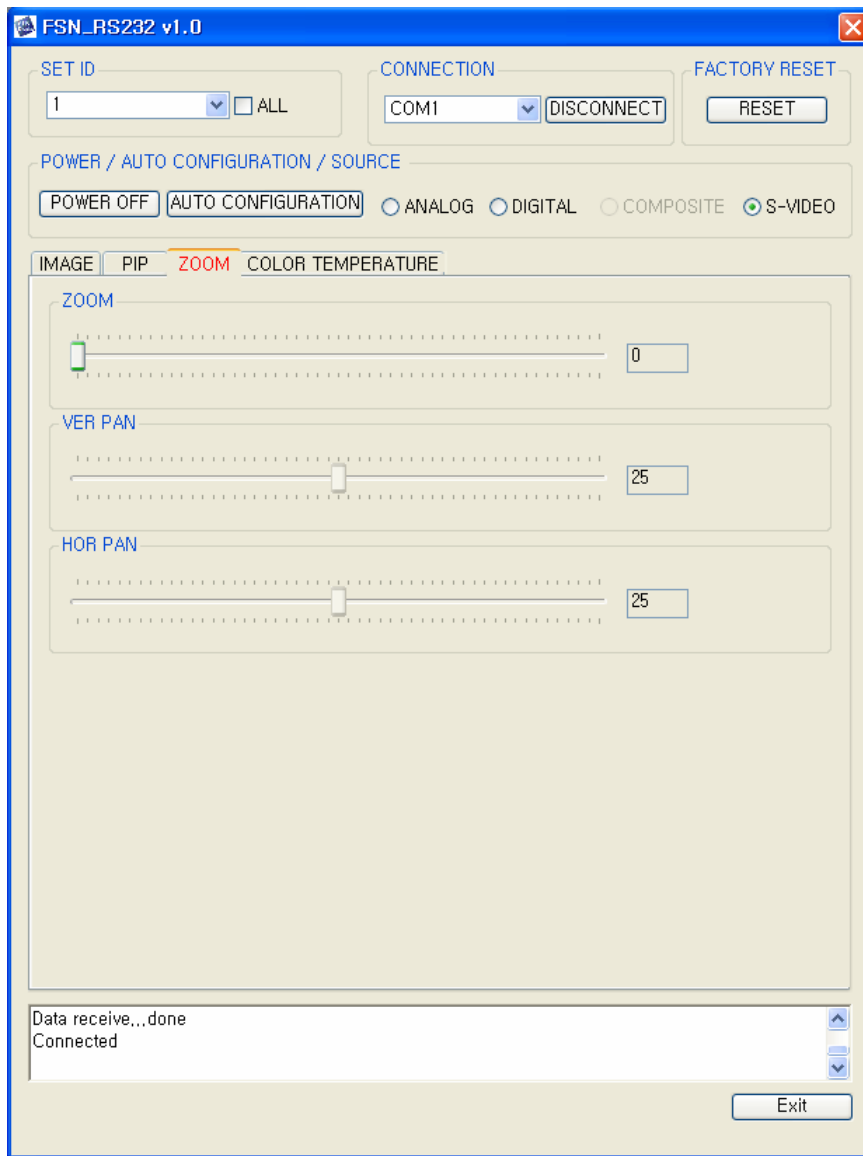

- Zoom : To close up picture
- Ver Pan : It moves vertical image position
- Hor Pan : It moves horizontal image position

8.8 Color Temperature

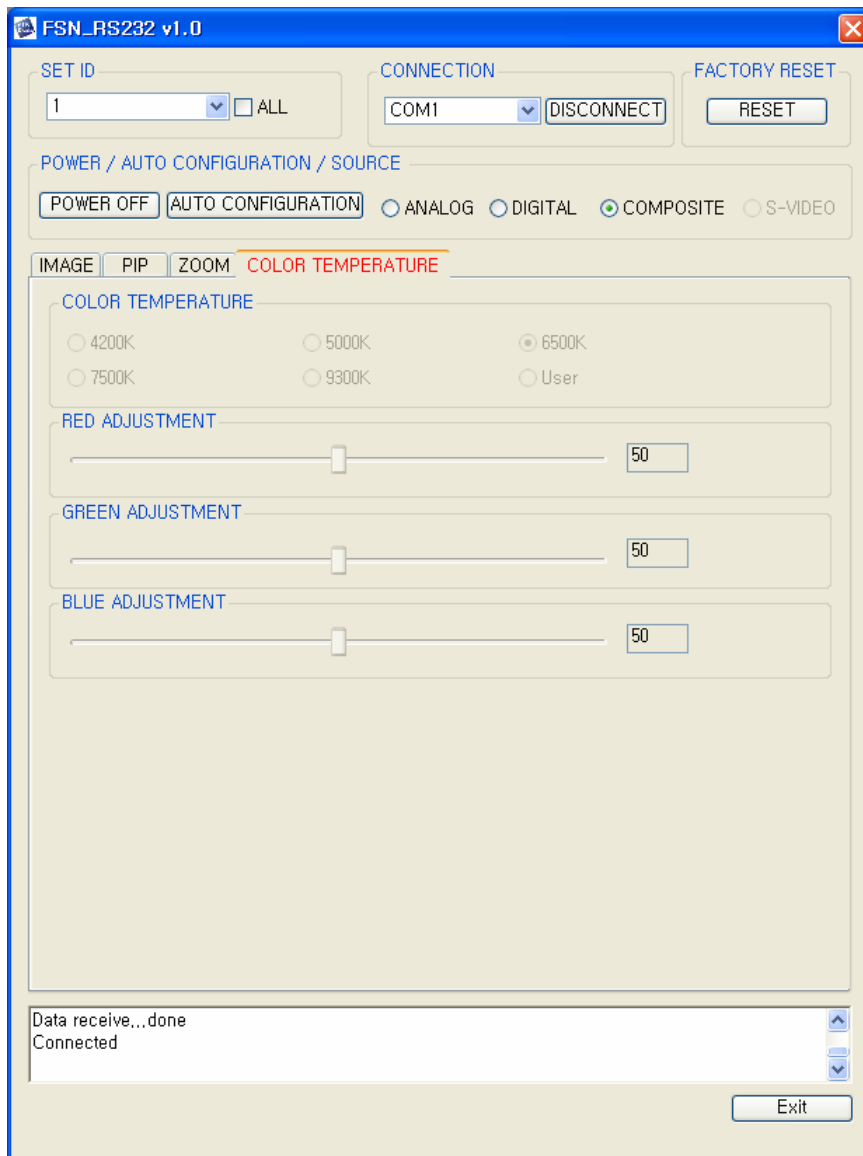

- Color Temperature : To adjust the color temperature
(4200K, 5000K, 6500K, 7500K, 9300K, USER)
- *Red Adjustment : To adjust the Red color
- *Green Adjustment : To adjust the Green color
- *Blue Adjustment : To adjust the Blue color