

■ FEATURES

- Micro power design
- Operation with North or South pole(omni polar)
- 2.4V to 5.5V battery operation
- High sensitivity and high stability of the magnetic switching points
- High resistance to mechanical stress
- Digital output signal
- Good RF noise immunity
- -40°C to 85°C operating temperature
- Programming pin for switching detection of output
- Package: SOT23-6L

■ FUNCTIONAL BLOCK DIAGRAM

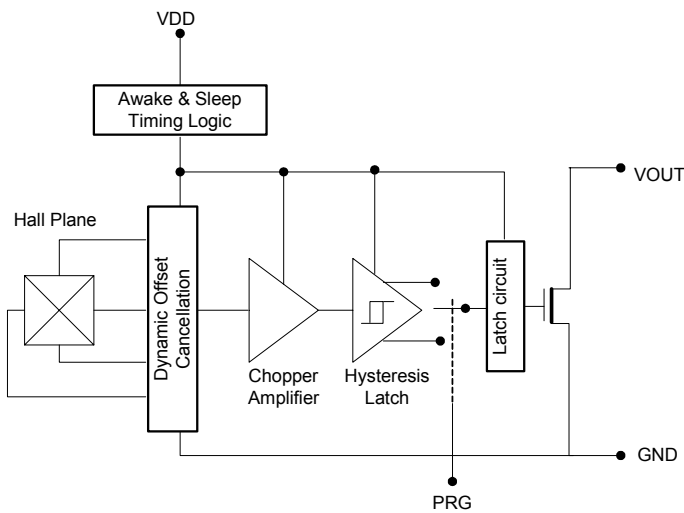

■ GENERAL DESCRIPTION

The FSH4917 is an Integrated Hall Effect Sensor designed specifically to meet the requirements of low-power devices. e.g. as an On/Off switch in Cellular Flip-Phones, with battery operating voltages of 2.4V – 5.5V.

Precise magnetic switching points and high temperature stability are achieved through the unique design of the internal circuit.

An onboard clock scheme is used to reduce the average operating current of the IC.

During the operate phase the IC compares the actual magnetic field detected with the internally compensated switching points. The output is switched at the end of each operating phase.

During the Stand-by phase the output stage is latched and the current consumption of the device reduced to some μA .

The IC switching behavior is Omni polar, i.e. it can be switched on with either the North or South pole of a magnet.

The PRG pin can be connected to V_{DD} which holds the output V_O at a High level for $B=0\text{mT}$; conversely the output V_O can be inverted by connecting the PRG pin to GND, which will hold the output V_O at a Low level for $B=0\text{mT}$. In this later case the presence of an adequate magnetic field will cause the output V_O to switch to a High level (i.e. off state).

■ TYPICAL APPLICATION CIRCUIT

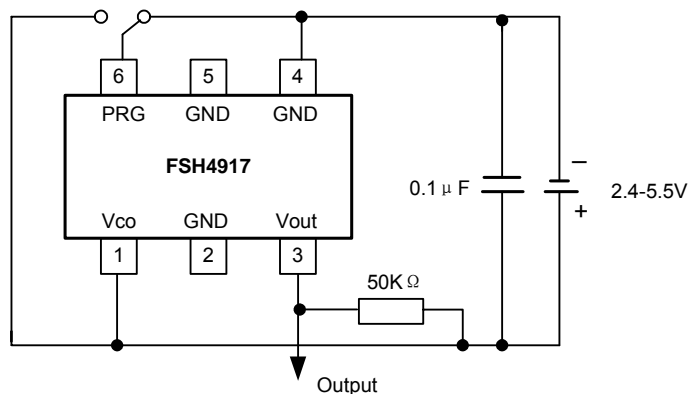

■ PIN CONFIGURATION

(Top View)

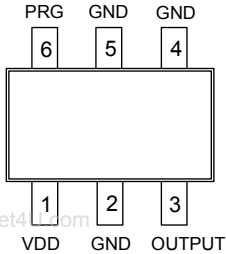

Pin	Symbol	Function
1	VDD	Supply Voltage
2	GND	Ground
3	OUTPUT	Signal Output (Open Drain)
4	GND	Ground
5	GND	Ground
6	PRG	Programming Input

■ ABSOLUTE MAXIMUM RATINGS

Parameter	Symbol	Maximum	Unit
Supply Voltage	V_{DD}	5.5	V
Supply Current	I_{DD}	2.5	mA
Output Voltage	V_O	5.5	V
Output Current	I_O	1	mA
PRG Input voltage	V_{PRG}	5.5	V
Operating Temperature Range	T_{OP}	-40 to 85	°C
Junction Temperature	T_J	-40 to 150	°C
Storage Temperature	T_{STG}	-40 to 150	°C
Magnetic Flux Density	B	unlimited	mT
Power Dissipation	P_D	230	mW

Caution: Stress above the listed absolute maximum rating may cause permanent damage to the device

■ TYPICAL IR SOLDER-REFLOW PROFILE

Lead Temperature (Soldering, 10sec)-----+260°C

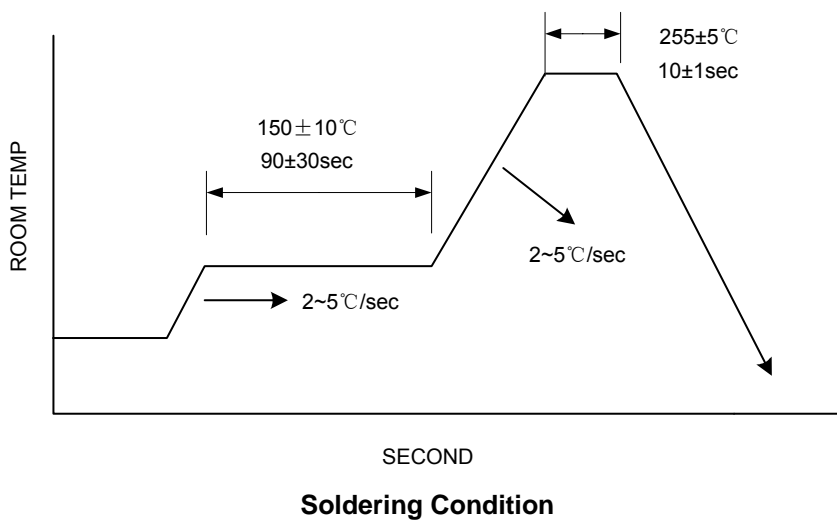

RECOMMENDED OPERATING RANGE

Parameter	Symbol	Min.	Typ.	Max.	Unit
Supply Voltage ¹⁾	V _{DD}	2.4	2.7	5.5	V
Output Voltage	V _O	-0.3	2.7	5.5	V
Ambient Temperature	T _A	-40	25	85	°C

¹⁾ A Ceramic Bypass Capacitor of 0.1uF at V_{DD} to GND is highly recommended.

ELECTRICAL CHARACTERISTICS

Parameter	Symbol	Test Condition	Min.	Typ.	Max.	Unit
Averaged Supply Current	I _{DD(AVG)}		-	3 ¹⁾	20	uA
Supply Current During Operating Time	I _{DD(OP)}		-	1.1 ¹⁾	-	mA
Supply Current During Standby Time	I _{DD(STB)}		-	2.5 ¹⁾	-	uA
Output Saturation Voltage	V _{O(SAT)}	I _O =1mA	-	0.1	0.3	V
Output Leakage Current	I _{O(LEAK)}		-	0.01	1	uA
Operating Time	T _{OP}		-	56	-	us
Standby Time	T _{STB}		-	140	-	ms
Duty Cycle	T _{OP} / T _{STB}		-	0.04	-	%

¹⁾ Operating voltage is 2.7V.

MAGNETIC CHARACTERISTICS

PRG connected to VDD

Parameter	Symbol	Min.	Typ.	Max.	Unit
Operate Points (Output ON)	B _{OPS}	40	55	70	G
	B _{OPN}	-70	-55	-40	G
Release Points (Output OFF)	B _{RPS}	30	45	60	G
	B _{RPN}	-60	-45	-30	G
Hysteresis	B _{HYS}	5	10	15	G

PRG connected to GND

Parameter	Symbol	Min.	Typ.	Max.	Unit
Operate Points (Output ON)	B _{OPS}	30	45	60	G
	B _{OPN}	-60	-45	-30	G
Release Points (Output OFF)	B _{RPS}	40	55	70	G
	B _{RPN}	-70	-55	-40	G
Hysteresis	B _{HYS}	5	10	15	G

Note: If not other specified, typical characteristics apply at T_A = 25 °C and V_{DD} = 2.7 V

■ **TIMING DIAGRAM**

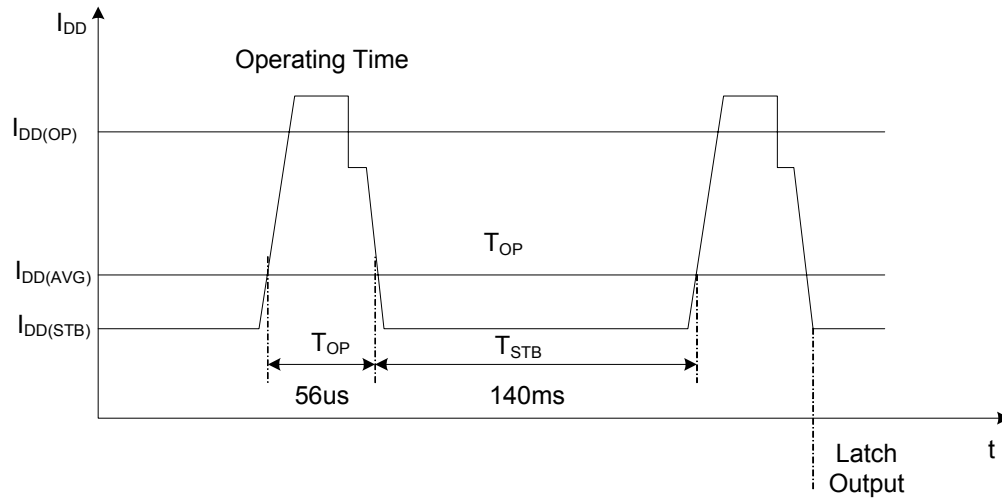

■ **PROGRAMMING OF OUTPUT WITH PRG PIN**

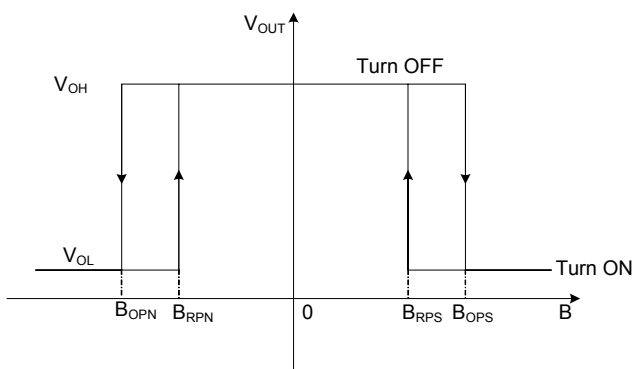

PRG connected to VDD

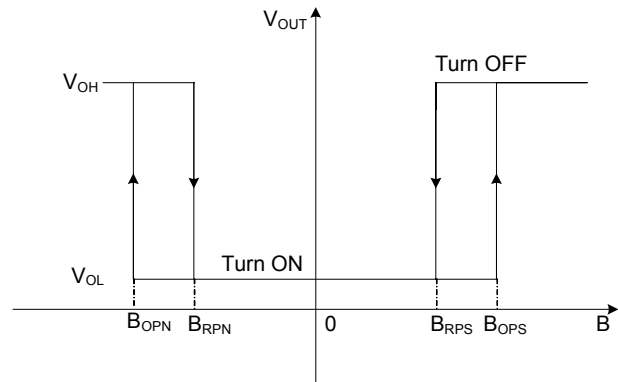

PRG connected to GND

■ TYPICAL PERFORMANCE CHARACTERISTICS

Magnetic switching points versus temperature (VDD=2.7V)

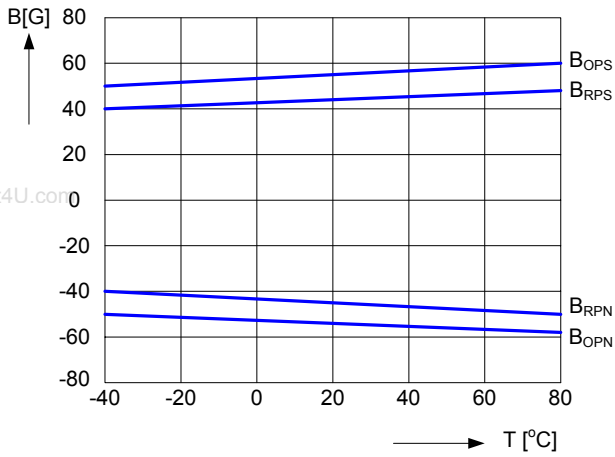

Magnetic switching points versus supply voltage

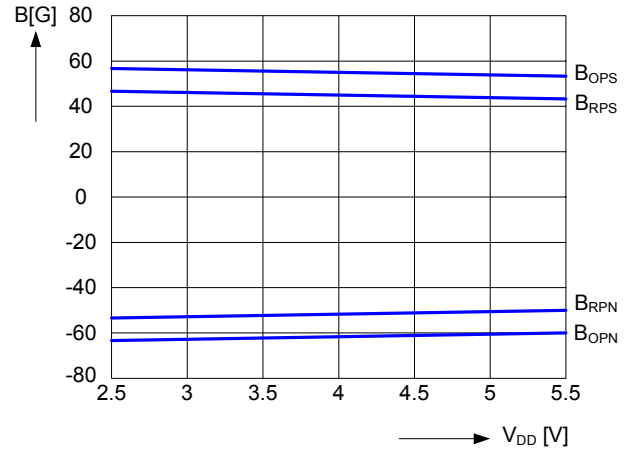

Average current versus supply voltage

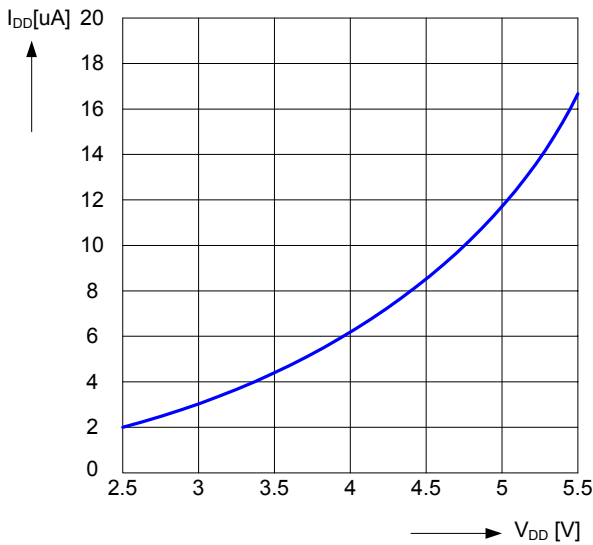

Average current versus temperature (VDD=2.7V)

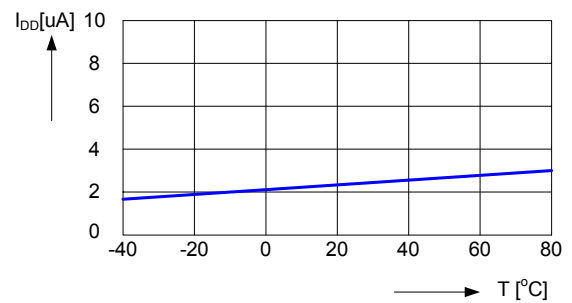

■ ORDERING INFORMATION

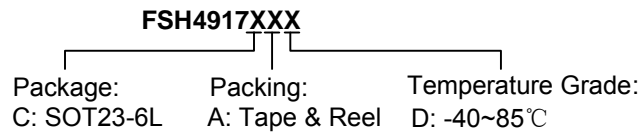

■ MARKING INFORMATION

www.DataSheet4U.com

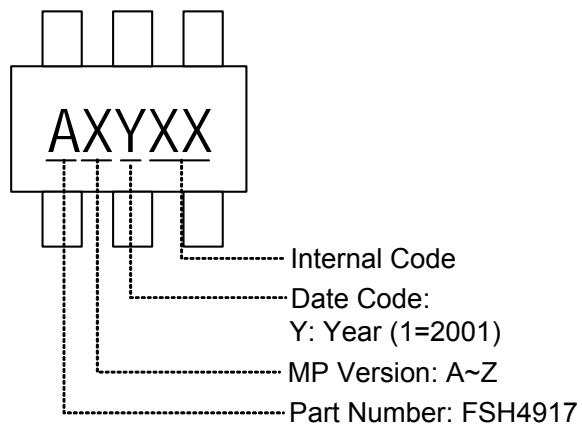

■ PACKAGE INFORMATION

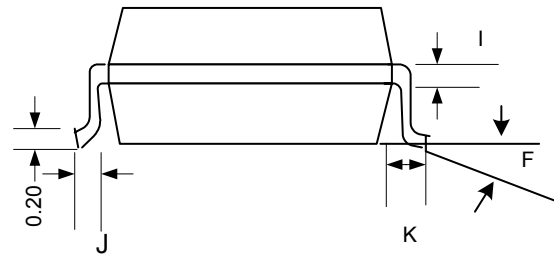
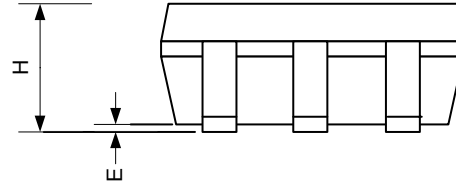
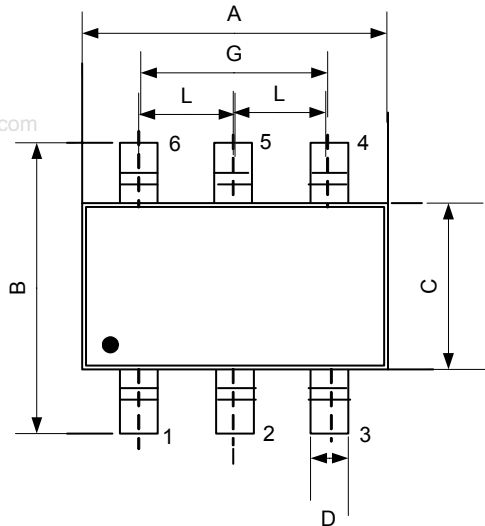

Symbol	Dimensions In Millimeters			Dimensions In Inches		
	Min.	Nom.	Max.	Min.	Nom.	Max.
A		2.90 Ref.			0.114 Ref.	
B		2.80 Ref.			0.110 Ref.	
C		1.60 Ref.			0.063 Ref.	
D	0.30		0.50	0.012		0.020
E			0.15			0.006
F	0°	4°	8°	0°	4°	8°
G		1.90 Ref.			0.075 Ref.	
H	1.10	1.20	1.30	0.044	0.048	0.052
I	0.08		0.22	0.003		0.009
J	0.30	0.45	0.60	0.012	0.018	0.024
K		0.60 Ref.			0.024 Ref.	
L		0.95 Ref.			0.037 Ref.	

■ **PACKING INFORMATION**

1) Embossed Plastic Tape

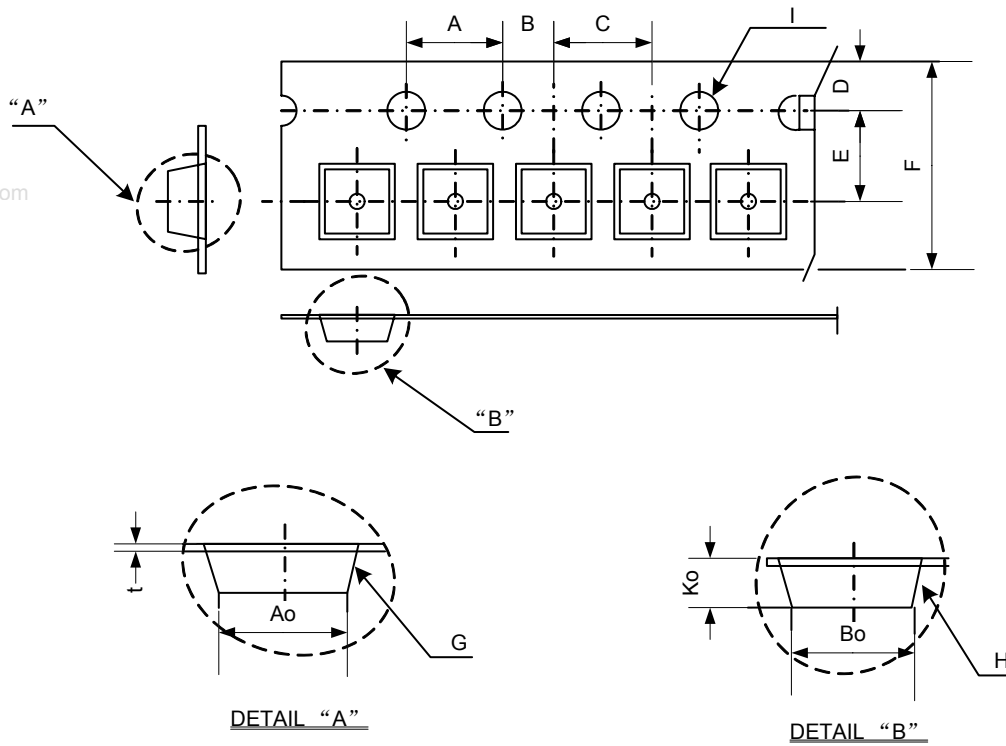

Model	Dimension (mm)						
	A	B	C	D	E	F	I
FSH4917	4.00±0.1	2.00±0.05	4.00±0.1	1.75±0.1	3.50±0.05	8.00±0.3	Φ1.50±0.1

Model	Dimension (mm)					
	G	H	Ao	Bo	Ko	t
FSH4917	MAX. 3°	MAX. 3°	3.20±0.1	3.15±0.1	1.40±0.05	0.20±0.03

2) Taping Size

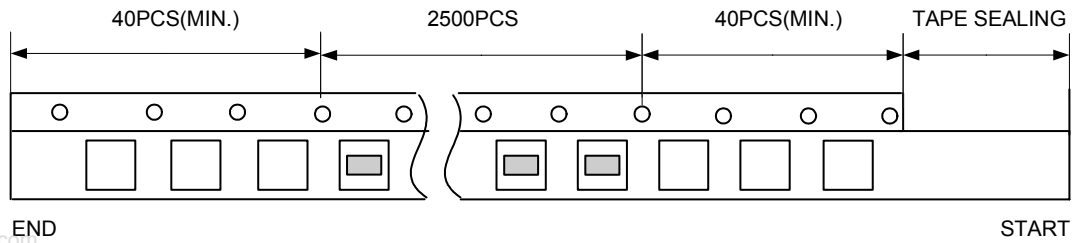

unit: pcs

Model	Symbol	Taping Count	Packing Tape
FSH4917	5" Reel	2500	Embossed Plastic Tape

3) Reel Dimension

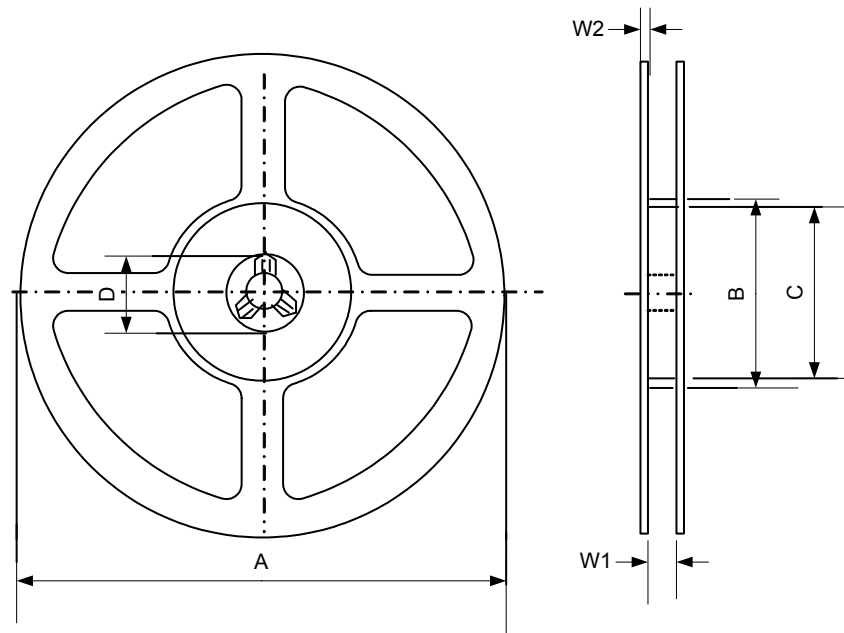

unit: mm

Model	Reel	A	B	C	D	W1	W2
FSH4917	5"	$\Phi 178 \pm 1.0$	$\Phi 72.0 \pm 1.0$	$\Phi 62.0 \pm 1.0$	$\Phi 58.0 \pm 0.2$	8.4 ± 1.0	1.5 ± 0.3

Packing Type: 2500 EA / REEL, 5 REEL / BOX