

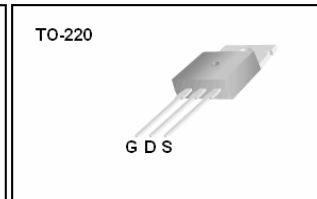
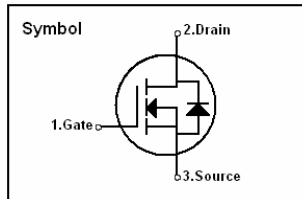


# FSP5N60/FS5N60

## 600V N-Channel MOSFET

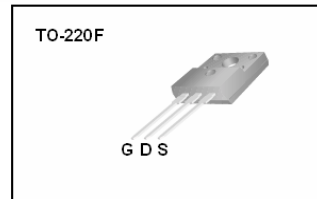
### Features

- 4.5A,600v,RDS(on)=2.2Ω@VGS=10V
- Gate charge (Typical 17nC)
- High ruggedness
- Fast switching
- 100% Avalanche Tested
- Improved dv/dt capability



### General Description

This Power MOSFET is produced using Faircard's advanced planar stripe, DMOS technology. This latest technology has been especially designed to minimize on-state resistance, have a high rugged avalanche characteristics, such as fast switching time, low on resistance, low gate charge and especially excellent avalanche characteristics. This power MOSFET is usually used at AC adaptors, on the battery charger and SMPS



### Absolute Maximum Ratings

Symbol	Parameter	FSP5N60	FS5N60	Units
VDSS	Drain to Source Voltage	600		V
ID	Continuous Drain Current(@TC = 25°C)	4.5	4.5	A
	Continuous Drain Current(@TC = 100°C)	2.7	2.7	A
IDM	Drain Current Pulsed (Note 1)	18	18	A
VGS	Gate to Source Voltage	±30		V
EAS	Single Pulsed Avalanche Energy (Note 2)	280		mJ
EAR	Repetitive Avalanche Energy (Note 1)	13		mJ
dv/dt	Peak Diode Recovery dv/dt (Note 3)	4.5		V/ns
PD	Total Power Dissipation(@TC = 25 °C)	120	45	W
	Derating Factor above 25 °C	0.8	0.5	W/ °C
TSTG, TJ	Operating Junction Temperature & Storage Temperature	-55 ~ 150		°C
TL	Maximum Lead Temperature for soldering purpose, 1/8 from Case for 5 seconds.	300		°C

### Thermal Characteristics

Symbol	Parameter	FSP5N60	FS5N60	Units
RθJC	Thermal Resistance, Junction-to-Case	1.25	3.79	°C/W
RθCS	Thermal Resistance, Case-to-Sink Typ	0.5	0.5	°C/W
RθJA	Thermal Resistance, Junction-to-Ambient	62.5	62.5	°C/W

# FSP5N60/FS5N60

## Electrical Characteristics ( TC = 25 °C unless otherwise noted )

Symbol	Parameter	Test Conditions	Min	Typ	Max	Units
<b>Off Characteristics</b>						
BV <sub>DSS</sub>	Drain-Source Breakdown Voltage	V <sub>GS</sub> = 0V, I <sub>D</sub> = 250uA	600	-	-	V
BV <sub>DSS</sub> T <sub>J</sub>	Breakdown Voltage Temperature coefficient	I <sub>D</sub> = 250uA, referenced to 25 °C	-	0.4	-	V/°C
I <sub>DSS</sub>	Drain-Source Leakage Current	V <sub>DS</sub> = 600V, V <sub>GS</sub> = 0V	-	-	10	uA
		V <sub>DS</sub> = 480V, T <sub>C</sub> = 125 °C	-	-	100	uA
I <sub>GSS</sub>	Gate-Source Leakage, Forward	V <sub>GS</sub> = 30V, V <sub>DS</sub> = 0V	-	-	100	nA
	Gate-source Leakage, Reverse	V <sub>GS</sub> = -30V, V <sub>DS</sub> = 0V	-	-	-100	nA
<b>On Characteristics</b>						
V <sub>GS(th)</sub>	Gate Threshold Voltage	V <sub>DS</sub> = V <sub>GS</sub> , I <sub>D</sub> = 250uA	2.0	-	4.0	V
R <sub>DS(ON)</sub>	Static Drain-Source On-state Resistance	V <sub>GS</sub> = 10 V, I <sub>D</sub> = 2.25A	-	2.0	2.2	
<b>Dynamic Characteristics</b>						
C <sub>iss</sub>	Input Capacitance	V <sub>GS</sub> = 0 V, V <sub>DS</sub> = 25V, f = 1MHz	-	545	780	pF
C <sub>oss</sub>	Output Capacitance		-	35	80	
C <sub>rss</sub>	Reverse Transfer Capacitance		-	8	11	
<b>Dynamic Characteristics</b>						
t <sub>d(on)</sub>	Turn-on Delay Time	V <sub>DD</sub> = 300V, I <sub>D</sub> = 4.5A, R <sub>G</sub> = 25 (Note 4, 5)	-	10	30	ns
t <sub>r</sub>	Rise Time		-	35	80	
t <sub>d(off)</sub>	Turn-off Delay Time		-	45	100	
t <sub>f</sub>	Fall Time		-	40	90	
Q <sub>g</sub>	Total Gate Charge	V <sub>DS</sub> = 480V, V <sub>GS</sub> = 10V, I <sub>D</sub> = 4.0A (Note 4, 5)	-	17	20	nC
Q <sub>gs</sub>	Gate-Source Charge		-	2.8	-	
Q <sub>gd</sub>	Gate-Drain Charge(Miller Charge)		-	6.2	-	

## Source-Drain Diode Ratings and Characteristics

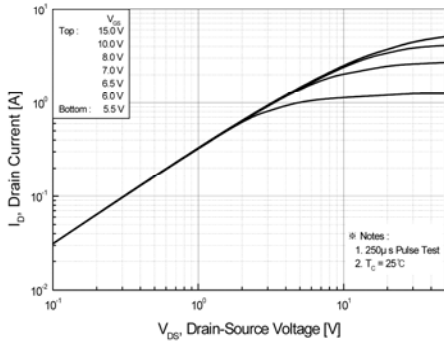
Symbol	Parameter	Test Conditions	Min.	Typ.	Max.	Unit.
I <sub>S</sub>	Continuous Source Current	Integral Reverse p-n Junction	-	-	4.0	A
I <sub>SM</sub>	Pulsed Source Current	Diode in the MOSFET	-	-	16	
V <sub>SD</sub>	Diode Forward Voltage	I <sub>S</sub> = 4.5A, V <sub>GS</sub> = 0V	-	-	1.4	V
t <sub>rr</sub>	Reverse Recovery Time	I <sub>S</sub> = 4.5A, V <sub>GS</sub> = 0V, di/dt = 100A/us	-	300	-	ns
Q <sub>rr</sub>	Reverse Recovery Charge	I <sub>S</sub> = 4.5A, V <sub>GS</sub> = 0V, di/dt = 100A/us	-	2.2	-	uC

### NOTES

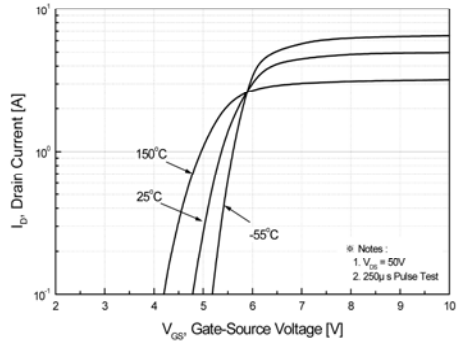
1. Repeatability rating : pulse width limited by junction temperature
2. L = 27.5mH, I<sub>AS</sub> = 4.5A, V<sub>DD</sub> = 50V, R<sub>G</sub> = 25 Ω, Starting T<sub>J</sub> = 25°C
3. I<sub>SD</sub> = 4.5A, di/dt = 200A/us, V<sub>DD</sub> = BV<sub>DSS</sub>, Starting T<sub>J</sub> = 25°C
4. Pulse Test : Pulse Width = 300us, Duty Cycle = 2%
5. Essentially independent of operating temperature

# FSP5N60/FS5N60

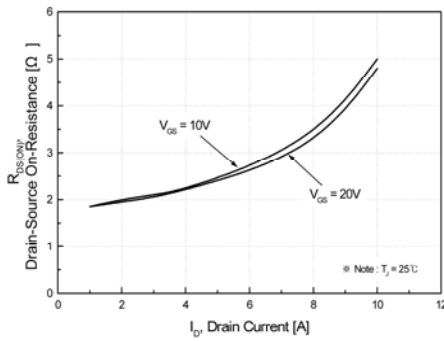
**Fig 1. On-State Characteristics**



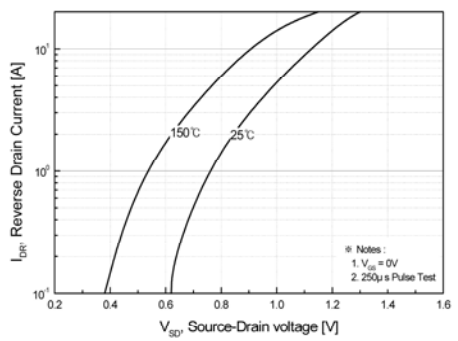
**Fig 2. Transfer Characteristics**



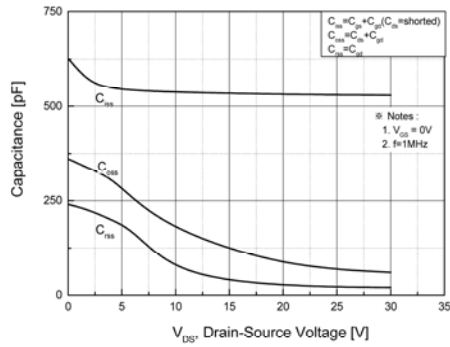
**Fig 3. On Resistance Variation vs. Drain Current and Gate Voltage**



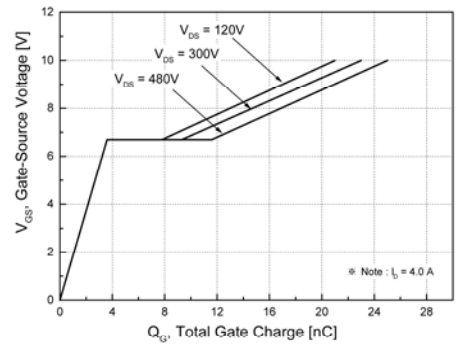
**Fig 4. On State Current vs. Allowable Case Temperature**



**Fig 5. Capacitance Characteristics (Non-Repetitive)**

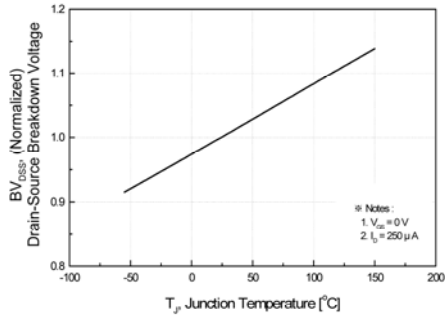


**Fig 6. Gate Charge Characteristics**

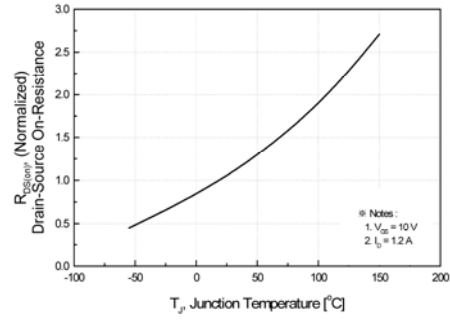


# FSP5N60/FS5N60

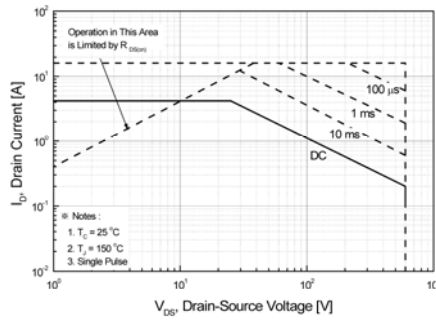
**Fig 7. Breakdown Voltage Variation vs. Junction Temperature**



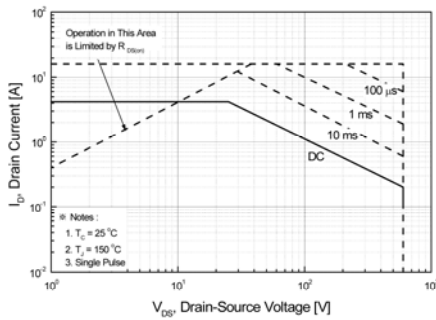
**Fig 8. On-Resistance Variation vs. Junction Temperature**



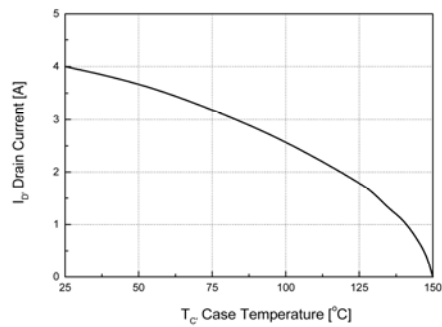
**Fig 9-1. Maximum Safe Operating Area for FSP5N60**



**Fig 9-2. Maximum Safe Operating Area for FS5N60**



**Fig 10. Maximum Drain Current vs. Case Temperature**



# FSP5N60/FS5N60

Fig 11-1. Transient Thermal Response Curve for FSP5N60

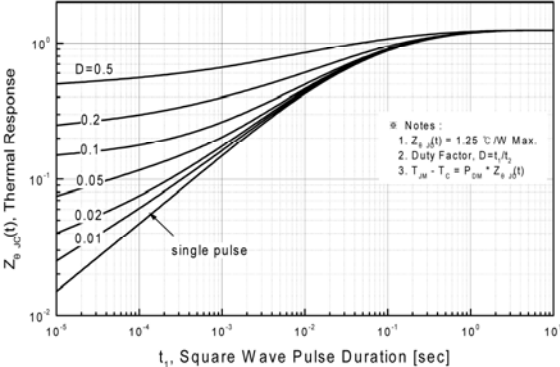
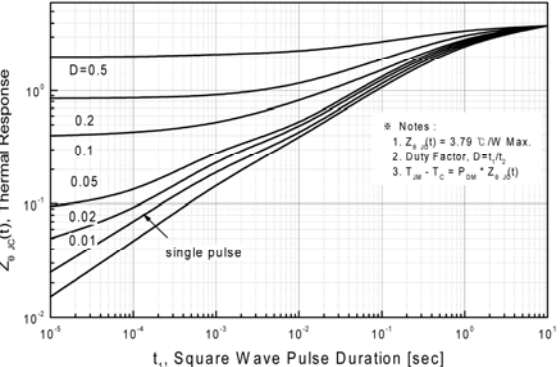


Fig 11-2 . Transient Thermal Response Curve for FS5N60



# FSP5N60/FS5N60

Fig. 12. Gate Charge Test Circuit & Waveforms

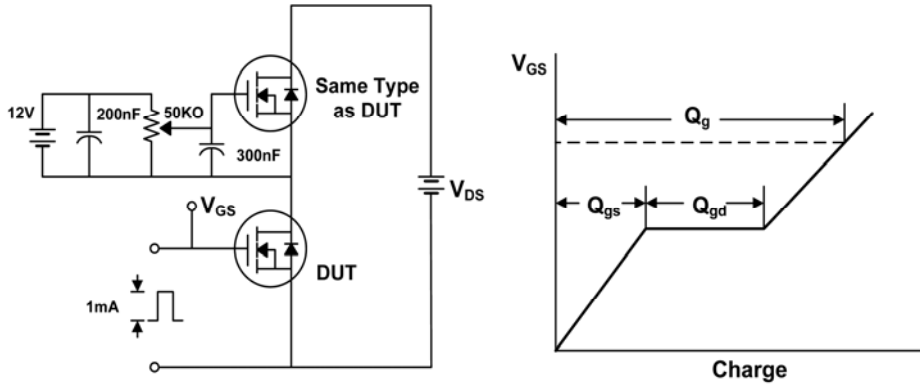


Fig. 13. Switching Time Test Circuit & Waveforms

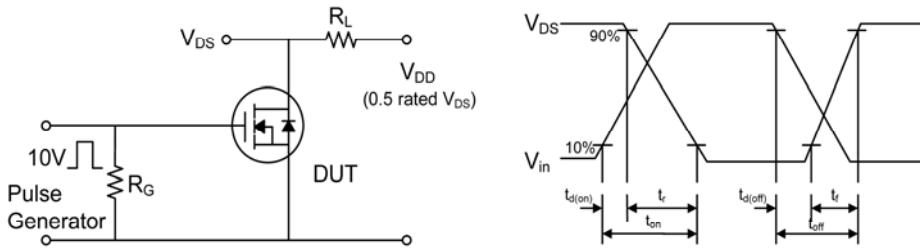


Fig. 14. Unclamped Inductive Switching Test Circuit & Waveforms

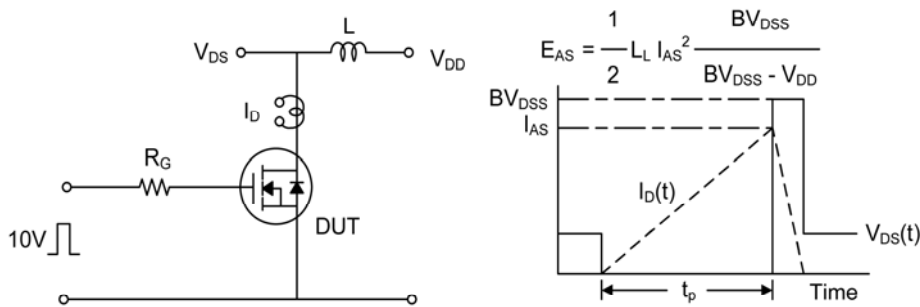
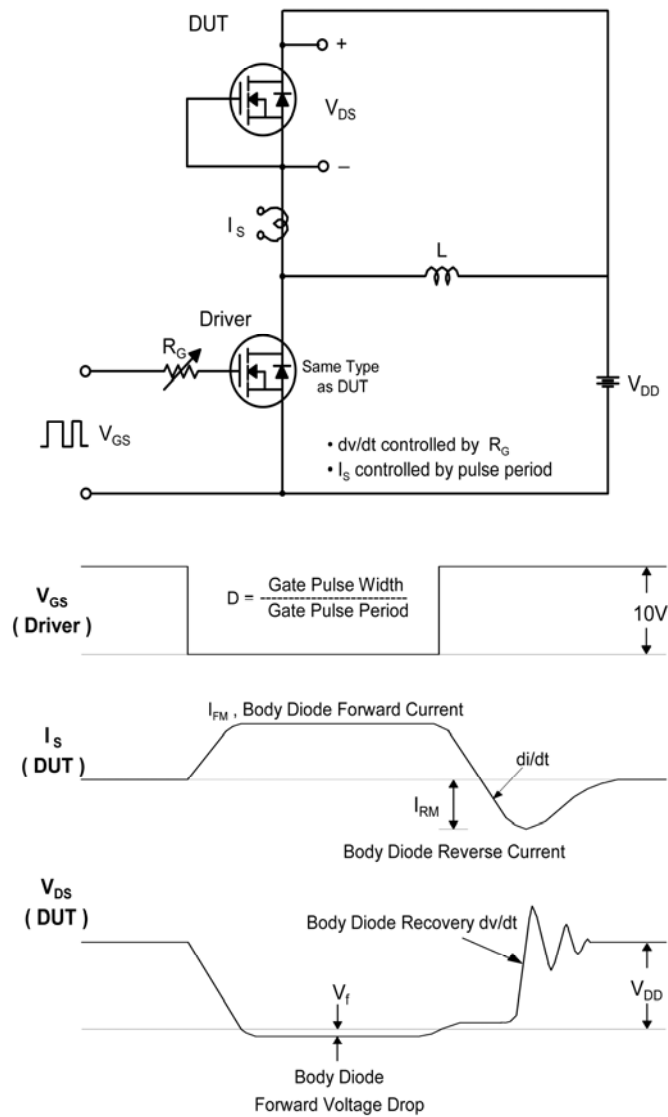


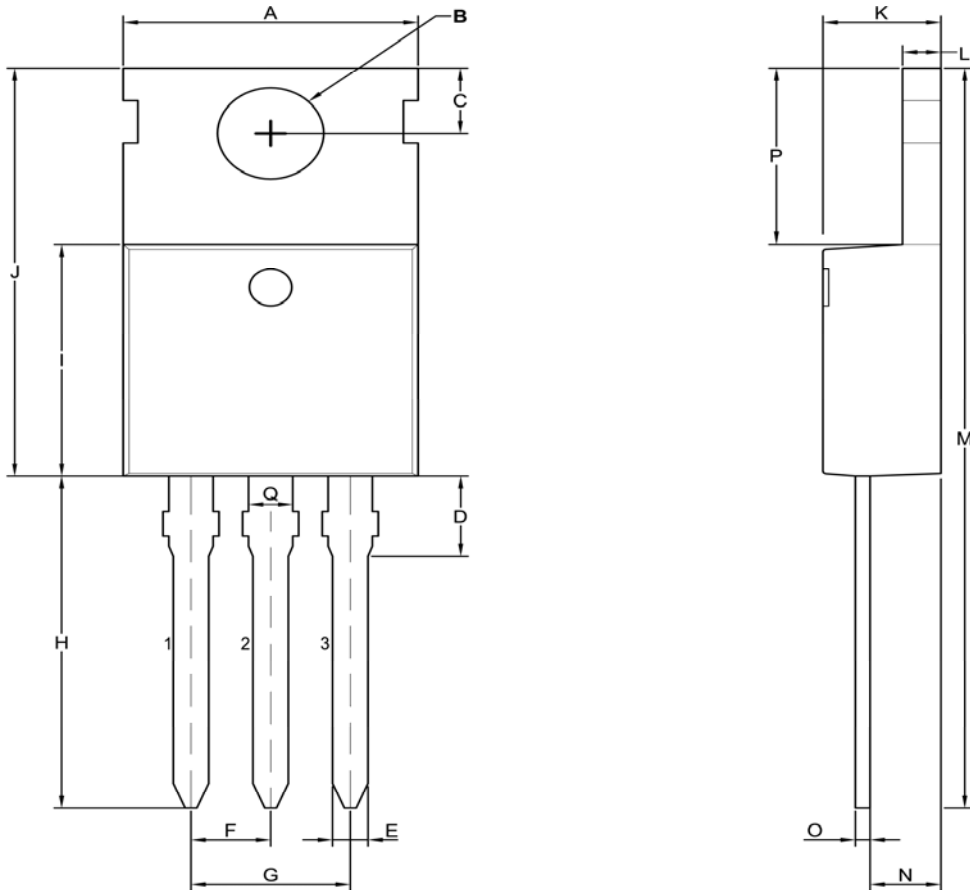
Fig. 15. Peak Diode Recovery dv/dt Test Circuit & Waveforms



# FSP5N60/FS5N60

## Package Dimensions

### TO-220



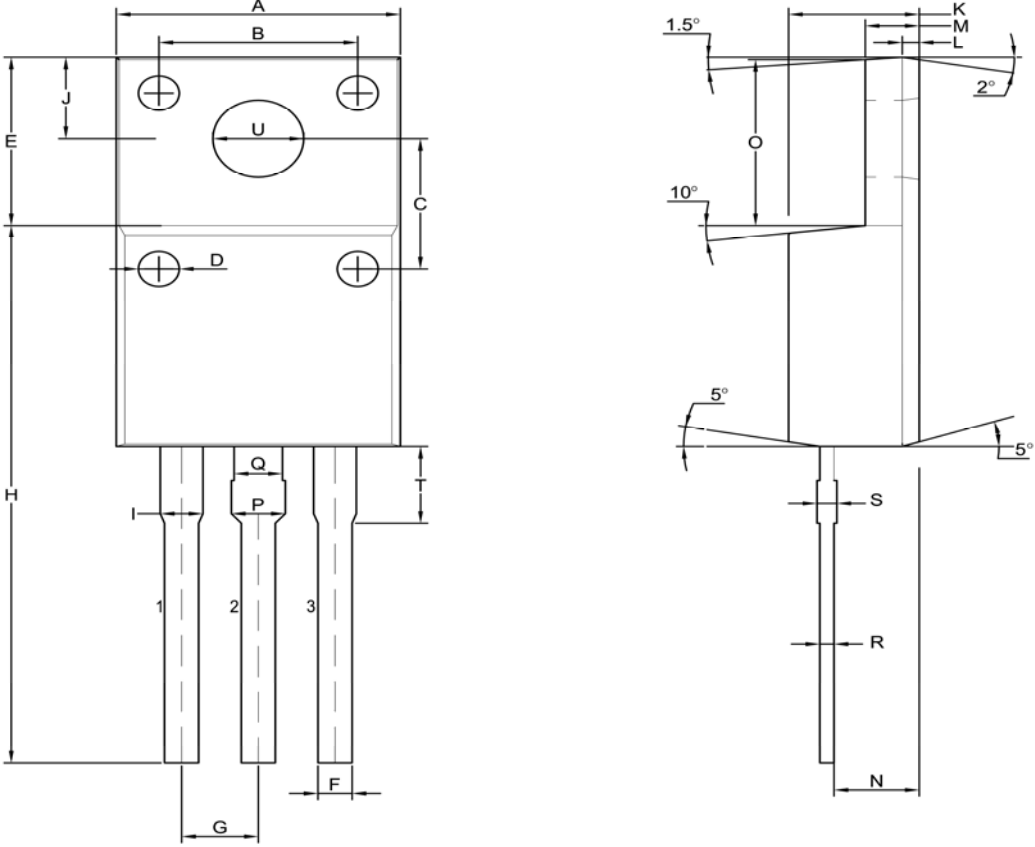
TO-220 DIMENSION			
Symbol	Dimensions in Millimeters		
	Min	Max	Typ
A	10.10	10.35	10.25
B	3.75	3.85	3.80
C	2.50	2.90	2.75
D	3.70	4.50	4.10
E	0.70	0.90	0.80
F	—	—	2.54
G	—	—	5.08
H	13.50	14.20	13.80
I	8.50	9.00	8.80
J	14.80	15.20	15.00
K	4.50	4.58	4.54
L	1.28	1.36	1.32
M	28.60	29.10	28.90
N	2.40	2.90	2.65
O	0.38	0.45	0.40
P	6.20	6.60	6.40
Q	1.30	1.45	1.40



# FSP5N60/FS5N60

## Package Dimensions

### TO-220F



TO-220F DIMENSION			
Symbol	Dimensions In Millimeters		
	Min	Max	Typ
A	9.95	10.10	10.00
B		6.50(typ)	6.5
C		5.95(typ)	5.95
D		∅ 1.40(typ)	∅ 1.40
E	15.10	15.30	15.20
F	0.55	0.70	0.60
G	2.35	2.73	2.54
H	13.35	13.55	13.40
I	1.11	1.45	1.20
J	2.90	3.10	3.00
K	4.45	4.55	4.50
L		1.15(typ)	1.15
M		3.10(typ)	3.10
N	2.60	2.80	2.70
O	6.80	7.10	6.95
P	1.64	1.70	—
Q	1.48	1.66	1.58
R	0.60	0.68	—
S	0.62	0.78	—
T	3.60	3.90	3.75
U	3.00	3.20	—