

Schottky Barrier Rectifier

FST3050

FEATURES

- With TO-247 packaging
- Low leakage current
- Low power loss
- High efficiency
- High surge capacity
- Guarding for overvoltage protection
- 100% avalanche tested
- Minimum Lot-to-Lot variations for robust device performance and reliable operation

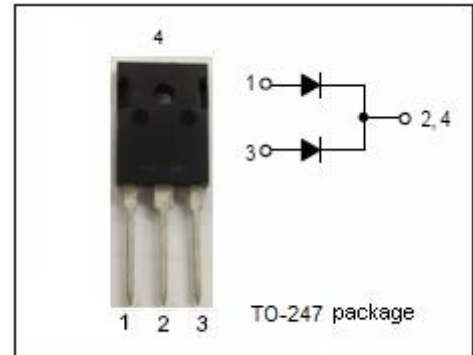

APPLICATIONS

- Designed for designed for low-voltage,high frequency inverters, free wheeling and polarity protection applications .

ABSOLUTE MAXIMUM RATINGS($T_a=25^{\circ}\text{C}$)

SYMBOL	PARAMETER	VALUE	UNIT
V_{RRM} V_{RWM} V_R	Peak Repetitive Reverse Voltage Working Peak Reverse Voltage DC Blocking Voltage	50	V
$I_{F(AV)}$	Average Rectified Forward Current Per Leg @ $T_c=157^{\circ}\text{C}$	30	A
I_{FSM}	Nonrepetitive Peak Surge Current (Surge applied at rated load conditions half-wave, single phase, 60Hz) @ $T_j=175^{\circ}\text{C}$	350	A
T_J	Junction Temperature	175	$^{\circ}\text{C}$
T_{stg}	Storage Temperature Range	-55~175	$^{\circ}\text{C}$

THERMAL CHARACTERISTICS

SYMBOL	PARAMETER	MAX	UNIT
R_{th-j-c}	Thermal Resistance, Junction to Case	0.9	$^{\circ}\text{C}/\text{W}$

Schottky Barrier Rectifier

FST3050

ELECTRICAL CHARACTERISTICS($T_a=25^{\circ}\text{C}$) (Pulse Test: Pulse Width=300 μ s,Duty Cycle \leq 2%)

SYMBOL	PARAMETER	CONDITIONS	MAX	UNIT
V_F	Maximum Instantaneous Forward Voltage	$I_F=15\text{A};T_J=25^{\circ}\text{C}$ $I_F=15\text{A};T_J=125^{\circ}\text{C}$	0.66 0.50	V
I_R	Maximum Instantaneous Reverse Current	$V_{RRM}=50\text{V};T_J=25^{\circ}\text{C}$ $V_{RRM}=50\text{V};T_J=125^{\circ}\text{C}$	0.5 15	mA

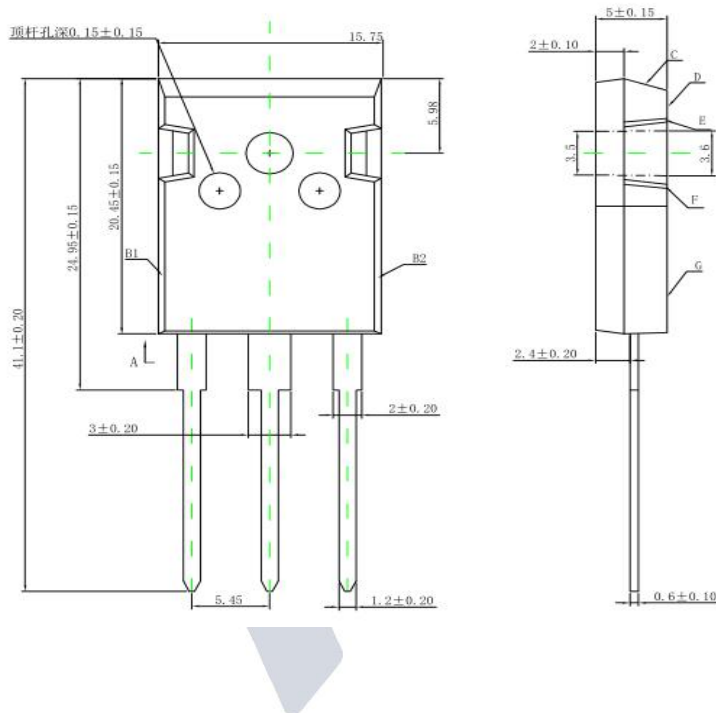
NOTICE:

ISC reserves the rights to make changes of the content herein the datasheet at any time without notification. The information contained herein is presented only as a guide for the applications of our products.

ISC products are intended for usage in general electronic equipment. The products are not designed for use in equipment which require specialized quality and/or reliability, or in equipment which could have applications in hazardous environments, aerospace industry, or medical field. Please contact us if you intend our products to be used in these special applications.

ISC makes no warranty or guarantee regarding the suitability of its products for any particular purpose, nor does ISC assume any liability arising from the application or use of any products, and specifically disclaims any and all liability, including without limitation special, consequential or incidental damages.

