

Three Phase Sensorless BLDC Motor Controller

Description

The FT3106 is a Three Phase sensorless BLDC Motor controller. Due to its adaptive features and wide power-supply range capabilities, it is intended to cover a wide range of motor characteristics, while requiring minimal tuning from the user. Speed adjustment can be achieved through either direct-PWM or analog voltage control. Speed indicator is provided through a Frequency Generator output, generating digital pulse with its frequency proportional to the speed of the motor.

Protection functions of FT3106 are comprehensive including lock protection and automatic recovery, under voltage, thermal shutdown, current limit and over current protections. These prevent the control circuits and the

motor from being damaged, particularly under stressed applications and demanding environments.

Feature

- Position sensorless BLDC controller
- Two speed adjustment methods can be selected (direct-PWM and analog voltage control)
- Lead angle control
- FG (Frequency Generator)
- Current limit and over current protection
- Built-in lock protection and automatic recovery circuit
- Built-in thermal shutdown protection (TSD)
- Built-in under voltage lock out protection. (UVLO)
- Built-in over voltage protection of motor driver

Block Diagram

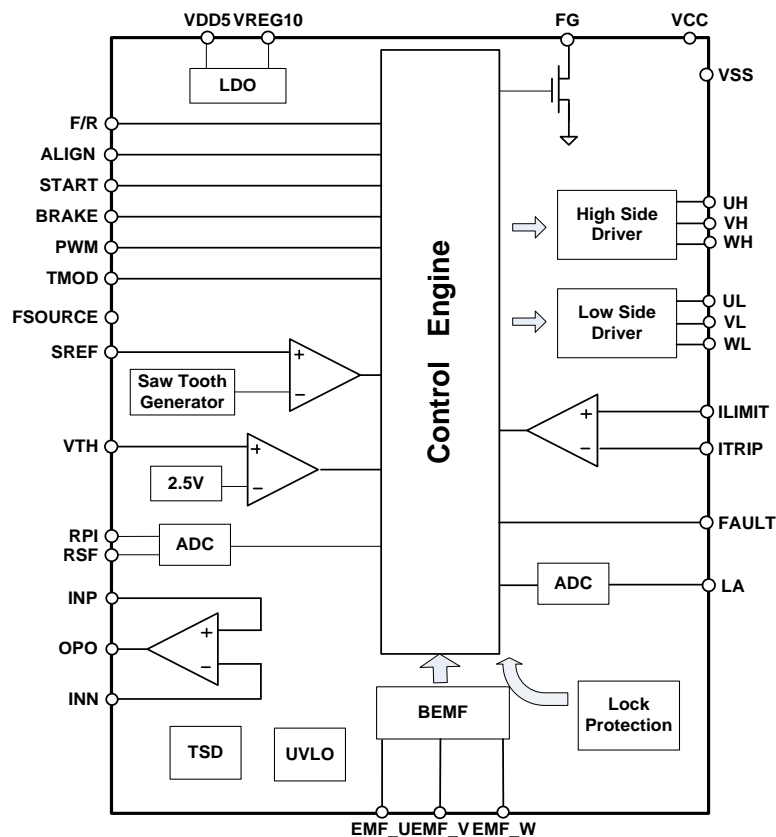

Pin Assignment

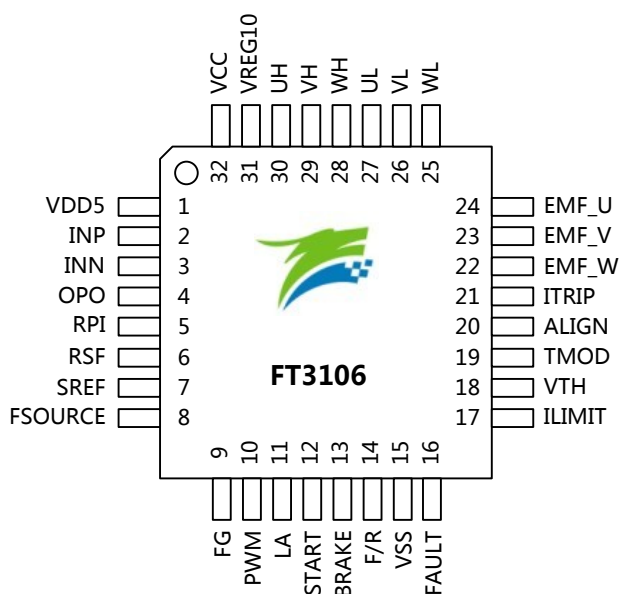

Pin Configuration

PIN NO.	PIN Name	Type	Description
1	VDD5	O	Digital power output, LDO DC5V output for digital signal.
2	INP	I	The positive input of the operational amplifier
3	INN	I	The negative input of the operational amplifier
4	OPO	O	The output of the operational amplifier
5	RPI	I	Initial PWM duty cycle analog input
6	RSF	I	Initial starting frequency analog input
7	SREF	I	Analog input voltage for speed adjustment.
8	FSOURCE	I	Test signal input, connect to GND.
9	FG	O	Open drain. Frequency Generator, speed signal output.
10	PWM	I	PWM input for speed adjustment. Internal pull-up
11	LA	I	Lead angle select analog input
12	START	I	Motor start input. High: Start; Low: Free. Internal pull-up
13	BRAKE	I	Brake signal input, Low: Brake. Internal pull-up.
14	F/R	I	Motor rotation direction input
15	VSS	GND	Signal and power ground.
16	FAULT	I	Over current protection input. Internal pull-up
17	ILIMIT	I	Current limit analog input
18	VTH	I	Over-temperature protection
19	TMOD	I	Digital input, test mode select.
20	ALIGN	I	Choose whether to align the rotor to a known position at first. High: Aligned; Low: Unaligned

PIN NO	PIN Name	Type	Description
21	ITRIP	I	Current sensor voltage feedback analog input
22	EMF_W	I	Phase W back EMF.
23	EMF_V	I	Phase V back EMF.
24	EMF_U	I	Phase U back EMF.
25	WL	O	Low side phase W NMOS driver
26	VL	O	Low side phase V NMOS driver
27	UL	O	Low side phase U NMOS driver
28	WH	O	High side phase W PMOS driver
29	VH	O	High side phase V PMOS driver
30	UH	O	High side phase U PMOS driver
31	VREG10	O	LDO output
32	VCC	POWER	Power supply

Absolute Maximum Ratings

Stresses exceeding the absolute maximum ratings may damage the device. The device may be damaged or may not function or be operational above these ratings and stressing the device to/above these levels is not recommended. Fortior does not recommend exceeding or designing about the Absolute Maximum Ratings.

Parameter	Symbol	Condition	Ratings	Unit
Power supply voltage	V_{CCmax}		30.0	V
FG output current	I_{FGmax}		10	mA
Operating temperature	T_{opr}		-40~+125	°C
Storage temperature	T_{stg}		-65~+150	°C

Recommended Operating Conditions

The Recommended Operating Conditions table defines the conditions for actual device operation. Recommended operating conditions are specified to ensure optimal performance to the datasheet specifications.

Symbol	Parameter	Min.	Typ.	Max.	Unit	
	Power supply voltage	V_{CC}	3.7	12	28	V

Electrical Characteristics

Unless otherwise specified, $T_a=25^{\circ}\text{C}$, $V_{CC}=12\text{V}$

Parameter	Symbol	Condition	Ratings			Unit
			Min.	Typ.	Max.	
Power supply current	I_{CC}	Working		8	15	mA
VDD5 LDO						
Regulator voltage	VDD5		4.75	5	5.25	V

Regulator output current	Iv5out	VDD5=5V			20	mA
10V Regulator Block						
Regulator voltage	Vreg10		9.5	10.0	10.5	V
Regulator output current	Iv10out	Vreg10=10V			20	mA
Analog I/O Section*Note1						
Analog Input range			0		5.3	V
Digital Input Section*Note2						
High-level input voltage	Vdinh		2.5		5.3	V
Low-level input voltage	Vdinl		0		2	V
Internal pull up resistor	Rdio		150k	200k	250k	ohm
HP(High Side PMOS Driver) *Note3						
Output high voltage	HVoh	Sink current = 20mA	11.2	11.5	12	V
Output low voltage	HVol	Source current = 20mA		3	5	V
Output High Short Current	Io+	Out=0, PW<10 μs	150	200		mA
Output Low Short Current	Io-	Out=VCC, PW<10 μs	80	100		mA
LN(Low Side NMOS Driver) *Note4						
Output high voltage	LVoh	Sink current = 20mA	8.5	10	11	V
Output low voltage	LVol	Source current = 20mA	-	0	0.3	V
Output High Short Current	Io+	Out=0, PW<10 μs	100	125		mA
Output Low Short Current	Io-	Out=10V, PW<10 μs	250	300		mA
FG Output Pin						
FG output pin low-level voltage	VFG	When Io=5mA	-	0.1	0.2	V
VTH Comparative Level						
VTH comparative level Voltage	V _{th}			2.5		V
Thermal Protection Circuit						
Thermal protection circuit operating temperature	TSD	Design target		165		°C
Temperature hysteresis width	ΔTSD	Design target		15		°C
Low-Voltage Detection						
Low voltage detection voltage	UVLO			3.0		V
Operational Amplifier						
Input voltage range			0		VDD5	V
Output voltage range			0		VDD5	V
ADC						
Input range			0		VDD5	V
Parameter	Symbol	Condition	Ratings			Unit
			Min.	Typ.	Max.	
INL	INL			0.1	0.125	LSB
DNL	DNL			0.2	0.5	LSB

1. Note1: RPI、RSF、SREF、ILIMIT、ITRIP、VTH、LA、INN、INP、EMF_U、EMF_V、EMF_W.

2. Note2: PWM、F/R、START、BRAKE、FAULT.

3. Note3: UH、VH、WH

4. Note3: UL、VL、WL

Functional Description and Notes

Please read the following notes before designing driver circuits with FT3106.

1. Motor Start.

During startup, no induced voltage is generated due to the stationary motor, and the rotor position cannot be detected in sensorless mode. Therefore, FT3106 rotor first aligns the rotor to a known position in DC excitation mode for an appropriate period of time, but rotor also can be unaligned at first according to the actual conditions by ALIGN pin. This is followed with a forced commutation mode, where the duty cycle of PWM and the frequency of commutation are determined by the RPI pin and the RSF pin separately. The duty cycle of PWM increases proportionally with the increasing RPI voltage, while the period of commutation increases proportionally with the RSF voltage. The RSF and RPI voltage settings may vary depending on the motor type and load, so that they should be experimentally adjusted carefully. Starting of motor may fail if unsuitable values of RSF and RPI are used. The voltage range of RPI and RSF is 0V to VDD5+0.3V. When the motor rotates, generating stable and detectable back-EMF, correct position can be detected and forced commutation will transit into sensorless commutation.

2. PWM Output

FT3106 can be programmed to drive the motor with the traditional BLDC (120°) mode. The voltage and current sequence diagram is shown in Figure 1.

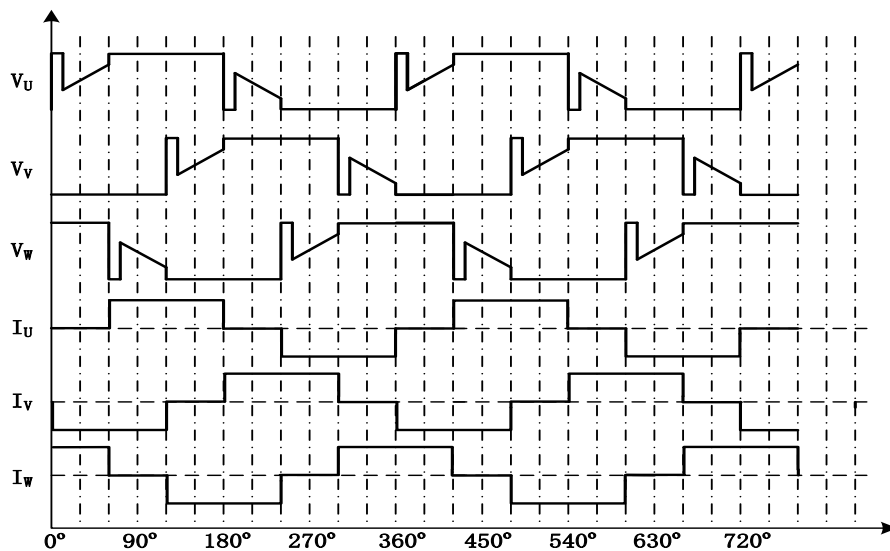

Figure 1 Voltage and Current Sequence diagram

3. Speed Control Methods

FT3106 has two methods to adjust the motor speed, using PWM pin by adjusting its duty cycle or using SREF pin by adjusting the voltage level. Please note that during speed adjustment with PWM, SREF must be disabled and pulled high. Conversely during speed adjustment with SREF, PWM must be disabled and pulled high.

When adjusting speed with PWM, the speed is varied by performing switching in accordance with the duty cycle that is provided to the PWM pin. When adjusting speed with SREF, speed is adjusted by an internally generated PWM with the duty cycle determined by the equation:

$$Duty_cycle = \frac{V_{SREF} - 0.75}{3}$$

When the SREF pin is connected to VDD5 and the motor speed will rise to full speed. When SREF pin is lower than 0.75V during operation, the motor will slow down and stop.

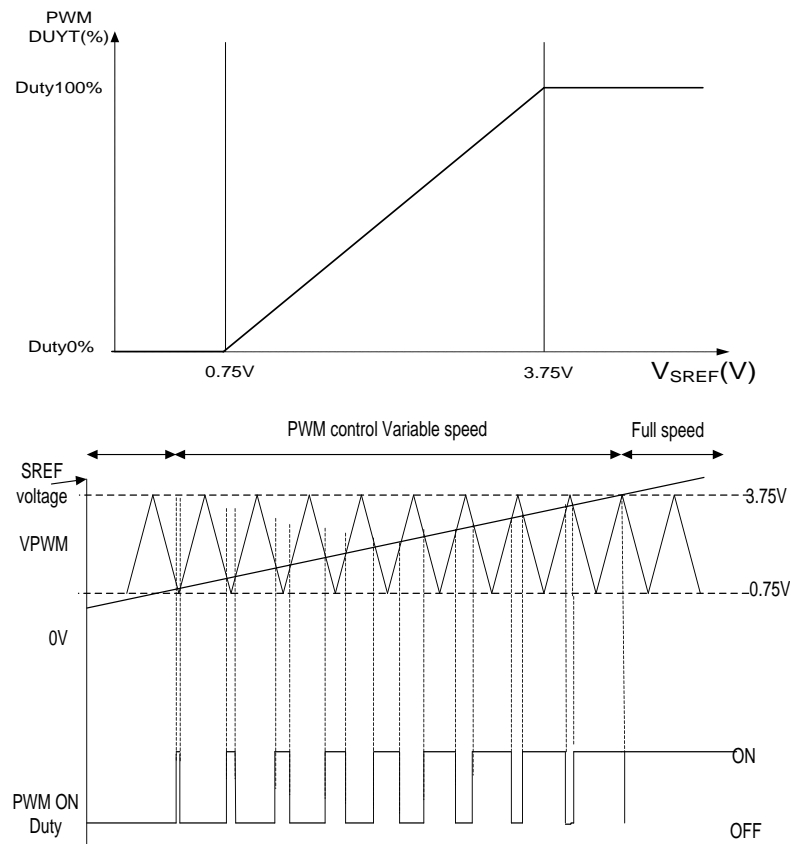

Figure 2 Rotation Speed Control Chart

4. Frequency Generator Function

The Frequency Generator output generates a rotation pulse to give information about the speed of motor. The default setting is 1 pulse per electrical degree (FG). The FG pin is an open drain output, connecting to a logical voltage level through an external pull-up resistor. This pin can be left open if unused.

5. EMF Feedback

EMF_U\ EMF_V\ EMF_W are motor back-EMF inputs and must be proportionately stepped down to less than VDD5 for protection of the IC.

6. Brake Function

FT3106 comes with brake function. Braking comes intelligently for protective purpose. When BRAKE pin is set to low, if the motor is rotating above the brake threshold speed, output MOSFETs are turned off to brake the motor. However, if the motor is rotating below the brake threshold speed, and the lower legs of the output MOSFETs are turned on to brake the motor. The reason for this distinction is to protect the MOSFETs from excessive braking currents due to large back-EMF. The default setting is 1000rpm for motor of four pole-pairs and 2000rpm for motor of two pole-pairs.

7. Built-in Independent Operational Amplifier

FT3106 comes with an independent operational amplifier. The INP pin is the positive input of the operational amplifier and the INN pin is the negative input of the operational amplifier. The OPO pin is the output of the operational amplifier.

8. Lead Angle Correction

The lead angle of generated motor driving signal related to the induced magnetic voltage can be shifted by an angle between 0 and 15 degrees. Lead angle control can be achieved by directly applying a voltage to the LA pin.

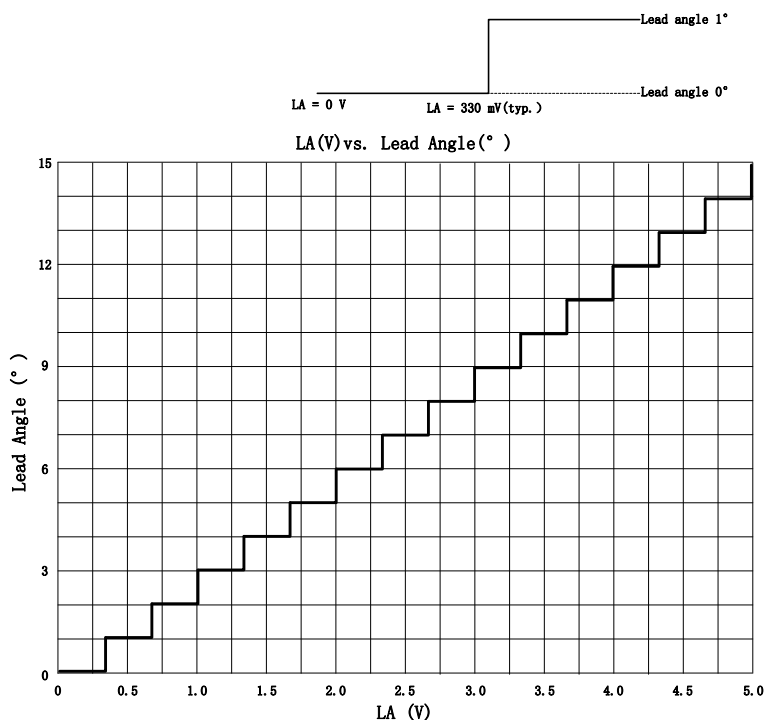

Figure 3 LA vs Lead Angle

<Typical Characteristics of the LA versus Lead Angle>

Step	LA (V)	Lead angle(°)	Step	LA(V)	Lead angle(°)	Step	LA (V)	Lead angle(°)
0	0.00	0.00	6	2.00	6.00	12	4.00	12.00
1	0.33	1.00	7	2.33	7.00	13	4.33	13.00
2	0.66	2.00	8	2.66	8.00	14	4.66	14.00
3	1.00	3.00	9	3.00	9.00	15	5.00	15.00
4	1.33	4.00	10	3.33	10.00			
5	1.66	5.00	11	3.66	11.00			

9. Lockup Protection and Automatic Restart

If motor rotation is abnormal, the internal detection circuit starts self-locking detection for a given time (Trun). If the motor keeps stalling under the Trun, the lock-up protection circuit disable the driver (by setting its outputs to high-impedance) in order to prevent the motor coil from burnout. After a “waiting time (Twait)”, the lock-up protection is released and normal operation resumes. Similarly if rotation is abnormal for another time period, Trun, lock-up protection is triggered. Twait and Trun timings are configurable with internal efuse and can be modified by user. The Twait is about 5seconds and Trun is about 2 seconds for FT3106.

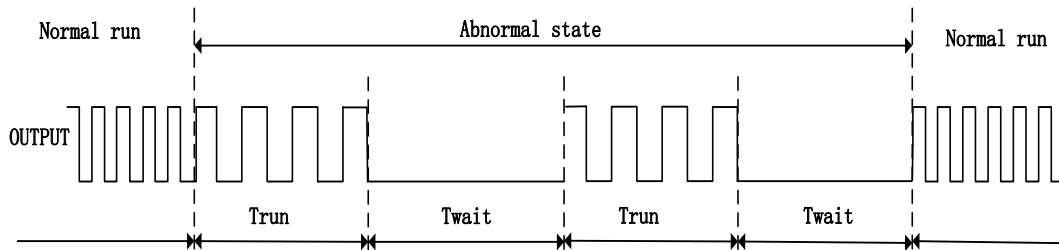

Figure4 Lockup Protection and Automatic Restart

10. Current Protections.

There are two methods of current protection: current limit protection and over current protection. The current limit circuit limits the output current peak value to a level determined by the equation:

$$I = V_{LIMIT} / R_{ITRIP}$$

When the voltage at the ITRIP input is higher than ILIMIT, the current limit protection is generated and the output PWM is turned off and evaluated every PWM cycle (cycle by cycle).

For over current detection, if a logic low voltage is seen at the FAULT pin, the over current protection is triggered, PWM is immediately turned off. After a “waiting time” (Twait), the over current protection is released and FT3106 restarts its operation with the startup sequence. FAULT pin can be left open if unused.

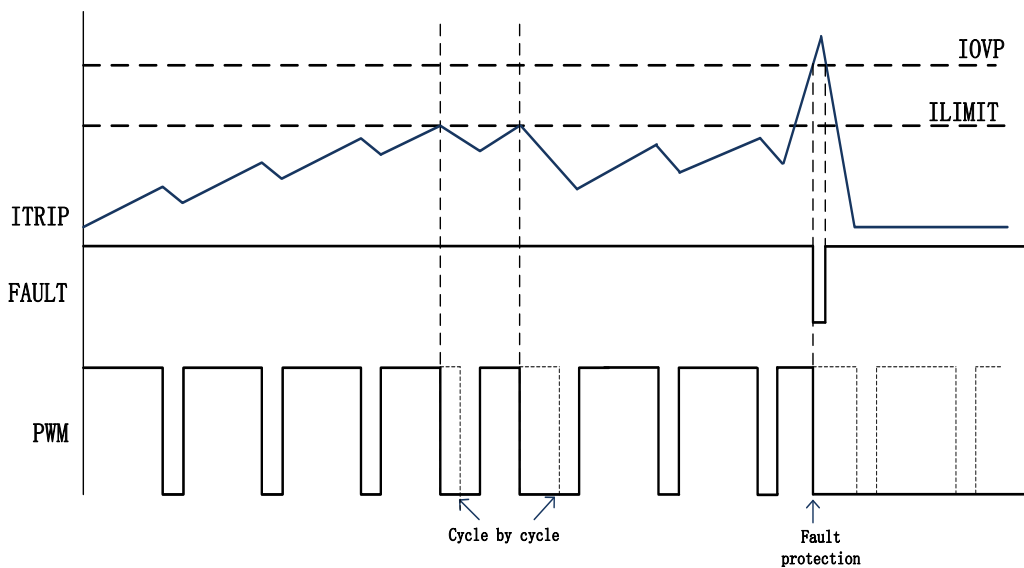
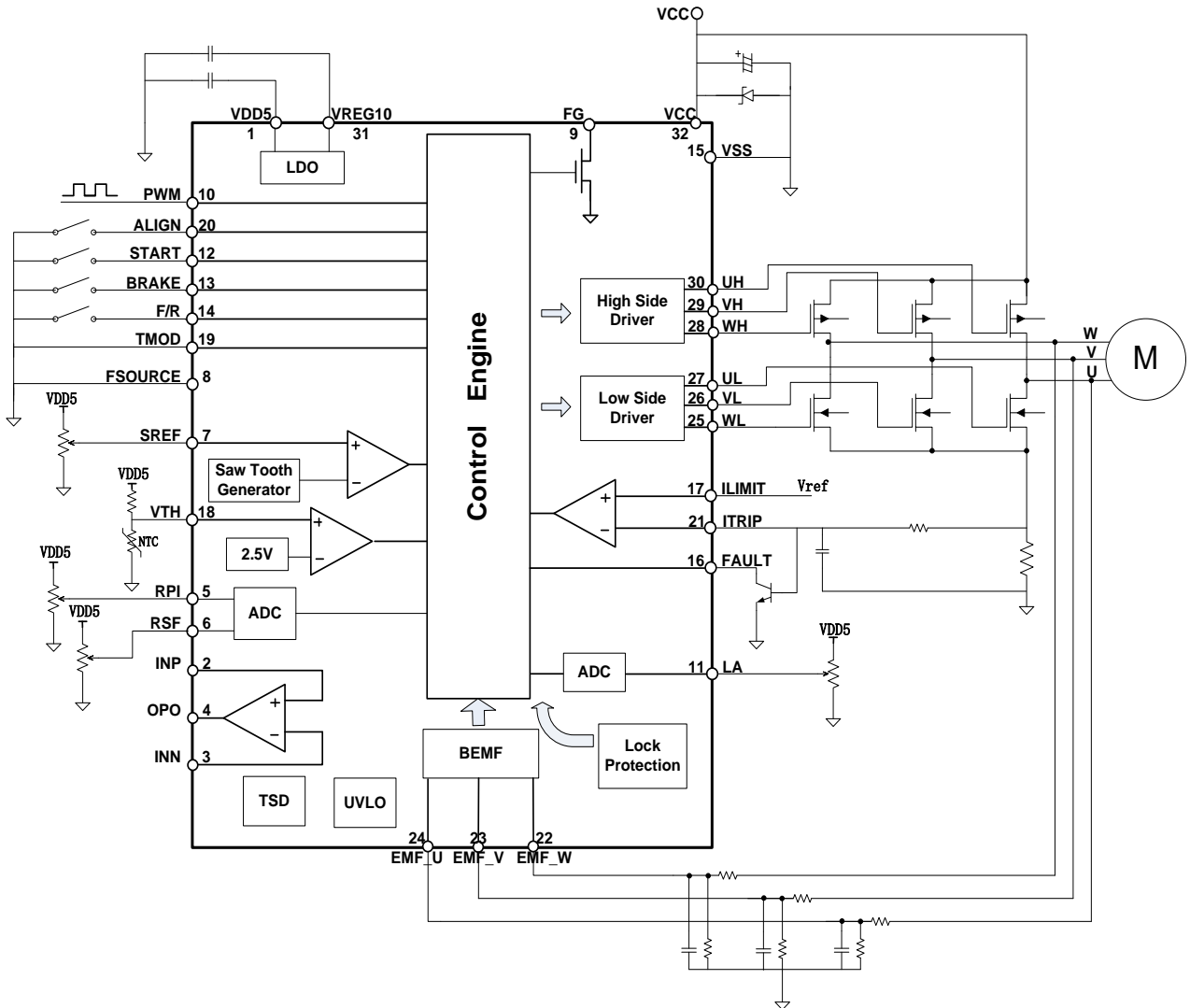

Figure 5 Operating Waveform of Current Protection

11. Thermal Protection.

For the thermal protection, the response of the FT3106 is determined by the voltage applied on VTH pin. In over temperature condition, if VTH is set to below 2.5V, FT3106 regards it as the abnormal state of the motor and the output transistors are turned off. When the VTH voltage exceeds 2.5V, FT3106 restarts its operation with the startup sequence.

Application Circuit Example



Package Information

QFN32 (5×5)

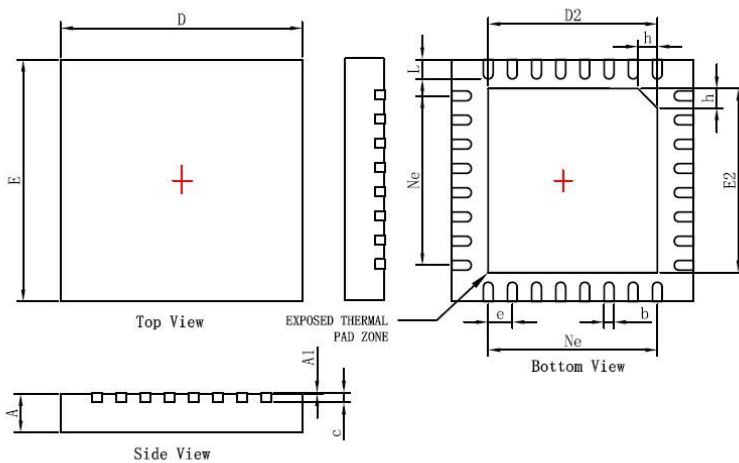

SYMBOL	MILLIMETER		
	MIN	NOM	MAX
A	0.70	0.75	0.80
A1	-	0.02	0.05
b	0.18	0.25	0.30
c	0.18	0.20	0.25
D	4.90	5.00	5.10
D2	3.40	3.50	3.60
e	0.50BSC		
Ne	3.50BSC		
E	4.90	5.00	5.10
E2	3.40	3.50	3.60
L	0.35	0.40	0.45
h	0.30	0.35	0.40
I/F载体尺寸	150×150		130×130

Copyright Notice

Copyright by Fortior Technology (Shenzhen) Co., Ltd. All Rights Reserved.

Fortior Technology (Shenzhen) Co., Ltd reserves the right to make changes in the products - including circuits, standard cells, and/or software - described or contained herein in order to improve design and/or performance. The information contained in this manual is provided for the general use by our customers. Our customers should ensure that they take appropriate action so that their use of our products does not infringe upon any patents. It is the policy of Fortior Technology (Shenzhen) Co., Ltd. to respect the valid patent rights of third parties and not to infringe upon or assist others to infringe upon such rights.

This manual is copyrighted by Fortior Technology (Shenzhen) Co., Ltd. You may not reproduce, transmit, transcribe, store in a retrieval system, or translate into any language, in any form or by any means, electronic, mechanical, magnetic, optical, chemical, manual, or otherwise, any part of this publication without the expressly written permission from Fortior Technology (Shenzhen) Co., Ltd.

Fortior Technology(Shenzhen) Co.,Ltd.

www.fortiortech.com