

## FT3168

---

### Self-Capacitance Touch Controller

***Preliminary***

Jun.18th, 2021

Version :0.6

Table of Contents

	<u>PAGE</u>
TABLE OF CONTENTS .....	3
INTRODUCTION.....	4
FEATURES .....	4
1. OVERVIEW.....	5
1.1. TYPICAL APPLICATIONS.....	5
2. FUNCTIONAL BLOCK DESCRIPTION.....	5
2.1. ARCHITECTURE OVERVIEW.....	6
2.1.1 AFE AND AFE CONTROLLER .....	6
2.1.2 MCU.....	6
2.1.3 OPERATION MODES .....	6
2.1.4 Watchdog Timer .....	6
2.1.5 PMU .....	6
2.2. OPERATING MODE .....	6
2.2.1. Active Mode .....	6
2.2.2. Monitor Mode .....	6
2.2.3. Sleep Mode .....	6
2.3. HOST INTERFACE.....	7
2.3.1. I <sup>2</sup> C Interface Timing.....	7
3. ELECTRICAL SPECIFICATIONS .....	8
3.1. ABSOLUTE MAXIMUM RATINGS.....	8
3.2. DC CHARACTERISTICS.....	9
3.3. AC CHARACTERISTICS.....	9
3.4. POWER ON AND RESET SEQUENCE.....	10
3.5. IO PORT CIRCUIT .....	13
4. PIN CONFIGURATION .....	14
5. PACKAGE INFORMATION .....	16
5.1. PACKAGE INFORMATION OF QFN3X3_24L PACKAGE .....	16
DISCLAIMER .....	17
6. REVISION HISTORY .....	18

## INTRODUCTION

The FT3168 is a single-chip capacitance touch panel controller IC with a built-in 16-bit enhanced Micro-controller unit (MCU). It adopts the self-capacitance technology, which supports multi-touch. In conjunction with a self-capacitance touch panel, The FT3168 implements the user-friendly input function and is widely used in various industry application and other touch application.

## FEATURES

- Self-Capacitive Sensing Techniques support single point touch and gesture or two-point touch.
- Absolute X and Y coordinates or gesture
- 1 point and gestures / 2 points supported
- Supports up to 16 channels of sensors
- Auto-Calibration: Insensitive to background capacitance and environmental variations
- High immunity to RF and Power interferences
- Excellent waterproof performance
- Support single film material TP and triangle pattern without additional shield
- Fast Report Rate: up to 100Hz
- Serial interfaces: I<sup>2</sup>C slave, up to 400Kbps
- Built-in 16-bit enhanced MCU
- Built-in 1.4V and 1.8V LDO Regulators
- Built-in 30MHz and 35KHz Oscillator
- Internal accuracy ADC and smooth filters
- Power Supply Mode
  - Power Supply: 2.8V-3.6V
  - independent IOVCC: 1.8V-3.6V
- High efficient power management with 3 Operating Modes
  - Active Mode
  - Monitor Mode
  - Sleep Mode
- Operating Temperature Range: -40°C to +85°C
- Package:
  - QFN3\*3\*0.55mm 0.35mm/pitch

### 1.OVERVIEW

#### 1.1. TYPICAL APPLICATIONS

FT3168 accommodates a wide range of applications with a set of buttons up to a 2D touch sensing device, their typical applications are listed below.

- Mobile phones, smart phones
- Smart watch
- Wrist Band
- GPS
- Game consoles
- POS (Point of Sales) devices
- Portable MP3 and MP4 media players
- Digital cameras
- MIDs

FT3168 support up to 1.4-inch Touch Panel; users may find out their target IC from the specs listed in the following table:

Model Name	Panel	Package			Touch Panel Size
	Channel	Type	Pin	Size	
FT3168	16	QFN3X3	25	3mm×3mm	≤2 inch

### 2.FUNCTIONAL BLOCK DESCRIPTION

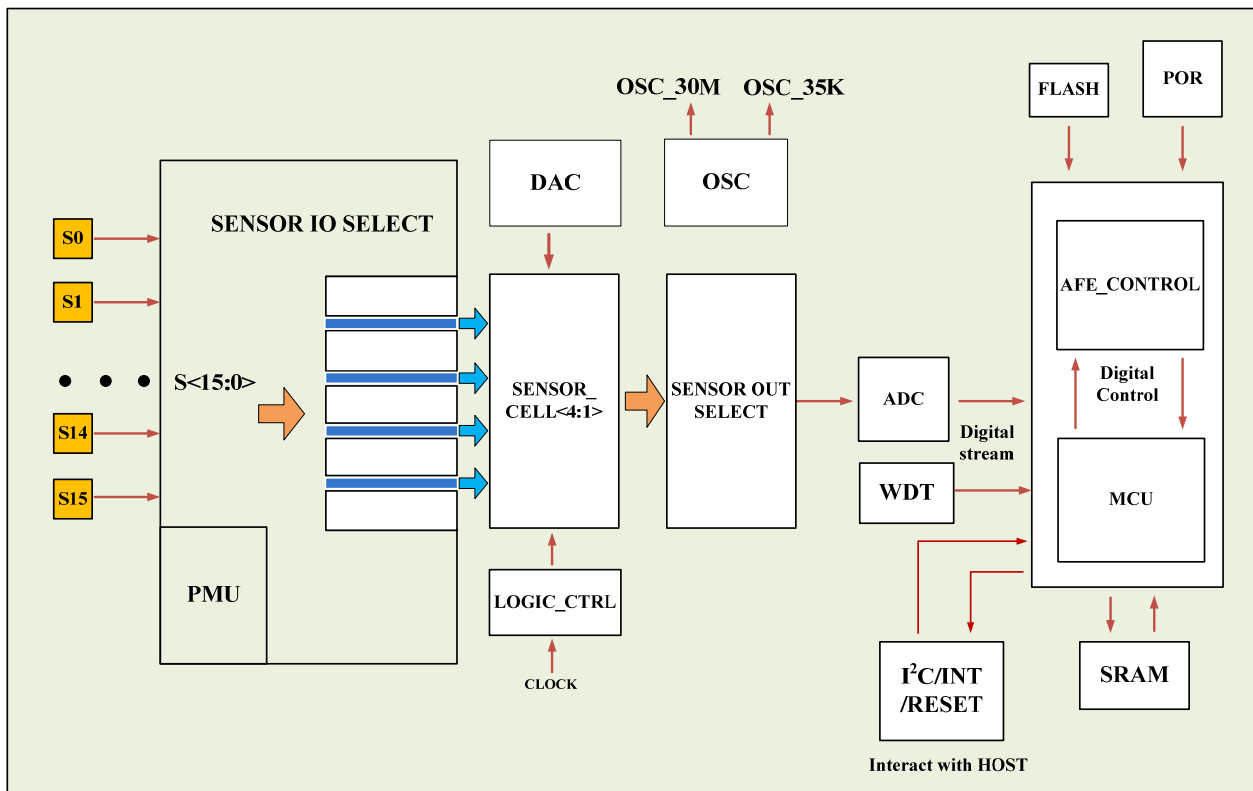

Figure 2-1FunctionBlock Diagram of FT3168

## 2.1. Architecture Overview

### 2.1.1 AFE and AFE Controller

The main function for the AFE and AFE controller is to interface with the touch panel. It scans the panel by sending AC signals to the panel and processes the received signals from the panel. So it supports both driver and Sensor functions. Key parameters to configure this circuit can be sent via serial interfaces.

### 2.1.2 MCU

For MCU, larger program and data memories are supported. Furthermore, a Flash Memory is implemented to store programs and some key parameters. Complex signal processing algorithms are implemented by MCU to detect the touches reliably and efficiently. Communication protocol software is also implemented on this MCU to exchange data and control information with the host processor.

### 2.1.3 Operation Modes

- SDA/SCL: I<sup>2</sup>C Interface for data exchange with host.
- INT: Interrupt signal to inform the host processor that touch data is ready for read.
- RESETB: External Hardware reset for FT3168; low is active.

### 2.1.4 Watchdog Timer

Watchdog timer is implemented to ensure the robustness of the chip.

### 2.1.5 PMU

PMU is power management unit, to generate voltage power / reference for internal circuit.

## 2.2. Operating Mode

FT3168 operates in the following three modes:

### 2.2.1. Active Mode

In this mode, FT3168 actively scans the panel. The default scan rate is 60 frames per second. The host processor can configure FT3168 to speed up or to slow down.

### 2.2.2. Monitor Mode

- In this mode, the FT3168 is scanning the touch sensor at a lower scan rate, which is user programmable. The purpose of this mode is to detect whether there is a touch on the screen. If a touch is detected, the FT3168 will switch to active mode immediately. In the case of mobile phone applications, the display is typically "on" in this mode.
- In Monitor mode, the FT3168 does not perform full touch tracking. It only looks for a valid touch. No coordinates or sensor image are calculated or reported.

### 2.2.3. Sleep Mode

FT3168 is not scanning the touch sensor. The analog circuits are turned off and the MCU stopped. The FT3168 will wake up and respond to "RESETB" or "Wakeup" signal from host processor. The display is typically off in this mode.

### 2.3. Host Interface

FT3168 communicates to the host through the I<sup>2</sup>C interface and follows the I<sup>2</sup>C protocol. I<sup>2</sup>C bus utilize the SCL and SDA, a two-wire synchronous communication interface and can operate at a maximum bit rate of 400kbps. FT3168 can be part of a single-slave or a multi-slave environment.

When FT3168 is in Monitor mode or Sleep mode, host will not be able to communicate with the touch IC via I<sup>2</sup>C after accessing any other slave device on the same bus. In order to maintain I<sup>2</sup>C communication during Monitor/Sleep mode between host and touch IC in them multi-slave environment, the FT3168 firmware will clear I<sup>2</sup>C state machine periodically. Wake up status via a touch event could also change FT3168 from Monitor/Sleep mode to Active mode and clear the I<sup>2</sup>C state machine, hence ensuring the touch FT3168's I<sup>2</sup>C function properly.

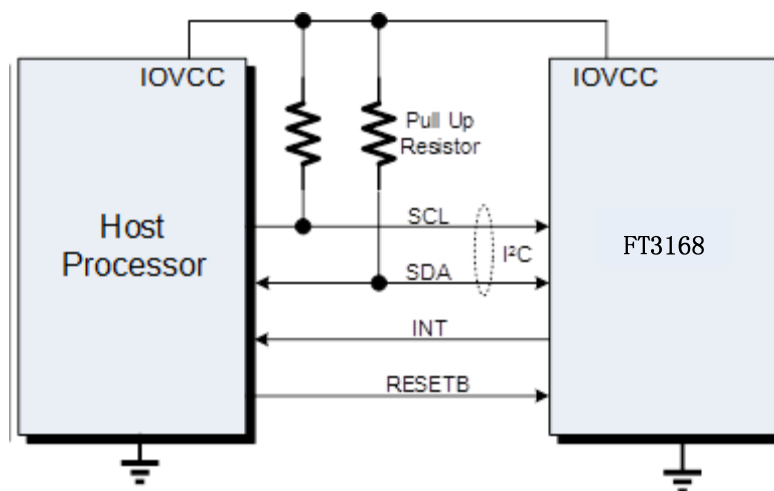

Figure 2-2 HOST Interface of FT3168

#### 2.3.1. I<sup>2</sup>C Interface Timing

The I<sup>2</sup>C is always configured in the Slave mode. The data transfer format is shown in Figure 2-3

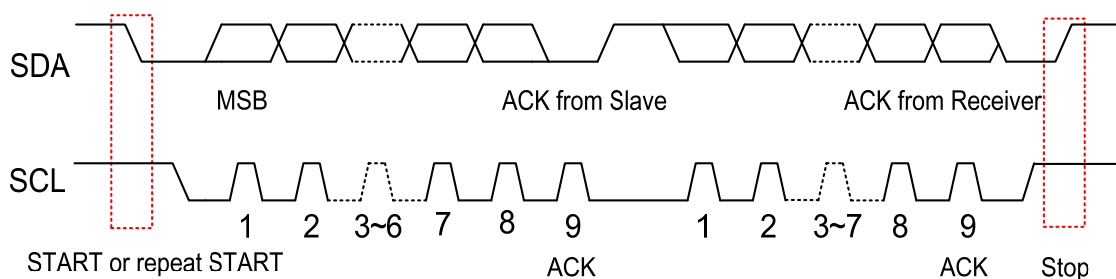

Figure 2-3 I<sup>2</sup>C Serial Data Transfer Format

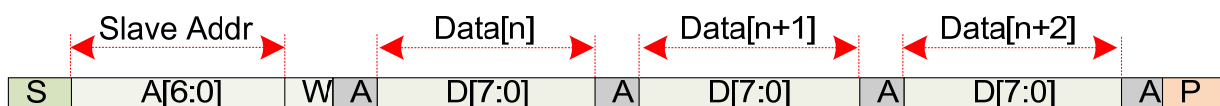

Figure 2-4 I<sup>2</sup>C Master Write, Slave Read

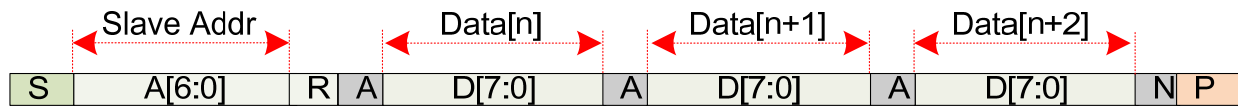

Figure 2-5 I<sup>2</sup>C Master Read, Slave Write

Table 2-1 lists the meanings of the mnemonics used in the above figures.

Table 2-1 Mnemonics Description

Mnemonics	Description
S	I <sup>2</sup> C Start or I <sup>2</sup> C Restart
A[6:0]	Slave address
R/W	READ/WRITE bit, '1' for read, '0' for write
A(N)	ACK(NACK)
P	STOP: the indication of the end of a packet (if this bit is missing, S will indicate the end of the current packet and the beginning of the next packet)

I<sup>2</sup>C Interface Timing Characteristics is shown in Table 2-2.

Table 2-2 I<sup>2</sup>C Timing Characteristics

Parameter	Standard Mode		Fast Mode		Unit
	Min	Max	Min	Max	
SCL frequency (fast mode support)	0	100	0	400	KHz
Clock low period	4.7	-	1.3	-	us
Clock high period	4.0	-	0.6	-	us
Bus free time between a STOP and START condition	4.7	-	1.3	-	us
Hold time (repeated) START condition	4.0	-	0.6	-	us
Data setup time	250	-	100	-	ns
Setup time for a repeated START condition	4.7	-	0.6	-	us
Setup Time for STOP condition	4.0	-	0.6	-	us

### 3.ELECTRICAL SPECIFICATIONS

#### 3.1. Absolute Maximum Ratings

Table 3-1 Absolute Maximum Ratings

Item	Symbol	Value	Unit	Note
Power Supply Voltage	AVDD - AVSS	-0.3 ~ +3.6	V	1, 2

I/O Communication Voltage	IOVCC (Internal generated when external IOVCC power is not existed)	1.75~1.85	V	1
	IOVCC (Internal LDO IOVCC is turned off when external IOVCC power is existed)	1.6~3.6	V	1
Operating Temperature	Topr	-40 ~ +85	°C	1
Storage Temperature	Tstg	-55 ~ +150	°C	1

**Notes**

1. If used beyond the absolute maximum ratings, FT3168 may be permanently damaged. It is strongly recommended that the device be used within the electrical characteristics in normal operations. If exposed to the condition not within the electrical characteristics, it may affect the reliability of the device.
2. Make sure AVDD (high) ≥ AVSS (low).

**3.2. DC Characteristics**

**Table 3-2 DC Characteristics (Ta=-40~105°C)**

Item	Symbol	Test Condition	Min.	Typ.	Max.	Unit	Note
Input high-level voltage	VIH		0.7 × IOVCC	-	IOVCC	V	
Input low -level voltage	VIL		-0.3	-	0.3 × IOVCC	V	
Output high -level voltage	VOH	IOH=−0.1mA	0.7 × IOVCC	-	-	V	
Output low -level voltage	VOL	IOH=0.1mA	-	-	0.3 × IOVCC	V	
I/O leakage current	ILI	Vin=0~AVDD	-1	-	1	μA	
Current consumption (Normal operation mode)	Iopr	AVDD=2.8V Ta=25°C MCLK=15MHz	-	1.5	-	mA	
Current consumption (Monitor mode)	Imon	AVDD=2.8V Ta=25°C MCLK=15MHz	-	30	-	μA	
Current consumption (Sleep mode)	Islp	AVDD=2.8V Ta=25°C	-	10	-	μA	
Power Supply voltage	AVDD		2.8	-	3.6	V	

**3.3. AC Characteristics**

**Table 3-3 AC Characteristics of Oscillators**

Item	Symbol	Test Condition	Min	Typ.	Max	Unit	Note
OSC clock	fosc1	AVDD= 2.8V; Ta=25°C	-1%	30	+1%	MHz	

**Table 3-4 AC Characteristics of sensor**



Item	Symbol	Test Condition	Min	Typ.	Max	Unit	Note
Sensor acceptable clock	ftx	AVDD= 2.8V; Ta=25°C	0	100	300	KHz	
Sensor output rise time	Ttxr	AVDD= 2.8V; Ta=25°C	-	100	-	nS	
Sensor output fall time	Ttxf	AVDD= 2.8V; Ta=25°C	-	80	-	nS	

**3.4. Power ON and Reset Sequence**

The GPIO such as INT and I2C are advised to be low before powering on. Reset should be pulled down to be low before powering on. INT signal will be sent to the host after initializing all parameters and then start to report points to the host. If power down, the voltage of supply must be below 0.3V and Trst is more than 5ms.

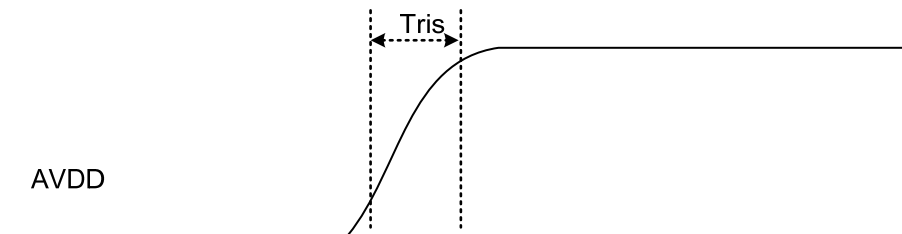

Figure 3-1 Power on time

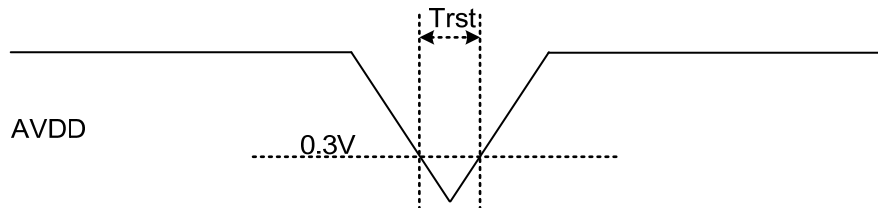

Figure 3-2 Power down requirement

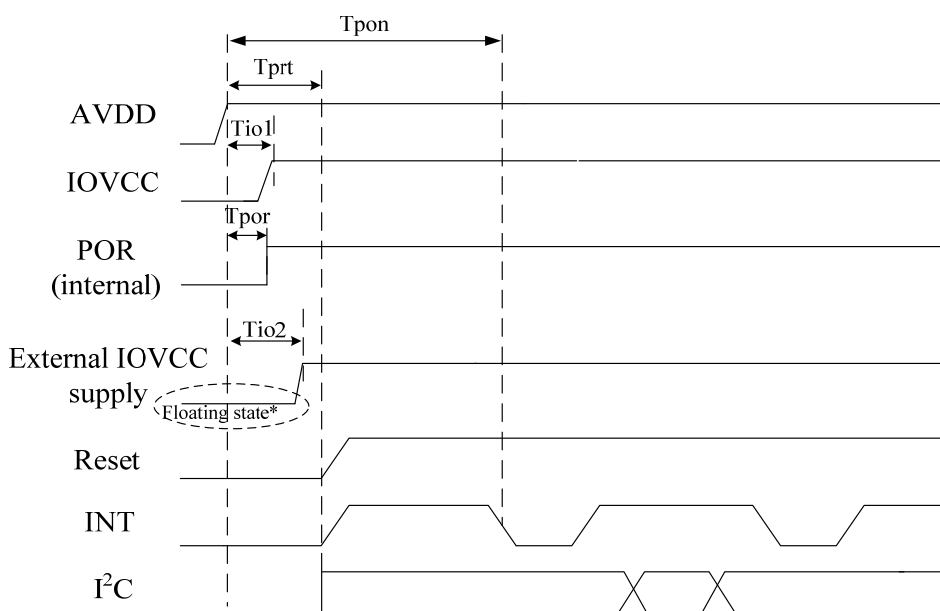

Figure 3-3 Power on Sequence (for external IOVCC supply exist)

Notes\*: external IOVCC supply should be in a floating state when it is not on to avoid unexpected leakage.

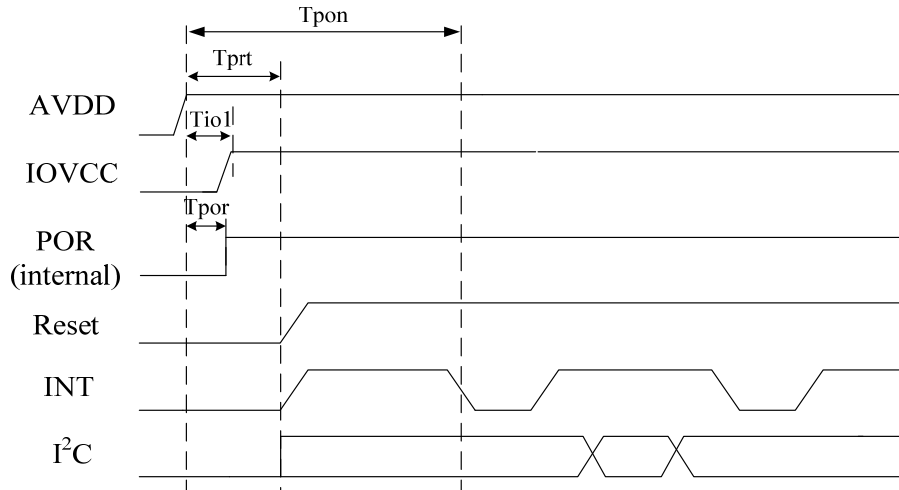

Figure 3-4 Power on Sequence (for external IOVCC supply not exist)

Reset time must be enough to guarantee reliable reset, the time of starting to report point after resetting approach to the time of starting to report point after powering on.

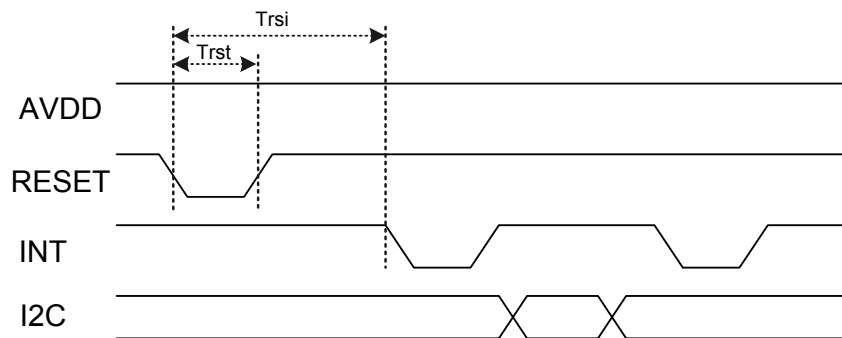

Figure 3-5 Reset Sequence

The following is the power down sequence.

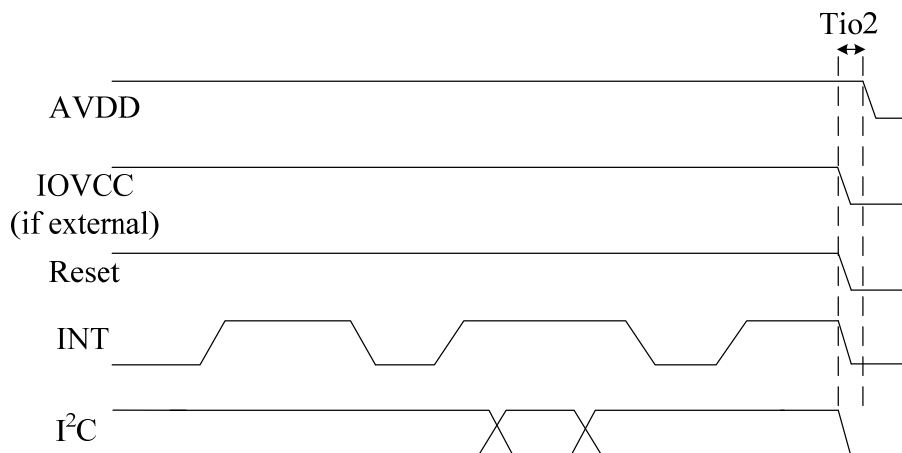

Figure 3-6 Power down Sequence (for external IOVCC)

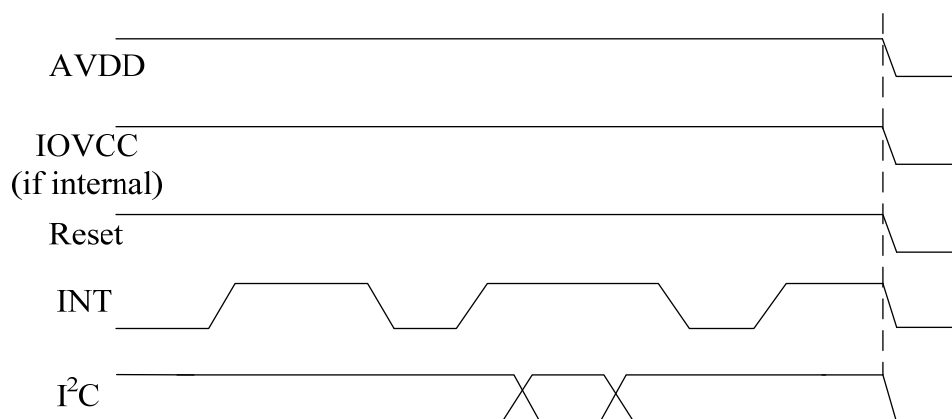

Figure 3-7 Power down Sequence (for internal IOVCC)

Table 3-5 Power on/Reset/Wake Sequence Parameters

Parameter	Description	Min	Max	Units
Tris	Rise time from 0.1VDD to 0.9VDD	-	3	ms
Tpor	Time of internal POR ready after AVDD power on	1	-	ms
Tio1	Time of IOVCC rising after AVDD power on	1	-	ms
Tio2	Time of external IOVCC supply after AVDD power on or time of external IOVCC supply before AVDD power down	1	-	ms
Tpon	Time of starting to report point after powering on	70	-	ms
Tprt*	Time of RESETB being low after power on	3	-	ms
Trsi	Time of starting to report point after resetting	70	-	ms
Trst*	Reset time	5	-	ms

Notes\*: reset time should not to be too long, because when reset is low, all the control logic would be fixed to be the default value, and the system state is fixed to be a default state.

### 3.5. IO PORT CIRCUIT

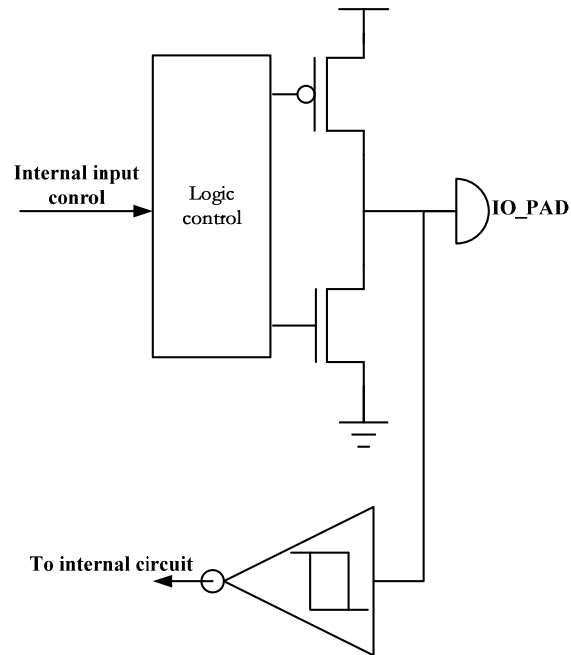

#### 4. PIN CONFIGURATION

**Table 4-1 Pin Definition of FT3168**

Name	Pin No.	Type	Description
S0	1	I/O	Capacitance sensor
S1	2	I/O	Capacitance sensor
S2	3	I/O	Capacitance sensor
S3	4	I/O	Capacitance sensor
S4	5	I/O	Capacitance sensor
S5	6	I/O	Capacitance sensor
S6	7	I/O	Capacitance sensor
S7	8	I/O	Capacitance sensor
S8	9	I/O	Capacitance sensor
S9	10	I/O	Capacitance sensor
S10	11	I/O	Capacitance sensor
S11	12	I/O	Capacitance sensor
S12	13	I/O	Capacitance sensor
S13	14	I/O	Capacitance sensor
S14	15	I/O	Capacitance sensor
S15	16	I/O	Capacitance sensor
VREF	17	PWR	Generated internal reference voltage. A 1 $\mu$ F ceramic capacitor to ground is required.
AVDD	18	PWR	Analog power supply, A 1 $\mu$ F ceramic capacitor to ground is required
IOVCC	19	PWR	I/O power supply
SCL	20	I/O	I2C clock input
SDA	21	I/O	I2C data input and output
INT	22	I/O	External interrupt to the host
RSTN	23	I	External Reset, Low is active
DVDD	24	PWR	Digital power supply. A 1 $\mu$ F ceramic capacitor to ground is required.
GND	25	PWR	Power ground. The pin that needs to be connected to the ground is exposed die attach pad.

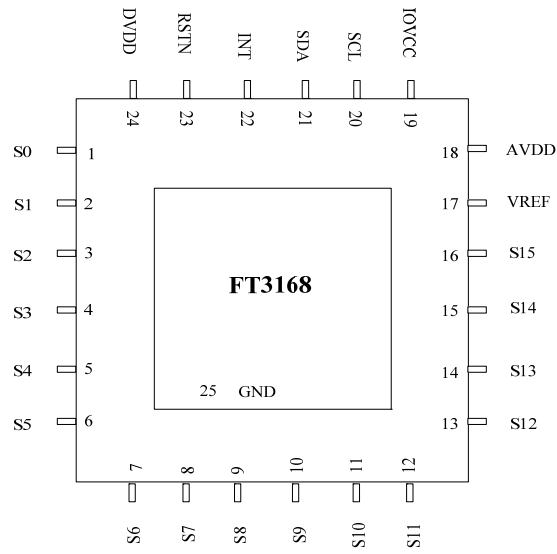

**Figure 4-1 FT3168 Package Diagram**

### 5. PACKAGE INFORMATION

#### 5.1. Package Information of QFN3X3\_24L Package

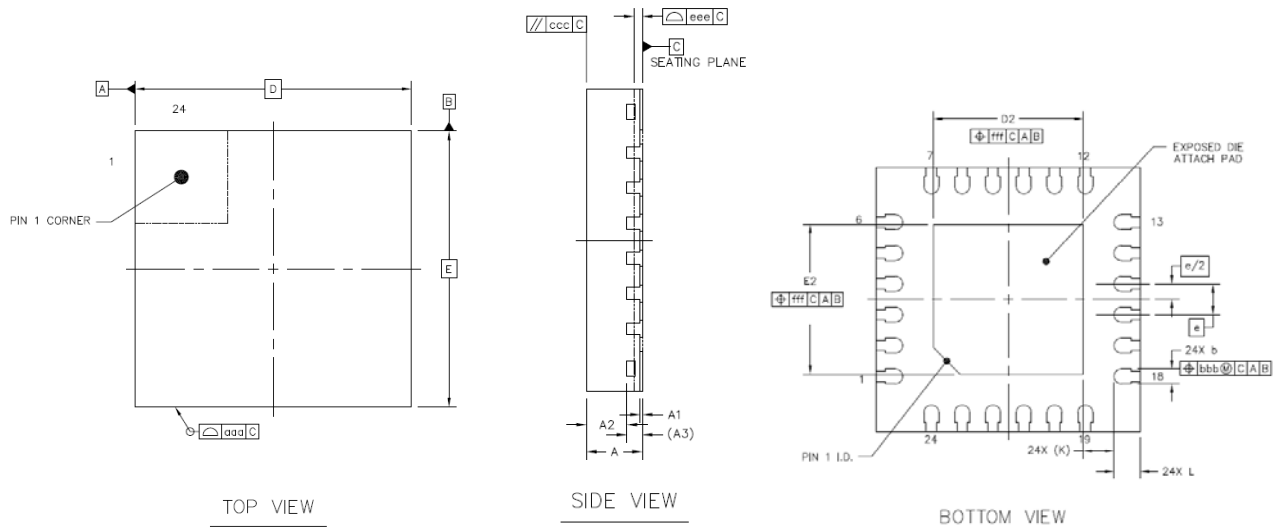

		SYMBOL	MIN	NOM	MAX
TOTAL THICKNESS		A	0.5	0.55	0.6
STAND OFF		A1	0	0.02	0.05
MOLD THICKNESS		A2	---	0.4	---
L/F THICKNESS		A3	0.152 REF		
LEAD WIDTH		b	0.12	0.17	0.22
BODY SIZE	X	D	3 BSC		
	Y	E	3 BSC		
LEAD PITCH		e	0.35 BSC		
EP SIZE	X	D2	1.6	1.7	1.8
	Y	E2	1.6	1.7	1.8
LEAD LENGTH		L	0.2	0.3	0.4
LEAD TIP TO EXPOSED PAD EDGE		K	0.35 REF		
PACKAGE EDGE TOLERANCE		aaa	0.1		
MOLD FLATNESS		ccc	0.1		
COPLANARITY		eee	0.08		
LEAD OFFSET		bbb	0.07		
EXPOSED PAD OFFSET		fff	0.1		

**DISCLAIMER**

The information appearing in this publication is believed to be accurate.

Integrated circuits sold by FocalTech Systems are covered by the warranty and patent indemnification provisions stipulated in the terms of sale only. FocalTech Systems makes no warranty, express, statutory implied or by description regarding the information in this publication or regarding the freedom of the described chip(s) from patent infringement. FURTHERMORE, FocalTech Systems MAKES NO WARRANTY OF MERCHANTABILITY OR FITNESS FOR ANY PURPOSE. FocalTech Systems reserves the right to halt production or alter the specifications and prices at any time without notice. Accordingly, the reader is cautioned to verify that the data sheets and other information in this publication are current before placing orders. Products described herein are intended for use in normal commercial applications. Applications involving unusual environmental or reliability requirements, e.g. military equipment or medical life support equipment, are specifically not recommended without additional processing by FocalTech Systems for such applications. Please note that application circuits illustrated in this document are for reference purposes only.



**6.REVISION HISTORY**

Date	Revision #	Description	Page	Auditor
Jan. 23th,2019	0.1	Original.	All	Jack.huang, 张金磊, 李瑞兴, 杜洪洋, 李华
Aug.20th,2019	0.2	Update sleep mode current consumption	11	李华
Otc.18th,2019	0.3	Modify Figure 3-2, Figure 3-4, Figure 3-5. Update Tpon and Trsi parameters minimum value. Add Figure 4-1 Package Diagram	12,13,15	李华、李瑞兴
Nov.22th,2019	0.4	Update OSC frequency And modify Table2-2	4,5,10 9	李瑞兴 李华
Jul.03th,2020	0.5	Modify IC support touch panel size Modify IIC interface description Update Power on sequence diagram Update Power on/Reset/Wake Sequence Parameters	5,7,11,12	李华, 张金磊, 黄 旻
Jun.18th,2021	0.6	Update power down sequence	12、13	李瑞兴