



FT6208

单通道直流马达驱动 规格书

芯天下技术股份有限公司
XTX Technology Inc.

Tel: (+86 755) 28229862
Fax: (+86 755) 28229847

Web Site: <http://www.xtxtech.com/>
Technical Contact: fae@xtxtech.com

* Information furnished is believed to be accurate and reliable. However, XTX Technology Inc. assumes no responsibility for the consequences of use of such information or for any infringement of patents or other rights of third parties which may result from its use. No license is granted by implication or otherwise under any patent rights of XTX Technology Inc. Specifications mentioned in this publication are subjected to change without notice. This publication supersedes and replaces all information previously supplied. XTX Technology Inc. products are not authorized for use as critical components in life support devices or systems without express written approval of XTX Technology Inc. The XTX logo is a registered trademark of XTX Technology Inc. All other names are the property of their respective own.

单通道 2.4V-7.2V 直流马达驱动芯片

产品概述

FT6208 是为消费类产品、玩具以及其它低压类或者电池供电的运动控制类应用提供的一个全集成的电机驱动器解决方案。此器件能够驱动一个直流有刷电机，由功率 PMOS 和 NMOS 组成，集成了电机正转/反转/停止/刹车四个功能。

FT6208 支持最高工作电压为 7.2V，持续电流 1.3A，峰值电流 2.5A。同时集成了过温保护和欠压闭锁等保护功能。

FT6208 具有 PWM (INA/INB) 输入接口，支持与行业标准器件兼容。

产品特征

- 工作电压范围：2.4V-7.2V
- 持续电流 1.3A，峰值 2.5A
- 待机电流：0.1uA typ.
- $R_{DS(ON)}$ 导通阻抗：0.58Ω
- 集成欠压保护
- 集成过热保护
- 封装：SOP8

典型应用

- 水气表阀门
- 电动牙刷
- IR-CUT
- 智能锁
- 电动玩具

典型应用电路



图 1. 典型应用电路

单通道 2.4V-7.2V 直流马达驱动芯片

封装外形图

SOP8

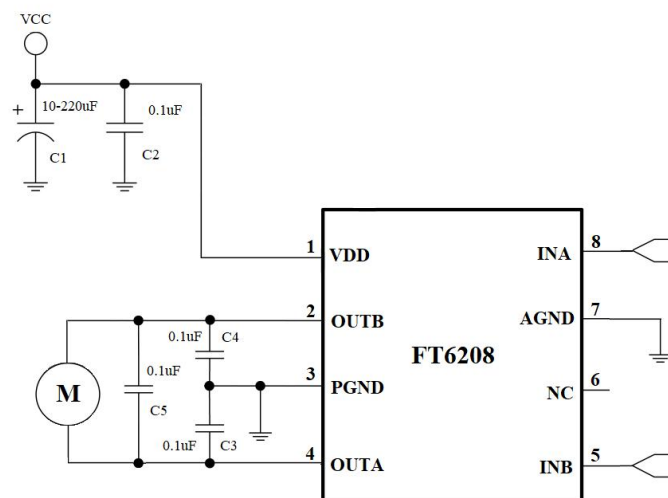
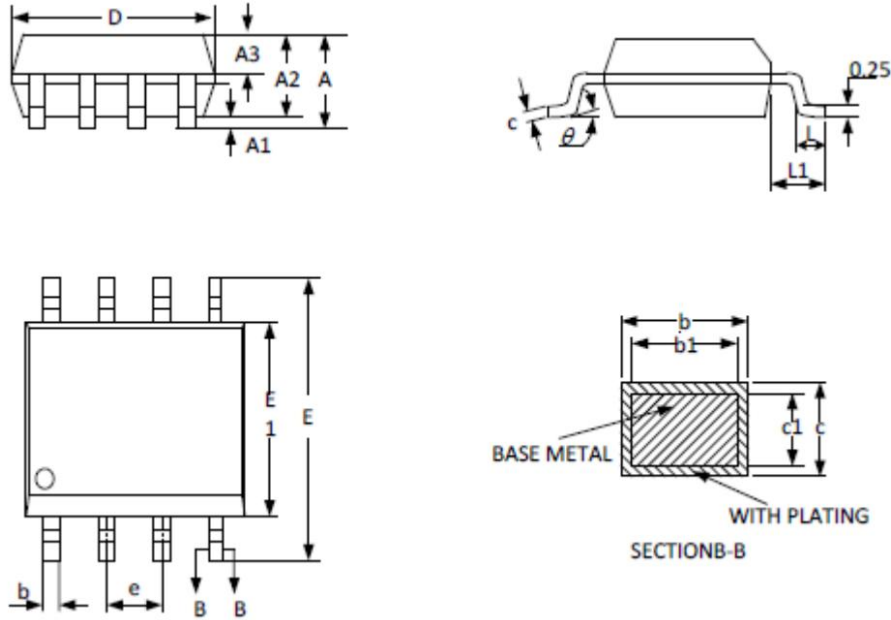

Symbol	Dimensions In Millimeters		
	Min	Nom	Max
A	-	-	1.77
A1	0.08	0.18	0.28
A2	1.20	1.40	1.60
A3	0.55	0.65	0.75
b	0.39	-	0.48
b1	0.38	0.41	0.43
c	0.21	-	0.26
c1	0.19	0.20	0.21
e	1.27BSC		
D	4.70	4.90	5.10
E	5.80	6.00	6.20
E1	3.70	3.90	4.10
L	0.50	0.65	0.80
L1	1.05BSC		
θ	0	-	8°