

600V N-Channel MOSFET

General Features

- Low ON Resistance
- Low Gate Charge (typical 54nC)
- Fast Switching
- 100% Avalanche Tested
- RoHS Compliant
- Halogen-free available

Applications

- High Efficiency SMPS
- Adaptor/Charger
- Active PFC
- LCD Panel Power

BV_{DSS}	$R_{DS(ON)}$ (Max.)	I_D
600V	0.75Ω	10.0A

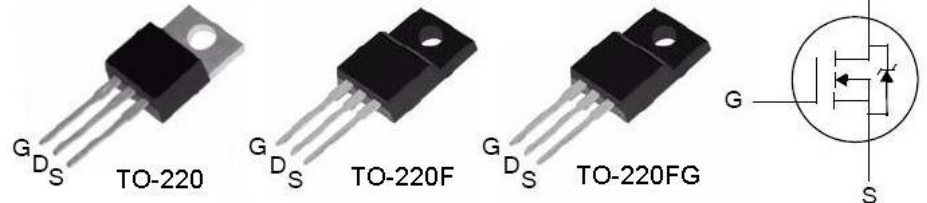

Ordering Information

Part Number	Package	Marking	Remark
FTP10N60	TO-220	FTP10N60	RoHS
FTP10N60G	TO-220	FTP10N60G	Halogen-free
FTA10N60	TO-220F	FTA10N60	RoHS
FTA10N60G	TO-220F	FTA10N60G	Halogen-free
FTA10N60Z	TO-220FG	FTA10N60Z	RoHS
FTA10N60GZ	TO-220FG	FTA10N60GZ	Halogen-free

Absolute Maximum Ratings

$T_C=25^\circ\text{C}$ unless otherwise specified

Symbol	Parameter	FTP10N60	FTA10N60	Unit
V_{DSS}	Drain-to-Source Voltage ^[1]	600		V
I_D	Continuous Drain Current	10.0	10.0*	A
$I_D@100^\circ\text{C}$	Continuous Drain Current	Figure 3		
I_{DM}	Pulsed Drain Current, $V_{GS}@10V^{[2]}$	Figure 6		
P_D	Power Dissipation	156	50	W
	Derating Factor above 25°C	1.25	0.4	W/°C
V_{GS}	Gate-to-Source Voltage	±30		V
E_{AS}	Single Pulse Avalanche Energy $L=12\text{mH}$, $I_D=10\text{A}$	600		mJ
dv/dt	Peak Diode Recovery dv/dt ^[3]	4.5		V/ns
T_L	Soldering Temperature Distance of 1.6mm from case for 10 seconds	300		°C
T_J and T_{STG}	Operating and Storage Temperature Range	-55 to 150		

*Drain Current limited by Maximum Junction Temperature.

Caution: Stresses greater than those listed in the "Absolute Maximum Ratings" may cause permanent damage to the device.

Thermal Characteristics

Symbol	Parameter	FTP10N60	FTA10N60	Unit
$R_{\theta JC}$	Thermal Resistance, Junction-to-Case	0.8	2.5	°C/W
$R_{\theta JA}$	Thermal Resistance, Junction-to-Ambient	60	60	

Electrical Characteristics

OFF Characteristics

 $T_C = 25^\circ\text{C}$ unless otherwise specified

Symbol	Parameter	Min.	Typ.	Max.	Unit	Test Conditions
BV_{DSS}	Drain-to-Source Breakdown Voltage	600	--	--	V	$V_{GS}=0V, I_D=250\mu A$
$\Delta BV_{DSS}/\Delta T_J$	Breakdown Voltage Temperature Coefficient	--	0.7	--	V/°C	Reference to 25°C, $I_D=250\mu A$
I_{DSS}	Drain-to-Source Leakage Current	--	--	20	μA	$V_{DS}=600V, V_{GS}=0V$
		--	--	100		$V_{DS}=480V, V_{GS}=0V,$ $T_C=125^\circ C$
I_{GSS}	Gate-to-Source Leakage Current	--	--	100	nA	$V_{GS}=+30V$
		--	--	-100		$V_{GS}=-30V$

ON Characteristics

 $T_C = 25^\circ\text{C}$ unless otherwise specified

Symbol	Parameter	Min.	Typ.	Max.	Unit	Test Conditions
$R_{DS(ON)}$	Static Drain-to-Source On-Resistance	--	0.65	0.75	Ω	$V_{GS}=10V, I_D=5.0A^{[4]}$
$V_{GS(TH)}$	Gate Threshold Voltage	2.0	--	4.0	V	$V_{DS} = V_{GS}, I_D=250\mu A$
gfs	Forward Transconductance	--	10.3	--	S	$V_{DS} = 40V, I_D=10A^{[4]}$

Dynamic Characteristics

Essentially independent of operating temperature

Symbol	Parameter	Min.	Typ.	Max.	Unit	Test Conditions
C_{ISS}	Input Capacitance	--	1809	--	pF	$V_{GS}=0V$ $V_{DS}=25V$ $f=1.0MHz$ Figure 14
C_{OSS}	Output Capacitance	--	142	--		
C_{RSS}	Reverse Transfer Capacitance	--	27.4	--		
Q_G	Total Gate Charge	--	54	--	nC	$V_{DD}=300V$ $I_D=10A$ Figure 15
Q_{GS}	Gate-to-Source Charge	--	7.7	--		
Q_{GD}	Gate-to-Drain (Miller) Charge	--	25.3	--		

Resistive Switching Characteristics

Essentially independent of operating temperature

Symbol	Parameter	Min.	Typ.	Max.	Unit	Test Conditions
$t_{d(ON)}$	Turn-on Delay Time	--	44	--	ns	$V_{DD}=300V$ $I_D=10A$ $V_{GS}=10V$ $R_G=25\Omega$
t_{rise}	Rise Time	--	116	--		
$t_{d(OFF)}$	Turn-off Delay Time	--	120	--		
t_{fall}	Fall Time	--	77	--		

Source-Drain Diode Characteristics
 $T_C=25^{\circ}\text{C}$ unless otherwise specified

Symbol	Parameter	Min	Typ.	Max.	Units	Test Conditions
I_{SD}	Continuous Source Current (Body Diode)	--	--	10	A	Integral P-N diode in MOSFET
I_{SM}	Maximum Pulsed Current (Body Diode)	--	--	40	A	
V_{SD}	Diode Forward Voltage	--	--	1.2	V	$I_S=10\text{A}$, $V_{GS}=0\text{V}$
t_{rr}	Reverse Recovery Time	--	337	--	ns	$V_{GS}=0\text{V}$ $I_F=10\text{A}$, $di/dt=100\text{A}/\mu\text{s}$
Q_{rr}	Reverse Recovery Charge	--	2.79	--	uC	

NOTE:

[1] $T_J=+25^{\circ}\text{C}$ to $+150^{\circ}\text{C}$

[2] Repetitive rating, pulse width limited by maximum junction temperature.

[3] $I_{SD}=10\text{A}$, $di/dt \leq 100\text{A}/\mu\text{s}$, $V_{DD} \leq BV_{DSS}$, $T_J=+150^{\circ}\text{C}$

[4] Pulse width $\leq 380\mu\text{s}$; duty cycle $\leq 2\%$.

Figure 1. Maximum Effective Thermal Impedance, Junction-to-Case

Figure 2. Maximum Power Dissipation vs. Case Temperature

Figure 3. Maximum Continuous Drain Current vs Case Temperature

Figure 4. Typical Output Characteristics

Figure 5. Typical Drain-to-Source ON Resistance vs. Gate Voltage and Drain Current

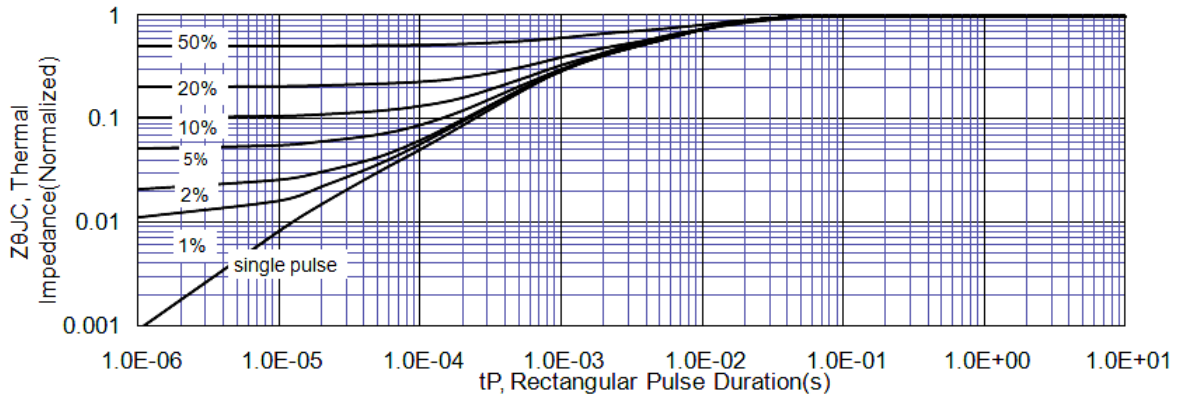
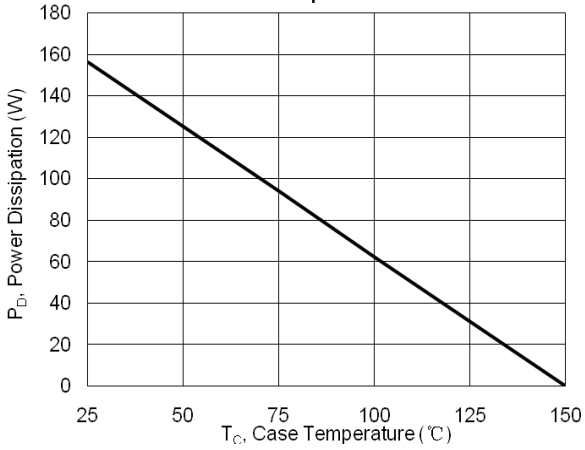
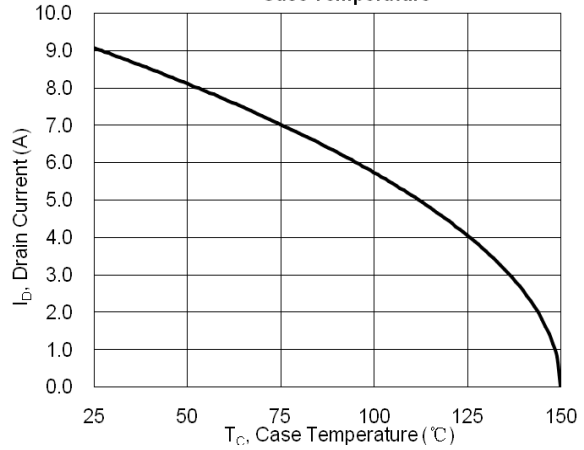
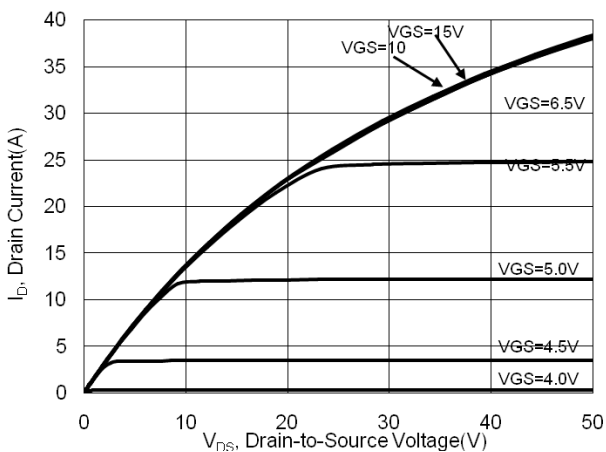
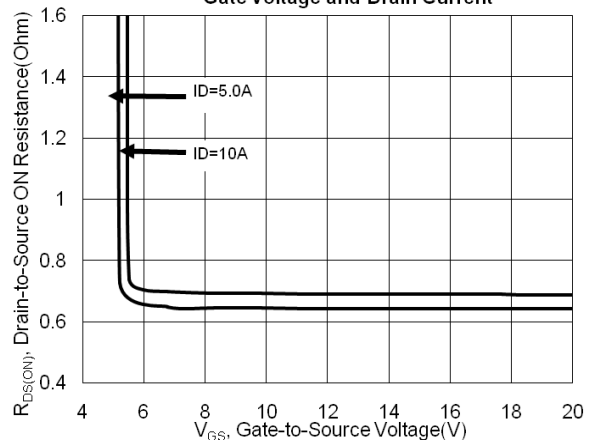
Figure 6. Maximum Peak Current Capability

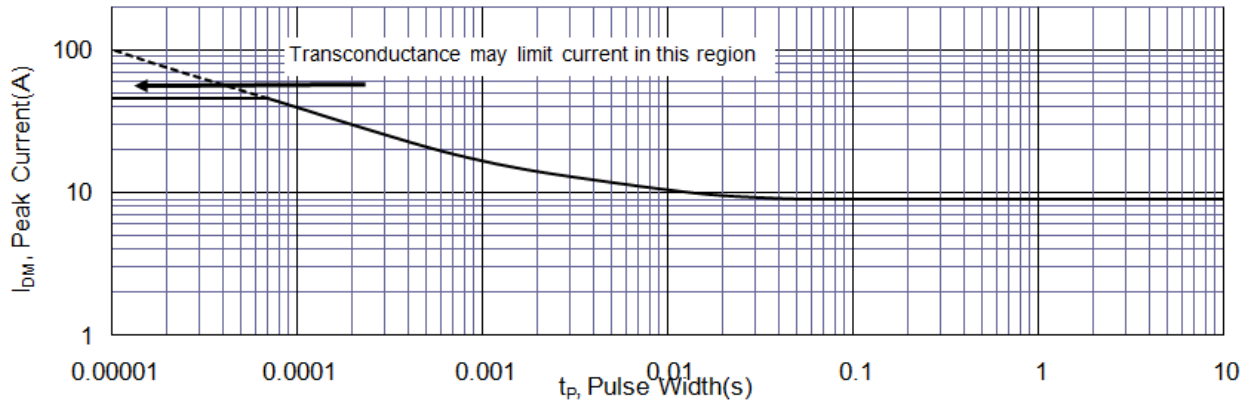

Figure 7. Typical Transfer Characteristics

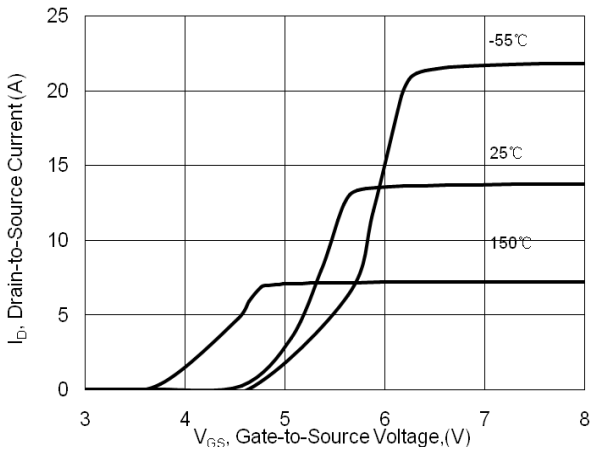

Figure 8. Unclamped Inductive Switching Capability

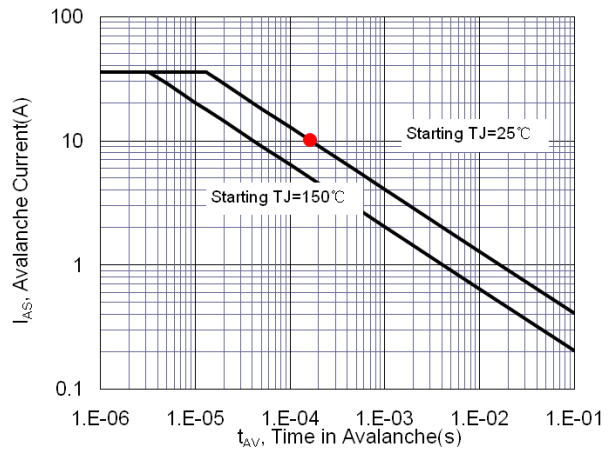

Figure 9. Typical Drain-to-Source ON Resistance

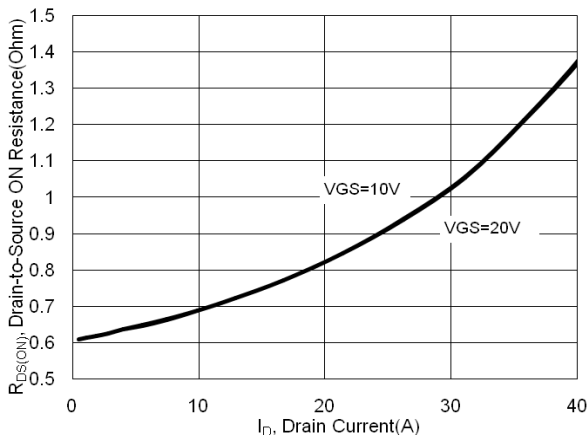

Figure 10. Typical Drain-to-Source On Resistance vs. Junction Temperature

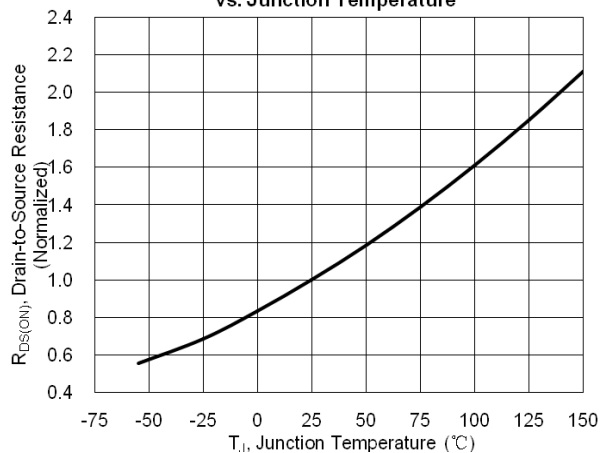

Figure 11. Typical Breakdown Voltage vs. Junction Temperature

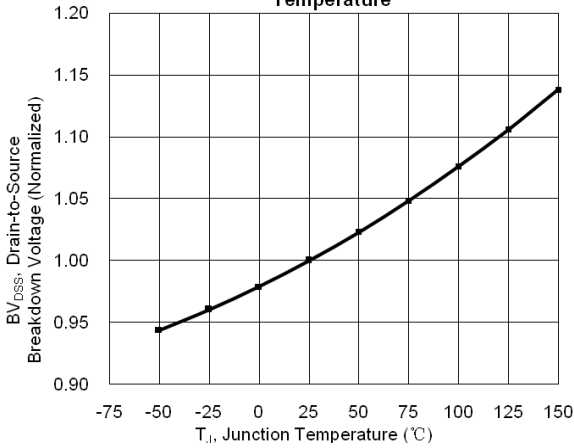

Figure 12. Typical Threshold Voltage vs. Junction Temperature

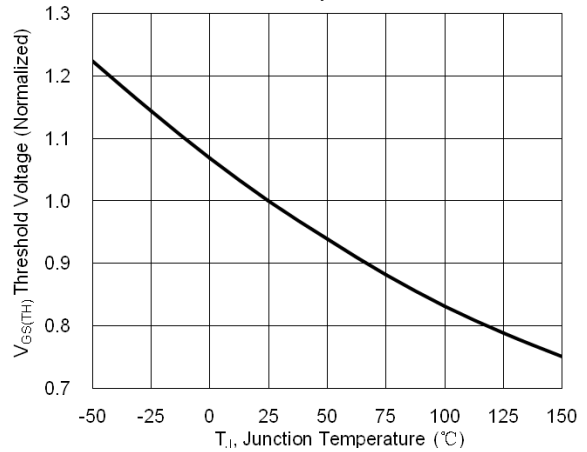

Figure 13. Maximum Forward Safe Operation Area

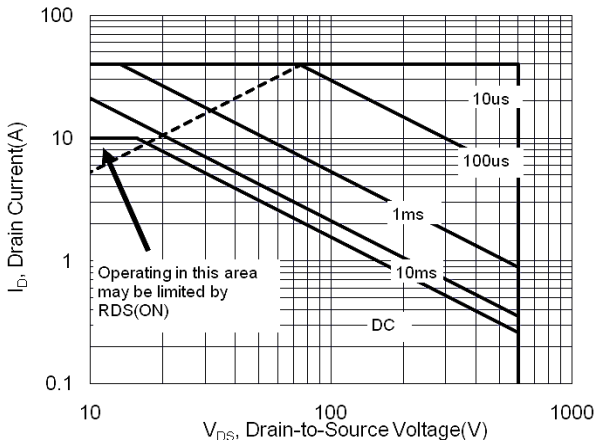

Figure 14. Typical Capacitance vs. Drain-to-Source Voltage

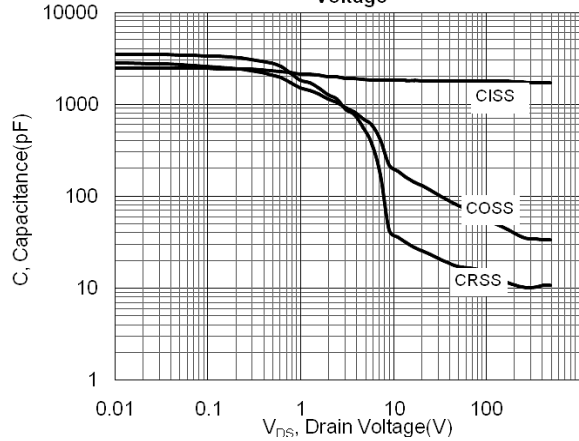

Figure 15. Typical Gate Charge vs. Gate-to-Source Voltage

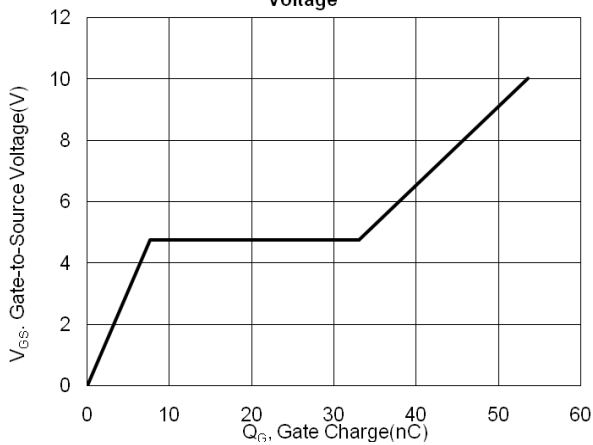
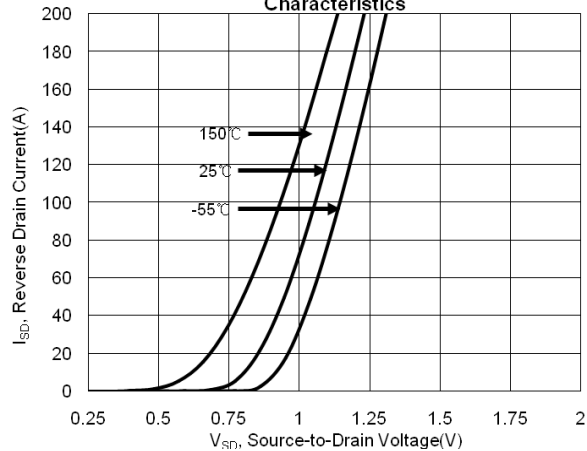
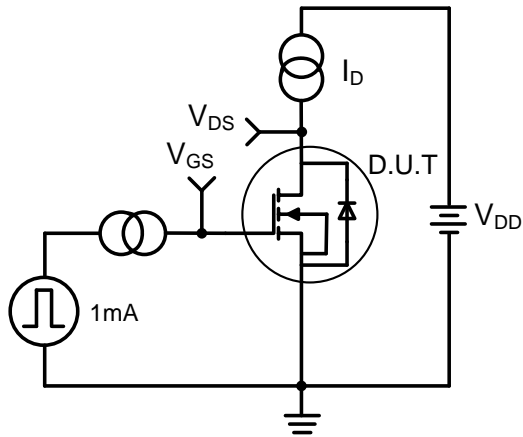
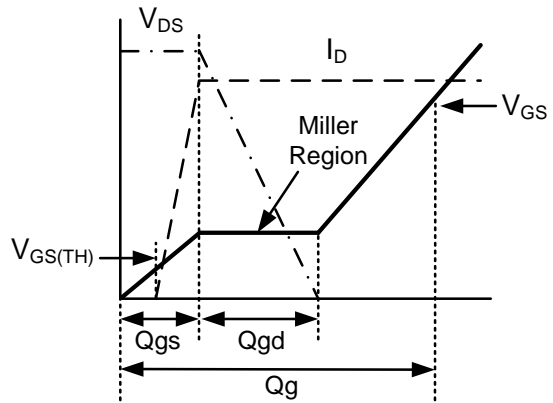
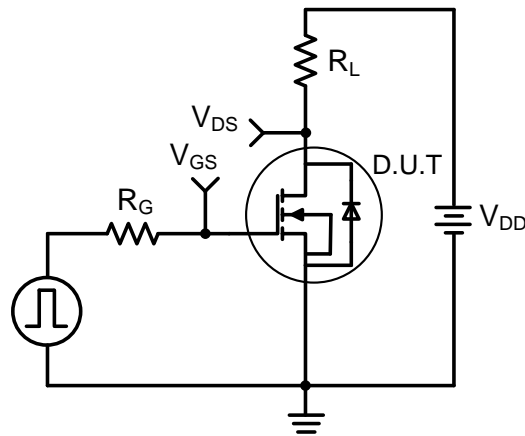
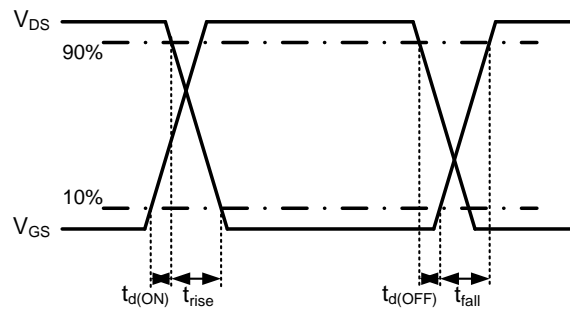

Figure 16. Typical Body Diode Transfer Characteristics



Test Circuit

Figure 17. Gate Charge Test Circuit

Figure 18. Gate Charge Waveform

Figure 19. Resistive Switching Test Circuit

Figure 20. Resistive Switching Waveforms

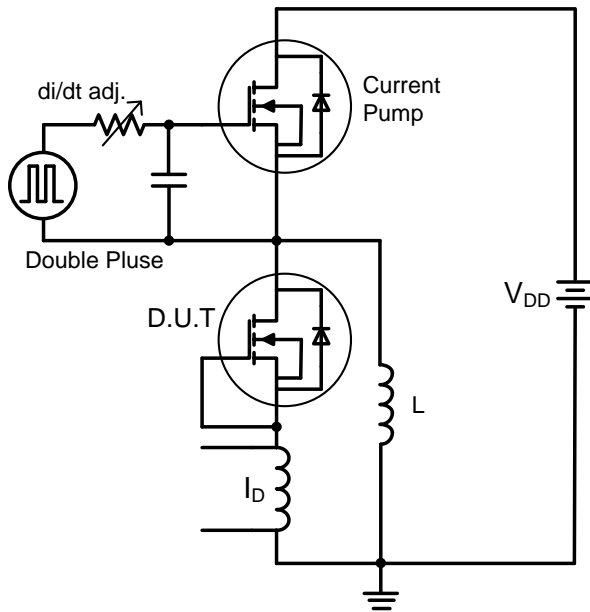

Figure 21. Diode Reverse Recovery Test Circuit

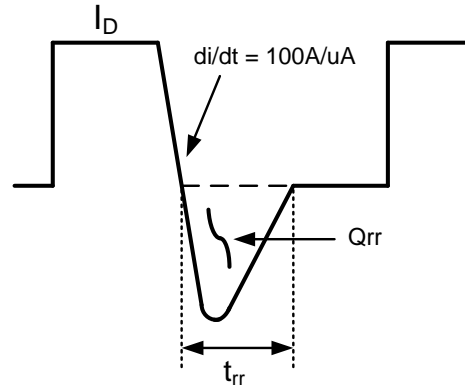

Figure 22. Diode Reverse Recovery Waveform

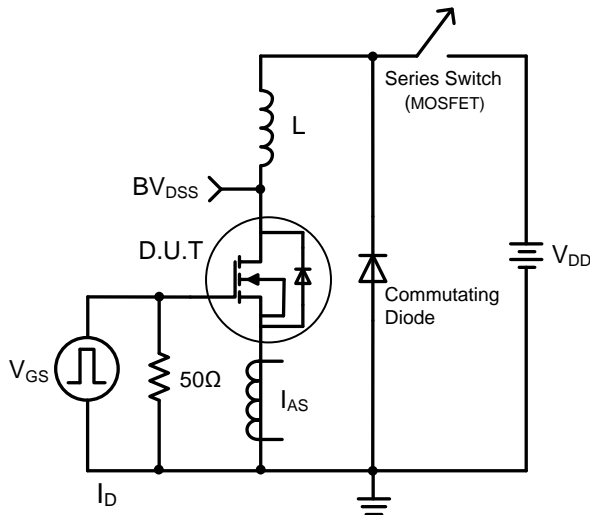

Figure 23. Unclamped Inductive Switching Test Circuit

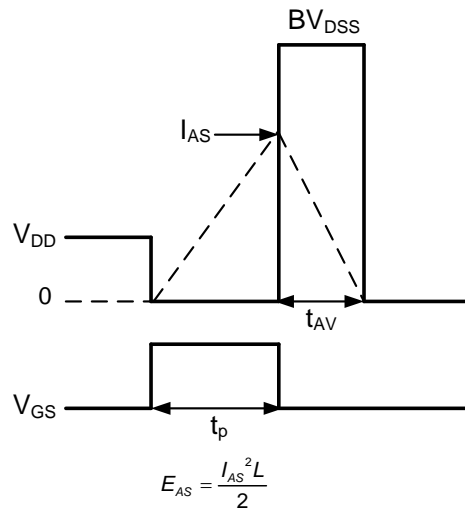

Figure 24. Unclamped Inductive Switching Waveforms



Published by
ARK Microelectronics Co., Ltd.
No.9, East Zijing Road, High-tec District, Chengdu, P. R. China
All Rights Reserved.

Disclaimers

ARK Microelectronics Co., Ltd. reserves the right to make change without notice in order to improve reliability, function or design and to discontinue any product or service without notice. Customers should obtain the latest relevant information before orders and should verify that such information is current and complete. All products are sold subject to ARK Microelectronics Co., Ltd's terms and conditions supplied at the time of order acknowledgement.

ARK Microelectronics Co., Ltd. warrants performance of its hardware products to the specifications at the time of sale, Testing, reliability and quality control are used to the extent ARK Microelectronics Co., Ltd deems necessary to support this warrantee. Except where agreed upon by contractual agreement, testing of all parameters of each product is not necessary performed.

ARK Microelectronics Co., Ltd. does not assume any liability arising from the use of any product or circuit designs described herein. Customers are responsible for their products and applications using ARK Microelectronics Co., Ltd's components. To minimize risk, customers must provide adequate design and operating safeguards.

ARK Microelectronics Co., Ltd. does not warrant or convey any license either expressed or implied under its patent rights, nor the rights of others. Reproduction of information in ARK Microelectronics Co., Ltd's data sheets or data books is permissible only if reproduction is without modification or alteration. Reproduction of this information with any alteration is an unfair and deceptive business practice. ARK Microelectronics Co., Ltd is not responsible or liable for such altered documentation.

Resale of ARK Microelectronics Co., Ltd's products with statements different from or beyond the parameters stated by ARK Microelectronics Co., Ltd. for the product or service voids all express or implied warranties for the associated ARK Microelectronics Co., Ltd's product or service and is unfair and deceptive business practice. ARK Microelectronics Co., Ltd is not responsible or liable for any such statements.

Life Support Policy:

ARK Microelectronics Co., Ltd's products are not authorized for use as critical components in life devices or systems without the expressed written approval of ARK Microelectronics Co., Ltd.

As used herein:

1. Life support devices or systems are devices or systems which:
 - a. are intended for surgical implant into the human body,
 - b. support or sustain life,
 - c. whose failure to perform when properly used in accordance with instructions for used provided in the labeling, can be reasonably expected to result in significant injury to the user.
 2. A critical component is any component is any component of a life support device or system whose failure to perform can be reasonably expected to cause the failure of the life support device or system, or to affect its safety or effectiveness.
-