

MITSUBISHI (OPTICAL DEVICES)  
**FU-68SDF-22**

**1.55  $\mu\text{m}$  DFB-LD MODULE WITH SINGLEMODE FIBER PIGTAIL  
 (BIAS CIRCUIT INTEGRATED, DIGITAL APPLICATION)**

**DESCRIPTION**

Module type FU-68SDF-22 is a 1.55 $\mu\text{m}$  DFB-LD module with single-mode optical fiber.

This module is suitable to a light source for use in 2.5Gb/s digital optical communication systems.

**FEATURES**

- Multi quantum wells (MQW) DFB Laser Diode module
- Input impedance is 25 $\Omega$
- Emission wavelength is in 1.55 $\mu\text{m}$  band
- High-speed response
- Built-in optical isolator
- Built-in thermal electric cooler
- Butterfly package
- With photodiode for optical output monitor

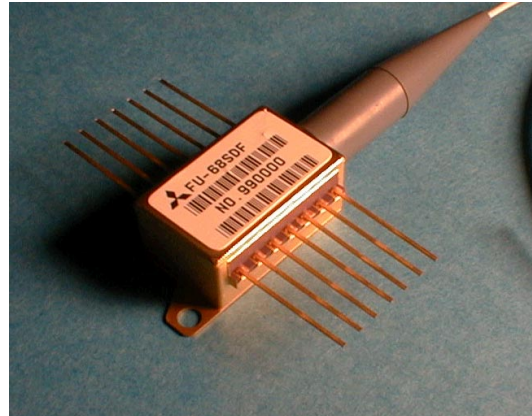

**APPLICATION**

High speed transmission systems (~2.5Gb/s)

**ABSOLUTE MAXIMUM RATINGS (T<sub>ld</sub>=25°C)**

Parameter		Symbol	Conditions	Rating	Unit
Laser diode	Optical output power from fiber end	P <sub>r</sub>	CW	10	mW
	Forward current	I <sub>f</sub>	CW	150	mA
	Reverse voltage	V <sub>ri</sub>	-	2	V
Photodiode for monitoring	Reverse voltage	V <sub>rd</sub>	-	20	V
	Forward current	I <sub>fd</sub>	-	2	mA
Cooler (Note)	Cooler voltage	V <sub>pe</sub>	-	2.4	V
	Cooler current	I <sub>pe</sub>	-	1.2	A
Operating case temperature		T <sub>c</sub>	-	-20~+65	°C
Storage temperature		T <sub>stg</sub>	-	-40~+70	°C

Note. Even if the thermo-electric cooler (TEC) is operated within the rated conditions, uncontrolled current loading or operation without heatsink may easily damage the module by exceeding the storage temperature range. Thermistor resistance should be properly monitored by the feedback circuit during TEC operation to avoid the catastrophic damage.

**MITSUBISHI (OPTICAL DEVICES)**  
**FU-68SDF-22**

**1.55  $\mu$ m DFB-LD MODULE WITH SINGLEMODE FIBER PIGTAIL**  
**(BIAS CIRCUIT INTEGRATED, DIGITAL APPLICATION)**

**ELECTRICAL/OPTICAL CHARACTERISTICS** (T<sub>ld</sub>=25°C, T<sub>c</sub>=25°C, unless otherwise noted)

Parameter	Symbol	Test Conditions	Limits			Unit
			Min.	Typ.	Max.	
Threshold current	I <sub>th</sub>	CW	-	12	40	mA
Operating current	I <sub>op</sub>	CW	-	55	90	mA
Operating Voltage	V <sub>op</sub>	CW, I <sub>f</sub> =I <sub>op</sub> (Note 1)	-	1.3	1.8	V
Input impedance	Z <sub>in</sub>	I <sub>f</sub> =I <sub>op</sub>	-	25	-	$\Omega$
Optical output power from fiber end	P <sub>f</sub>	CW, I <sub>f</sub> =I <sub>op</sub>	4	6	-	mW
Light-emission central wavelength	$\lambda_c$	CW, I <sub>f</sub> =I <sub>op</sub>	1530	1550	1570	nm
Spectral width (-20db full width)	$\Delta\lambda$	2.5Gb/s NRZ Mark ratio 50% I <sub>f_perk</sub> =I <sub>op</sub> Extinction ratio 8% (Note 2)	-	0.2	-	nm
Side mode suppression ratio	S <sub>r</sub>	CW, I <sub>f</sub> =I <sub>op</sub>	33	40	-	dB
Dispersion penalty	P <sub>p</sub>	2.48832Gbps NRZ PRBS 2 <sup>23</sup> -1 I <sub>f_peak</sub> =I <sub>op</sub> Extinction ratio=10% 100km (1700ps/nm) (Note 2)	-	-	2	dB
Cutoff frequency (-1,5dB optical)	f <sub>c</sub>	I <sub>f</sub> =I <sub>op</sub>	3.5	-	-	GHz
Rise and fall time (10~90%)	t <sub>r</sub> , t <sub>f</sub>	2.5Gb/s NRZ Mark ratio 50% I <sub>f_perk</sub> =I <sub>op</sub> Extinction ratio 8% (Note 2)	-	-	150	ps
Relative intensity noise	N <sub>r</sub>	CW, I <sub>f</sub> =I <sub>op</sub>	-	-155	-145	dB/Hz
Tracking error (Note 3)	E <sub>r</sub>	T <sub>c</sub> =-20~+65°C, APC, ATC	-	0.3	-	dB
Differential efficiency	$\eta$	-	0.09	0.15	0.35	mW/ mA
Monitor current	I <sub>mon</sub>	CW, I <sub>f</sub> =I <sub>op</sub> , V <sub>rd</sub> =5V	0.1	-	-	mA
Dark current (PD)	I <sub>d</sub>	V <sub>rd</sub> =5V	-	0.1	1	$\mu$ A
Capacitance (PD)	C <sub>t</sub>	V <sub>rd</sub> =5V, f=1MHz	-	10	-	pF

Note 1. I<sub>f</sub>: LD forward current

2. Optical return loss of the connectors should be greater than 40dB in order to get the specified performance.

3. E<sub>r</sub>=MAX|10×log(P<sub>f</sub>(T<sub>c</sub>)/P<sub>f</sub>(25°C))|

**1.55 $\mu$ m DFB-LD MODULE WITH SINGLEMODE FIBER PIGTAIL  
(BIAS CIRCUIT INTEGRATED, DIGITAL APPLICATION)**

**THERMAL CHARACTERISTICS (T<sub>ld</sub>=25°C, T<sub>c</sub>=-20~+65°C)**

Parameter	Symbol	Test Conditions	Limits			Unit
			Min.	Typ.	Max.	
Thermistor resistance	R <sub>th</sub>	T <sub>ld</sub> =25°C	9.5	10	10.5	K $\Omega$
B constant of thermistor resistance	B	-	-	3950	-	K
Cooling capacity	$\Delta T$	T <sub>c</sub> =65°C	40	-	-	°C
Cooler current	I <sub>pe</sub>	$\Delta T$ =40°C	-	0.6	1	A
Cooler Voltage	V <sub>pe</sub>	$\Delta T$ =40°C	-	1.2	2	V

**OPTICAL FIBER SPECIFICATION**

Parameter	Limits	Unit
Type	SM	-
Mode field dia.	9.5 $\pm$ 1	$\mu$ m
Cladding dia.	125 $\pm$ 2	$\mu$ m
Jacket dia.	0.9 typ.	mm

MITSUBISHI (OPTICAL DEVICES)  
**FU-68SDF-22**

1.55  $\mu\text{m}$  DFB-LD MODULE WITH SINGLEMODE FIBER PIGTAIL  
 (BIAS CIRCUIT INTEGRATED, DIGITAL APPLICATION)

OUTLINE DIAGRAM

(Unit : mm)

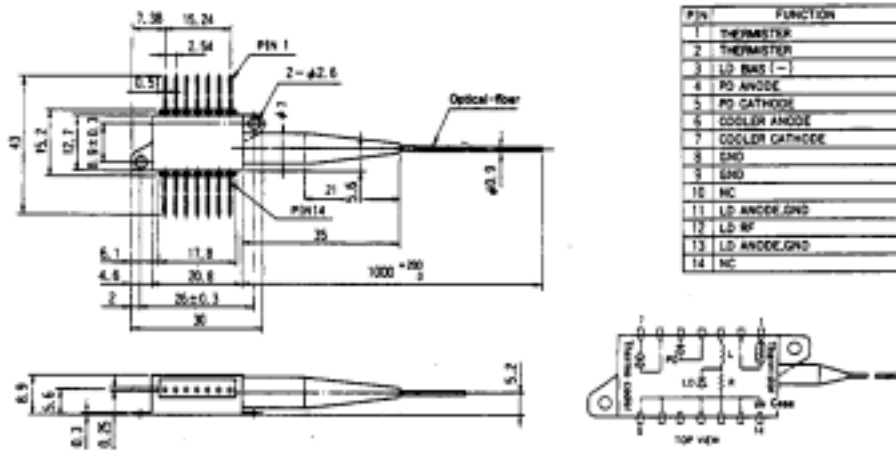

FU-68SDF-22