

Service  
Service  
**Service**



# Service Manual



**CONTENTS**

Technical specification ..... 1-2  
 Version variation ..... 1-2

Service measurement setup..... 1-3  
 Service aids ..... 1-4  
 Instructions on CD playability ..... 2-1..2-2

Block diagram ..... 3-1  
 Wiring diagram ..... 4-1  
 Disassembly diagram..... 5-1..5-2

Main board  
 Circuit diagram ..... 6-1  
 Layout diagram..... 6-2.. 6-3

AC board  
 Circuit diagram ..... 7-1  
 Layout diagram..... 7-2.. 7-3

Display board  
 Circuit diagram ..... 8-1  
 Layout diagram..... 8-2.. 8-3

AMP & Power Board  
 Circuit diagram ..... 9-1  
 Layout diagram ..... 9-2.. 9-3

Tuner board  
 Circuit diagram ..... 10-1  
 Layout diagram ..... 10-2

CD Board  
 Circuit diagram ..... 11-1  
 Layout diagram ..... 11-2.. 11-3

MCU Board  
 Circuit diagram ..... 12-1.. 12-2  
 Layout diagram ..... 12-3.. 12-4

Exploded view diagram ..... 13-1

© Copyright 2010 Philips Consumer Electronics B.V. Eindhoven, The Netherlands  
 All rights reserved. No part of this publication may be reproduced, stored in a retrieval  
 system or transmitted, in any form or by any means, electronic, mechanical, photocopying,  
 or otherwise without the prior permission of Philips.



## TECHNICAL SPECIFICATION

### Sound

- Total Sound Power (RMS): 280 W
- Output Power: 3600W PMPO
- Sound Enhancement: MAX Sound, Dynamic Bass Boost 3 steps, Digital Sound Control 4 modes, Incredible Surround, Virtual Ambience Control
- Output power (RMS): 4 x 70W / ch

### Loudspeakers

- Main Speaker: 2 way, 2" tweeter, Bass Reflex Speaker System, 6.5" woofer
- Number of Loudspeakers: 2

### Audio Playback

- Loader Type: 3 CD Carousel
- Number of Discs: 3
- Playback Media: CD, CD-R, CD-RW, MP3-CD, WMA-CD
- USB Direct Modes: Delete, Fast Backward/Fast Forward, Play/Pause, Previous/Next, Repeat, Shuffle, Stop
- Disc Playback Modes: Repeat/one/disk/program, Shuffle Play, 40-Track Programmable

### Audio Recording

- Recording Media: USB device
- USB recording modes: Instant record, Programmed tracks, Schedule radio program, Single disc, Single track
- USB recording sources: Aux, CD, Tuner, Microphone in

### Tuner/Reception/Transmission

- Auto digital tuning
- Station presets: 40
- Tuner Bands: MW, FM Stereo
- Tuner Enhancements: Auto Store, Easy Set (Plug & Play)

### Connectivity

- Microphone: Dual Microphone sockets
- Other connections: FM Antenna, MW Antenna, AM Antenna
- USB: USB host
- Audio Connections: RCA Aux in, 3.5mm stereo line in -MP3 link

### Convenience

- Alarms: CD Alarm, USB alarm, Radio Alarm, Sleep timer
- Clock: On main display
- Display Type: LCD
- Karaoke: MIC volume, Echo control

### Accessories

- Included accessories: FM/MW Antenna, \*Flat pin adaptor, Batteries for remote control, AC Power Cord
- Remote control: 36-key with 2xAAA batteries
- Guarantee booklet: Global version
- User Manual: Spanish, B-Portuguese
- Quick start guide: Spanish, B-Portugues
- Cables: MP3 Line in Cable

### Dimensions

- Set dimensions (W x H x D): 265 x 310 x 390 mm
- Packaging dimensions (W x H x D): 900 x 440 x 326 mm
- Weight incl. Packaging: 15.92 kg
- Speaker Depth: 273 mm
- Speaker Height: 358 mm
- Speaker Width: 230 mm

### Power

- Power supply: 100-240VAC, 50/60Hz

## VERSION VARIATION

Type /Versions:	FWM462									
	/55	/00		/77	/BK	/93	/94			/98
Board in used:										
AC BOARD	C/M			C/M	C/M					
MAIN BOARD	C/M			C/M	C/M					
TUNER BOARD	C/M			C/M	C/M					
AMP & POWER BOARD	C/M			C/M	C/M					
DISPLAY BOARD	C/M			C/M	C/M					
CD BOARD	C/M			C/M	C/M					
MCU BOARD	C/M			C/M	C/M					
Type /Versions:	FWM462									
Feature difference	/55	/00		/77	/BK	/93	/94			/98
RDS										
VOLTAGE SELECTOR										
ECO STANDBY - DARK										
* TIPS : C -- Component Lever Repair. M -- Module Lever Repair √ -- Used										

# MEASUREMENT SETUP

## Tuner FM

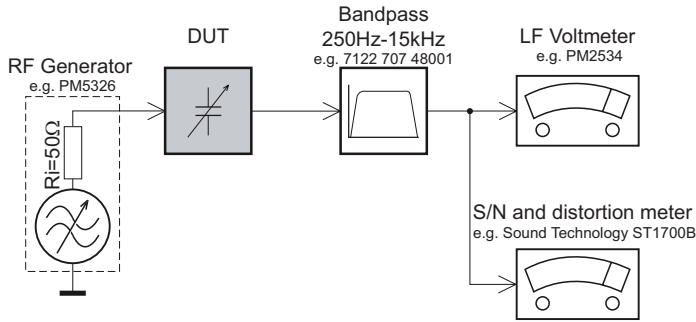

Use a bandpass filter to eliminate hum (50Hz, 100Hz) and disturbance from the pilotone (19kHz, 38kHz).

## Tuner AM (MW,LW)

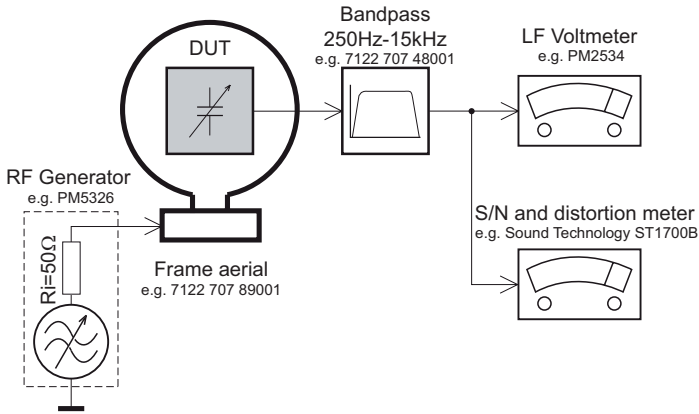

To avoid atmospheric interference all AM-measurements have to be carried out in a Faraday's cage. Use a bandpass filter (or at least a high pass filter with 250Hz) to eliminate hum (50Hz, 100Hz).

## CD

Use Audio Signal Disc SBC429 4822 397 30184  
(replaces test disc 3)

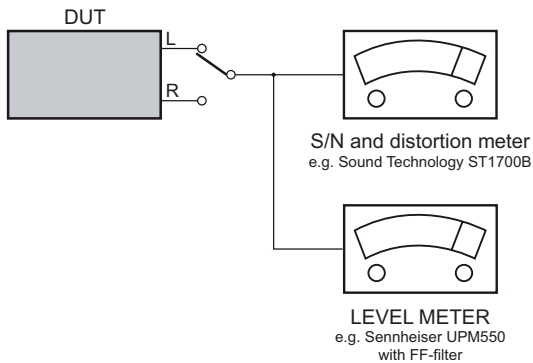

## Recorder

Use Universal Test Cassette **Cr02** SBC419 4822 397 30069  
or Universal Test Cassette **Fe** SBC420 4822 397 30071

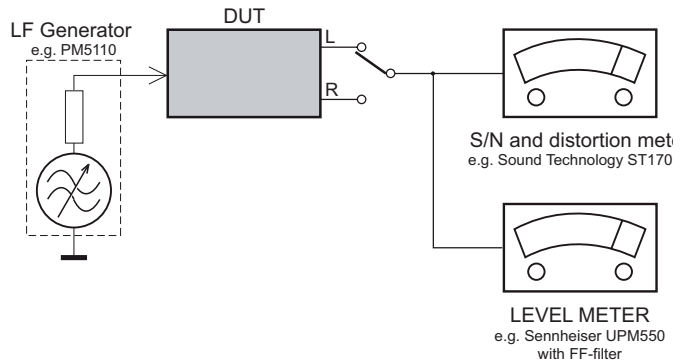

## SERVICE AIDS

### **GB** WARNING

All ICs and many other semi-conductors are susceptible to electrostatic discharges (ESD). Careless handling during repair can reduce life drastically.

When repairing, make sure that you are connected with the same potential as the mass of the set via a wrist wrap with resistance. Keep components and tools also at this potential.

### ESD



### **GB**

Safety regulations require that the set be restored to its original condition and that parts which are identical with those specified, be used

Safety components are marked by the symbol  $\Delta$ .

**CLASS 1  
LASER PRODUCT**

## INFORMATION ABOUT LEAD-FREE SOLDERING

Philips CE is producing lead-free sets from 1.1.2005 onwards.

### IDENTIFICATION:

Regardless of special logo (not always indicated) one must treat all sets from 1 Jan 2005 onwards, according next rules:



- On our website [www.atyourservice.ce.Philips.com](http://www.atyourservice.ce.Philips.com) you find more information to:
  - \* BGA-de-/soldering (+ baking instructions)
  - \* Heating-profiles of BGAs and other ICs used in Philips-sets
  - \* Lead free

You will find this and more technical information within the "magazine", chapter "workshop news".

For additional questions please contact your local repair-helpdesk.

## SERVICE INSTRUCTION

Safety regulations require that after a repair, the set must be returned in its original condition. Pay in particular attention to the following points:

- Route the wire trees correctly and fix them with the mounted cable clamps.
- Check the insulation of the AC Power lead for external damage.
- Check the strain relief of the AC Power cord for proper function.
- Check the electrical DC resistance between the AC Power Plug and the secondary side (only for sets which have a AC Power isolated power supply):
  1. Unplug the AC Power cord and connect a wire between the two pins of the AC Power plug.
  2. Set the AC Power switch to the "on" position (keep the AC Power cord unplugged!).
  3. Measure the resistance value between the pins of the AC Power plug and the metal shielding of the tuner or the aerial connection on the set. The reading should be larger than 4.5 Mohm (For U.S. it should be between 4.2 Mohm and 12 Mohm).
  4. Switch "off" the set, and remove the wire between the two pins of the AC Power plug.
- Check the cabinet for defects, to avoid touching of any inner parts by the customer.

# INSTRUCTIONS ON CD PLAYABILITY

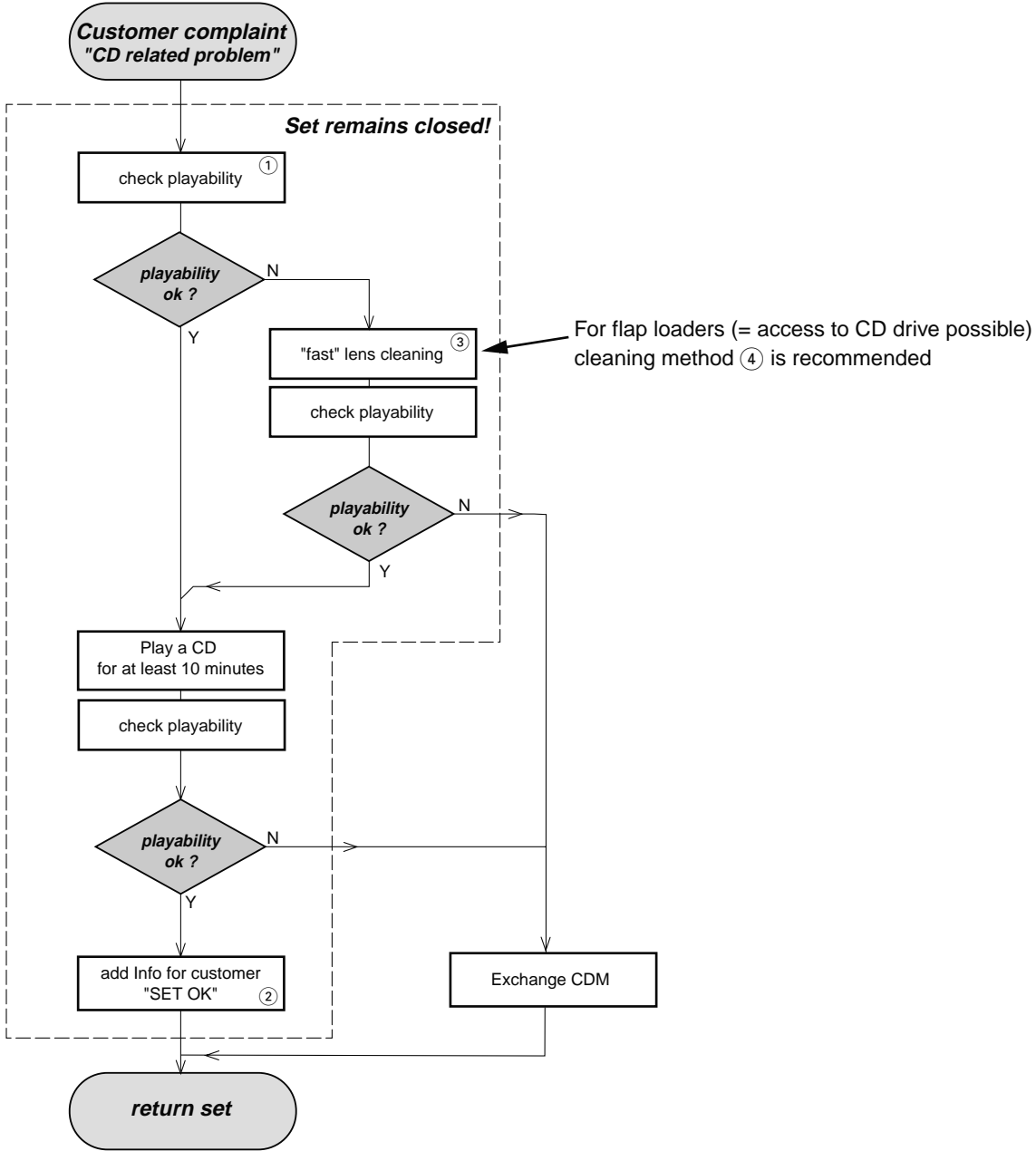

For flap loaders (= access to CD drive possible) cleaning method ④ is recommended

① - ④ For description - see following pages

## INSTRUCTIONS ON CD PLAYABILITY

①

### PLAYABILITY CHECK

For sets which are compatible with **CD-RW** discs  
 use CD-RW Printed Audio Disc .....7104 099 96611  
 TR 3 (Fingerprint)  
 TR 8 (600µ Black dot) **maximum at 01:00**

- playback of these two tracks without audible disturbance  
 playing time for: Fingerprint  $\geq 10$ seconds  
 Black dot from 00:50 to 01:10
- jump forward/backward (search) within a reasonable time

For all other sets  
 use CD-DA SBC 444A .....4822 397 30245  
 TR 14 (600µ Black dot) **maximum at 01:15**  
 TR 19 (Fingerprint)  
 TR 10 (1000µ wedge)

- playback of all these tracks without audible disturbance  
 playing time for: 1000µ wedge  $\geq 10$ seconds  
 Fingerprint  $\geq 10$ seconds  
 Black dot from 01:05 to 01:25
- jump forward/backward (search) within a reasonable time

②

### CUSTOMER INFORMATION

It is proposed to add an addendum sheet to the set which informs the customer that the set has been checked carefully - but no fault was found.  
 The problem was obviously caused by a scratched, dirty or copy-protected CD. In case problems remain, the customer is requested to contact the workshop directly.  
 The lens cleaning (method ③) should be mentioned in the addendum sheet.

The final wording in national language as well as the printing is under responsibility of the Regional Service Organizations.

④

### LIQUID LENS CLEANING

**Before touching the lens it is advised to clean the surface of the lens by blowing clean air over it. This to avoid that little particles make scratches on the lens.**

Because the material of the lens is synthetic and coated with a special anti-reflectivity layer, cleaning must be done with a non-aggressive cleaning fluid. It is advised to use "Cleaning Solvent"

The actuator is a very precise mechanical component and may not be damaged in order to guarantee its full function. Clean the lens gently (don't press too hard) with a soft and clean cotton bud moistened with the special lens cleaner.

The direction of cleaning must be in the way as indicated in the picture below.

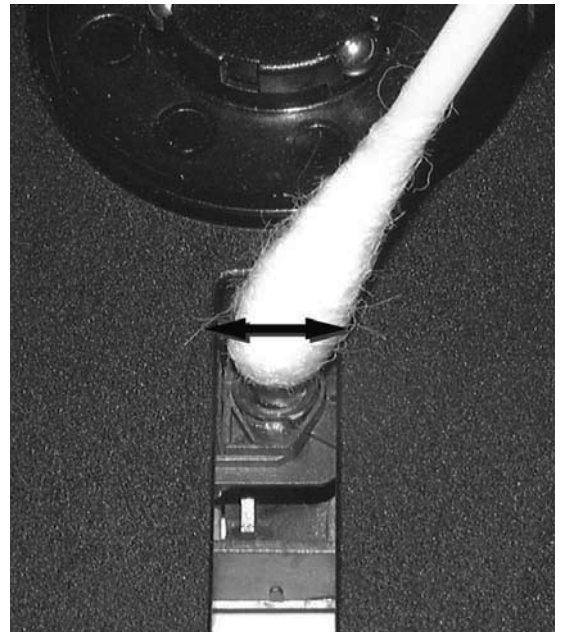

BLOCK DIAGRAM

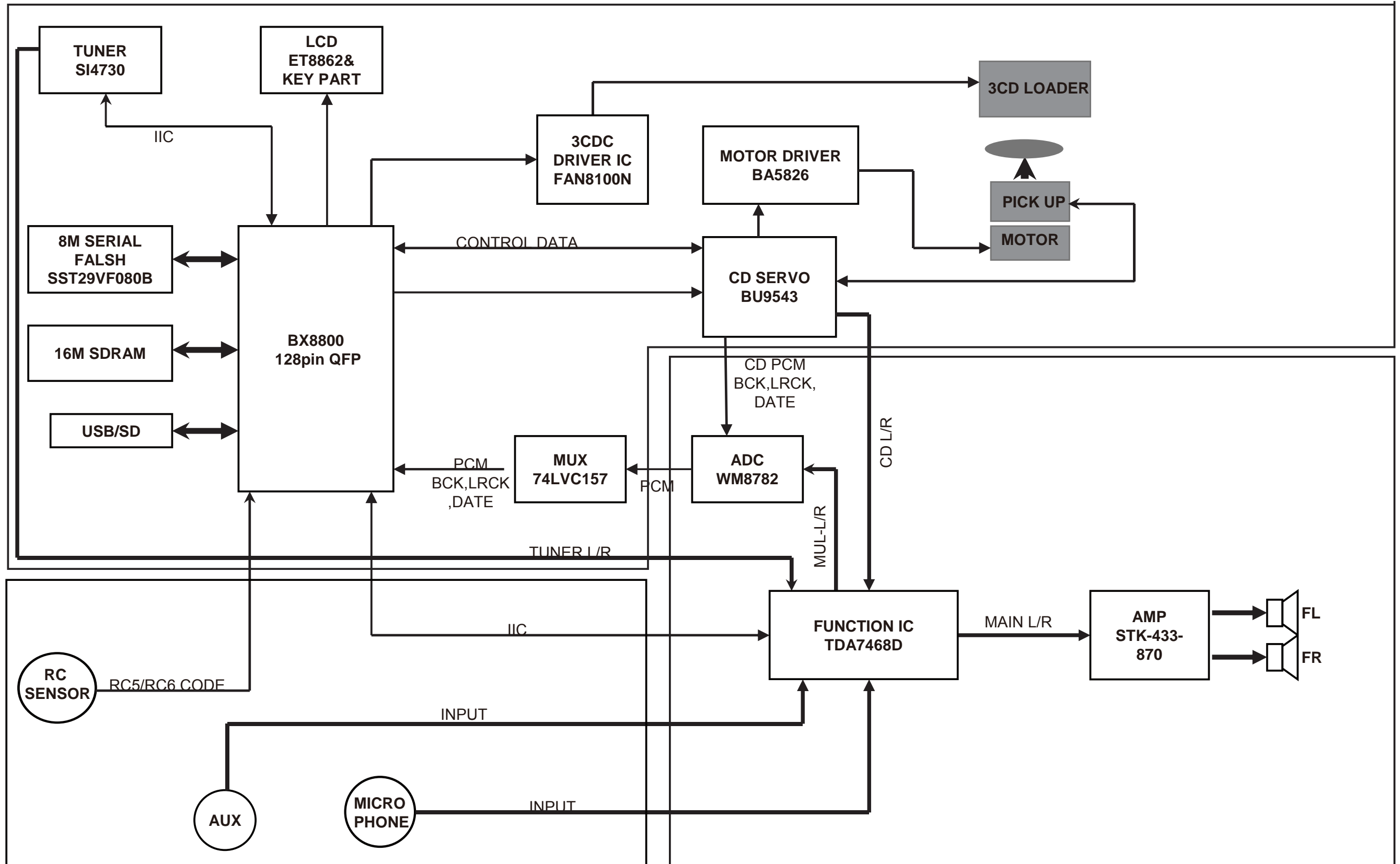

# WIRING DIAGRAM

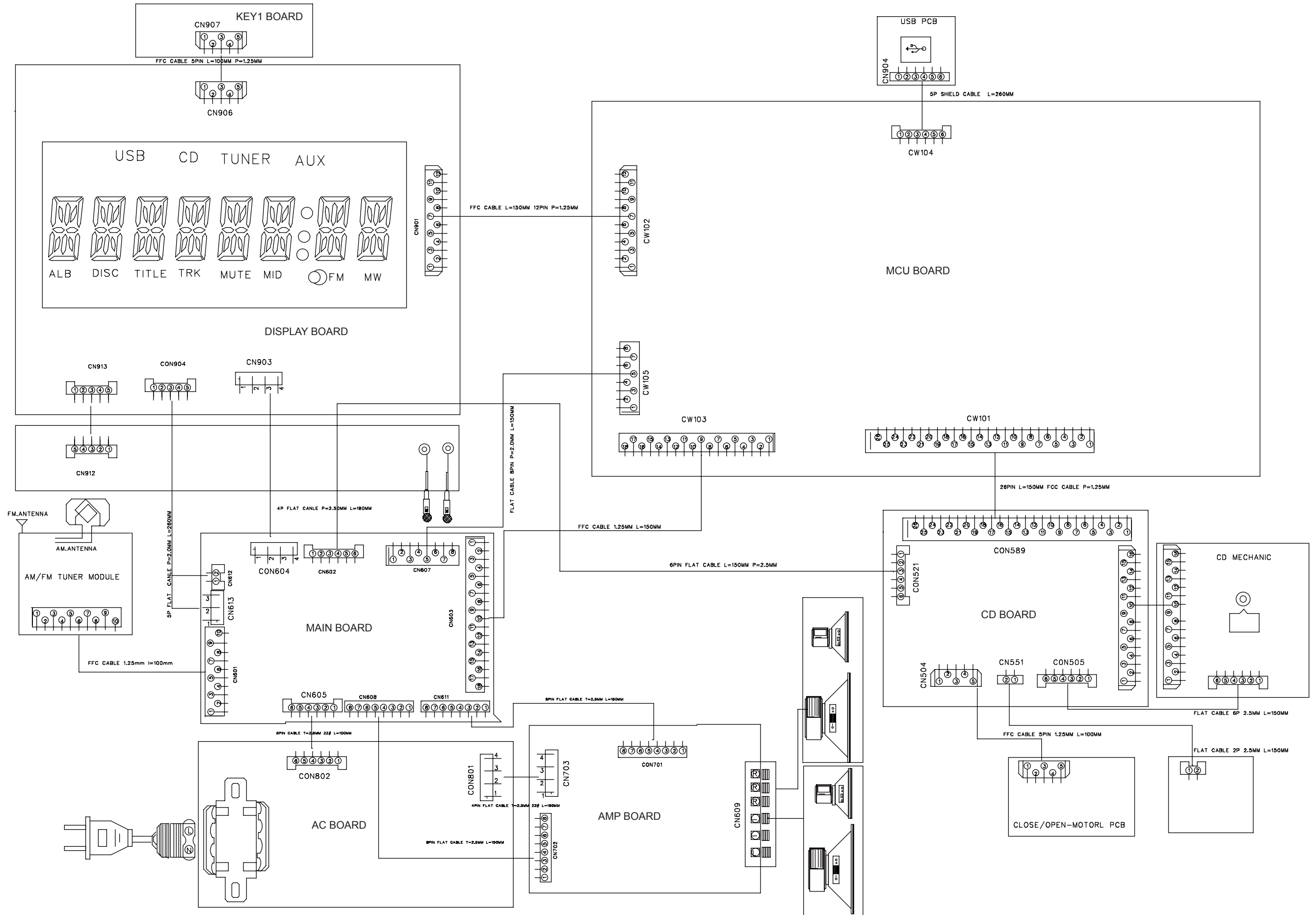



## DISMANTLING INSTRUCTIONS

### *Dismantling of the CDC Module and Front Panel*

- 1) Loosen 4 screws to remove the Cover Top of the set.
- 2) Loosen 2 screws to remove the Panel Left and 2 screws to remove the Panel Right of the set.
- 3) Slide out the CDC Tray as shown in the diagram below with the help of a flat head screw driver.

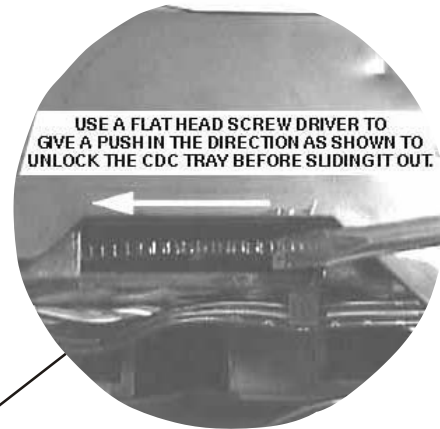
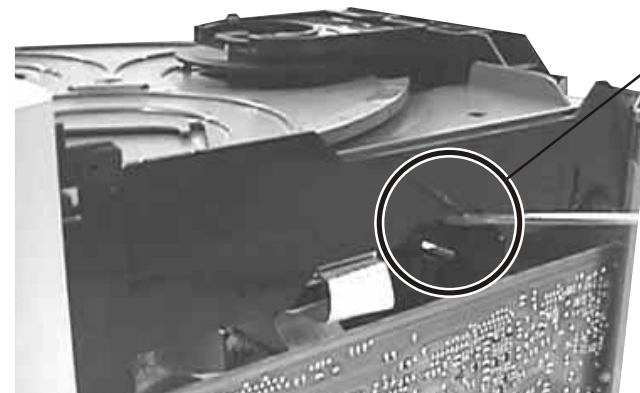

Sliding Out The CDC Tray

- 5) Loosen 2 screws A and 2 screws B to remove the CDC Module as indicated.
- 6) Remove 2 screws at the bottom to separate the Front Panel Assembly from the Plate Bottom.



Front View CDC

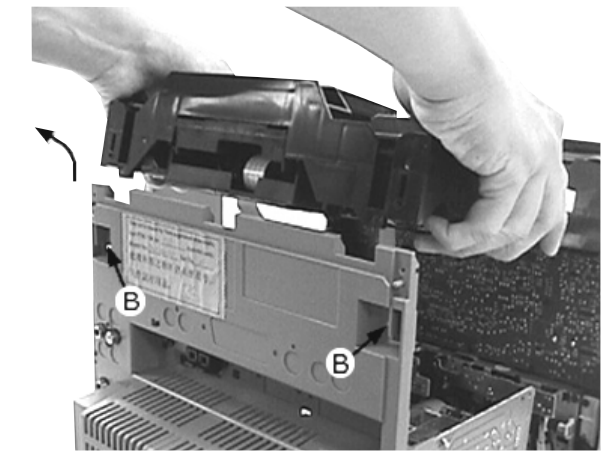

Remove CDC Module

- 4) Remove the Cover Tray CDC as indicated.

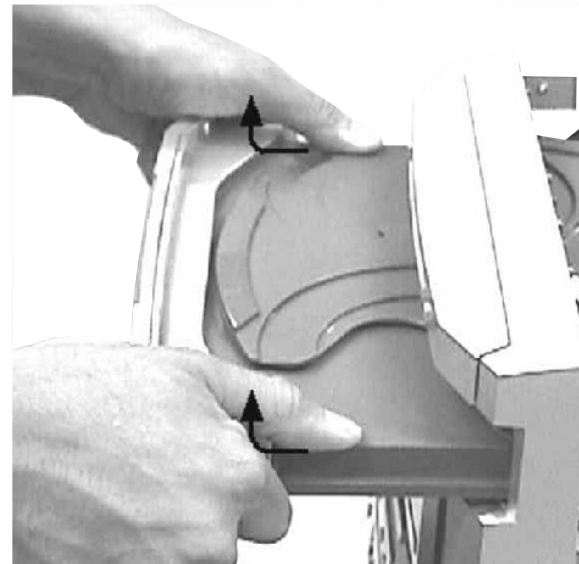

Remove Cover Tray CDC

### Dismantling of Rear Portion

- 1) Remove 2 screws C as indicated to loosen the Tuner Board.
- 2) Remove 4 screws D&H as indicated to loosen the Main Board.
- 3) Remove 6 screws E&I as indicated to loosen the Power Board.
- 4) Remove 3 screws F as indicated to loosen the Bottom Cabinet.
- 5) Remove 2 screws G as indicated to loosen the Front Cabinet.

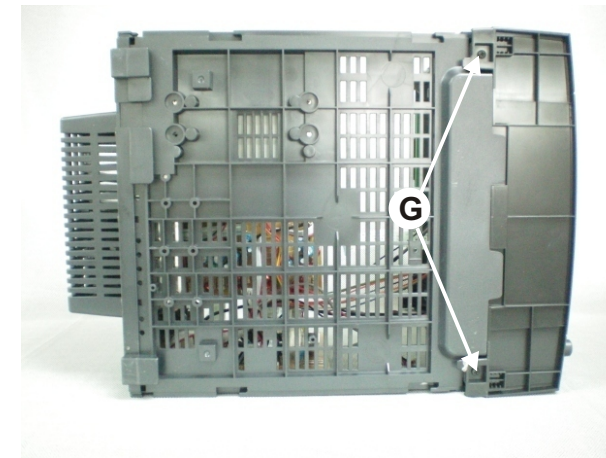
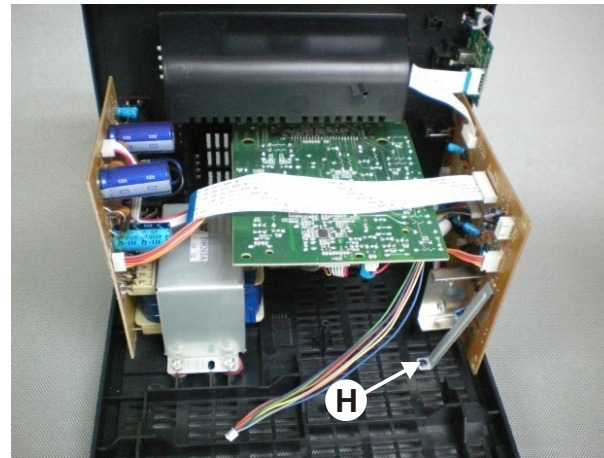
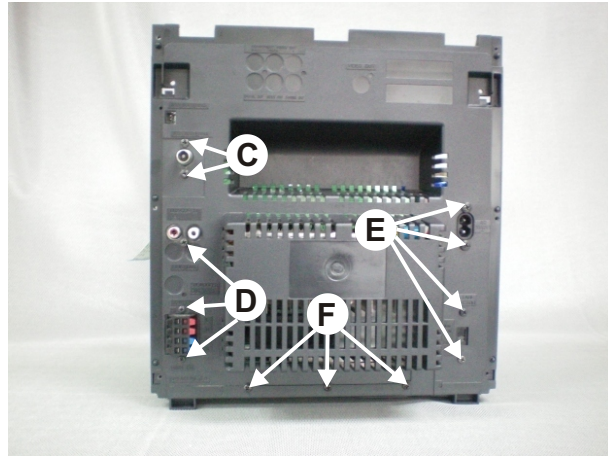

### Dismantling of the PCB Board

- 1) Remove 4 screws J as indicated to loosen the AMP Board.
- 2) Remove 27 screws K&L as indicated to loosen the KEY1&2 Board.
- 3) Remove 2 screws M as indicated to loosen the USB Board.

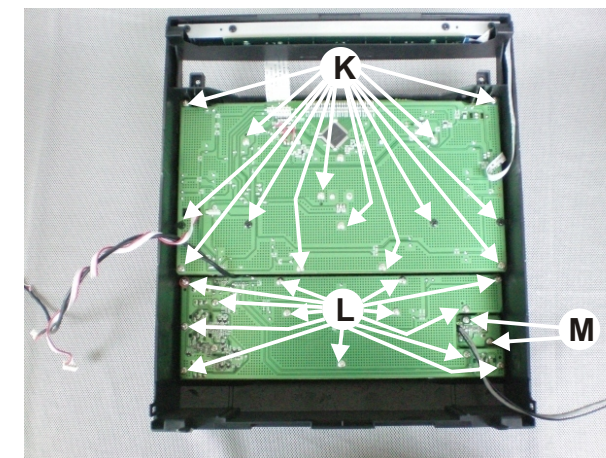
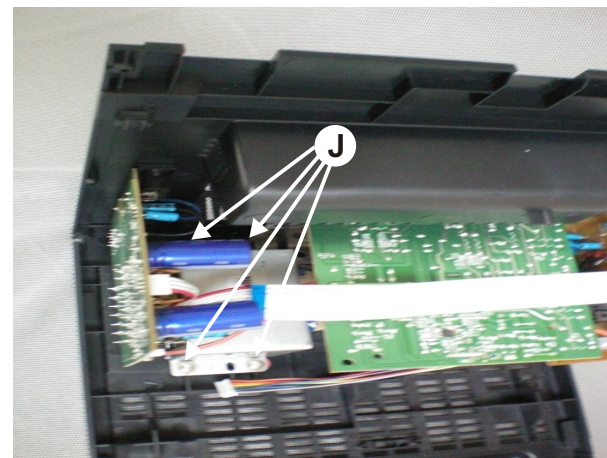
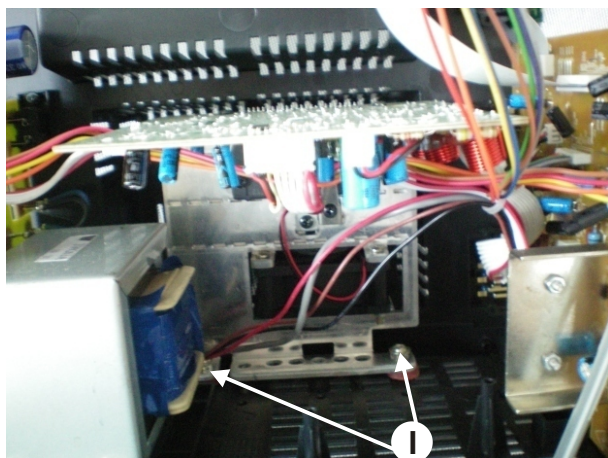

# CIRCUIT DIAGRAM - MAIN BOARD

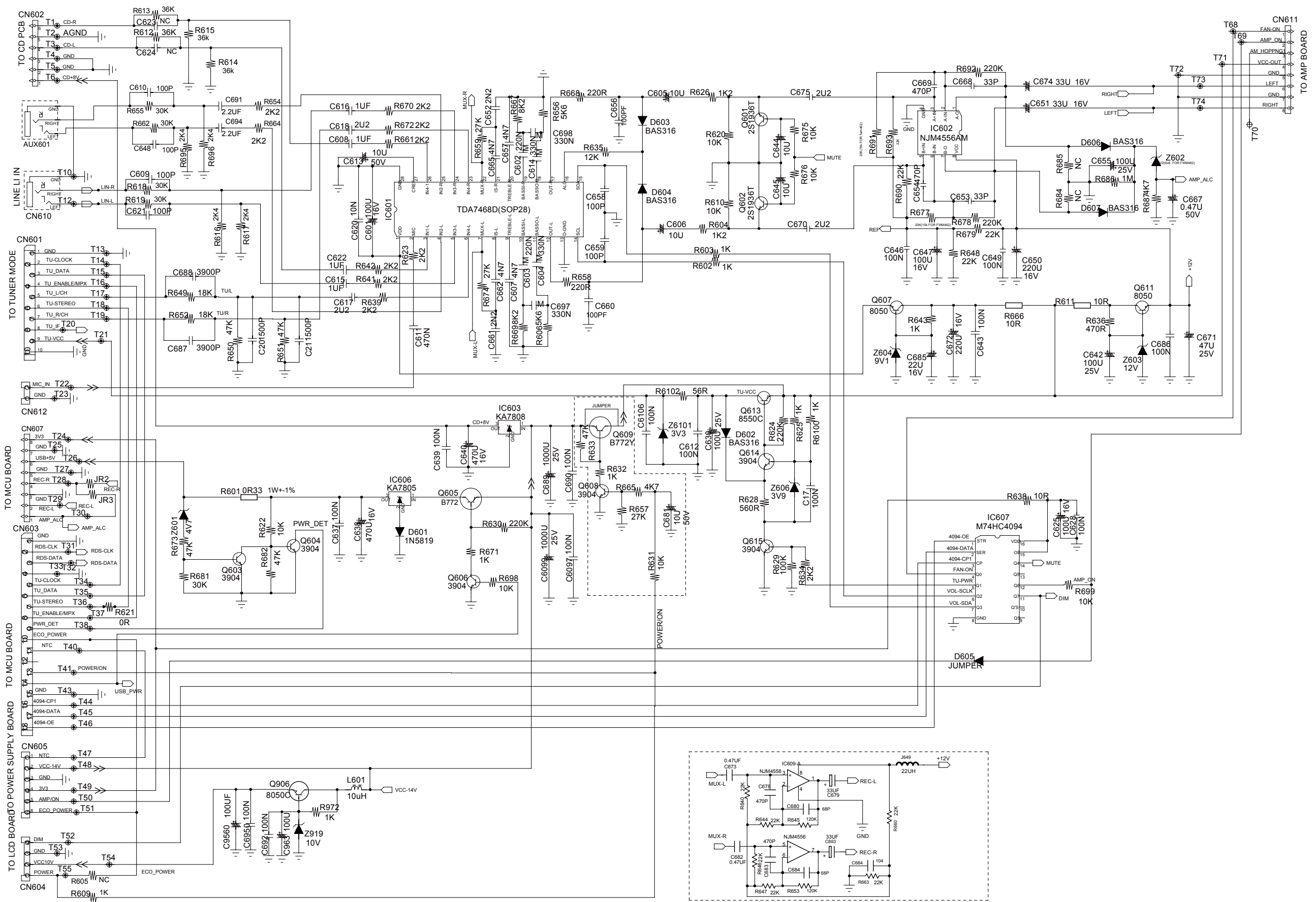

LAYOUT DIAGRAM - MAIN BOARD  
TOP SIDE

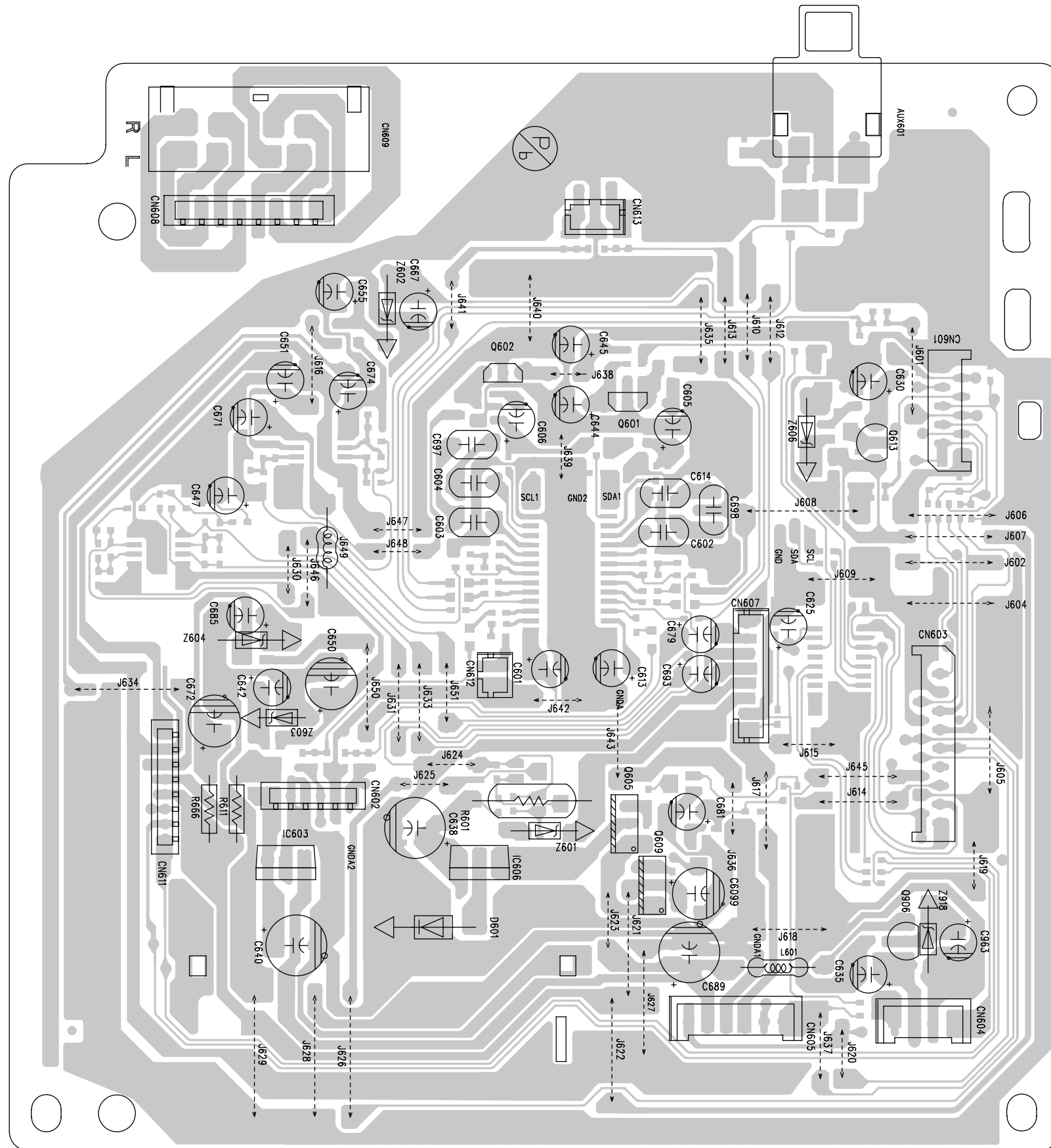

LAYOUT DIAGRAM - MAIN BOARD  
BOTTOM SIDE

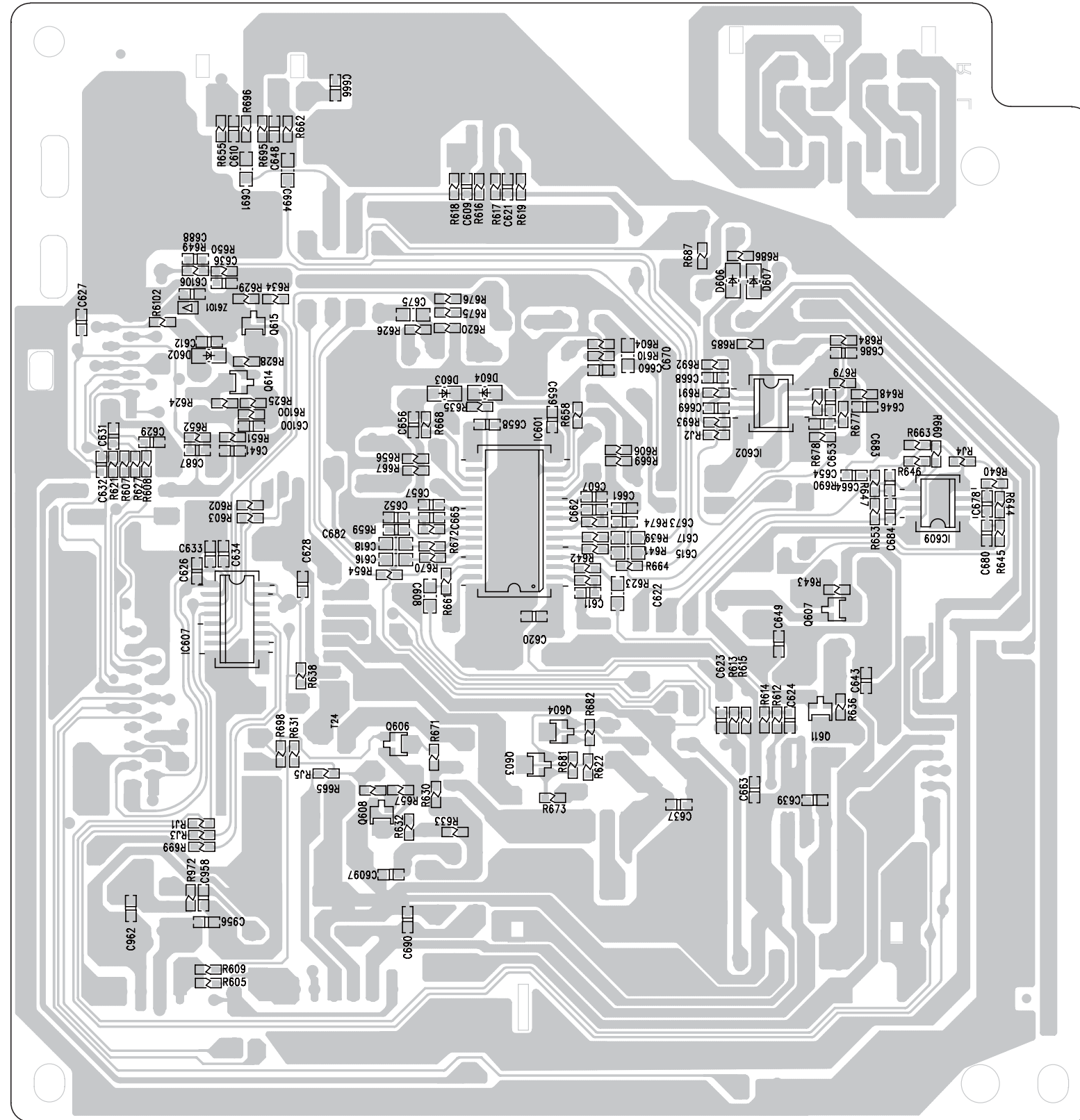

CIRCUIT DIAGRAM - AC BOARD

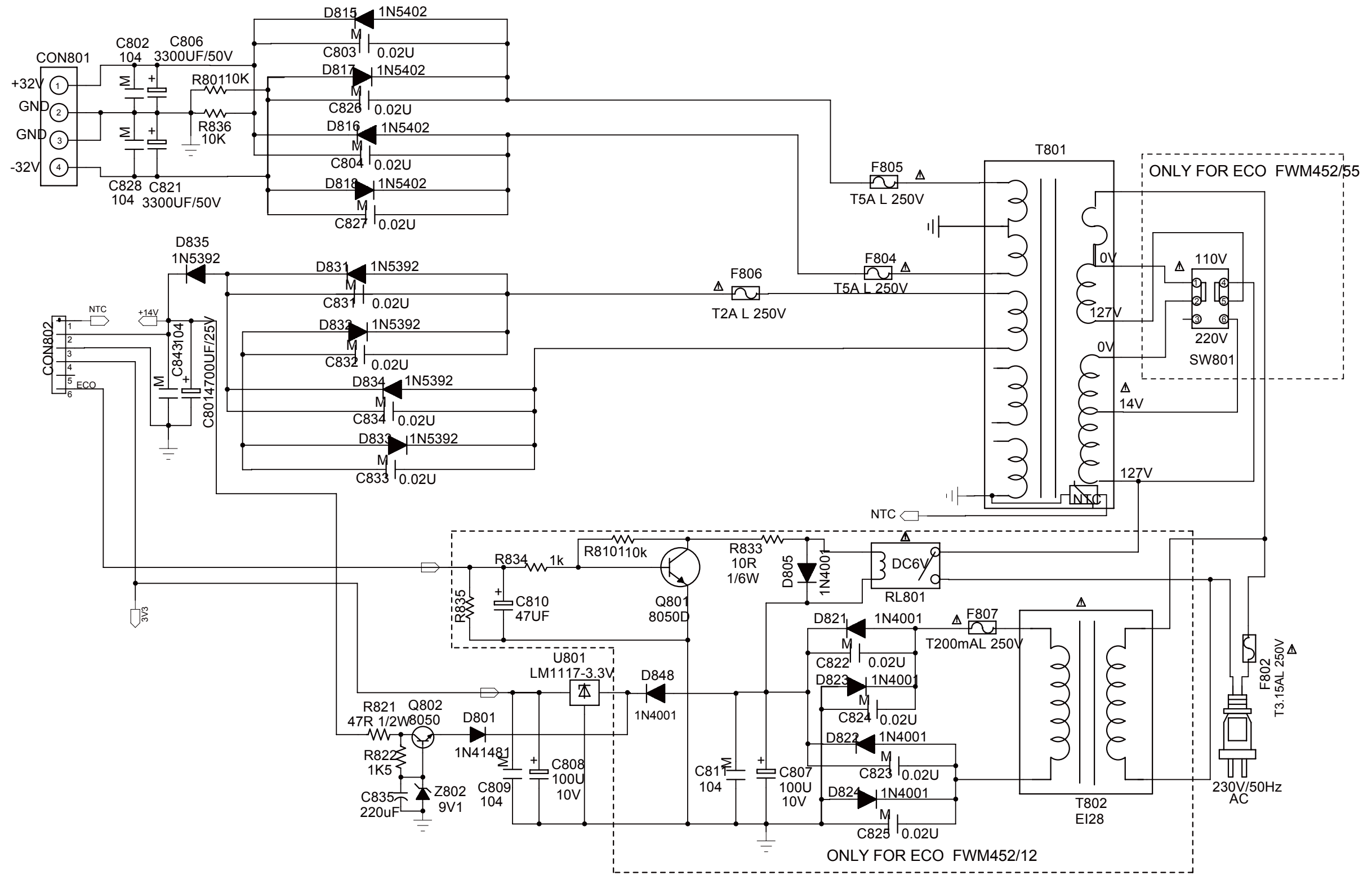

PCB LAYOUT - AC BOARD

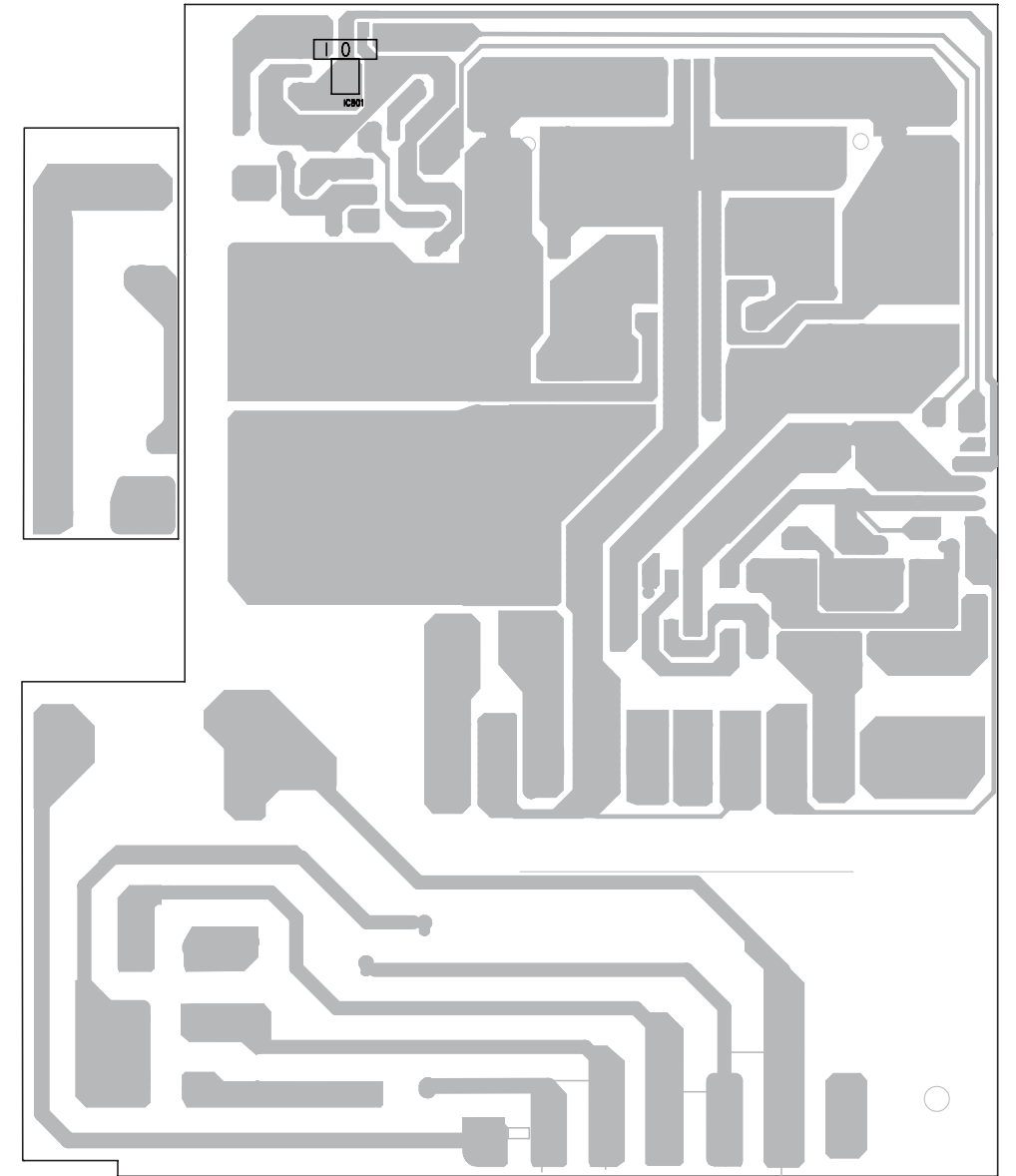
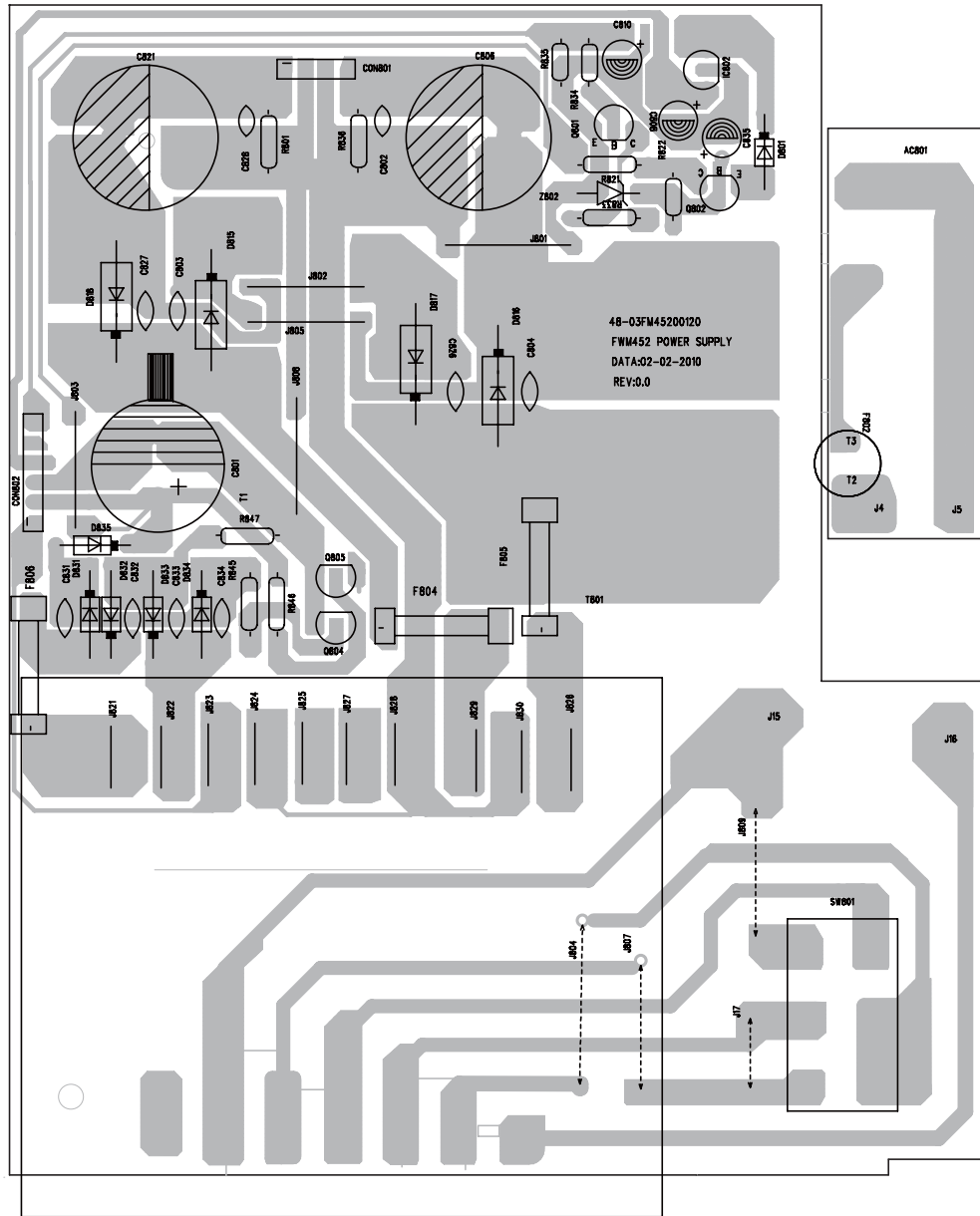

# CIRCUIT DIAGRAM - DISPLAY BOARD

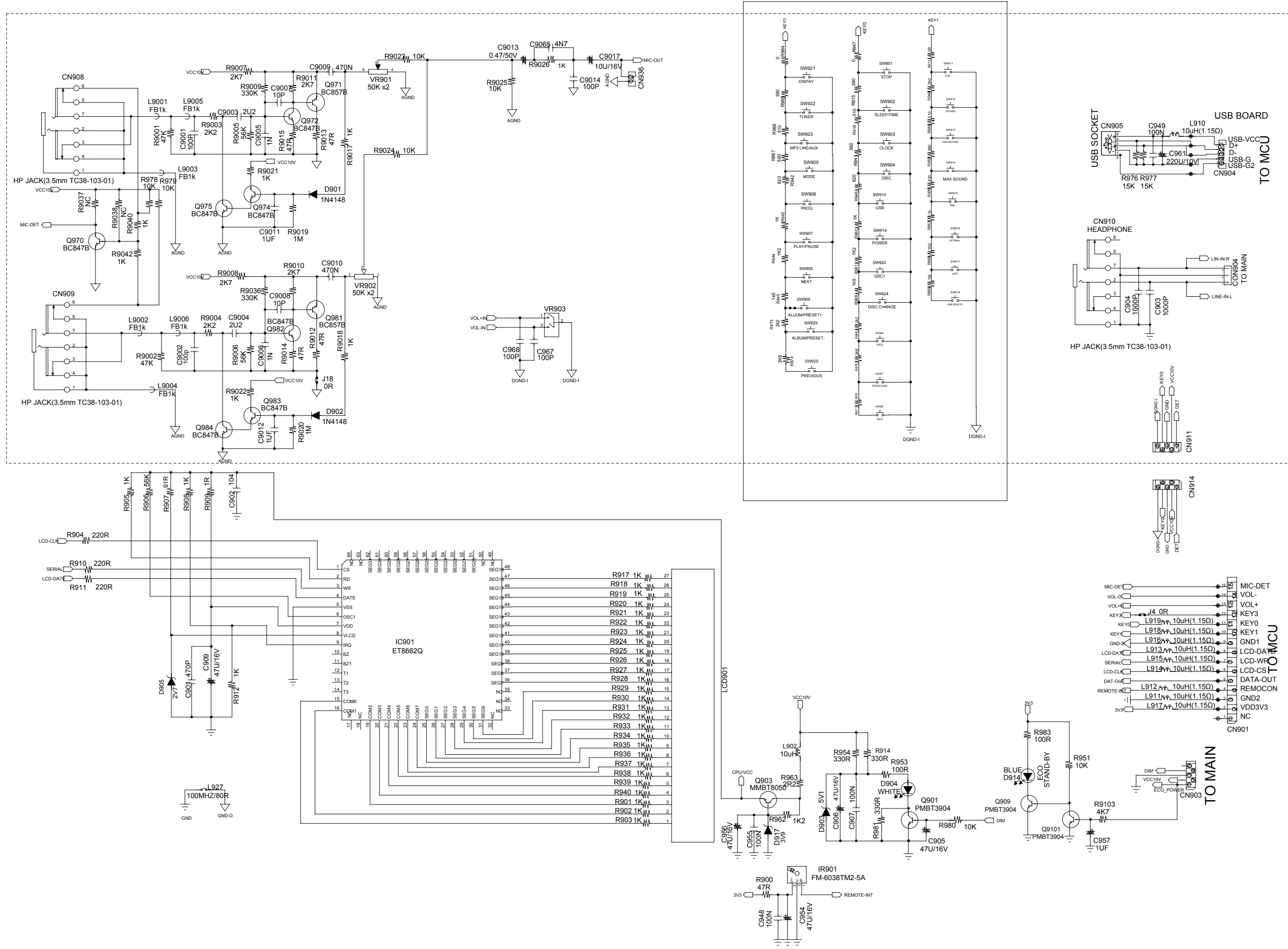



LAYOUT DIAGRAM - DISPLAY BOARD  
TOP SIDE

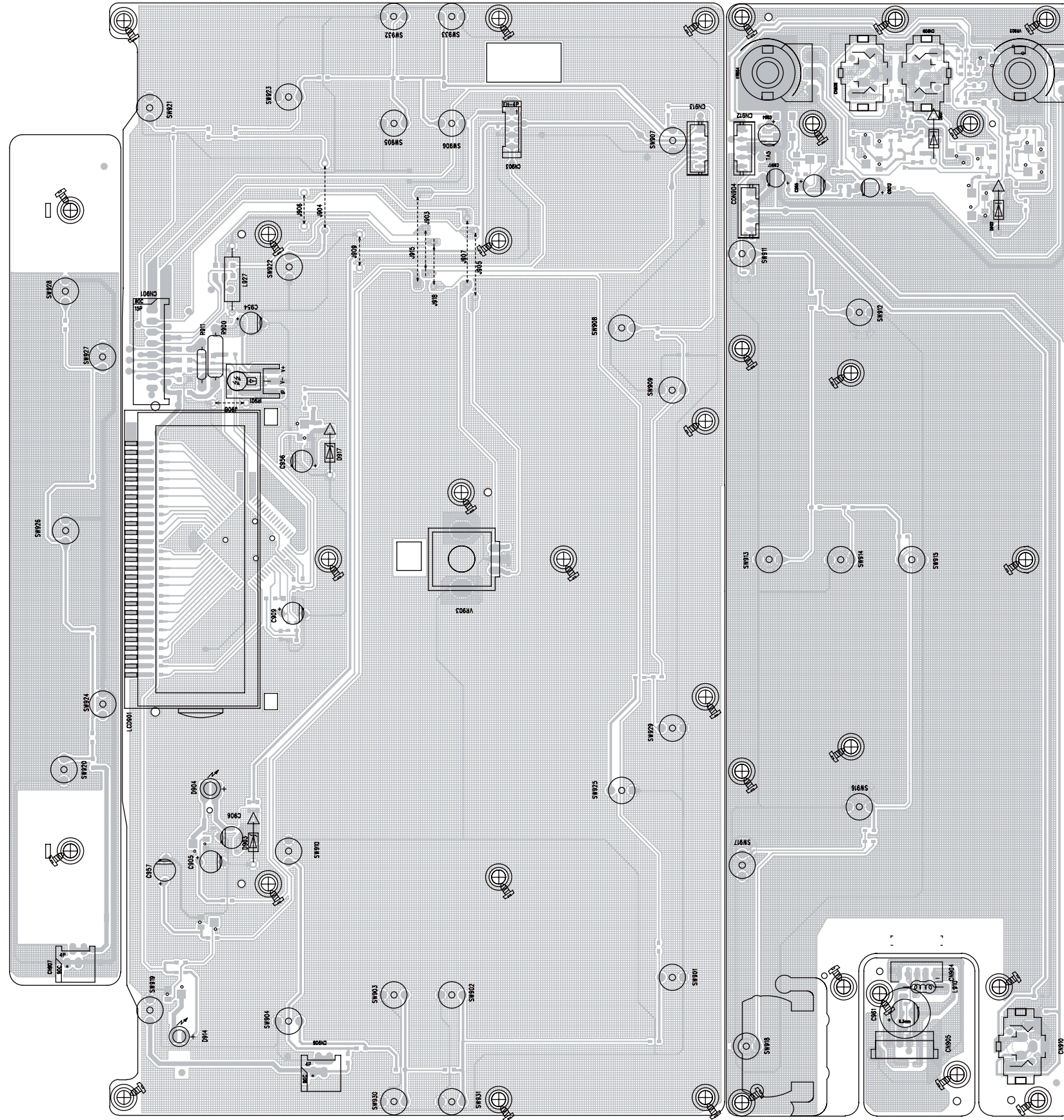

LAYOUT DIAGRAM - DISPLAY BOARD  
BOTTOM SIDE

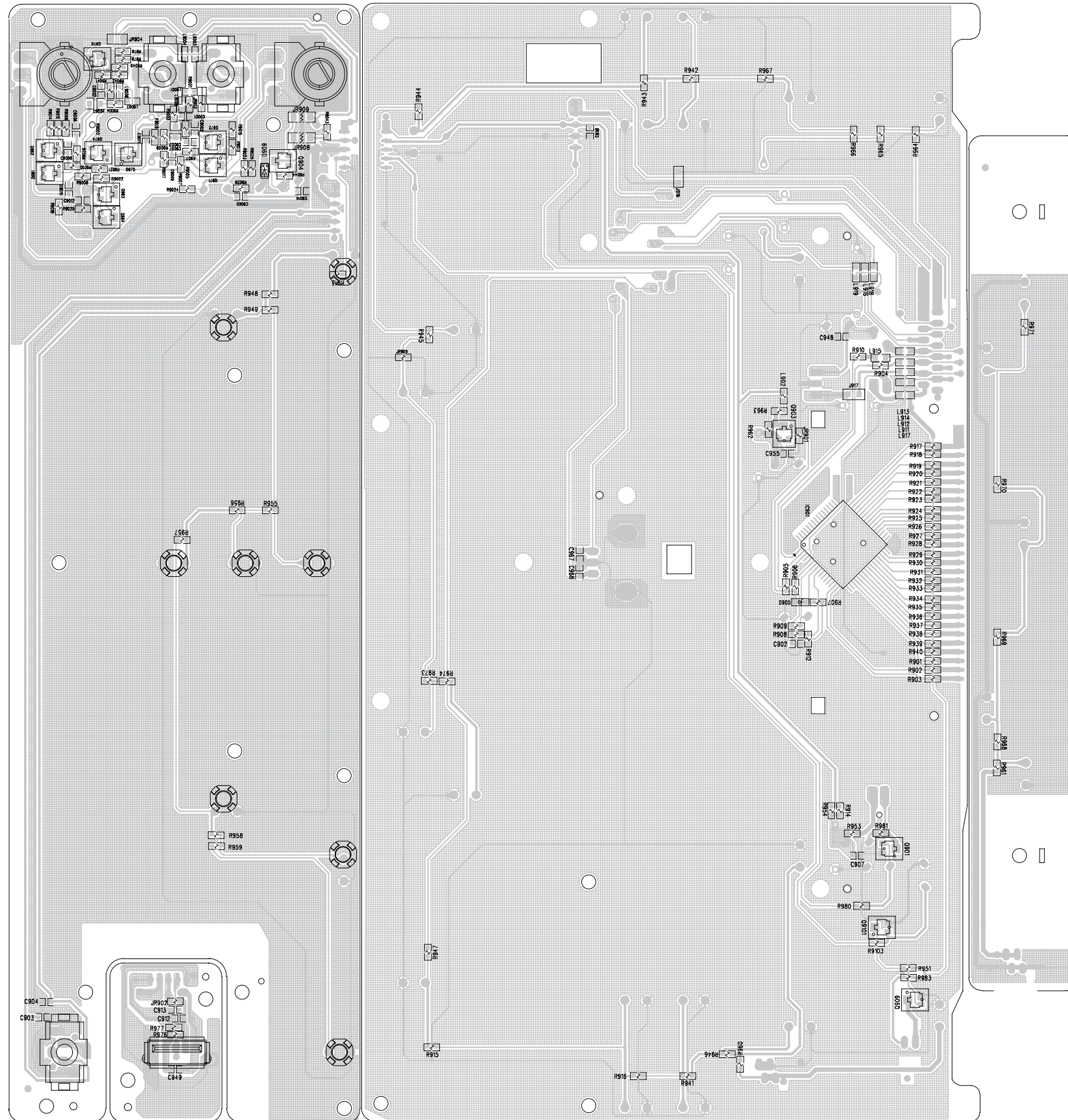

# CIRCUIT DIAGRAM - AMP BOARD

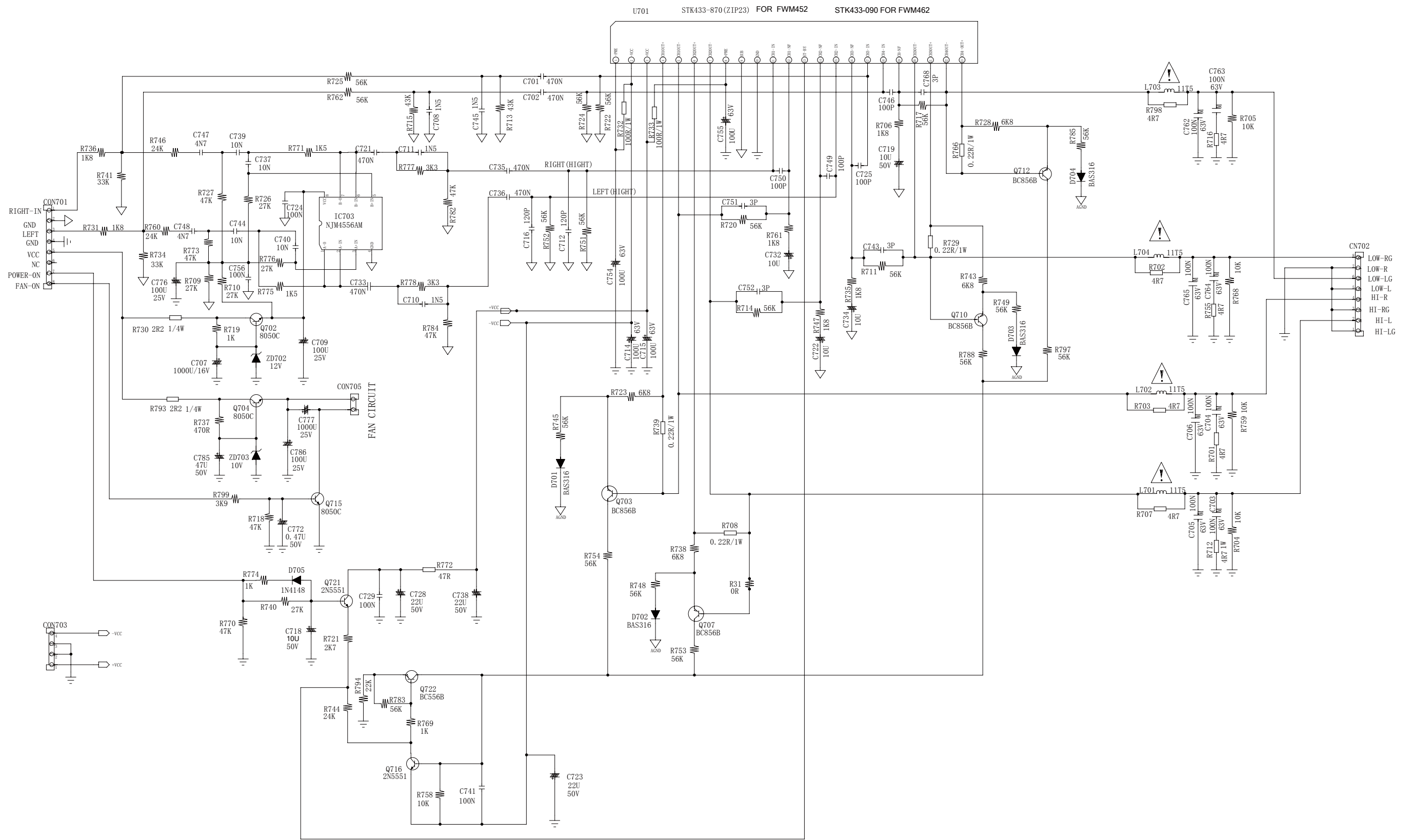

PCB LAYOUT - AMP BOARD  
TOP SIDE

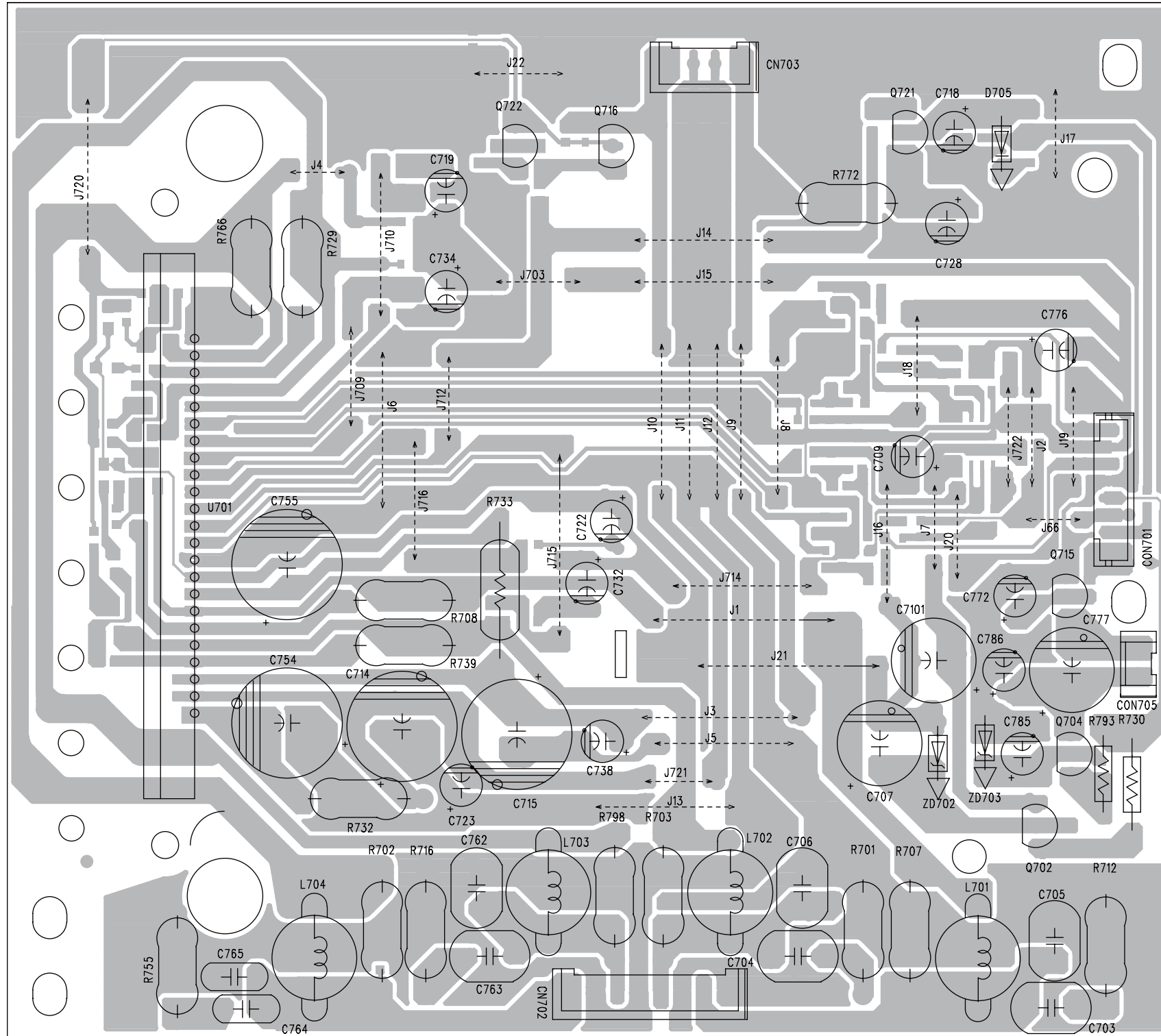

PCB LAYOUT - AMP BOARD  
BOTTOM SIDE

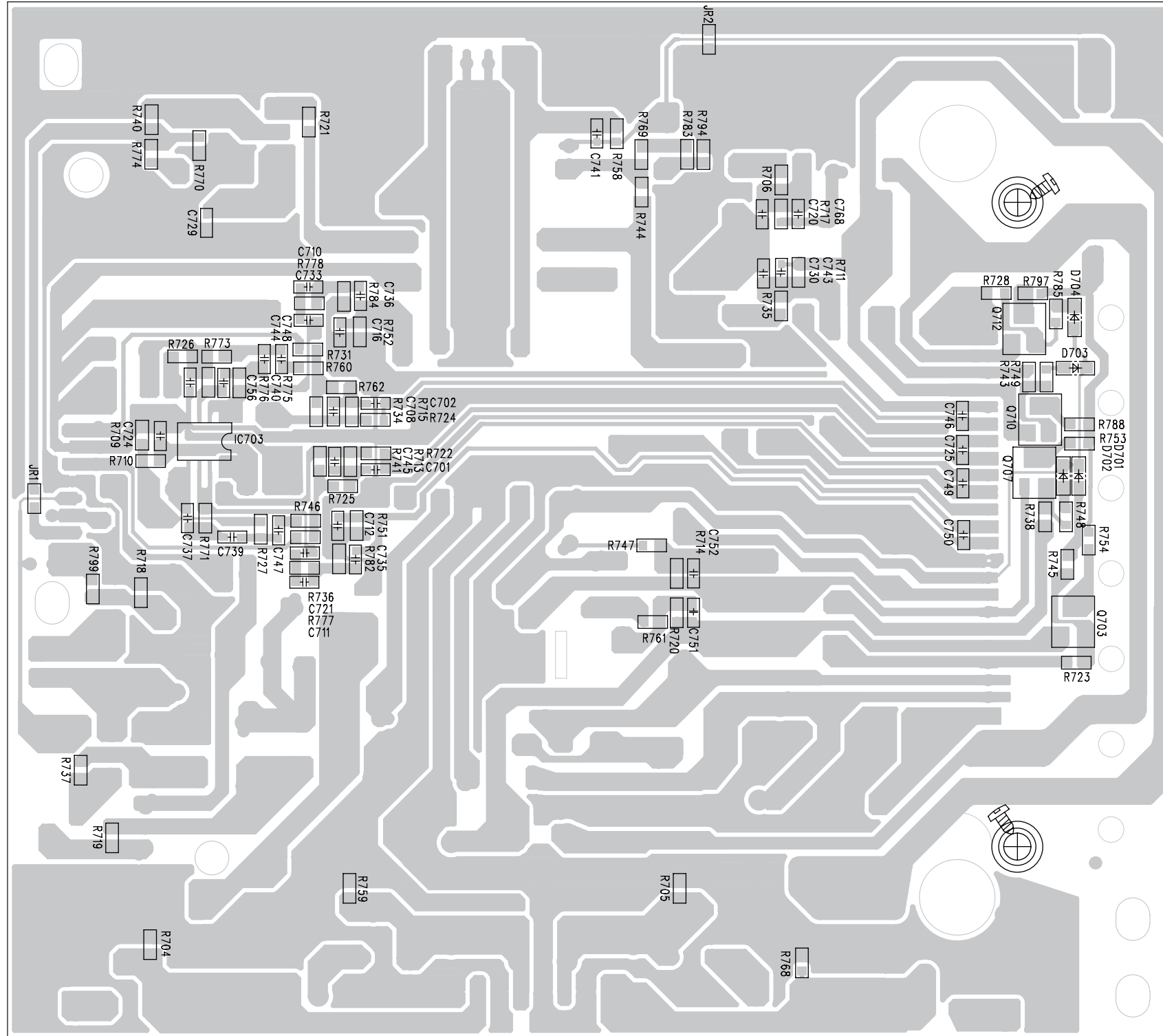

# CIRCUIT DIAGRAM - TUNER BOARD

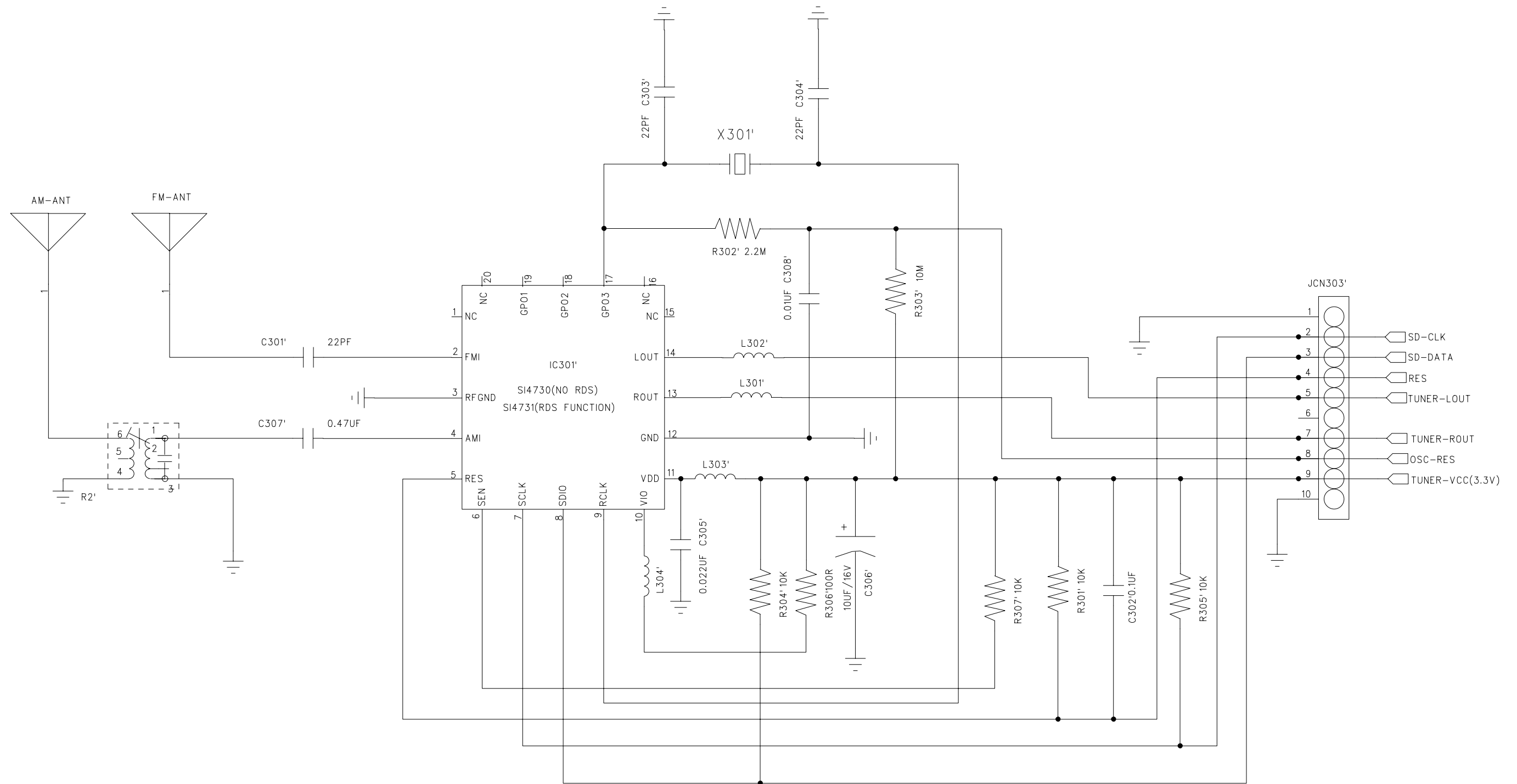

LAYOUT DIAGRAM - TUNER BOARD

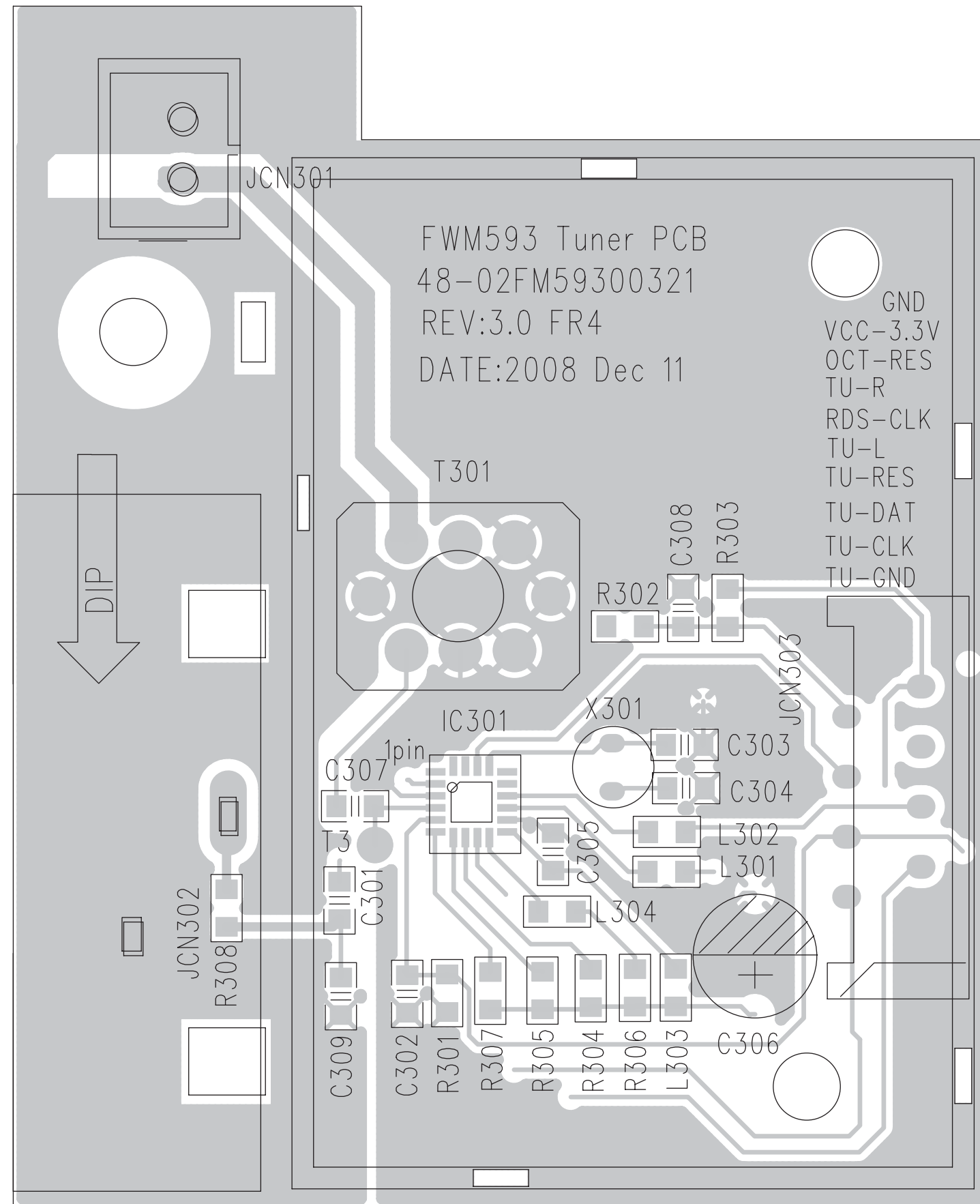

# CIRCUIT DIAGRAM-CD BOARD

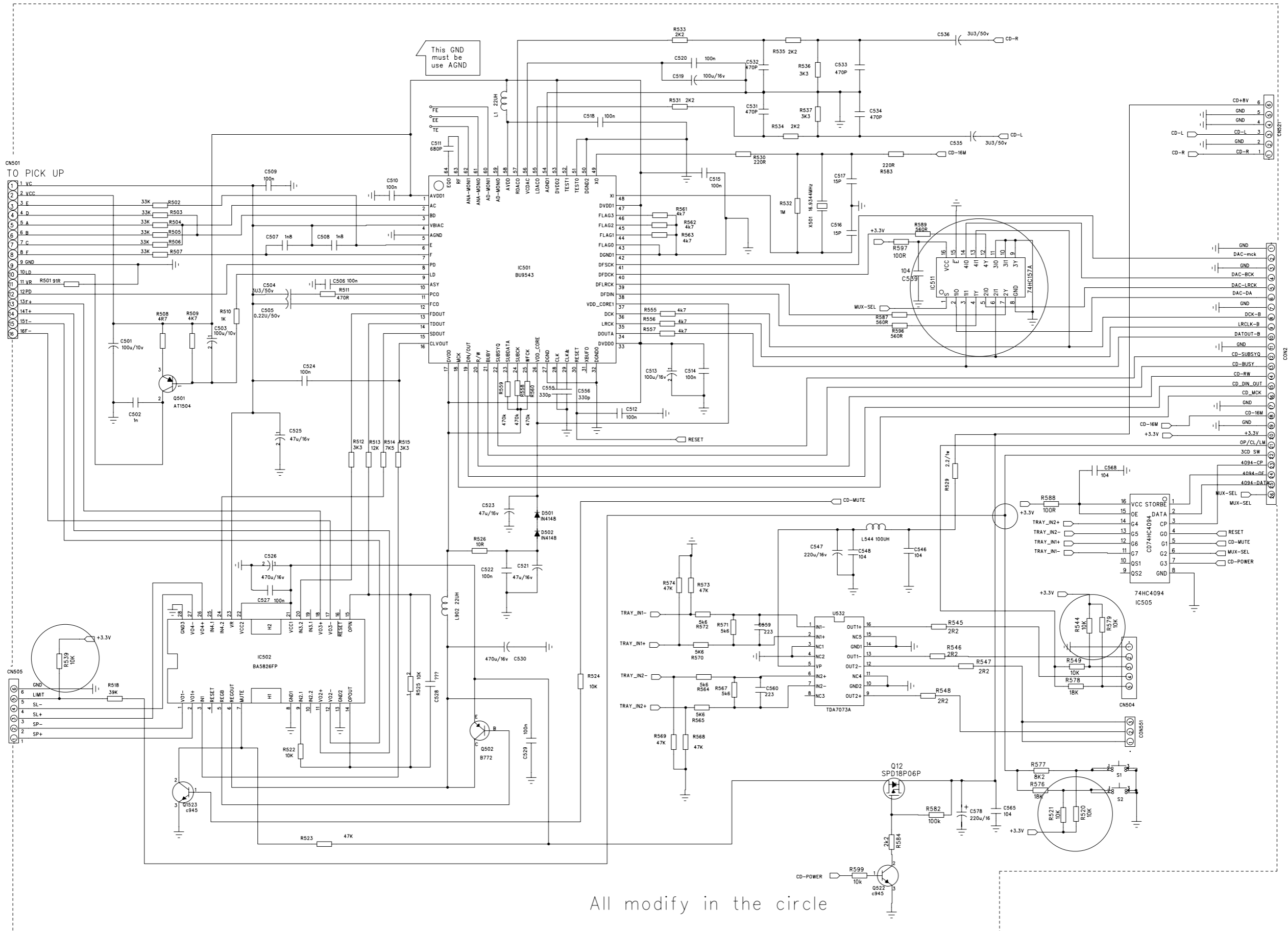



LAYOUT DIAGRAM-CD BOARD  
TOP SIDE

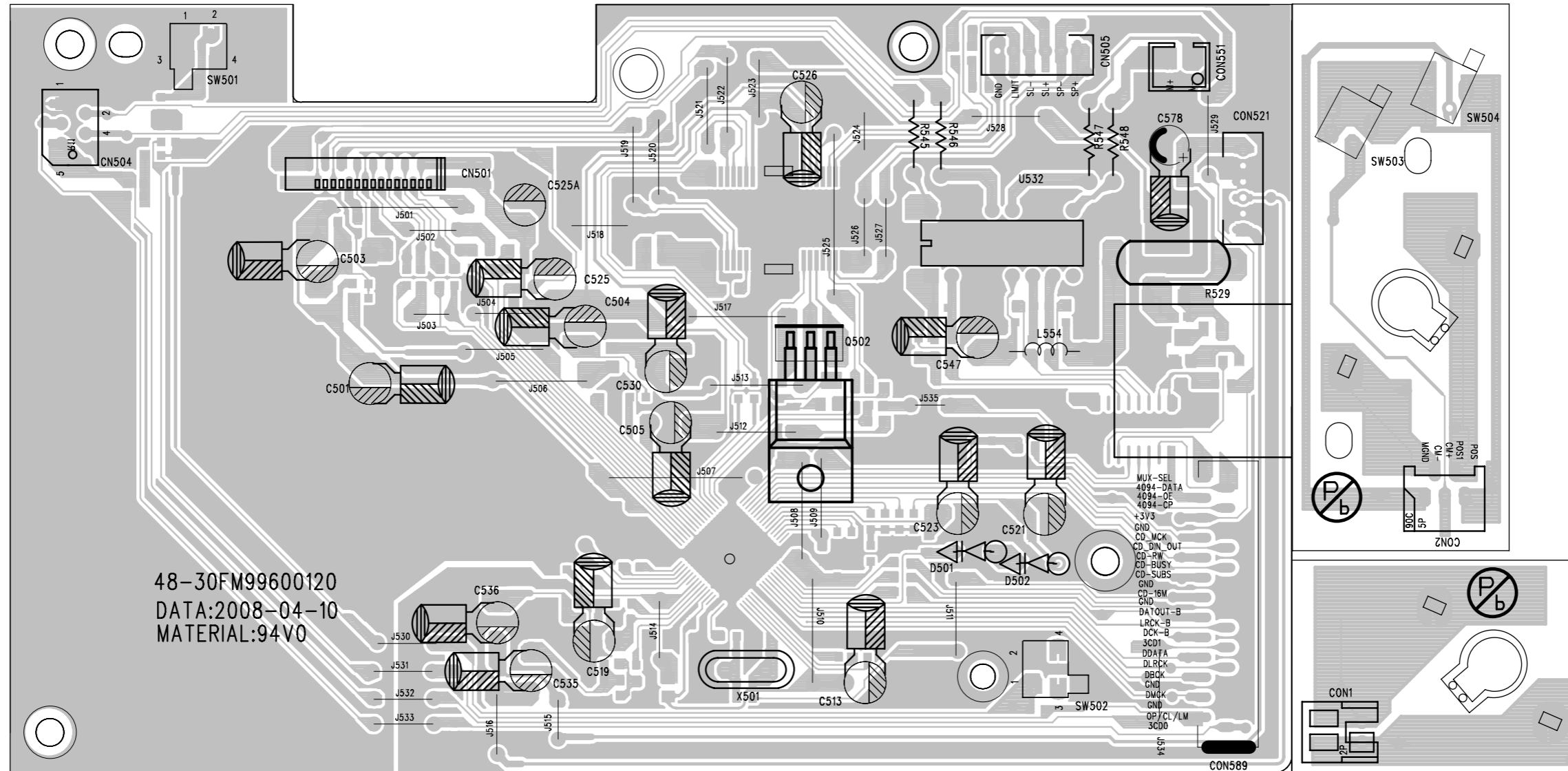

LAYOUT DIAGRAM-CD BOARD  
BOTTOM SIDE

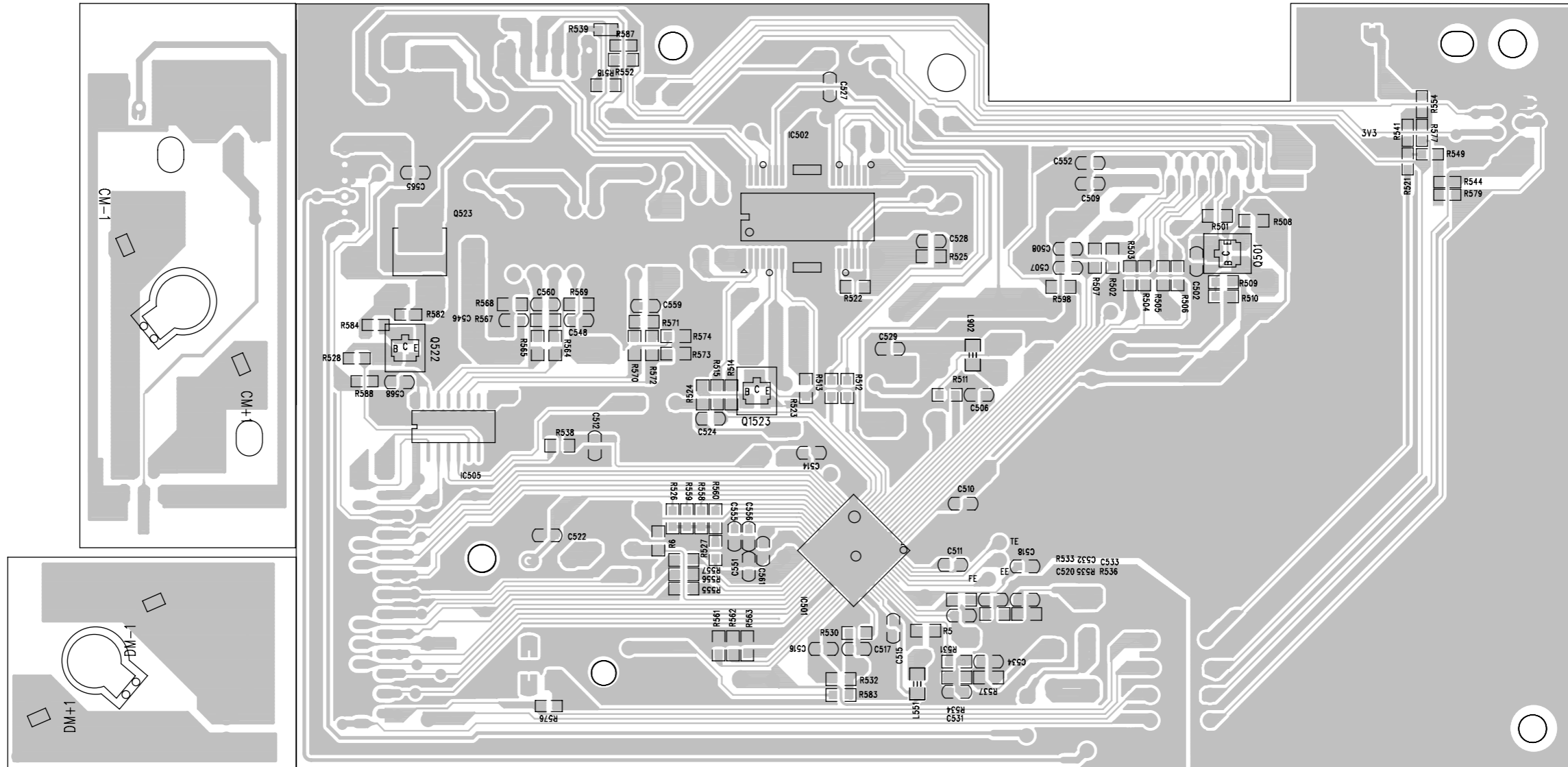

# CIRCUIT DIAGRAM - MCU BOARD PART1

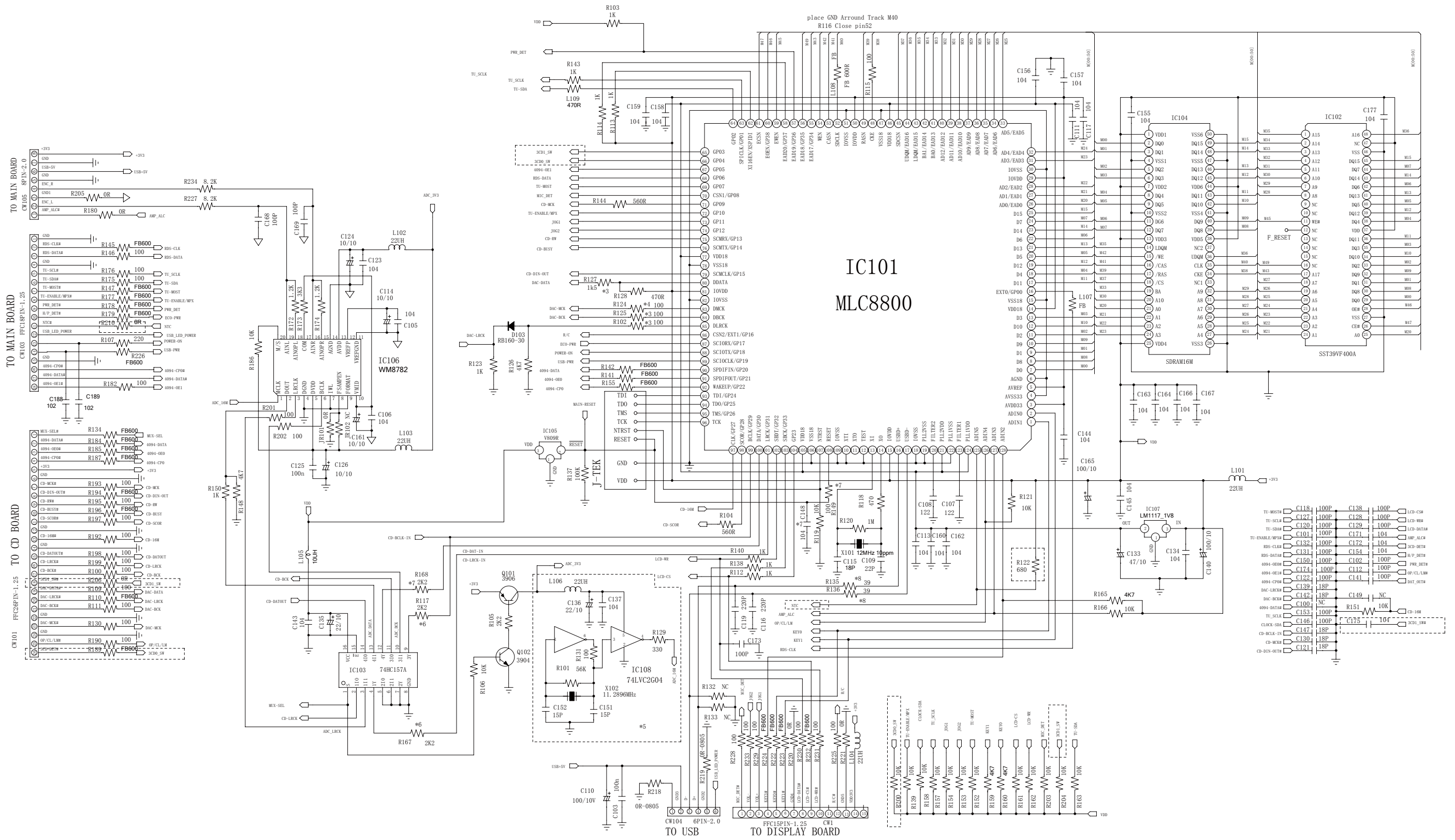

# CIRCUIT DIAGRAM - MCU BOARD PART2

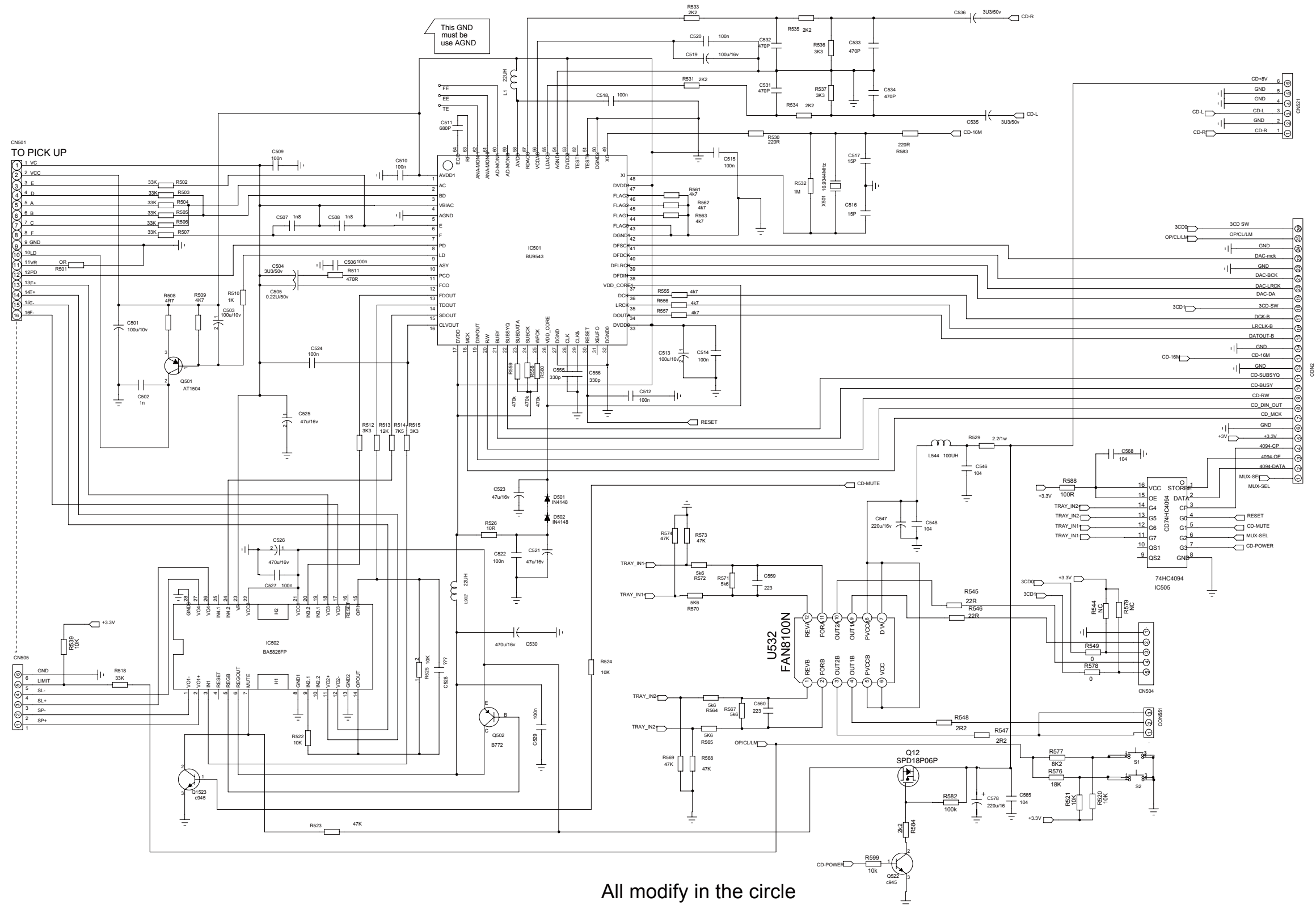

All modify in the circle

PCB LAYOUT - MCU BOARD  
TOP SIDE

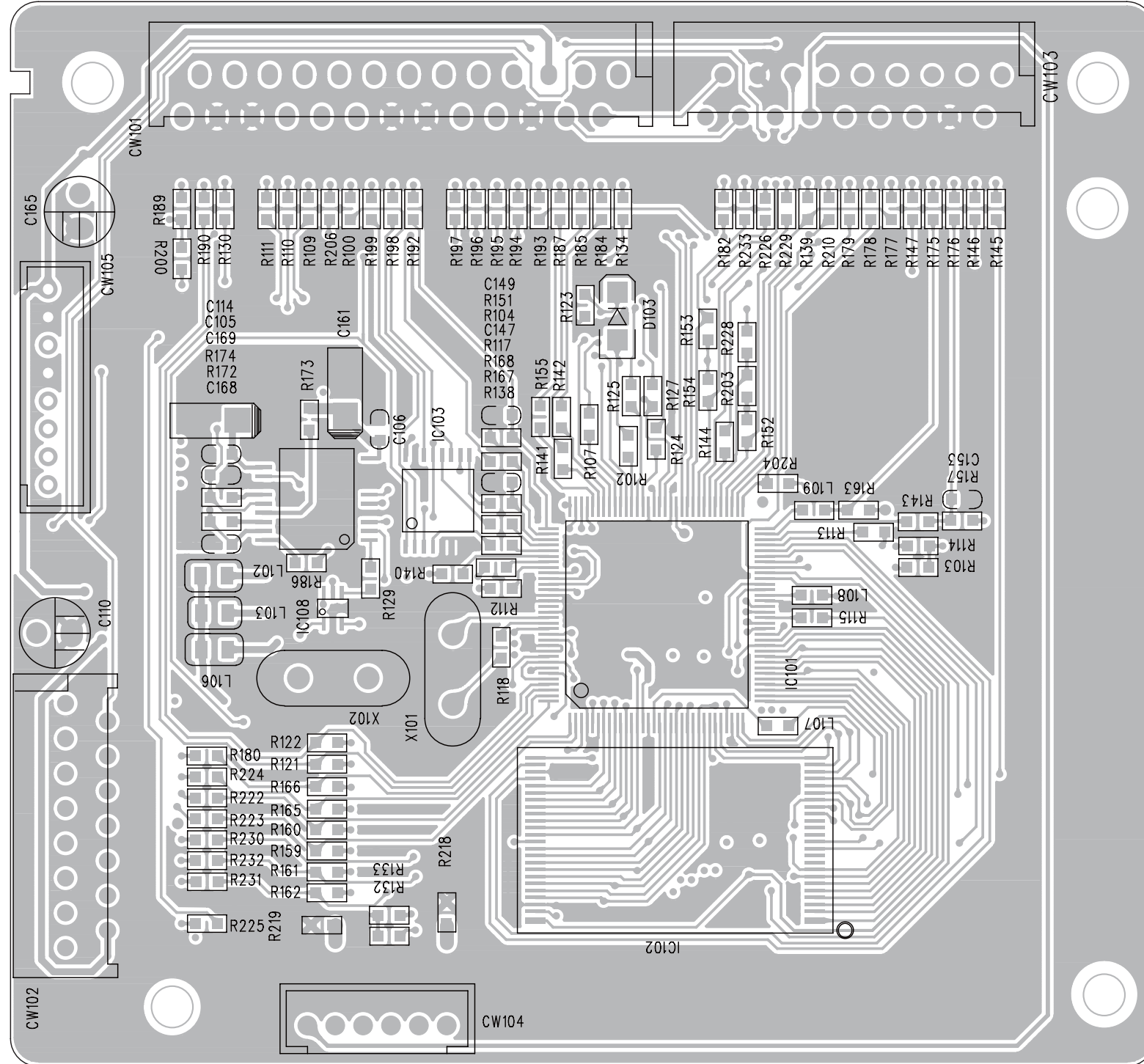

PCB LAYOUT - MCU BOARD  
BOTTOM SIDE

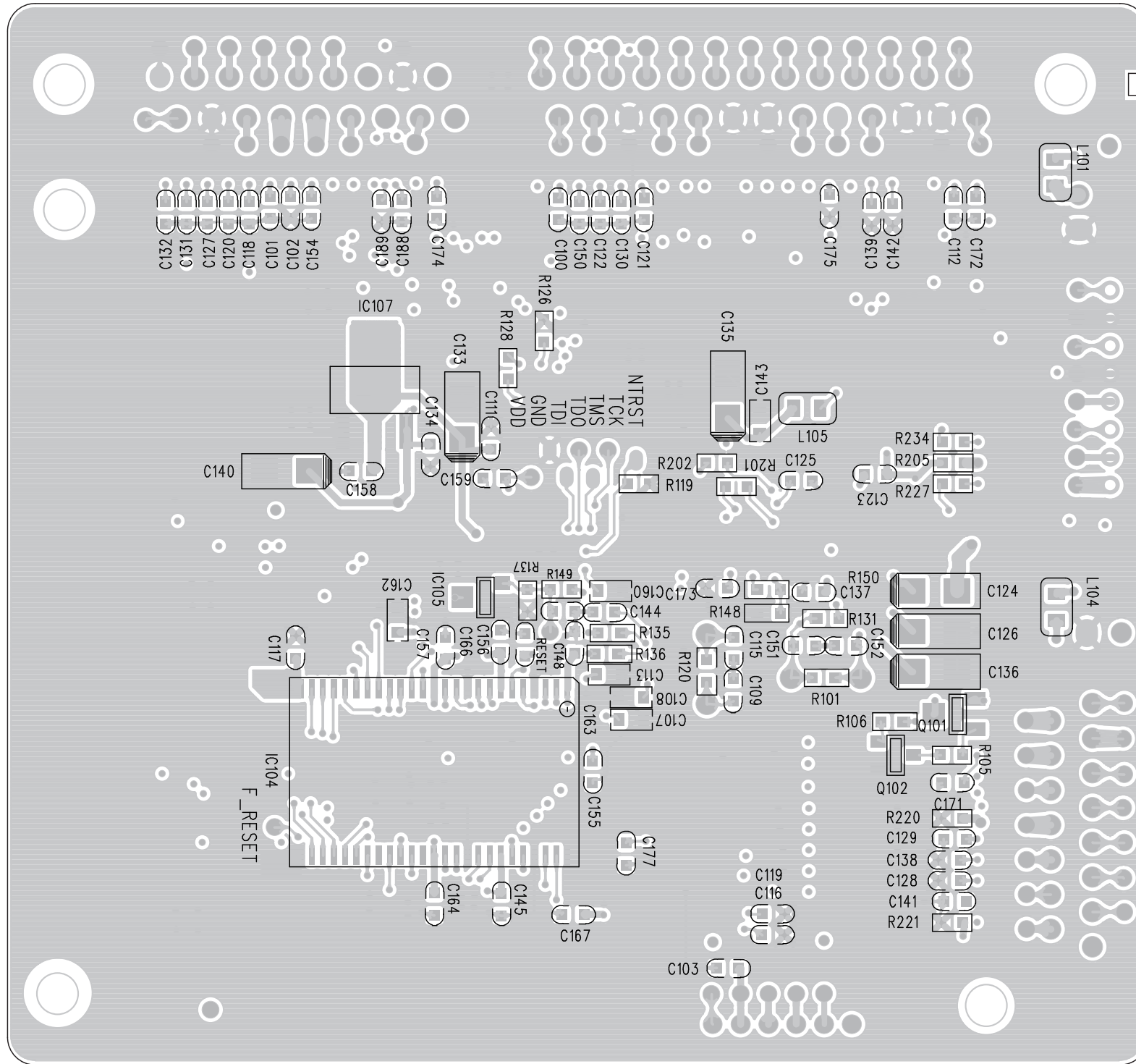

SET EXPLODED VIEW

