



DATA IMAGE CORPORATION

TFT Module Specification Preliminary

ITEM NO.: FX050053DSSWAGT1

Table of Contents

1. COVER & CONTENTS	1
2. RECORD OF REVISION	2
3. APPLICATION.....	3
4. GENERAL SPECIFICATIONS	3
5. ABSOLUTE MAXIMUM RATINGS	3
6. ELECTRICAL CHARACTERISTICS	3
7. BLOCK DIAGRAM	4
8. PIN CONNECTIONS	5
9. INTERFACE SPECIFICATIONS	8
10. OPTICAL CHARACTERISTIC	12
11. TOUCH PANEL CHARACTERISTICS.....	15
12. QUALITY ASSURANCE	16
13. LCM PRODUCT LABEL DEFINE	17
14. PRECAUTIONS IN USE LCM	19
15. OUTLINE DRAWING	20
16. PACKAGE INFORMATION.....	21

Customer Companies	R&D Dept.	Q.C. Dept.	Eng. Dept.	Prod. Dept.
	JACK	JOE	GARY	KEN
Approved by	Version:	Issued Date:	Sheet Code:	Total Pages:
	2	01/JUL/11'		21

2. RECORD OF REVISION

Rev	Date	Item	Page	Comment
1	16/MAY/11'			Initial preliminary
2	01/JUL/11'	7 9 10 11 12 15	4 8 12 15 16 20	1. Modify BLOCK DIAGRAM. 2. Modify INTERFACE SPECIFICATIONS. 3. Modify OPTICAL CHARACTERISTIC. 4. Modify TOUCH PANEL CHARACTERISTICS 5. Modify QUALITY ASSURANCE 6. Modify OUTLINE DRAWING From Rve.2 To Rev.3

3. APPLICATION

Digital equipments which need color display, such as P.O.S, medical equipments and industrial equipments.

4. GENERAL SPECIFICATIONS

Parameter	Specifications	Unit
Display resolution	(800X R.G.B) (W) x480(H)	dot
Active area	108(W) x 64.8(H)	mm
Screen size	5.0(Diagonal)	inch
Dot pitch	0.045(W) x 0.135(H)	mm
Color configuration	R.G.B. Stripe	
Overall dimension	118.1(W) x 77(H) x 4.26 (T)	mm
Weight	TBD	g
Surface treatment	Anti-Glare & Hard Coating	
View Angle direction(Gray inversion)	6 o'clock	
Our components and processes are compliant to RoHS standard		

5. ABSOLUTE MAXIMUM RATINGS

Parameter	Symbol	MIN.	MAX.	Unit	Remark
Power supply voltage	V _{cc}	-0.3	5.0	V	
Logic input voltage	V _I	-0.3	5.0	V	
Operating temperature	Top	-10	+60	°C	Ambient temperature
Storage temperature	T _{st}	-20	+70	°C	Ambient temperature

6. ELECTRICAL CHARACTERISTICS

GND=0V,CLK=33.26MHz,Ta=25°C

Parameter	Symbol	MIN.	Typ.	MAX.	Unit	Remark
Power Supply voltage for LCD	V _{CC}	+3.0	+3.3	+3.6	V	V _{CC} =3.3V
Power Supply Current for LCD	I _{CC}		95	125	mA	
Power Supply voltage for LCD	AVDD	4.8	5.0	5.2		
Power Supply voltage for LED	V _{LED}	--	26.5	--	V	
Power Supply Current for LED	I _{LED}	--	26	40	mA	
"H" level logical input voltage	V _{IH}	0.7V _{cc}	--	V _{cc}	V	
"L" level logical input voltage	V _{IL}	0	--	0.3V _{cc}	V	
LED dice life time		--	T.B.D	--	Hr	Note 1

Note 1: The "LED dice life time" is defined as the module brightness decrease to 50% original brightness that the ambient temperature is 25

7. BLOCK DIAGRAM

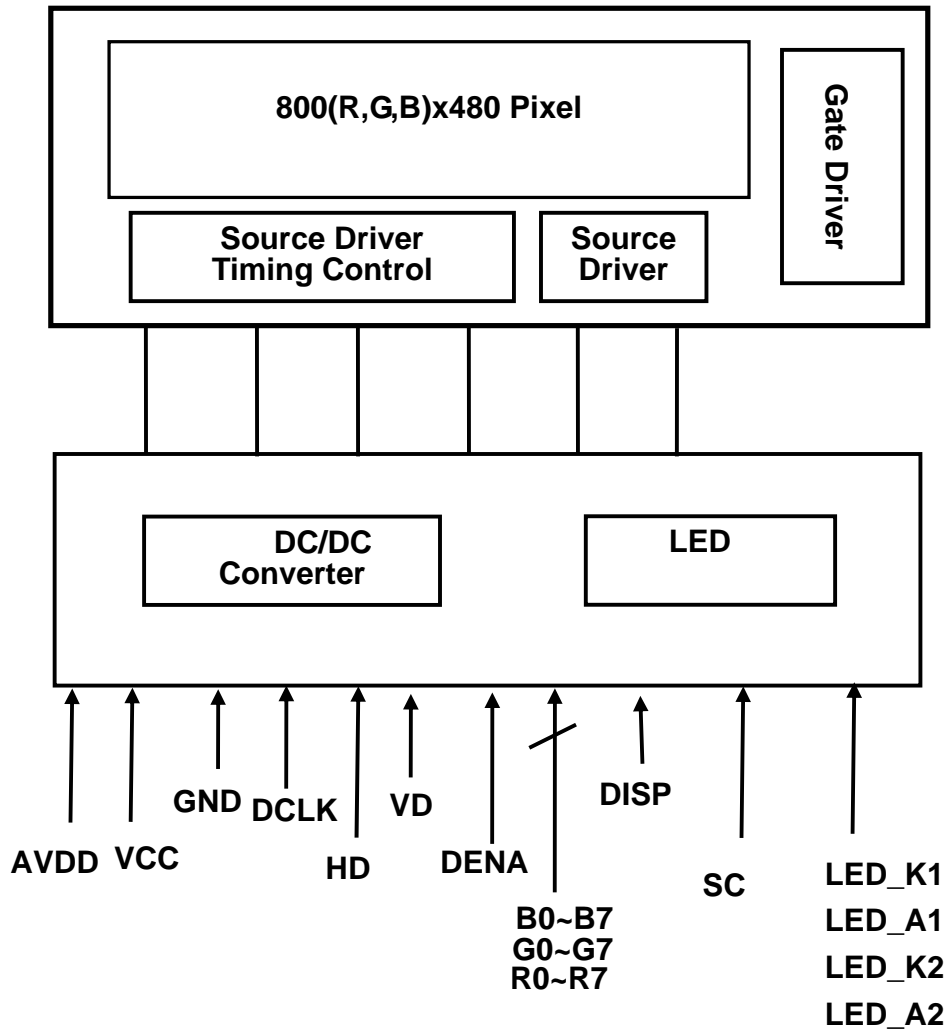

8. PIN CONNECTIONS

No	Symbol	I/O	Description
1	GND	I	Ground.
2	GND	I	Ground.
3	VCC	I	Digital power. 3V – 3.6V.
4	VCC	I	Digital power. 3V – 3.6V.
5	R0	I	Red data signal(LSB)
6	R1	I	Red data signal
7	R2	I	Red data signal
8	R3	I	Red data signal
9	R4	I	Red data signal
10	R5	I	Red data signal
11	R6	I	Red data signal
12	R7	I	Red data signal(MSB)
13	G0	I	Green data signal(LSB)
14	G1	I	Green data signal
15	G2	I	Green data signal
16	G3	I	Green data signal
17	G4	I	Green data signal
18	G5	I	Green data signal
19	G6	I	Green data signal
20	G7	I	Green data signal(MSB)
21	B0	I	Blue data signal(LSB)
22	B1	I	Blue data signal
23	B2	I	Blue data signal
24	B3	I	Blue data signal
25	B4	I	Blue data signal
26	B5	I	Blue data signal
27	B6	I	Blue data signal
28	B7	I	Blue data signal(MSB)
29	GND	I	Ground
30	DCLK (CLK)	I	Clock signal for sampling catch data signal
31	DISP	I	Display on/off(High:on,Low:off)

32	HD(HS)	I	Horizontal sync signal
33	VD(VS)	I	Vertical sync signal
34	DENA (DEN)	I	Data enable signal(to settle the viewing area)
35	AVDD	I	5.0V Analog Power Supply
36	AVDD	I	5.0V Analog Power Supply
37	NC	I	No connection
38	NC	I	No connection
39	SC	I	Scan direction control(Low=Reverse, High=Normal)
40	GND	I	Ground
41	GND	I	Ground
42	LED_K1	I	LED cathode
43	LED_A1	I	LED anode
44	LED_K2	I	LED cathode
45	LED_A2	I	LED anode

Display position and scan direction

D(X,Y) shows the data number of input signal for LCD panel signal processing PCB.

SC: High

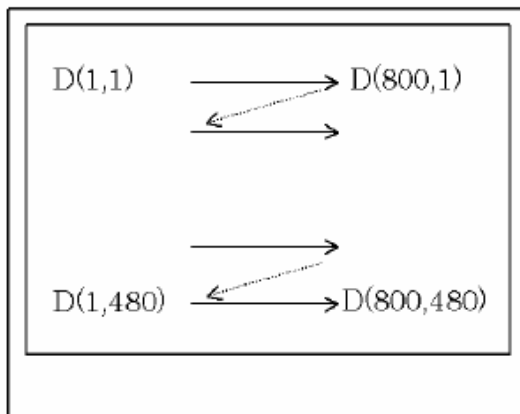

SC: Low

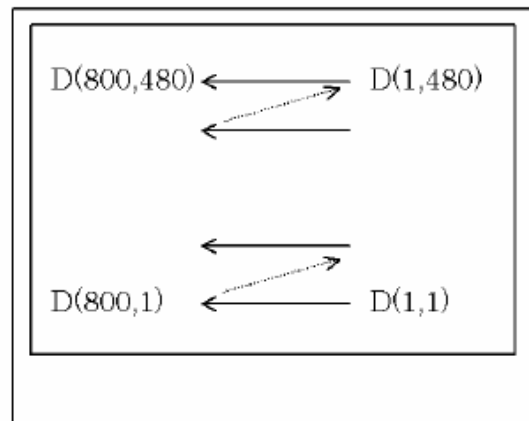

8.1 Power Signal Sequence

Remarks:

*1) Power

Signal

sequence:

$t1 \leq 10\text{ms}$:

$1\text{sec} \leq t5$

$50\text{ms} \leq t2$:

$200\text{ms} \leq t6$

$0 < t3 \leq 50\text{ms}$:

$200\text{ms} \leq t7$

$0 < t4 \leq 10\text{ms}$

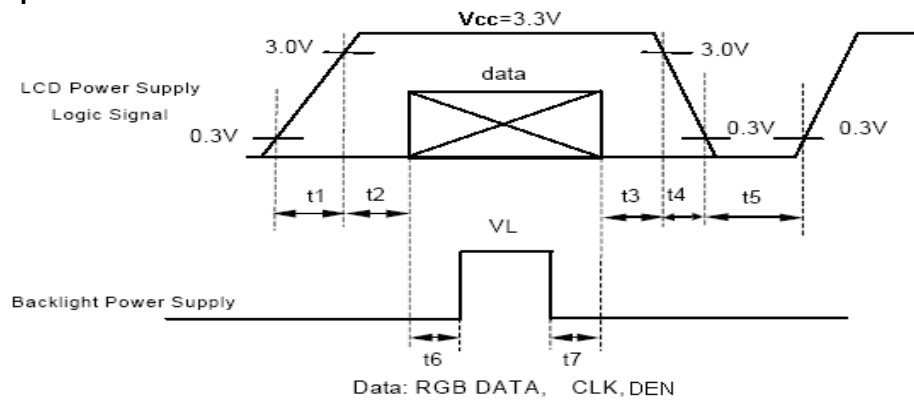

*2) VCC-dip condition:

(1) $2.7\text{V} \leq V_{CC} < 3.0\text{V}$, $t_d \leq 10\text{ms}$

(2) $V_{CC} > 3.0\text{V}$, VCC-dip condition should be the same with VCC-turn-on condition.

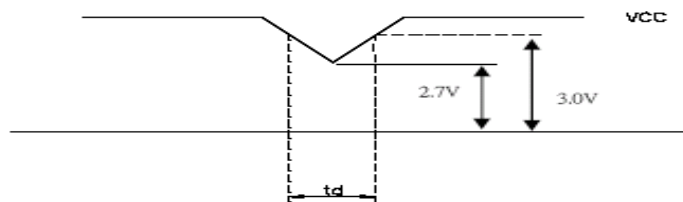

9. INTERFACE SPECIFICATIONS

9.1 Input Signal Characteristics

9.1.1 AC Electrical Characteristics

Parameter	Symbol	MIN.	TYP.	MAX.	Unit
HS setup time	T_{hst}	6	-	-	ns
HS hold time	T_{nhd}	6	-	-	ns
VS setup time	T_{vst}	6	-	-	ns
VS hold time	T_{vhd}	6	-	-	ns
Data setup time	T_{dsu}	6	-	-	ns
Data hold time	T_{dhd}	6	-	-	ns
DEN setup time	T_{esu}	6	-	-	ns
DEN setup time	T_{esu}	6	-	-	ns

9.1.2 Resolution : 800x480

● Sync mode

Parameter	Symbol	MIN.	TYP.	MAX.	Unit
CLK frequency	F_{CPH}	-	33.26	-	MHz
CLK period	T_{CPH}	-	30.06	-	ns
CLK pulse duty	T_{CWH}	40	50	60	%
HS period	T_H	-	1056	-	T_{CPH}
HS pulse width	T_{WH}	1	128	-	T_{CPH}
HS-first horizontal data time	T_{HS}	-	216	-	T_{CPH}
HS Active Time	T_{HA}	-	800	-	T_{CPH}
VS period	T_V	-	525	-	T_H
VS pulse width	T_{WV}	1	2	-	T_H
VS-DEN time	T_{VS}	-	35	-	T_H
VS Active Time	T_{VA}	-	480	-	T_H

● DE mode

Parameter	Symbol	MIN.	TYP.	MAX.	Unit
CLK frequency	F_{CPH}	-	33.26	-	MHz
CLK period	T_{CPH}	-	30.06	-	ns
CLK pulse duty	T_{CWH}	40	50	60	%
DEN period	$T_{DEH}+T_{DEL}$	1000	1056	1200	T_{CPH}
DEN pulse width	T_{DH}	-	800	-	T_{CPH}
DEN frame blanking	T_{DEB}	10	45	110	$T_{DEH}+T_{DEL}$
DEN frame width	T_{DE}	-	480	-	$T_{DEH}+T_{DEL}$

(i) $T_{VS} + T_{VA} < T_H$

9.2 Timing Controller Timing Chart
9.2.1 Clock and Data Input Waveforms

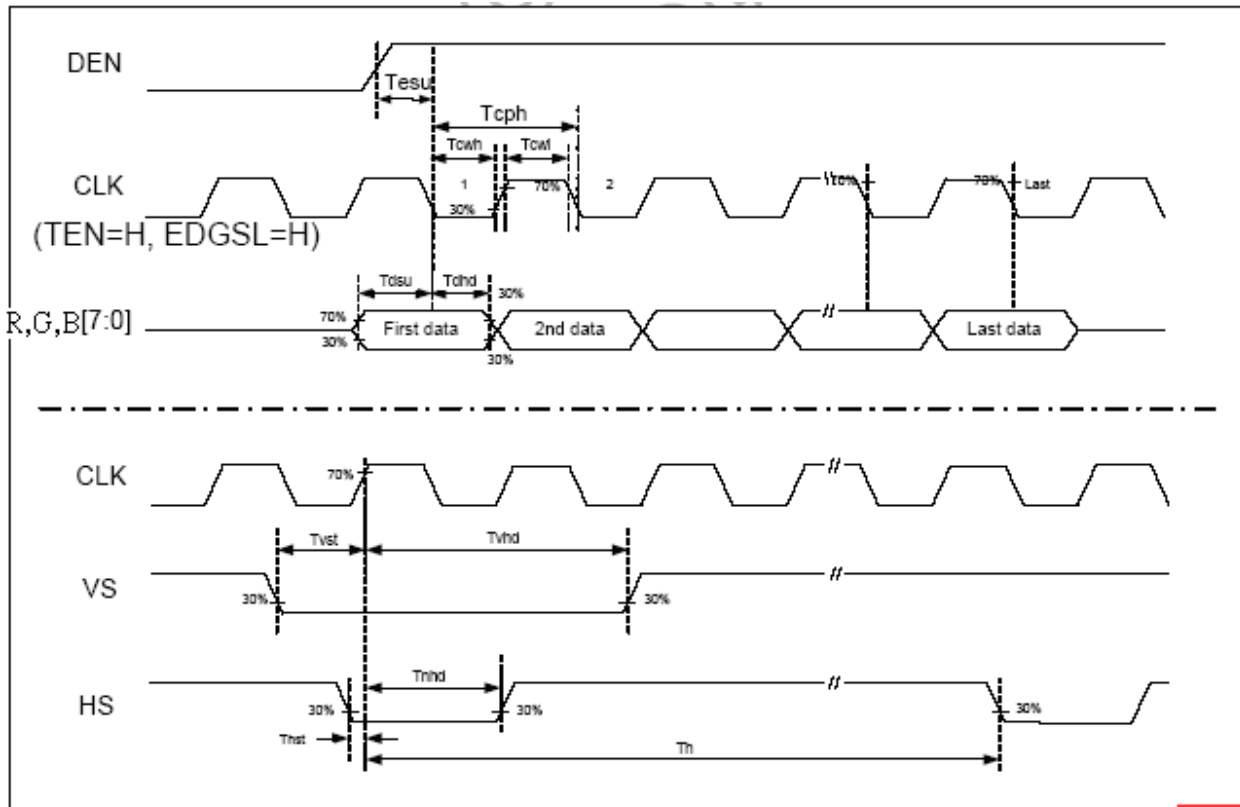
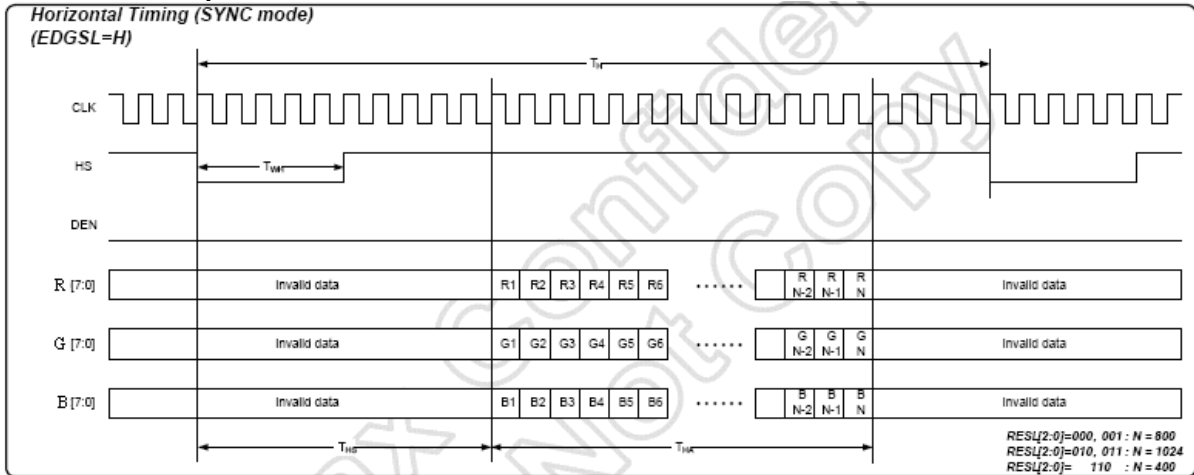
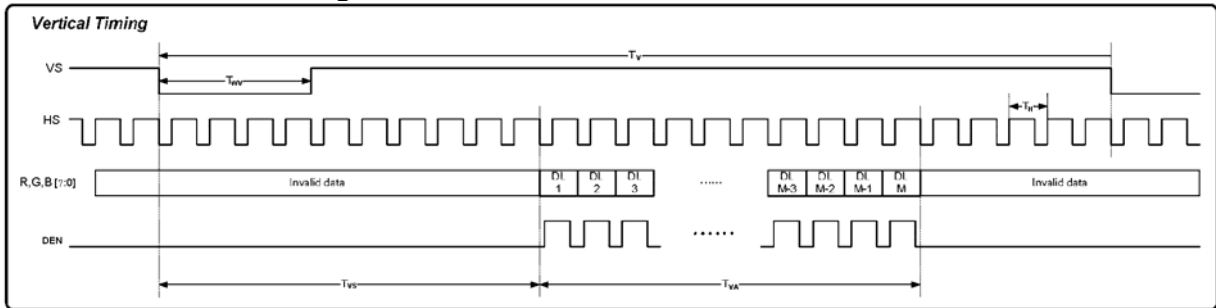
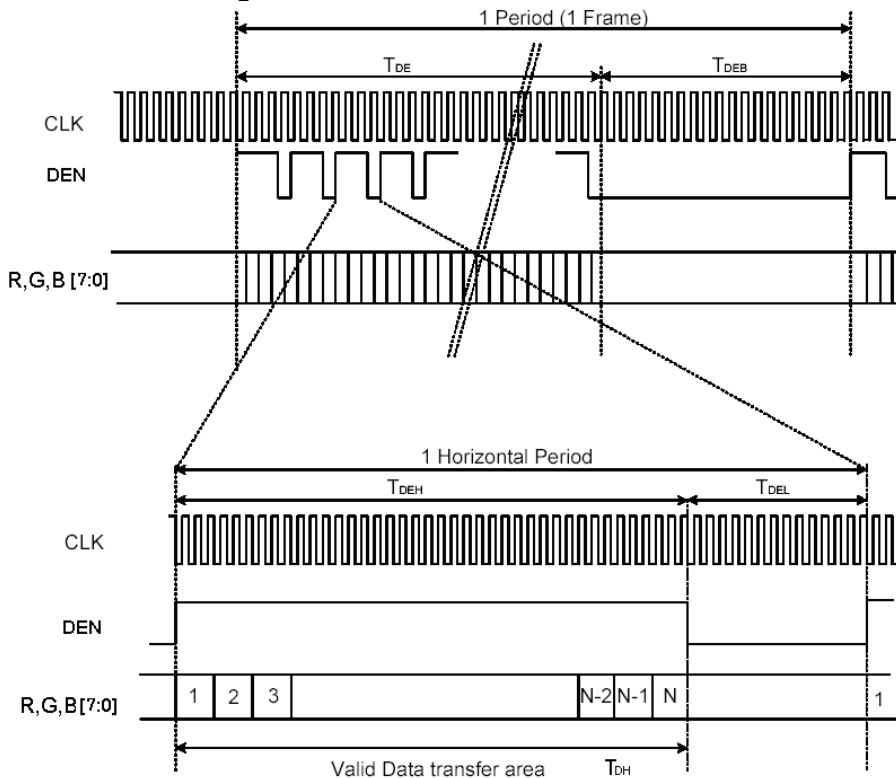

Figure 1 Clock and Data input waveforms.

9.2.2 Data input format

Figure 2 SYNC Mode Vertical Data Format

Figure 3 SYNC Mode Vertical Data Format

Figure 4 DE Mode Data Format

9.3 Color Data Input Assignment

COLOR	INPUT DATA	R DATA								G DATA								B DATA							
		R7	R6	R5	R4	R3	R2	R1	R0	R7	R6	R5	R4	R3	R2	R1	R0	R7	R6	R5	R4	R3	R2	R1	R0
		MSB							LSB	MSB							LSB	MSB							LSB
BASIC COLOR	BLACK	0	0	0	0	0	0	0	0	0	0	0	0	0	0	0	0	0	0	0	0	0	0	0	0
	RED(255)	1	1	1	1	1	1	1	1	0	0	0	0	0	0	0	0	0	0	0	0	0	0	0	0
	GREEN(255)	0	0	0	0	0	0	0	0	1	1	1	1	1	1	1	1	0	0	0	0	0	0	0	0
	BLUE(255)	0	0	0	0	0	0	0	0	0	0	0	0	0	0	0	0	1	1	1	1	1	1	1	1
	CYAN	0	0	0	0	0	0	0	0	1	1	1	1	1	1	1	1	1	1	1	1	1	1	1	1
	MAGENTA	1	1	1	1	1	1	1	1	0	0	0	0	0	0	0	0	1	1	1	1	1	1	1	1
	YELLOW	1	1	1	1	1	1	1	1	1	1	1	1	1	1	1	1	0	0	0	0	0	0	0	0
	WHITE	1	1	1	1	1	1	1	1	1	1	1	1	1	1	1	1	1	1	1	1	1	1	1	1
RED	RED(0)	0	0	0	0	0	0	0	0	0	0	0	0	0	0	0	0	0	0	0	0	0	0	0	
	RED(1)	0	0	0	0	0	0	0	1	0	0	0	0	0	0	0	0	0	0	0	0	0	0	0	
	RED(2)	0	0	0	0	0	0	1	0	0	0	0	0	0	0	0	0	0	0	0	0	0	0	0	
	RED(254)	1	1	1	1	1	1	1	0	0	0	0	0	0	0	0	0	0	0	0	0	0	0	0	
	RED(255)	1	1	1	1	1	1	1	1	0	0	0	0	0	0	0	0	0	0	0	0	0	0	0	0
GREEN	GREEN(0)	0	0	0	0	0	0	0	0	0	0	0	0	0	0	0	0	0	0	0	0	0	0	0	
	GREEN(1)	0	0	0	0	0	0	0	0	0	0	0	0	0	0	0	1	0	0	0	0	0	0	0	
	GREEN(2)	0	0	0	0	0	0	0	0	0	0	0	0	0	0	1	0	0	0	0	0	0	0	0	
	GREEN(254)	0	0	0	0	0	0	0	0	1	1	1	1	1	1	1	0	0	0	0	0	0	0	0	
	GREEN(255)	0	0	0	0	0	0	0	0	1	1	1	1	1	1	1	0	0	0	0	0	0	0	0	
BLUE	BLUE (0)	0	0	0	0	0	0	0	0	0	0	0	0	0	0	0	0	0	0	0	0	0	0	0	
	BLUE (1)	0	0	0	0	0	0	0	0	0	0	0	0	0	0	0	0	0	0	0	0	0	0	1	
	BLUE (2)	0	0	0	0	0	0	0	0	0	0	0	0	0	0	0	0	0	0	0	0	0	1	0	
	BLUE (254)	0	0	0	0	0	0	0	0	0	0	0	0	0	0	0	0	1	1	1	1	1	1	0	
	BLUE (255)	0	0	0	0	0	0	0	0	0	0	0	0	0	0	0	0	1	1	1	1	1	1	1	

[NOTE] :

- 1) Definition of Gray level : Color(n) : n to show the Gray level · n is the more high and the light more bright.
- 2) Data:1-High, 0-Low.

Correspondence between Data and Display Position

	S0001	S0002	S0003	S0004	S0005	S0006	S0007	S0008	-----	S2399	S2400
C001	R001	G001	B001	R002	G002	B002	R003	G003		G800	B800
⋮											
C480	R001	G001	B001	R002	G002	B002	R003	G003		G800	B800

10. OPTICAL CHARACTERISTIC

Parameter	Symbol	Condition	MIN.	TYP.	MAX.	Unit	Remarks	
Viewing Angle	Horizontal	θ_{x+}	60	70	--	deg	Note 1,4	
		θ_{x-}	60	70	--			
	Vertical	θ_{y+}	40	50	--			
		θ_{y-}	60	70	--			
Contrast Ratio	CR	at optimized viewing angle	300	400			Note 1,3	
Response time	Rise	Tr	-	15	30	ms	Note 1,6	
	Fall	Tf	-	35	50	ms		
Uniformity		B-uni	$\theta_{x=\theta y}=0^{\circ}$	70	80	--	%	Note1,5
Center Brightness	L	$\theta_{x=\theta y}=0^{\circ}$	320	400	--	cd/m ²	Note 1,2,9	
Chromaticity	x_W	Center $\theta_{x=\theta y}=0^{\circ}$	0.27	0.32	0.37		Note 1,7	
	y_W		0.30	0.35	0.40			
	x_R		0.5523	0.6023	0.6523			
	y_R		0.3159	0.3659	0.4159			
	x_G		0.3004	0.3504	0.4004			
	y_G		0.5302	0.5802	0.6302			
	x_B		0.1008	0.1508	0.2008			
	y_B		0.0852	0.1352	0.1852			
Image sticking	tis	2 hours			2	Sec	Note 8	

The following optical specifications shall be measured in a darkroom or equivalent state (ambient luminance ≤ 1 lux, and at room temperature). The operation temperature is $25^{\circ}\text{C} \pm 2^{\circ}\text{C}$. The LED current ILED=26mA. The measurement method is shown in Note1.

Note1: The method of optical measurement:

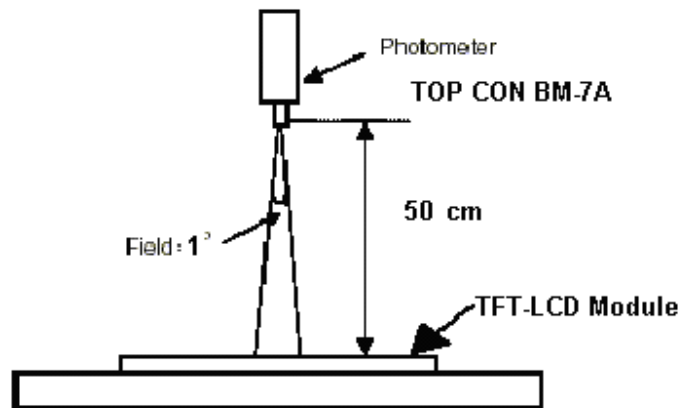

Note2: Measured at the center area of the panel and at the viewing angle of the $\theta_x = \theta_y = 0^\circ$

Note3: Definition of Contrast Ratio (CR):

$$CR = \frac{\text{Luminance with all pixels in white state}}{\text{Luminance with all pixels in Black state}}$$

Note4: Definition of Viewing Angle

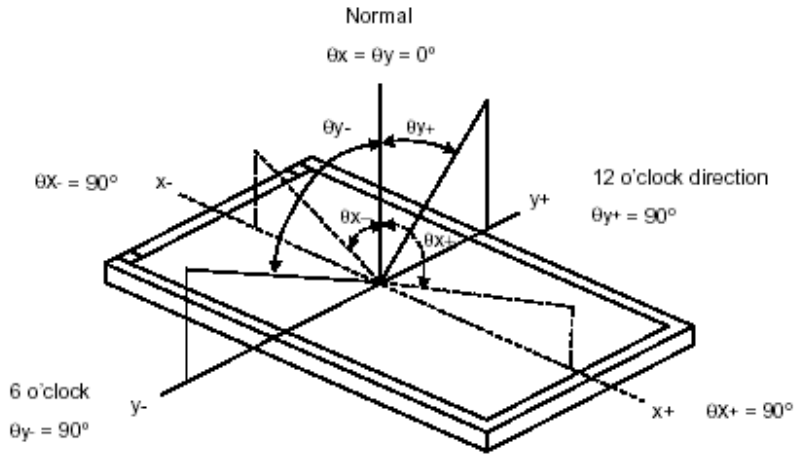

Note 5: Definition of Brightness Uniformity (B-uni):

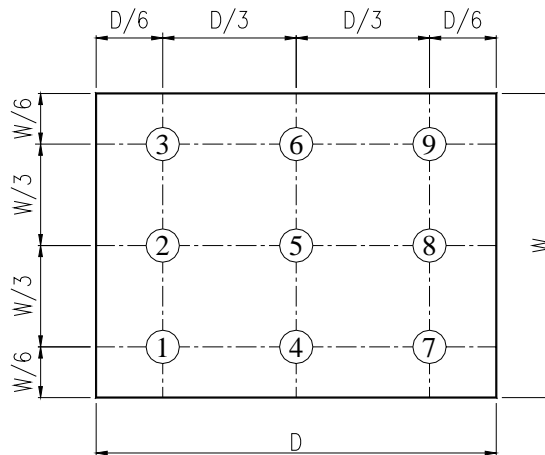

$$B\text{-uni} = \frac{\text{Minimum luminance of 9 points}}{\text{Maximum luminance of 9 points}} \quad (\text{Note 5}).$$

Note6: Definition of Response Time:

The Response Time is set initially by defining the "Rising Time (T_r)" and the "Falling Time (T_f)" respectively. T_r and T_f are defined as following figure.

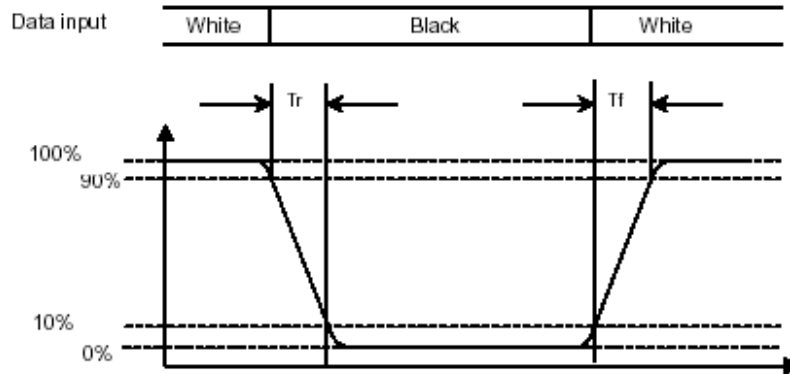

Note 7: Definition of Chromaticity:

The color coordinates (x_w, y_w), (x_r, y_r), (x_g, y_g), and (x_b, y_b) are obtained with all pixels in the viewing field at white, red, green, and blue states, respectively.

Note 8: Definition of Image sticking (tis):

Continuously display the test pattern shown in the figure below for 2 hours. Then display a completely white screen. The previous image shall not persist more than 2 sec at 25 °C

Image sticking pattern

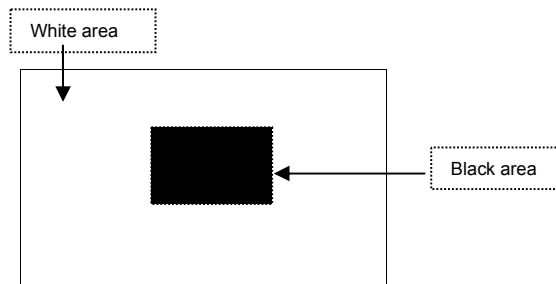

Note 9: the relationship between power consumption and brightness of the table <Just reference>

Backlight current	Power consumption	Brightness	Brightness after LCD glass	Expecting Brightness after LCD glass & TP
13mA	700mW	4600	450	340
15mA	817mW	4800	470	360
20mA	1123mW	6300	610	450

11. TOUCH PANEL CHARACTERISTICS

1. Input Method and Activation Force

Input Method	Average Activation Force
1.6mm dia .Silicon "finger"	T.B.D

2. Typical Optical Characteristics

ITEM	Parameter
Visible Light Transmission	75% (Typ)
Haze	T.B.D (Typ)

3. Electrical Specification

ITEM	Parameter	
Operating Voltage	T.B.D	
Contact current	According to individual design	
Circuit close resistance	X	T.B.DΩ
	Y	T.B.DΩ
Circuit open resistance	T.B.D	
Contact bounce	20ms	
Linear Test	1.5%	

4. Linearity

ITEM	Parameter	
Linear Test Specification Direction	X	1.5%
	Y	1.5%

5. Specification

ITEM	Parameter
Operating Temperature	-10°C~+60°C
Storage Temperature	-20°C~+70°C
Surface Treatment	Anti-Newton ring

6. Durability test:

6.1 Touch panel is hit 10 millions times with a silicone rubber of R8 finger, hitting rate is by T.B.D g at 2 times per second. The measurement must satisfy the following:

- Circuit close resistance: x T.B.DΩ ;
y T.B.DΩ.
- Circuit open resistance: >20MΩ at DC 25V
- Contact bounce: 20ms
- Linearity test: 3%

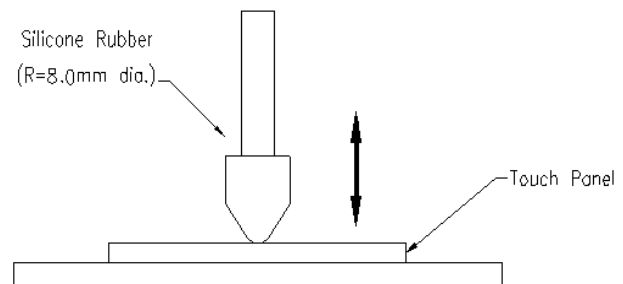

6.2 Stylus writing

Touch panel is drawn by R0.8 Darling stylus pen, at 200g forces, repeat one inch by 100k times. The measurement must satisfy the following:

- Circuit close resistance: x T.B.DΩ ;
y T.B.DΩ
- Circuit open resistance: >20MΩ at DC 25V
- Contact bounce: 20ms
- Linearity test: 3%

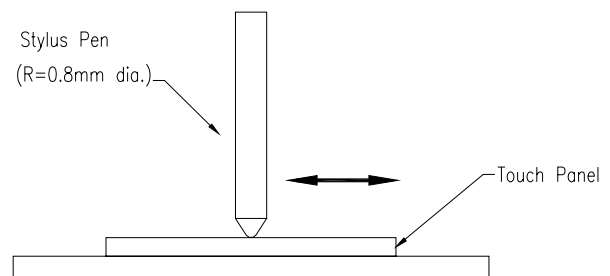

12. QUALITY ASSURANCE

12.1 Test Condition

12.1.1 Temperature and Humidity (Ambient Temperature)

Temperature : $25 \pm 5^{\circ}\text{C}$

Humidity : $65 \pm 5\%$

12.1.2 Operation

Unless specified otherwise, test will be conducted under function state.

12.1.3 Container

Unless specified otherwise, vibration test will be conducted to the product itself without putting it in a container.

12.1.4 Test Frequency

In case of related to deterioration such as shock test. It will be conducted only once.

12.1.5 Test Method

No.	Reliability Test Item & Level	Test Level
1	High Temperature Storage Test	T=70°C,240hrs
2	Low Temperature Storage Test	T=-20°C,240hrs
3	High Temperature Operation Test	T=60°C,240hrs
4	Low Temperature Operation Test	T=-10°C,240hrs
5	High Temperature and High Humidity Operation Test	T=40°C,90% RH,240hrs
6	Thermal Cycling Test (No operation)	-20°C → +25°C → +70°C,200 Cycles 30 min 5min 30 min
7	Vibration Test (No operation)	Frequency:0 ~ 55 Hz Amplitude:1.5 mm Sweep Time:11min Test Period:6 Cycles for each Direction of X,Y,Z
8	Electrostatic Discharge Test (No operation)	150pF,330Ω Air:± 15KV;Contact: ±8KV 10 times/point;4 points/panel face

13. LCM PRODUCT LABEL DEFINE

Product Label style:

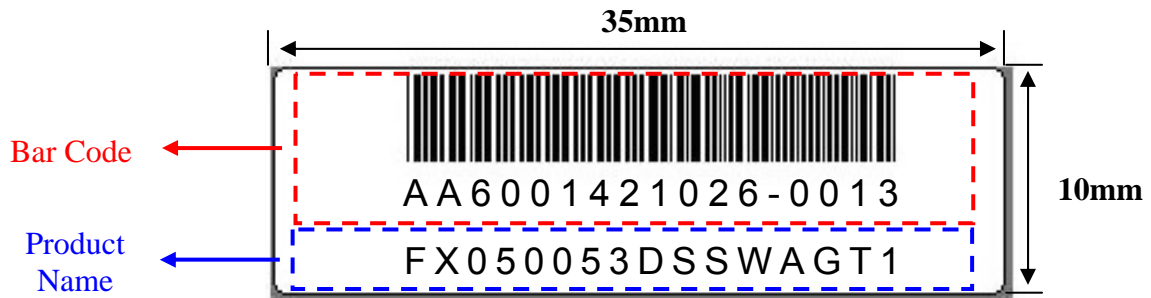

BarCode Define:

A A 6 0014 2 10 26-0013

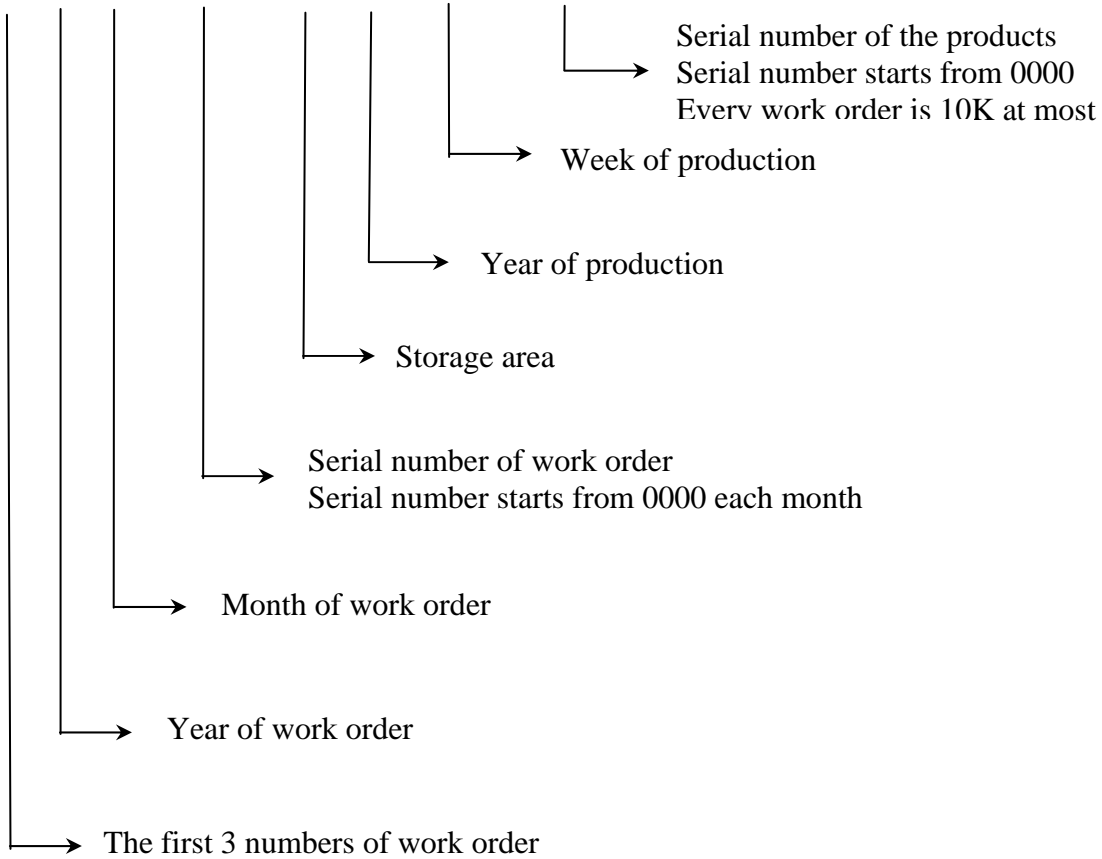

14. PRECAUTION FOR USING LCM

1. LIQUID CRYSTAL DISPLAY (LCD)

LCD is made up of glass, organic sealant, organic fluid, and polymer based polarizers. The following precautions should be taken when handling,

- (1). Keep the temperature within range of use and storage. Excessive temperature and humidity could cause polarization degradation, polarizer peel off or bubble.
- (2). Do not contact the exposed polarizers with anything harder than an HB pencil lead. To clean dust off the display surface, wipe gently with cotton, chamois or other soft material soaked in petroleum benzine.
- (3). Wipe off saliva or water drops immediately. Contact with water over a long period of time may cause polarizer deformation or color fading, while an active LCD with water condensation on its surface will cause corrosion of ITO electrodes.
- (4). Glass can be easily chipped or cracked from rough handling, especially at corners and edges.
- (5). Do not drive LCD with DC voltage.

2. Liquid Crystal Display Modules

2.1 Mechanical Considerations

LCM are assembled and adjusted with a high degree of precision. Avoid excessive shocks and do not make any alterations or modifications. The following should be noted.

- (1). Do not tamper in any way with the tabs on the metal frame.
- (2). Do not modify the PCB by drilling extra holes, changing its outline, moving its components or modifying its pattern.
- (3). Do not touch the elastomer connector, especially insert a backlight panel (for example, EL).
- (4). When mounting a LCM make sure that the PCB is not under any stress such as bending or twisting. Elastomer contacts are very delicate and missing pixels could result from slight dislocation of any of the elements.
- (5). Avoid pressing on the metal bezel, otherwise the elastomer connector could be deformed and lose contact, resulting in missing pixels.

2.2. Static Electricity

LCM contains CMOS LSI's and the same precaution for such devices should apply, namely

- (1). The operator should be grounded whenever he/she comes into contact with the module. Never touch any of the conductive parts such as the LSI pads, the copper leads on the PCB and the interface terminals with any parts of the human body.
- (2). The modules should be kept in antistatic bags or other containers resistant to static for storage.
- (3). Only properly grounded soldering irons should be used.
- (4). If an electric screwdriver is used, it should be well grounded and shielded from commutator sparks.

(5) The normal static prevention measures should be observed for work clothes and working benches; for the latter conductive (rubber) mat is recommended.

(6). Since dry air is inductive to statics, a relative humidity of 50-60% is recommended.

2.3 Soldering

- (1). Solder only to the I/O terminals.
- (2). Use only soldering irons with proper grounding and no leakage.
- (3). Soldering temperature : $280^{\circ}\text{C} \pm 10^{\circ}\text{C}$
- (4). Soldering time: 3 to 4 sec.
- (5). Use eutectic solder with resin flux fill.
- (6). If flux is used, the LCD surface should be covered to avoid flux spatters. Flux residue should be removed afterwards.

2.4 Operation

- (1). The viewing angle can be adjusted by varying the LCD driving voltage V_0 .
- (2). Driving voltage should be kept within specified range; excess voltage shortens display life.
- (3). Response time increases with decrease in temperature.
- (4). Display may turn black or dark blue at temperatures above its operational range; this is (however not pressing on the viewing area) may cause the segments to appear "fractured".
- (5). Mechanical disturbance during operation (such as pressing on the viewing area) may cause the segments to appear "fractured".

2.5 Storage

If any fluid leaks out of a damaged glass cell, wash off any human part that comes into contact with soap and water. Never swallow the fluid. The toxicity is extremely low but caution should be exercised at all the time.

2.6 Limited Warranty

Unless otherwise agreed between DATA IMAGE and customer, DATA IMAGE will replace or repair any of its LCD and LCM which is found to be defective electrically and visually when inspected in accordance with DATA IMAGE acceptance standards, for a period on one year from date of shipment. Confirmation of such date shall be based on freight documents. The warranty liability of DATA IMAGE is limited to repair and/or replacement on the terms set forth above. DATA IMAGE will not be responsible for any subsequent or consequential events.

16. PACKAGE INFORMATION

T.B.D