

## LSOP4, DC Input, Photo Transistor Coupler

### Description

The FX101 series combine an AlGaAs infrared emitting diode as the emitter which is optically coupled to a silicon planar phototransistor detector in a plastic LSOP4 package.

With the robust coplanar double mold structure, FX101 series provide the most stable isolation feature.

### Features

- High isolation 5000 VRMS
- CTR flexibility available see order information
- DC input with transistor output
- Operating temperature range - 55 °C to 110 °C
- Copper Leadframe
- REACH Compliance
- MSL class 1
- Halogen free (Optional)
- Regulatory Approvals
  - VDE - EN60747-5-5(VDE0884-5)
  - CQC - GB4943.1, GB8898

### Applications

- Switch mode power supplies
- Programmable controllers
- Household appliances
- Office equipment

### SCHEMATIC

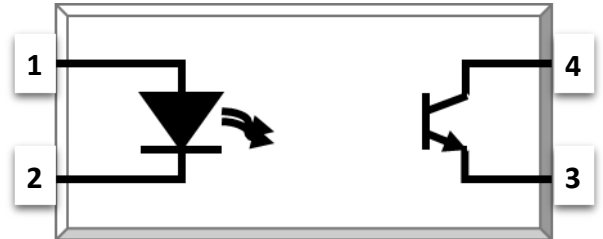

### PIN DEFINITION

1. Anode
2. Cathode
3. Emitter
4. Collector

### PACKAGE OUTLINE

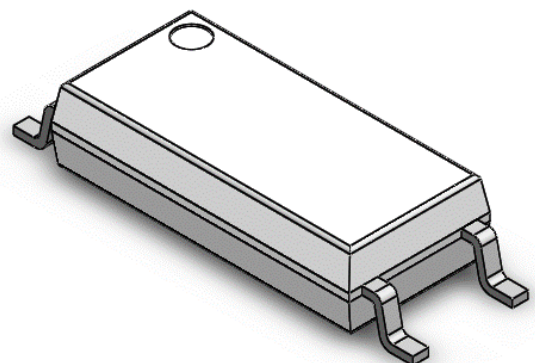



**LSOP4, DC Input, Photo Transistor Coupler**

<b>ABSOLUTE MAXIMUM RATINGS</b>				
PARAMETER	SYMBOL	VALUE	UNIT	NOTE
<b>INPUT</b>				
Forward Current	$I_F$	60	mA	
Peak Forward Current	$I_{FP}$	1	A	1
Reverse Voltage	$V_R$	6	V	
Input Power Dissipation	$P_i$	100	mW	
<b>OUTPUT</b>				
Collector - Emitter Voltage	$V_{CEO}$	80	V	
Emitter - Collector Voltage	$V_{ECO}$	7	V	
Collector Current	$I_c$	50	mA	
Output Power Dissipation	$P_o$	150	mW	
<b>COMMON</b>				
Total Power Dissipation	$P_{tot}$	250	mW	
Isolation Voltage	$V_{iso}$	5000	Vrms	2
Operating Temperature	$T_{opr}$	-55~110	°C	
Storage Temperature	$T_{stg}$	-55~125	°C	
Soldering Temperature	$T_{sol}$	260	°C	

Note 1. 100μs pulse, 100Hz frequency

Note 2. AC For 1 Minute, R.H. = 40 ~ 60%



LSOP4, DC Input, Photo Transistor Coupler

ELECTRICAL OPTICAL CHARACTERISTICS at Ta=25°C								
PARAMETER	SYMBOL	MIN.	TYP.	MAX.	UNIT	TEST CONDITION	NOTE	
INPUT								
Forward Voltage	V <sub>F</sub>	-	1.24	1.4	V	I <sub>F</sub> =10mA		
Reverse Current	I <sub>R</sub>	-	-	10	μA	V <sub>R</sub> =6V		
Input Capacitance	C <sub>in</sub>	-	30	250	pF	V=0, f=1kHz		
OUTPUT								
Collector Dark Current	I <sub>CEO</sub>	-	-	100	nA	V <sub>CE</sub> =20V, I <sub>F</sub> =0		
Collector-Emitter Breakdown Voltage	BV <sub>CEO</sub>	80	-	-	V	I <sub>C</sub> =0.1mA, I <sub>F</sub> =0		
Emitter-Collector Breakdown Voltage	BV <sub>ECO</sub>	7	-	-	V	I <sub>E</sub> =0.1mA, I <sub>F</sub> =0		
TRANSFER CHARACTERISTICS								
Current Transfer Ratio	FX1010	CTR	300	-	600	%	I <sub>F</sub> =5mA, V <sub>CE</sub> =5V	
	FX1015		50	-	150			
	FX1016		100	-	300			
	FX1017		80	-	160			
	FX1018		130	-	260			
	FX1019		200	-	400			
	FX1011		60	-	300		I <sub>F</sub> =10mA, V <sub>CE</sub> =5V	
	FX1012		63	-	125			
	FX1013		100	-	200			
	FX1014		160	-	320			
	FX1012		22	-	-			
	FX1013		34	-	-		I <sub>F</sub> =1mA, V <sub>CE</sub> =5V	
	FX1014		56	-	-			
Collector-Emitter Saturation Voltage	V <sub>CE(sat)</sub>	-	0.1	0.3	V	I <sub>F</sub> =10mA, I <sub>C</sub> =1mA		
Isolation Resistance	R <sub>ISO</sub>	10 <sup>12</sup>	10 <sup>14</sup>	-	Ω	DC500V, 40 ~ 60% R.H.		
Floating Capacitance	C <sub>IO</sub>	-	0.4	1	pF	V=0, f=1MHz		
Cut-off Frequency	F <sub>c</sub>	-	80	-	kHz	V <sub>CE</sub> =2V, I <sub>C</sub> =2mA R <sub>L</sub> =100Ω, -3dB	3	
Response Time (Rise)	T <sub>r</sub>	-	5	18	μs	V <sub>CE</sub> =2V, I <sub>C</sub> =2mA R <sub>L</sub> =100Ω	4	
Response Time (Fall)	T <sub>f</sub>	-	6	18	μs		4	

Note 3. Fig.12&13; Note 4. Fig.14

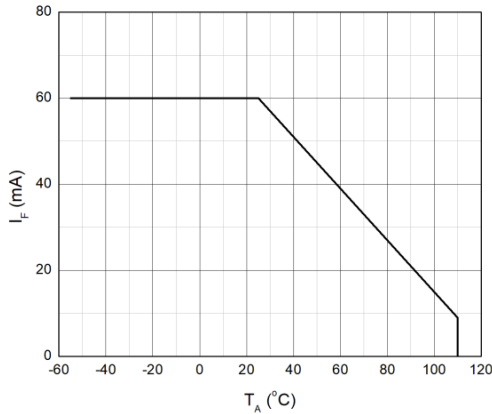
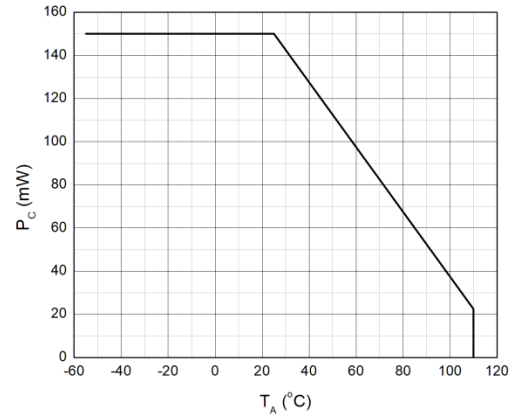
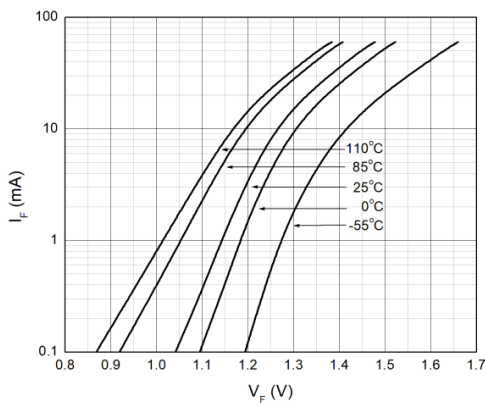
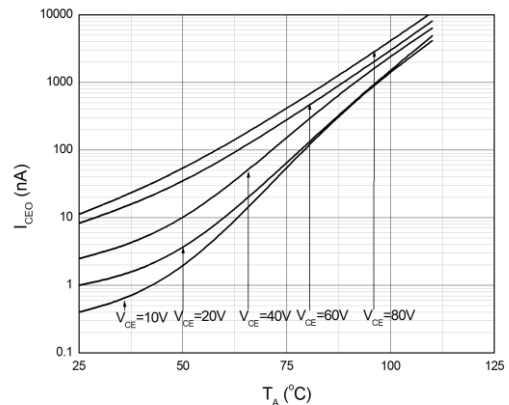
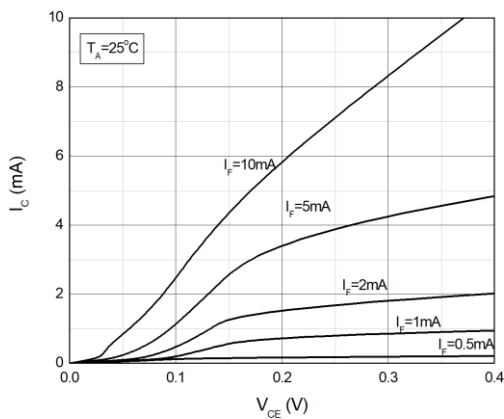
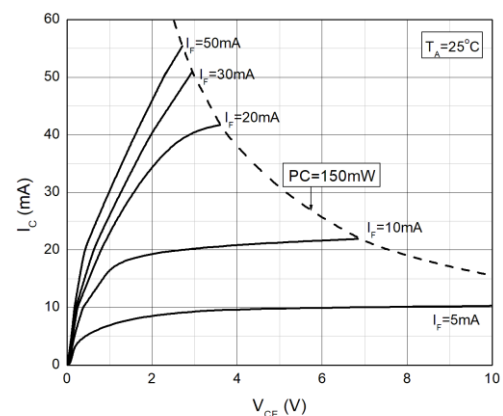
**LSOP4, DC Input, Photo Transistor Coupler**
**CHARACTERISTIC CURVES**
**Fig.1 Forward Current vs. Ambient Temperature**

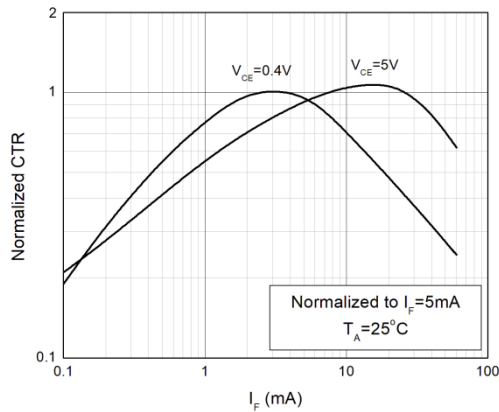
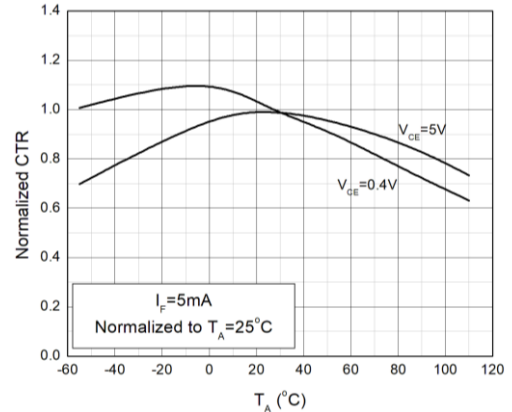
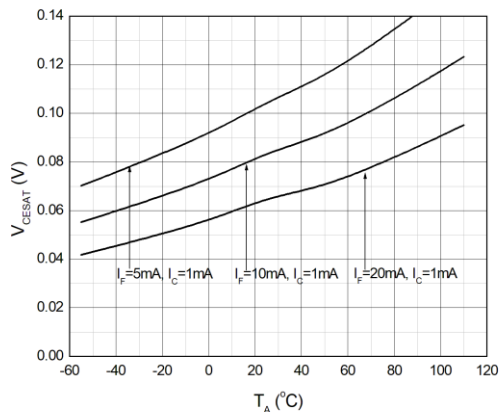
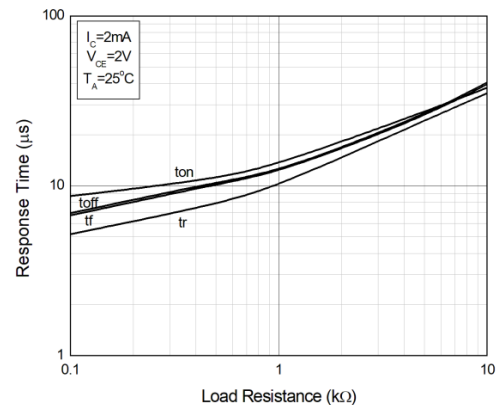
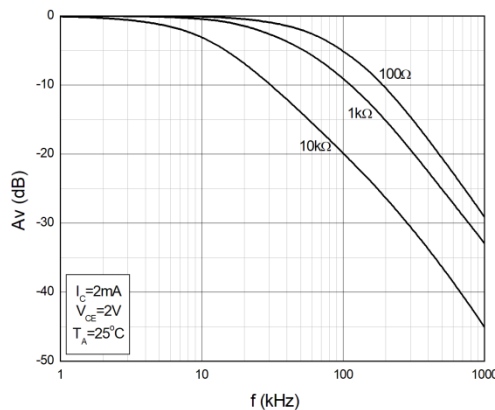
**Fig.2 Collector Power Dissipation vs. Ambient Temperature**

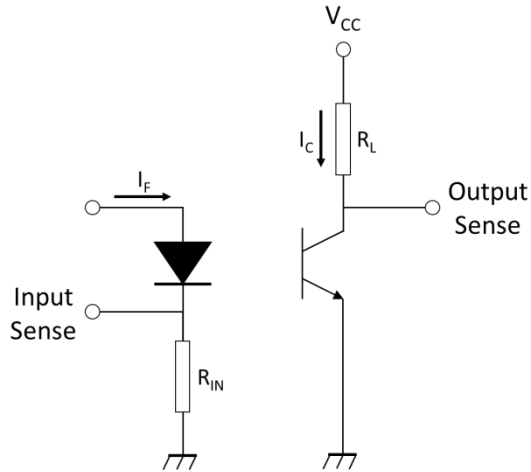
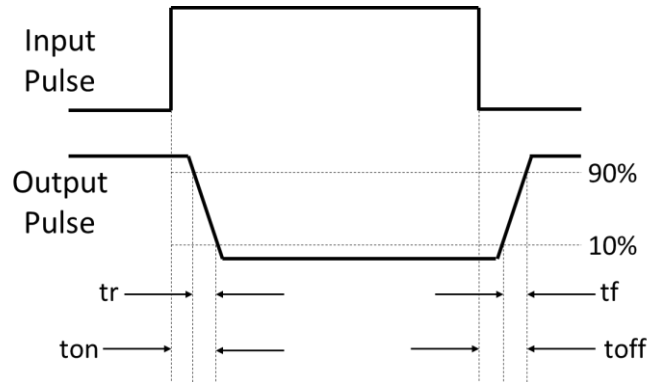
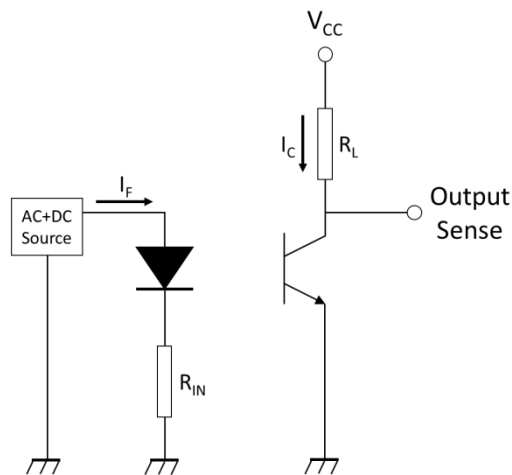
**Fig.3 Forward Current vs. Forward Voltage**

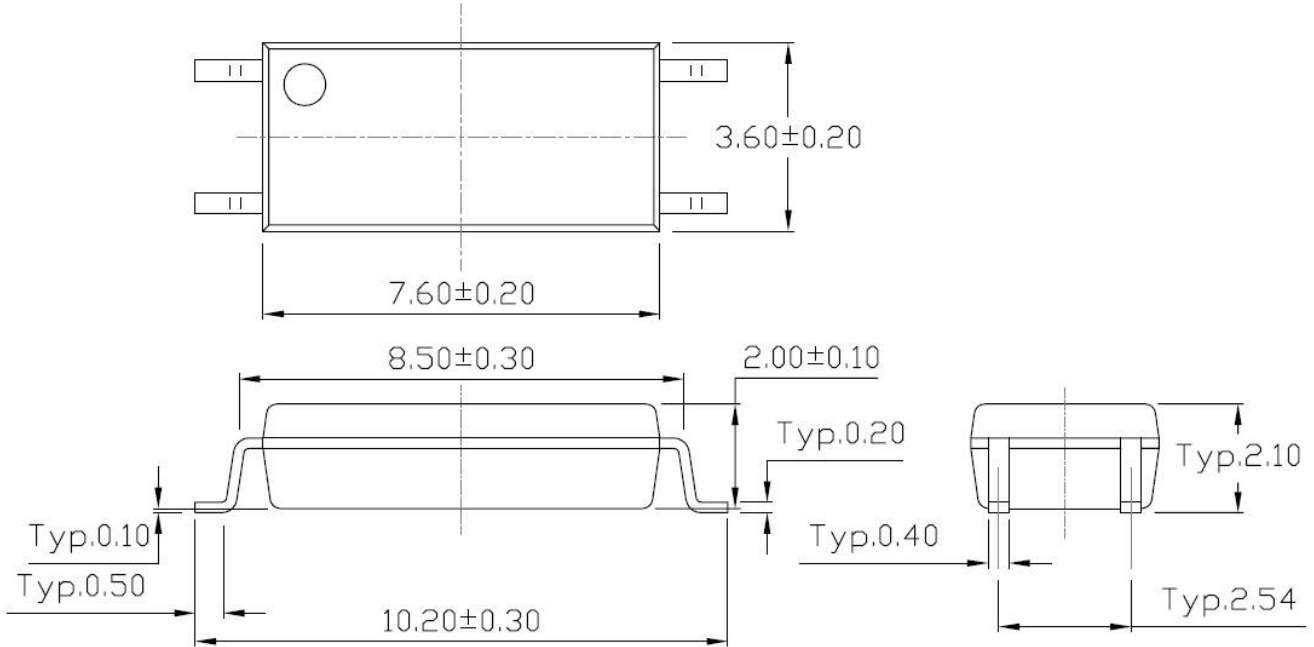
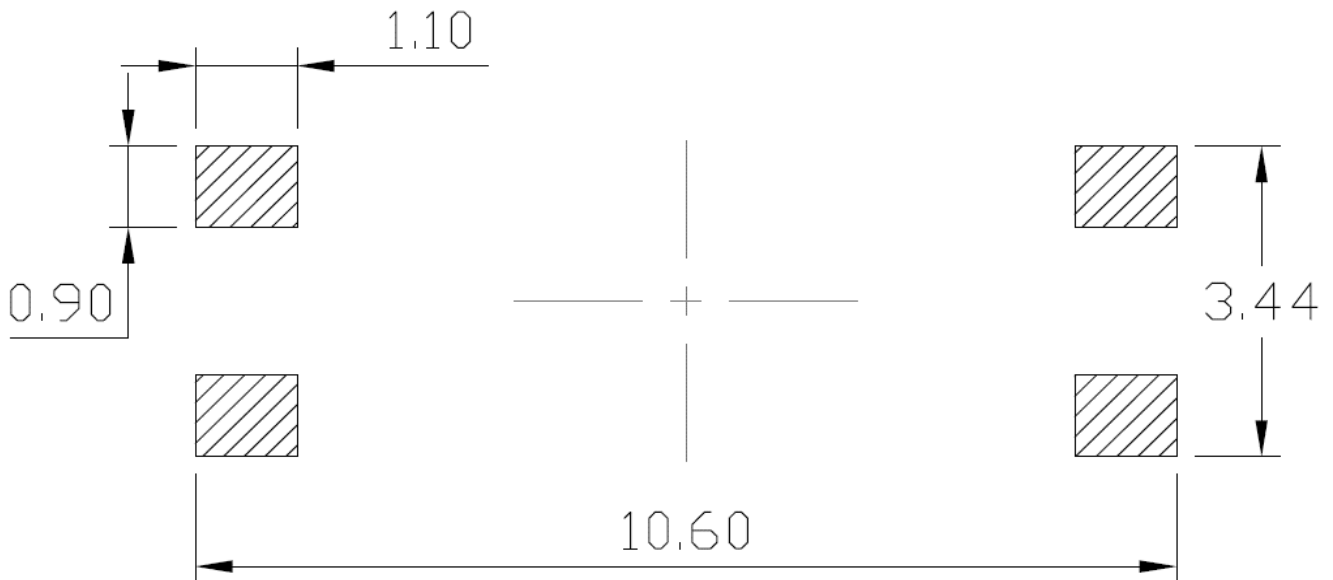
**Fig.4 Collector Dark Current vs. Ambient Temperature**

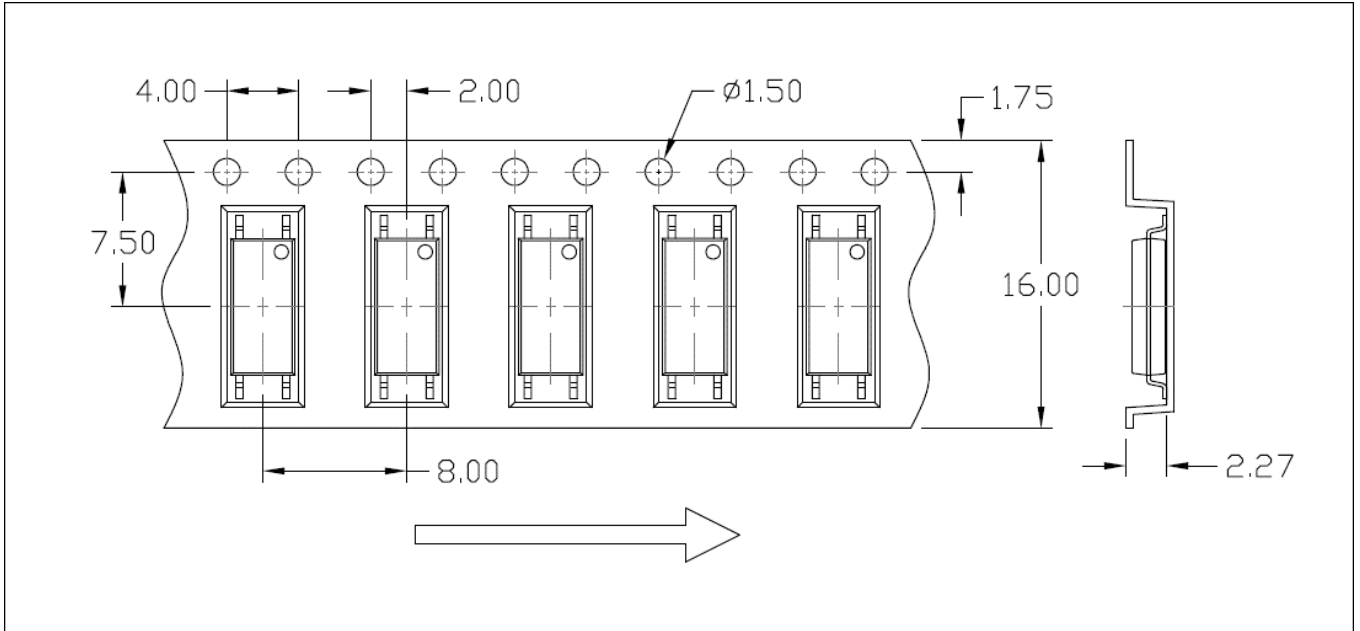
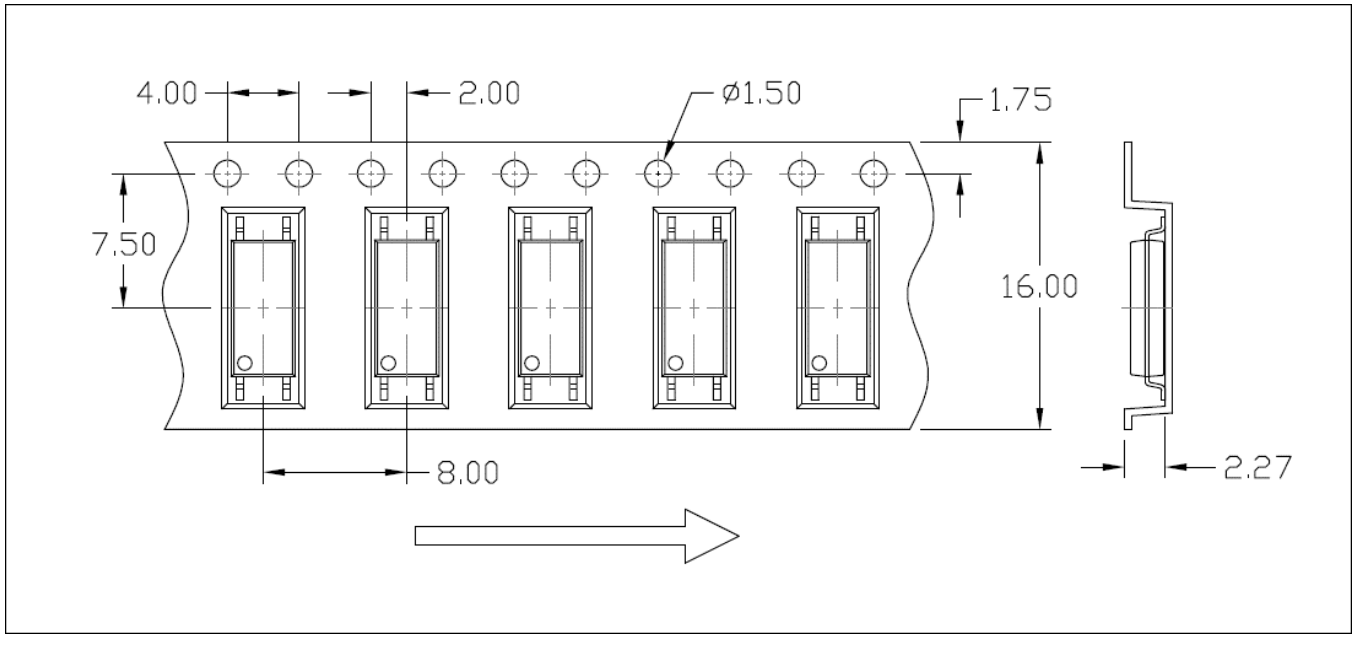
**Fig.5 Collector Current vs. Collector-emitter Voltage**

**Fig.6 Collector Current vs. Collector-emitter Voltage**

**LSOP4, DC Input, Photo Transistor Coupler**
**CHARACTERISTIC CURVES**
**Fig.7 Normalized Current Transfer Ratio vs. Forward Current**

**Fig.8 Normalized Current Transfer Ratio vs. Ambient Temperature**

**Fig.9 Collector-emitter Saturation Voltage vs. Ambient Temperature**

**Fig.10 Switching Time vs. Load Resistance**

**Fig.11 Frequency Response**

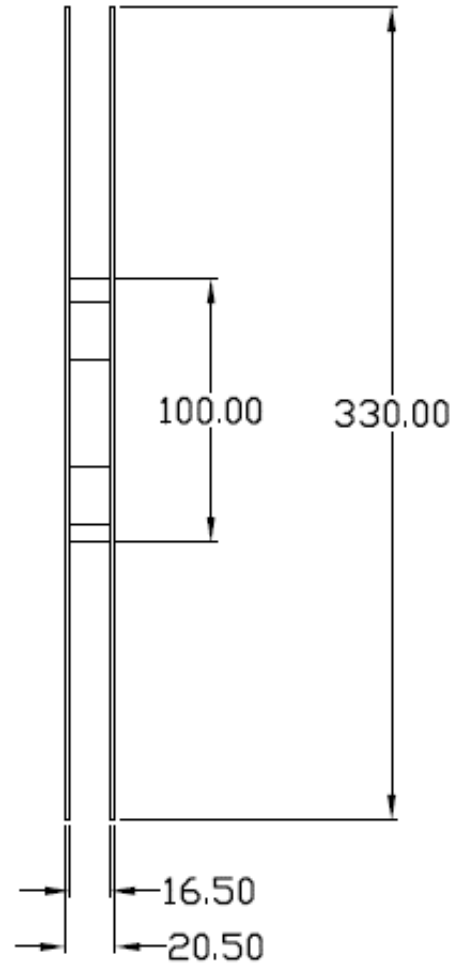
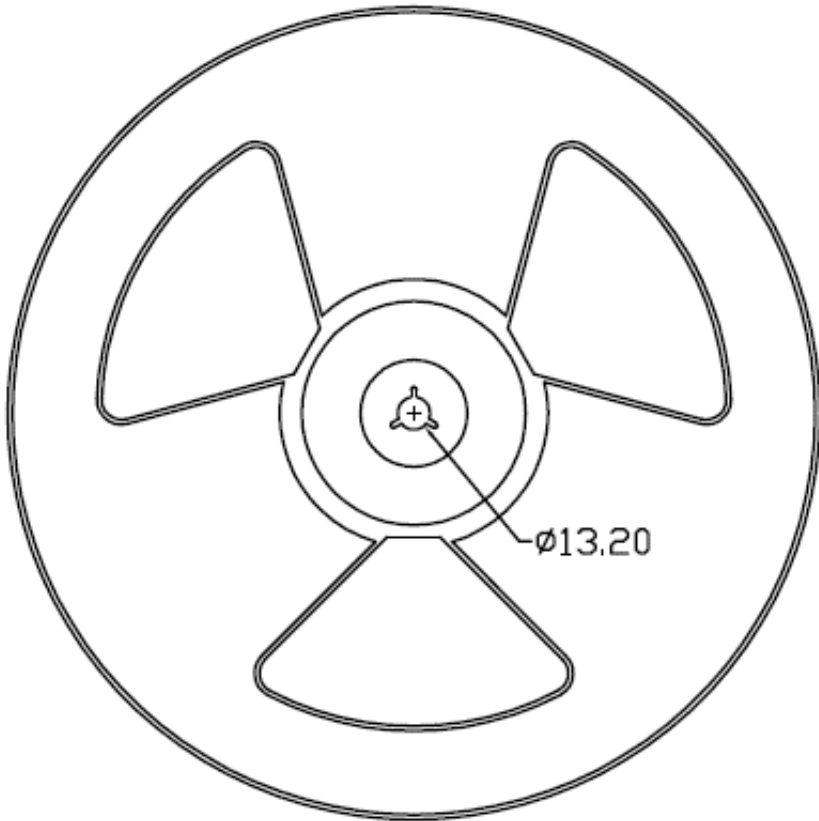
**LSOP4, DC Input, Photo Transistor Coupler**
**TEST CIRCUITS**
**Fig.12 Test Circuits of Response Time**

**Fig.13 Curves of Response Time**

**Fig.14 Test Circuits of Frequency Response**

**LSOP4, DC Input, Photo Transistor Coupler**
**PACKAGE DIMENSIONS (Dimensions in mm unless otherwise stated)**

**RECOMMENDED SOLDER MASK (Dimensions in mm unless otherwise stated)**

**LSOP4, DC Input, Photo Transistor Coupler**
**CARRIER TAPE SPECIFICATIONS (Dimensions in mm unless otherwise stated)**
**Packing Option 1**

**Packing Option 2**



**LSOP4, DC Input, Photo Transistor Coupler**
**REEL SPECIFICATIONS (Dimensions in mm unless otherwise stated)**
**Reel Dimension**

**LSOP4, DC Input, Photo Transistor Coupler**

**BOX SPECIFICATIONS (Reel Type)**

**Inner Box**

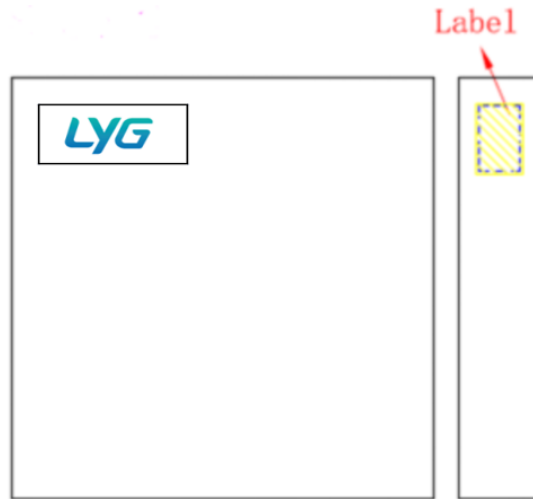

- L x W x H = 36cm x 36cm x 6.9cm

**Outer Box**

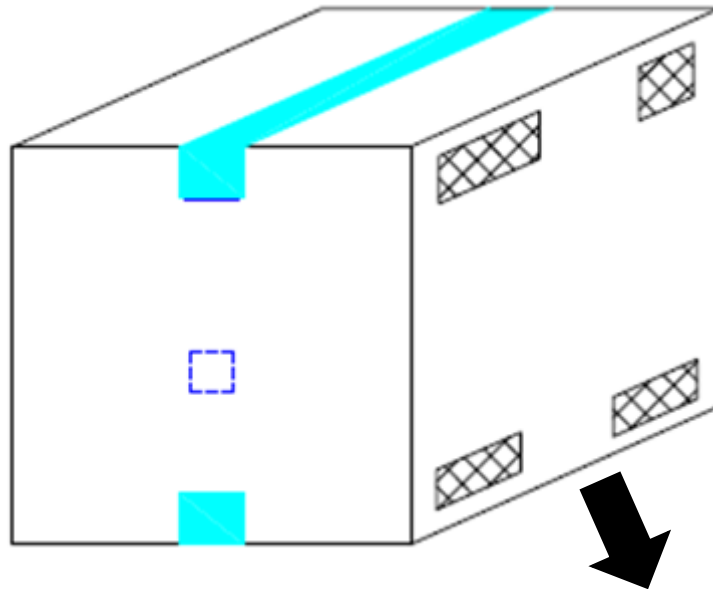

- L x W x H = 45cm x 38cm x 38cm





LSOP4, DC Input, Photo Transistor Coupler

ORDERING AND MARKING INFORMATION

MARKING INFORMATION



**LYG** : Company Abbr.  
**FX101** : Part Number  
**R** : CTR Rank Option  
**V** : VDE Option  
**Y** : Fiscal Year  
**A** : Manufacturing Code  
**WW** : Work Week

ORDERING INFORMATION

LABEL INFORMATION

**FX101RBTH-0ZP3GC**

FX101 – Part Number  
 R – Rank Option (0/1/2/3/4/5/6/7/8/9)  
 V – VDE Option (V or N)  
 BTH – Fixed Character  
 0 – Fixed Character  
 Z – Packing Option (1/3)  
 P3 – Fixed Character  
 G – Halogen free (G or None)  
 C – Color Option (B or W)

**LYG Semiconductor**

DEVICE: F\*\*\*\*\*\_\*  
 LOT NO: F4HM74.1-01  
 DATE CODE: 210101  
 QTY(EA): 3000  
 DATE: 2021/02/08

MSL: 1  
 CEC  
 Pb  
 RoHS / H.F.  
 QC Stamp

PACKING QUANTITY

Option	Quantity	Quantity – Inner box	Quantity – Outer box
1	3000 Units/Reel	3 Reels/Inner box	5 Inner box/Outer box = 45k Units
2	3000 Units/Reel	3 Reels/Inner box	5 Inner box/Outer box = 45k Units

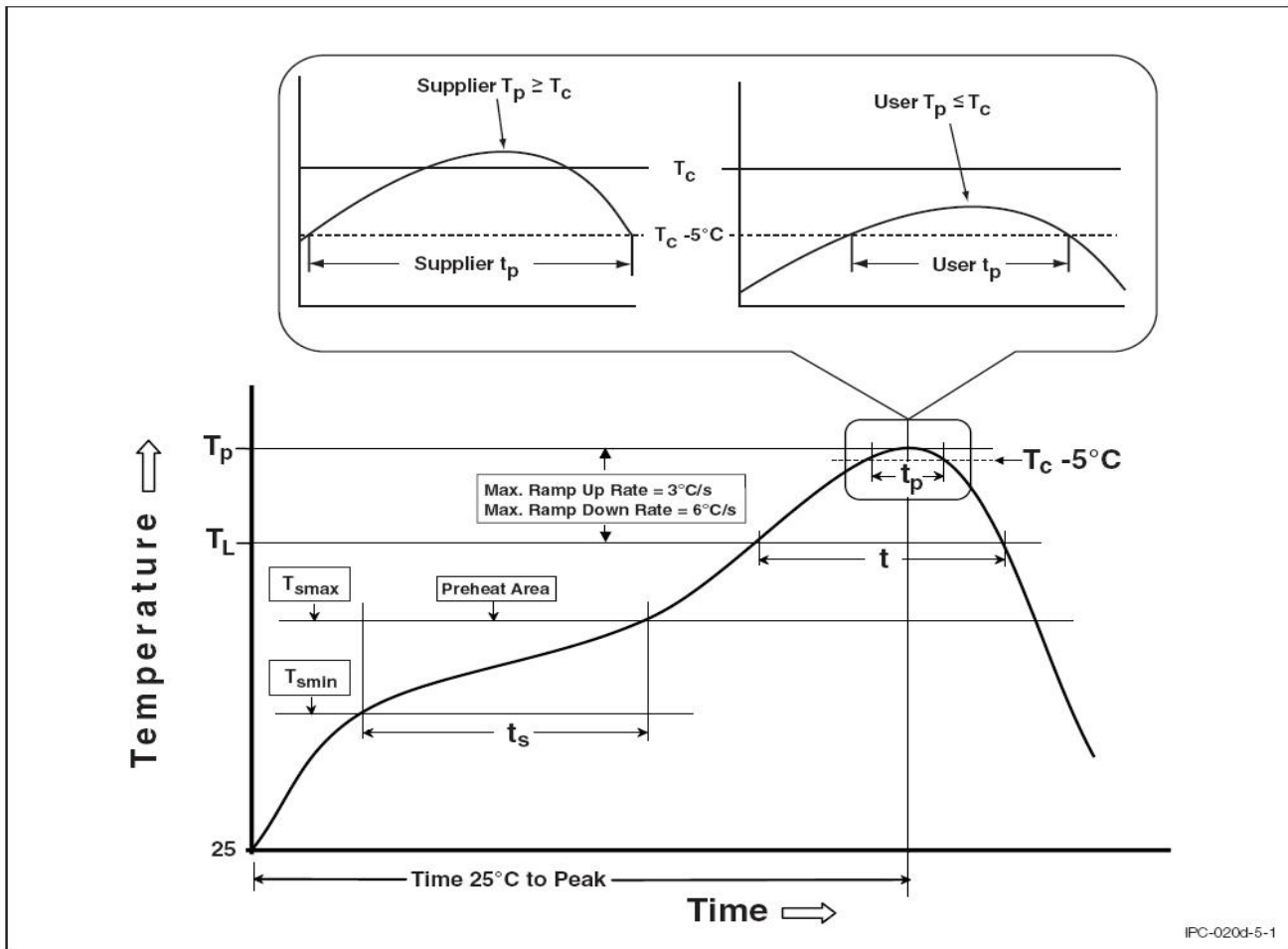
**LSOP4, DC Input, Photo Transistor Coupler**
**TEMPERATURE PROFILE OF SOLDERING**
**IR REFLOW SOLDERING (J-STD-020D COMPLIANT)**

Profile Feature	Sn-Pb Assembly Profile	Pb-Free Assembly Profile
Temperature Min. (T <sub>smin</sub> )	100	150°C
Temperature Max. (T <sub>smax</sub> )	150	200°C
Time (t <sub>s</sub> ) from (T <sub>smin</sub> to T <sub>smax</sub> )	60-120 seconds	60-120 seconds
Ramp-up Rate (t <sub>L</sub> to t <sub>P</sub> )	3°C/second max.	3°C/second max.
Liquidous Temperature (T <sub>L</sub> )	183°C	217°C
Time (t <sub>L</sub> ) Maintained Above (T <sub>L</sub> )	60 – 150 seconds	60 – 150 seconds
Peak Body Package Temperature	235°C +0°C / -5°C	260°C +0°C / -5°C
Time (t <sub>P</sub> ) within 5°C of 260°C	20 seconds	30 seconds
Ramp-down Rate (T <sub>P</sub> to T <sub>L</sub> )	6°C/second max	6°C/second max
Time 25°C to Peak Temperature	6 minutes max.	8 minutes max.



**LSOP4, DC Input, Photo Transistor Coupler**

**TEMPERATURE PROFILE OF SOLDERING**

**WAVE SOLDERING (JESD22-A111 COMPLIANT)**

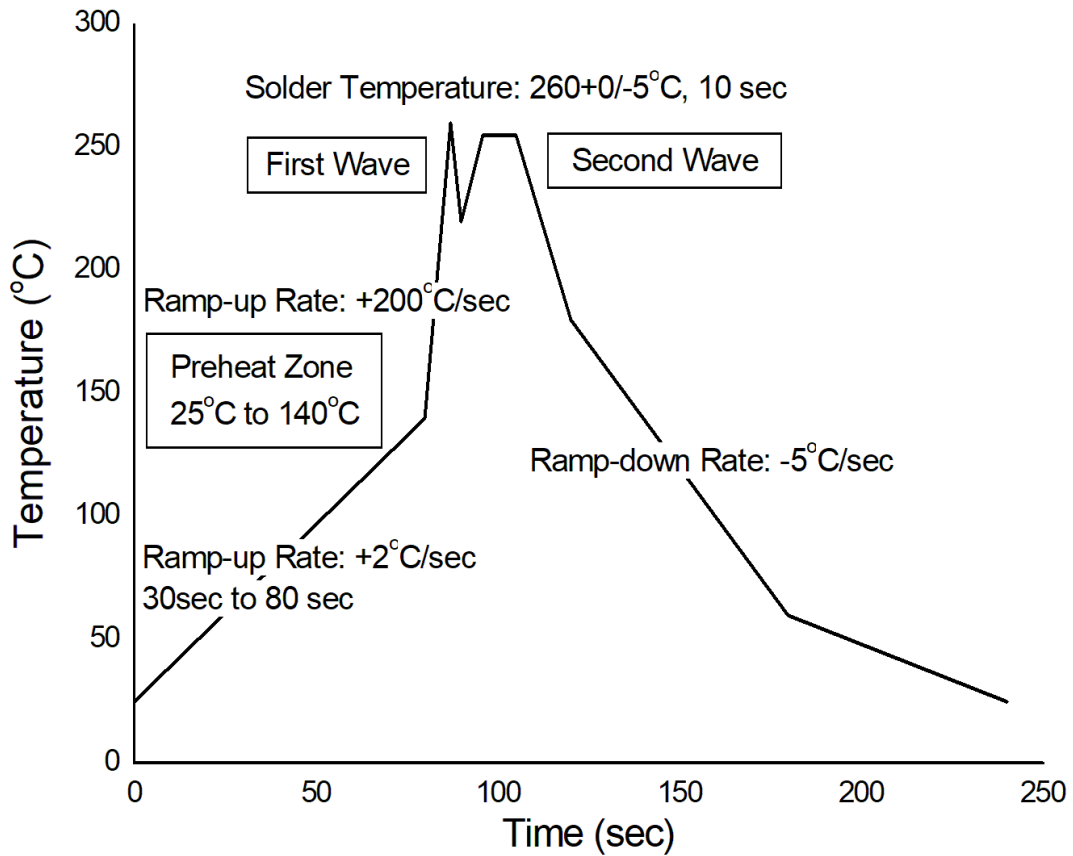

**HAND SOLDERING BY SOLDERING IRON**

Soldering Temperature	380+0/-5°C
Soldering Time	3 sec max.

- One time soldering is recommended for all soldering method.
- Do not solder more than three times for IR reflow soldering.



**LSOP4, DC Input, Photo Transistor Coupler**

**DISCLAIMER**

- LYG is continually improving the quality, reliability, function and design. LYG reserves the right to make changes without further notices.
- The characteristic curves shown in this datasheet are representing typical performance which are not guaranteed.
- LYG makes no warranty, representation or guarantee regarding the suitability of the products for any particular purpose or the continuing production of any product. To the maximum extent permitted by applicable law, LYG disclaims (a) any and all liability arising out of the application or use of any product, (b) any and all liability, including without limitation special, consequential or incidental damages, and (c) any and all implied warranties, including warranties of fitness for particular
- The products shown in this publication are designed for the general use in electronic applications such as office automation, equipment, communications devices, audio/visual equipment, electrical application and instrumentation purpose, non-infringement and merchantability.
- This product is not intended to be used for military, aircraft, automotive, medical, life sustaining or lifesaving applications or any other application which can result in human injury or death.
- Please contact LYG sales agent for special application request.
- Immerge unit's body in solder paste is not recommended.
- Parameters provided in datasheets may vary in different applications and performance may vary over time. All operating parameters, including typical parameters, must be validated in each customer application by the customer's technical experts. Product specifications do not expand or otherwise modify LYG's terms and conditions of purchase, including but not limited to the warranty expressed therein.
- Discoloration might be occurred on the package surface after soldering, reflow or long-time use. It neither impacts the performance nor reliability.