

MELSEC FX Family

Programmable Logic Controllers

Beginners Manual

**FX1S, FX1N,
FX2N, FX2NC,
FX3U**

About This Manual

The texts, illustration, diagrams and examples in this manual are provided for information purposes only.

They are intended as aids to help explain the installation, operation, programming and use of the programmable logic controllers of the MELSEC FX1S, FX1N, FX2N,FX2NC and FX3U series.

If you have any questions about the installation and operation of any of the products described in this manual please contact your local sales office or distributor (see inside back cover).

You can find the latest information and answers to frequently asked questions on our website at www.mitsubishi-automation.com.

MITSUBISHI ELECTRIC EUROPE BV reserves the right to make changes to this manual or the technical specifications of its products at any time without notice.

© 04/2006

Beginner's Manual for the programmable logic controllers of the MELSEC FX family
FX1S, FX1N, FX2N, FX2NC und FX3U
Art. no.: 166388

Version			Revisions / Additions / Corrections
A	04/2006	pdp-tr	First edition

Safety Guidelines

For use by qualified staff only

This manual is only intended for use by properly trained and qualified electrical technicians who are fully acquainted with the relevant automation technology safety standards. All work with the hardware described, including system design, installation, configuration, maintenance, service and testing of the equipment, may only be performed by trained electrical technicians with approved qualifications who are fully acquainted with all the applicable automation technology safety standards and regulations. Any operations or modifications to the hardware and/or software of our products not specifically described in this manual may only be performed by authorised Mitsubishi Electric staff.

Proper use of the products

The programmable logic controllers of the FX1S, FX1N, FX2N, FX2NC and FX3U series are only intended for the specific applications explicitly described in this manual. All parameters and settings specified in this manual must be observed. The products described have all been designed, manufactured, tested and documented in strict compliance with the relevant safety standards. Unqualified modification of the hardware or software or failure to observe the warnings on the products and in this manual may result in serious personal injury and/or damage to property. Only peripherals and expansion equipment specifically recommended and approved by Mitsubishi Electric may be used with the programmable logic controllers of the FX1S, FX1N, FX2N, FX2NC and FX3U series.

All and any other uses or application of the products shall be deemed to be improper.

Relevant safety regulations

All safety and accident prevention regulations relevant to your specific application must be observed in the system design, installation, configuration, maintenance, servicing and testing of these products. The regulations listed below are particularly important in this regard. This list does not claim to be complete, however; you are responsible for being familiar with and conforming to the regulations applicable to you in your location.

- VDE Standards
 - VDE 0100
Regulations for the erection of power installations with rated voltages below 1000 V
 - VDE 0105
Operation of power installations
 - VDE 0113
Electrical installations with electronic equipment
 - VDE 0160
Electronic equipment for use in power installations
 - VDE 0550/0551
Regulations for transformers
 - VDE 0700
Safety of electrical appliances for household use and similar applications
 - VDE 0860
Safety regulations for mains-powered electronic appliances and their accessories for household use and similar applications.

- Fire safety regulations

- Accident prevention regulations
 - VBG Nr.4
Electrical systems and equipment

Safety warnings in this manual

In this manual warnings that are relevant for safety are identified as follows:



DANGER:

Failure to observe the safety warnings identified with this symbol can result in health and injury hazards for the user.



WARNING:

Failure to observe the safety warnings identified with this symbol can result in damage to the equipment or other property.

General safety information and precautions

The following safety precautions are intended as a general guideline for using PLC systems together with other equipment. These precautions must always be observed in the design, installation and operation of all control systems.



DANGER:

- **Observe all safety and accident prevention regulations applicable to your specific application. Always disconnect all power supplies before performing installation and wiring work or opening any of the assemblies, components and devices.**
- **Assemblies, components and devices must always be installed in a shockproof housing fitted with a proper cover and fuses or circuit breakers.**
- **Devices with a permanent connection to the mains power supply must be integrated in the building installations with an all-pole disconnection switch and a suitable fuse.**
- **Check power cables and lines connected to the equipment regularly for breaks and insulation damage. If cable damage is found immediately disconnect the equipment and the cables from the power supply and replace the defective cabling.**
- **Before using the equipment for the first time check that the power supply rating matches that of the local mains power.**
- **Take appropriate steps to ensure that cable damage or core breaks in the signal lines cannot cause undefined states in the equipment.**
- **You are responsible for taking the necessary precautions to ensure that programs interrupted by brownouts and power failures can be restarted properly and safely. In particular, you must ensure that dangerous conditions cannot occur under any circumstances, even for brief periods.**
- **EMERGENCY OFF facilities conforming to EN 60204/IEC 204 and VDE 0113 must remain fully operative at all times and in all PLC operating modes. The EMERGENCY OFF facility reset function must be designed so that it cannot ever cause an uncontrolled or undefined restart.**
- **You must implement both hardware and software safety precautions to prevent the possibility of undefined control system states caused by signal line cable or core breaks.**
- **When using modules always ensure that all electrical and mechanical specifications and requirements are observed exactly.**

Contents

1	Introduction	
1.1	About this Manual	1-1
1.2	More Information	1-1
2	Programmable Logic Controllers	
2.1	What is a PLC?	2-1
2.2	How PLCs Process Programs	2-2
2.3	The MELSEC FX Family	2-4
2.4	Selecting the Right Controller	2-5
2.5	Controller Design	2-6
2.5.1	Input and output circuits	2-6
2.5.2	Layout of the MELSEC FX1S base units	2-6
2.5.3	Layout of the MELSEC FX1N base units	2-7
2.5.4	Layout of the MELSEC FX2N base units	2-7
2.5.5	Layout of the MELSEC FX2NC base units	2-8
2.5.6	Layout of the MELSEC FX3U base units	2-8
2.5.7	PLC components glossary	2-9
3	An Introduction to Programming	
3.1	Structure of a Program Instruction.	3-1
3.2	Bits, Bytes and Words	3-2
3.3	Number Systems	3-2
3.4	The Basic Instruction Set.	3-5
3.4.1	Starting logic operations	3-6
3.4.2	Outputting the result of a logic operation	3-6
3.4.3	Using switches and sensors	3-8
3.4.4	AND operations	3-9
3.4.5	OR operations	3-11
3.4.6	Instructions for connecting operation blocks	3-12
3.4.7	Pulse-triggered execution of operations	3-14
3.4.8	Setting and resetting devices	3-15
3.4.9	Storing, reading and deleting operation results	3-17

3.4.10	Generating pulses	3-18
3.4.11	Master control function (MC and MCR instructions)	3-19
3.4.12	Inversion of an Operation Result	3-20
3.5	Safety First!	3-21
3.6	Programming PLC Applications	3-23
3.6.1	An alarm system	3-23
3.6.2	A rolling shutter gate	3-28

4 Devices in Detail

4.1	Inputs and Outputs	4-1
4.2	Relays	4-3
4.2.1	Special relays	4-3
4.3	Timers	4-4
4.4	Counters	4-7
4.5	Registers	4-9
4.5.1	Data registers	4-9
4.5.2	Special registers	4-10
4.5.3	File registers	4-11
4.6	Programming Tips for Timers and Counters	4-11
4.6.1	Specifying timer and counter setpoints indirectly	4-11
4.6.2	Switch-off delay	4-14
4.6.3	Delayed make and break	4-15
4.6.4	Clock signal generators	4-16

5 More Advanced Programming

5.1	Applied Instructions Reference	5-1
5.1.1	Entering applied instructions	5-6
5.2	Instructions for Moving Data	5-7
5.2.1	Moving individual values with the MOV instruction	5-7
5.2.2	Moving groups of bit devices	5-9
5.2.3	Moving blocks of data with the BMOV instruction	5-10
5.2.4	Copying source devices to multiple destinations (FMOV)	5-11
5.2.5	Exchanging data with special function modules	5-12

5.3	Compare Instructions	5-15
5.3.1	The CMP instruction	5-15
5.3.2	Comparisons within logic operations.	5-17
5.4	Math Instructions	5-20
5.4.1	Addition	5-21
5.4.2	Subtraction	5-22
5.4.3	Multiplication	5-23
5.4.4	Division	5-24
5.4.5	Combining math instructions.	5-25

6 Expansion Options

6.1	Introduction	6-1
6.2	Available Modules	6-1
6.2.1	Modules for adding more digital inputs and outputs	6-1
6.2.2	Analog I/O modules.	6-1
6.2.3	Communications modules	6-2
6.2.4	Positioning modules	6-2
6.2.5	HMI control and display panels	6-2

1 Introduction

1.1 About this Manual

This manual will help you to familiarise yourself with the use of the MELSEC FX family of programmable logic controllers. It is designed for users who do not yet have any experience with programming programmable logic controllers (PLCs).

Programmers who already have experience with PLCs from other manufacturers can also use this manual as a guide for making the transition to the MELSEC FX family.

The symbol „□“ is used as a placeholder to identify different controllers in the same range. For example, the designation "FX1S-10□-□□" is used to refer to all controllers whose name begins with FX1S-10, i.e. FX1S-10 MR-DS, FX1S-10 MR-ES/UL, FX1S-10 MT-DSS and FX1S-10 MT-ESS/UL.

1.2 More Information

You can find more detailed information on the individual products in the series in the operating and installation manuals of the individual modules.

See the MELSEC FX Family Catalogue, art. no. 167840, for a general overview of all the controllers in the MELSEC FX family. This catalogue also contains information on expansion options and the available accessories.

For an introduction to using the programming software package see the GX Developer FX Beginner's Manual, art. no. 166391.

You can find detailed documentation of all programming instructions in the Programming Manual for the MELSEC FX family, art. no. 132738 and in the Programming Manual for the FX3U series, art. no. 168591.

The communications capabilities and options of the MELSEC FX controllers are documented in detail in the Communications Manual, art. no. 070143.

All Mitsubishi manuals and catalogues can be downloaded free of charge from the Mitsubishi website at www.mitsubishi-automation.com.

2 Programmable Logic Controllers

2.1 What is a PLC?

In contrast to conventional controllers with functions determined by their physical wiring the functions of programmable logic controllers or PLCs are defined by a program. PLCs also have to be connected to the outside world with cables, but the contents of their program memory can be changed at any time to adapt their programs to different control tasks.

Programmable logic controllers input data, process it and then output the results. This process is performed in three stages:

- an input stage,
 - a processing stage
- and
- an output stage

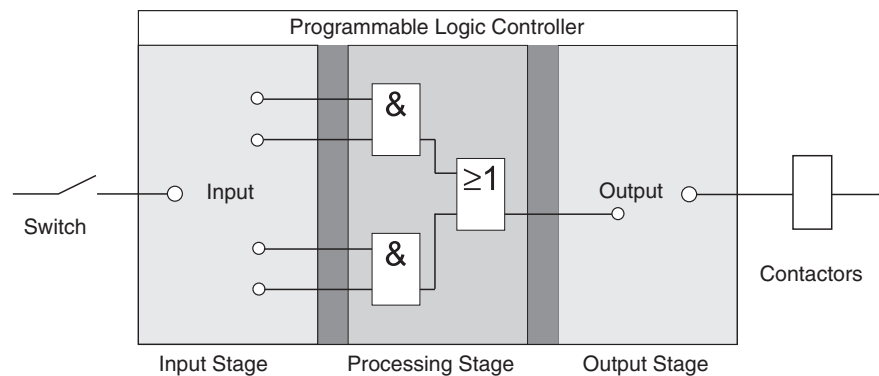

The input stage

The input stage passes control signals from switches, buttons or sensors on to the processing stage.

The signals from these components are generated as part of the control process and are fed to the inputs as logical states. The input stage passes them on to the processing stage in a pre-processed format.

The processing stage

In the processing stage the pre-processed signals from the input stage are processed and combined with the help of logical operations and other functions. The program memory of the processing stage is fully programmable. The processing sequence can be changed at any time by modifying or replacing the stored program.

The output stage

The results of the processing of the input signals by the program are fed to the output stage where they control connected switchable elements such as contactors, signal lamps, solenoid valves and so on.

2.2 How PLCs Process Programs

A PLC performs its tasks by executing a program that is usually developed outside the controller and then transferred to the controller’s program memory. Before you start programming it is useful to have a basic understanding of how PLCs process these programs.

A PLC program consists of a sequence of instructions that control the functions of the controller. The PLC executes these control instructions sequentially, i.e. one after another. The entire program sequence is cyclical, which means that it is repeated in a continuous loop. The time required for one program repetition is referred to as the program cycle time or period.

Process image processing

The program in the PLC is not executed directly on the inputs and outputs, but on a “process image” of the inputs and outputs:

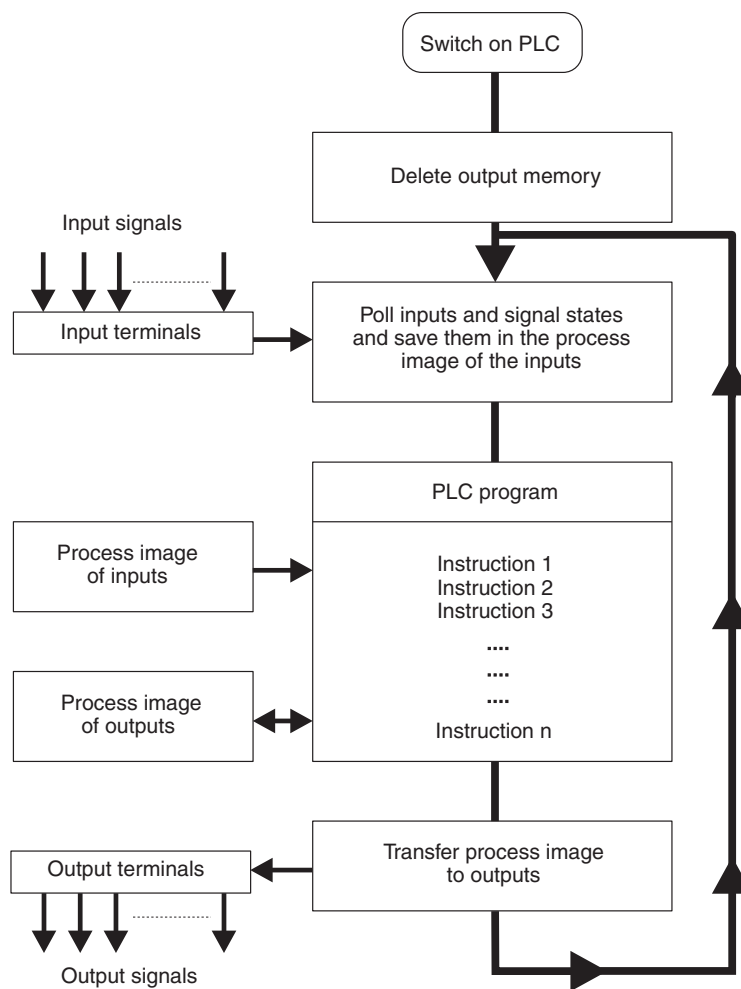

Input process image

At the beginning of each program cycle the system polls the signal states of the inputs and stores them in a buffer, creating a “process image” of the inputs.

Program execution

After this the program is executed, during which the PLC accesses the stored states of the inputs in the process image. This means that any subsequent changes in the input states will not be registered until the **next** program cycle!

The program is executed from top to bottom, in the order in which the instructions were programmed. Results of individual programming steps are stored and can be used during the current program cycle.

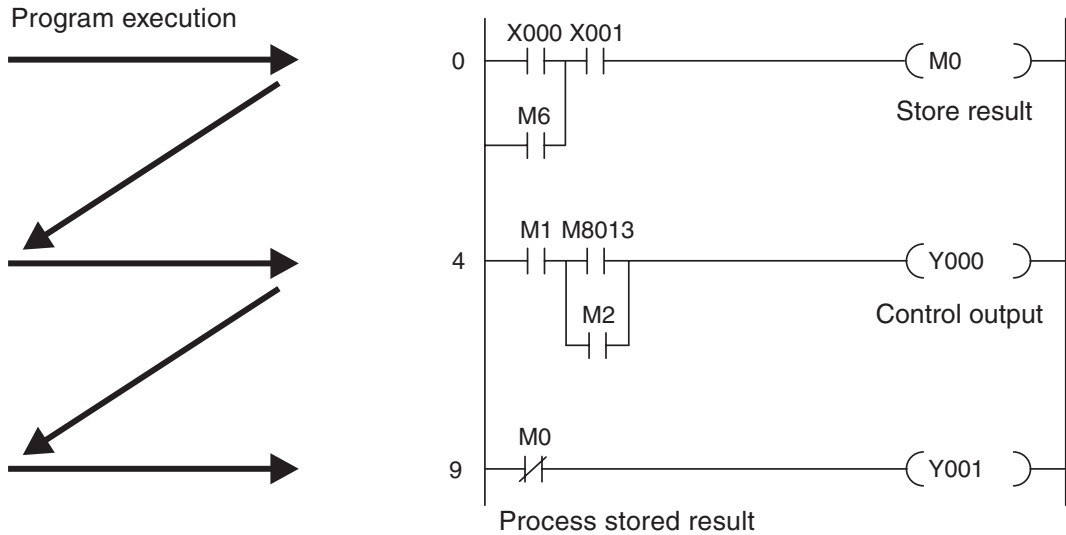

Output process image

Results of logical operations that are relevant for the outputs are stored in an output buffer – the output process image. The output process image is stored in the output buffer until the buffer is rewritten. After the values have been written to the outputs the program cycle is repeated.

Differences between signal processing in the PLC and in hard-wired controllers

In hard-wired controllers the program is defined by the functional elements and their connections (the wiring). All control operations are performed simultaneously (parallel execution). Every change in an input signal state causes an instantaneous change in the corresponding output signal state.

In a PLC it is not possible to respond to changes in input signal states until the next program cycle after the change. Nowadays this disadvantage is largely compensated by very short program cycle periods. The duration of the program cycle period depends on the number and type of instructions executed.

2.3 The MELSEC FX Family

The compact micro-controllers of the MELSEC FX series provide the foundation for building economical solutions for small to medium-sized control and positioning tasks requiring 10 to 256 integrated inputs and outputs in applications in industry and building services.

With the exception of the FX1S all the controllers of the FX series can be expanded to keep pace with the changes in the application and the user's growing requirements.

Network connections are also supported. This makes it possible for the controllers of the FX family to communicate with other PLCs and controller systems and HMIs (Human-Machine Interfaces and control panels). The PLC systems can be integrated both in MITSUBISHI networks as local stations and as slave stations in open networks like PROFIBUS/DP.

In addition to this you can also build multi-drop and peer-to-peer networks with the controllers of the MELSEC FX family.

The FX1N, FX2N and FX3U have modular expansion capabilities, making them the right choice for complex applications and tasks requiring special functions like analog-digital and digital-analog conversion and network capabilities.

All the controllers in the series are part of the larger MELSEC FX family and are fully compatible with one another.

Specifications	FX1S	FX1N	FX2N	FX2NC	FX3U
Max integrated I/O points	30	60	128	96	80
Expansion capability (max. possible I/Os)	34	132	256	256	384
Program memory (steps)	2000	8000	16000	16000	64000
Cycle time per log. instruction (μ s)	0,55 – 0,7	0,55 – 0,7	0,08	0,08	0,065
No. of instructions (standard / step ladder / special function)	27 / 2 / 85	27 / 2 / 89	27 / 2 / 107	27 / 2 / 107	27 / 2 / 209
Max. special function modules connectable	—	2	8	4	8 right 10 left

2.4 Selecting the Right Controller

The base units of the MELSEC FX1S, FX1N and FX2N(C) series are available in a number of different versions with different power supply options and output technologies. You can choose between units designed for power supplies of 100–240 V AC, 24 V DC or 12–24 V DC, and between relay and transistor outputs. The controllers of the FX3U series are currently only available for AC power supply and with relay outputs.

Series	I/Os	Type	No. of inputs	No. of outputs	Power supply	Output type
FX1S	10	FX1S-10 M□-□□	6	8	24 V DC or 100 – 240 V AC	Transistor or relay
	14	FX1S-14 M□-□□	8	6		
	20	FX1S-20 M□-□□	12	8		
	30	FX1S-30 M□-□□	16	14		
FX1N	14	FX1N-14 M□-□□	8	6	12 – 24 V DC or 100 – 240 V AC	Transistor or relay
	24	FX1N-24 M□-□□	14	10		
	40	FX1N-40 M□-□□	24	16		
	60	FX1N-60 M□-□□	36	24		
FX2N	16	FX2N-16 M□-□□	8	8	Wahlweise 24 V DC oder 100 – 240 V AC	Transistor or relay
	32	FX2N-32 M□-□□	16	16		
	48	FX2N-48 M□-□□	24	24		
	64	FX2N-64 M□-□□	32	32		
	80	FX2N-80 M□-□□	40	40		
	128	FX2N-128 M□-□□	64	64		
FX2NC	16	FX2NC-16 M□-□□	8	8	24 V DC	Transistor or relay
	32	FX2NC-32 M□-□□	16	16		
	64	FX2NC-64 M□-□□	32	32		
	96	FX2NC-96 M□-□□	48	48		
FX3U	16	FX3U-16 MR/ES	8	8	100 – 240 V AC	Relay only
	32	FX3U-32 MR/ES	16	16		
	48	FX3U-48 MR/ES	24	24		
	64	FX3U-64 MR/ES	32	32		
	80	FX3U-80 MR/ES	40	40		

To choose the right controller for your application you need to answer the following questions:

- How many signals (external switch contacts, buttons and sensors) do you need to input?
- What types of functions do you need to switch, and how many of them are there?
- What power supply options are available?
- How high are the loads that the outputs need to switch? Choose relay outputs for switching high loads and transistor outputs for switching fast, trigger-free switching operations.

2.5 Controller Design

All the controllers in the series have the same basic design. The main functional elements and assemblies are described in the glossary in section 2.5.7.

2.5.1 Input and output circuits

The **input circuits** use floating inputs. They are electrically isolated from the other circuits of the PLC with optical couplers. The **output circuits** use either relay or transistor output technology. The transistor outputs are also electrically isolated from the other PLC circuits with optical couplers.

The switching voltage at all the digital inputs must have a certain value (e.g. 24 V DC). This voltage can be taken from the PLC's integrated power supply unit. If the switching voltage at the inputs is less than the rated value (e.g. <24 V DC) then the input will not be processed.

The maximum output currents are 2 A on 250 V three-phase AC and non-reactive loads with relay outputs and 0.5 A on 24 V DC and non-reactive loads.

2.5.2 Layout of the MELSEC FX1S base units

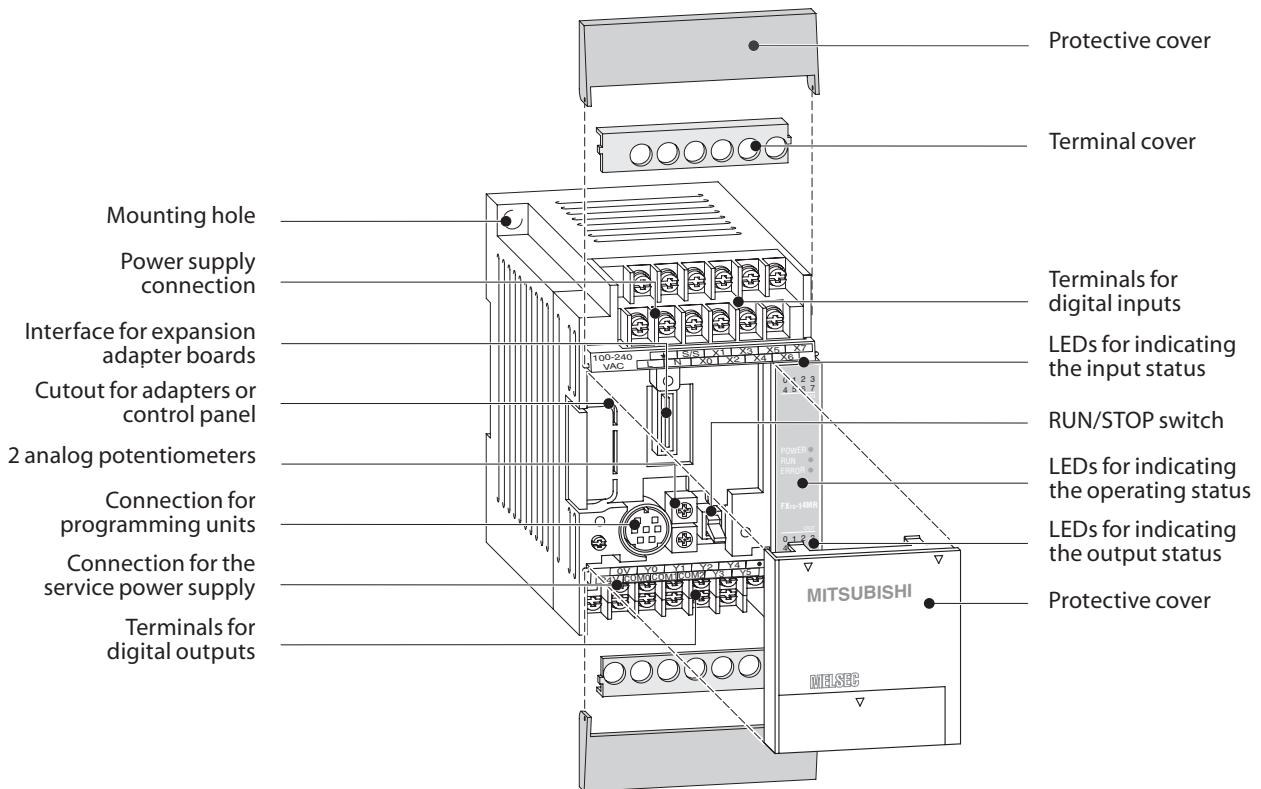

2.5.3 Layout of the MELSEC FX1N base units

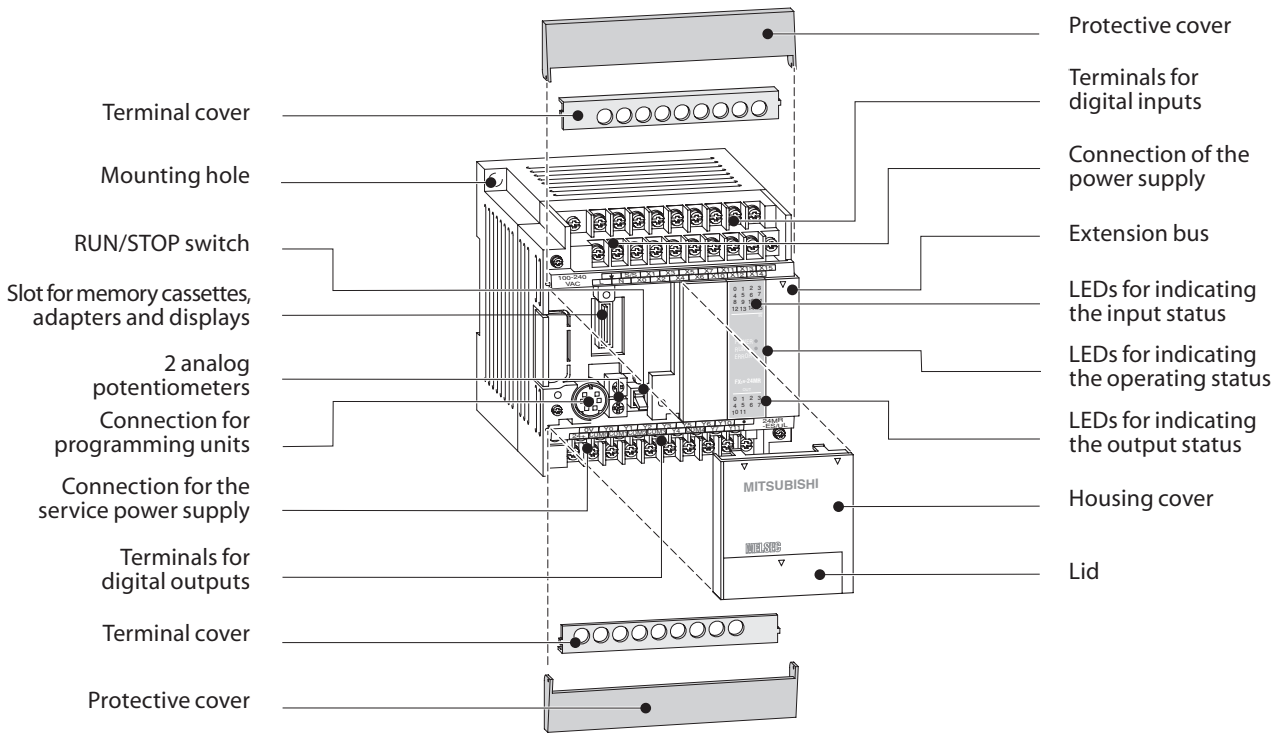

2.5.4 Layout of the MELSEC FX2N base units

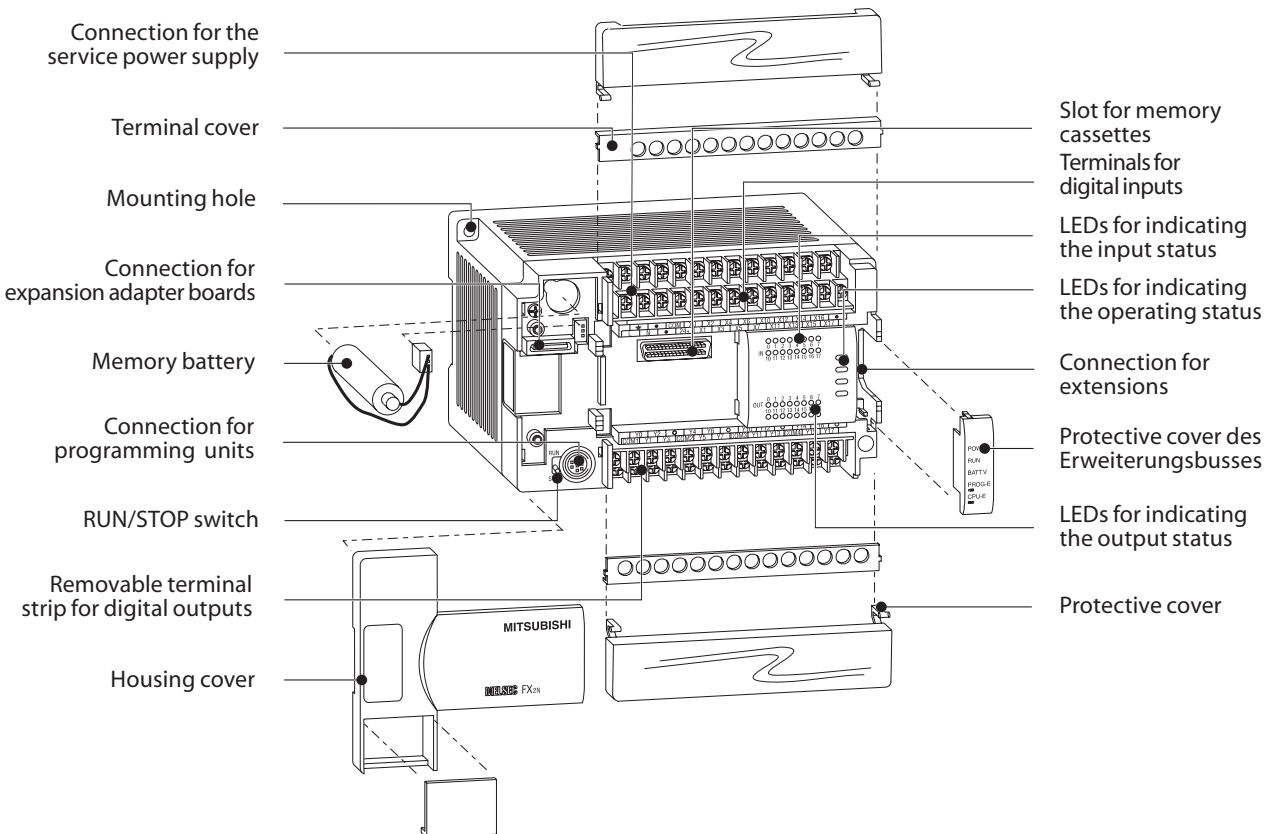

2.5.5 Layout of the MELSEC FX2NC base units

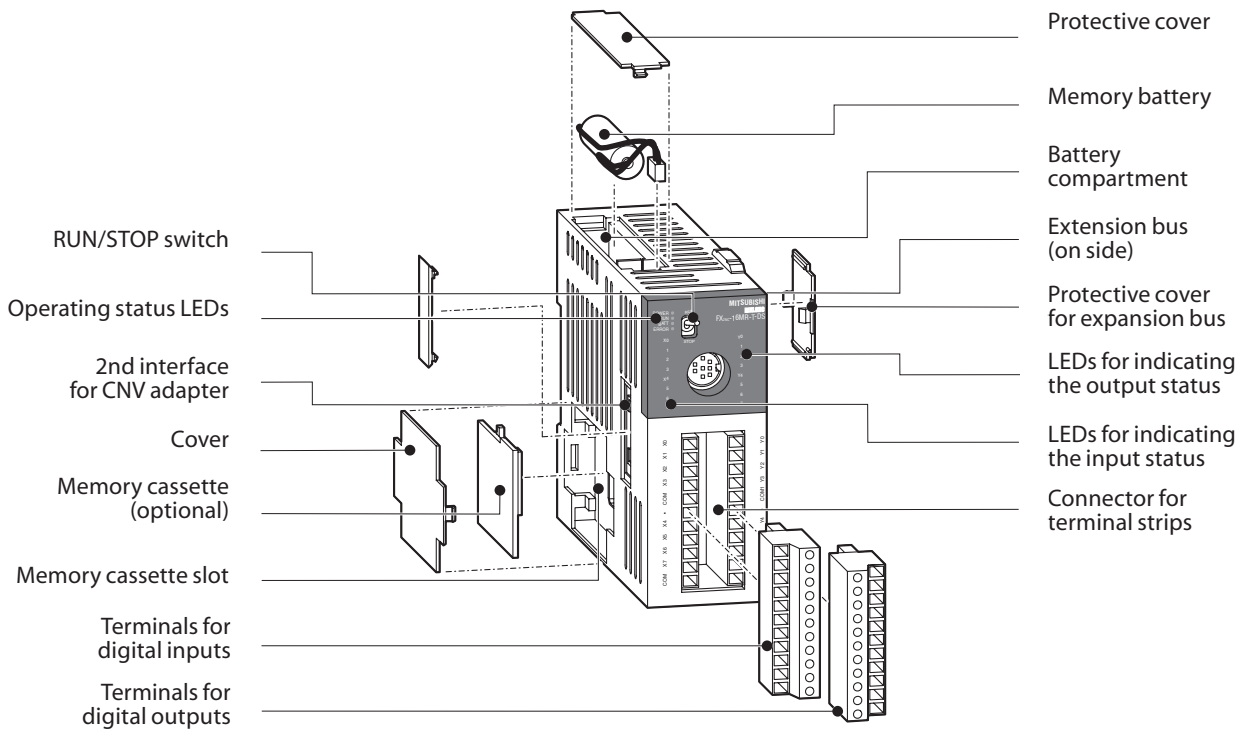

2.5.6 Layout of the MELSEC FX3U base units

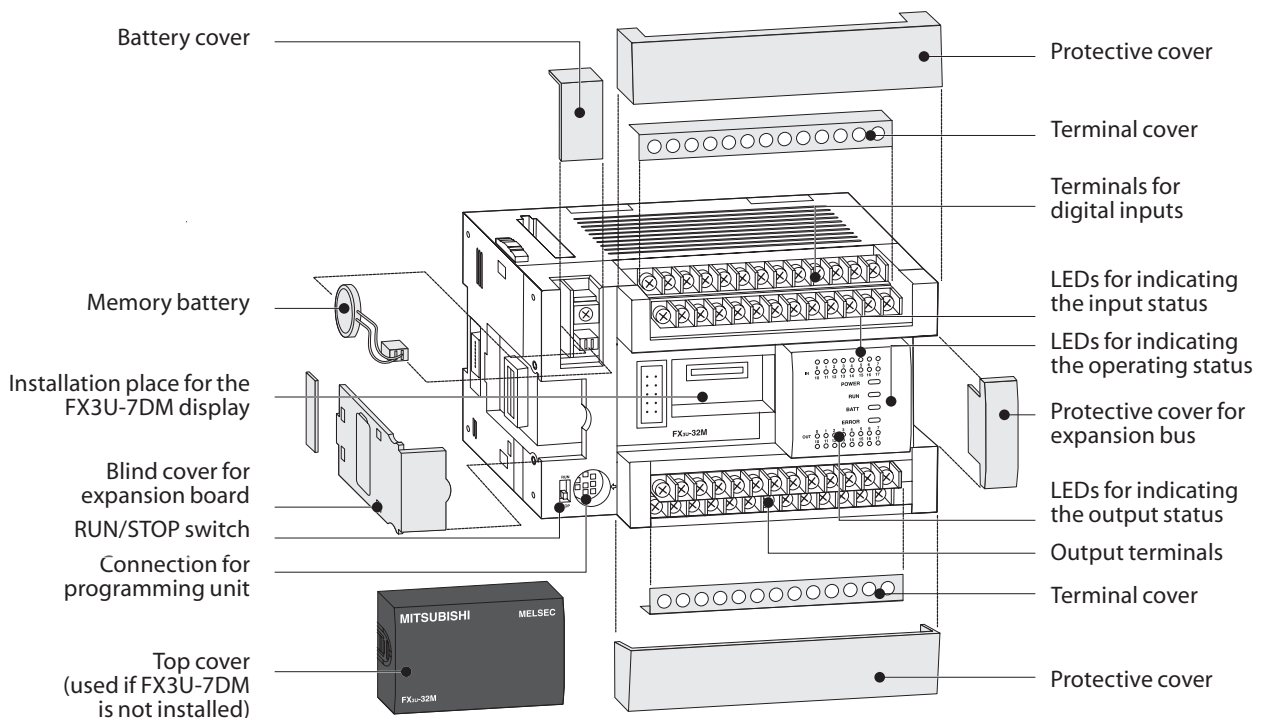

2.5.7 PLC components glossary

The following table describes the meaning and functionality of the single components and parts of a Mitsubishi PLC.

Component	Description
Connection for expansion adapter boards	Optional expansion adapter boards can be connected to this interface. A variety of different adapters are available for all FX lines (except the FX2NC). These adapters extend the capabilities of the controllers with additional functions or communications interfaces. The adapter boards are plugged directly into the slot.
Connection for programming units	This connection can be used for connecting the FX-20P-E hand-held programming unit or an external PC or notebook with a programming software package (e.g. GX Developer/FX).
EEPROM	Read/write memory in which the PLC program can be stored and read with the programming software. This solid-state memory retains its contents without power, even in the event of a power failure, and does not need a battery.
Memory cassette slot	Slot for optional memory cassettes. Inserting a memory cassette disables the controller's internal memory – the controller will then only execute the program stored in the cassette.
Extension bus	Both additional I/O expansion modules and special function modules that add additional capabilities to the PLC system can be connected here. See Chapter 6 for an overview of the available modules.
Analog potentiometers	The analog potentiometers are used for setting analog setpoint values. The setting can be polled by the PLC program and used for timers, pulse outputs and other functions (see Section 4.6.1).
Service power supply	The service power supply (not for FX2NC) provides a regulated 24V DC power supply source for the input signals and the sensors. The capacity of this power supply depends on the controller model (e.g. FX1S and FX1N: 400mA; FX2N-16M□-□□ through FX2N-32M□-□□: 250 mA, FX2N-48M□-□□ through FX2N-64M□-□□: 460 mA)
Digital inputs	The digital inputs are used for inputting control signals from the connected switches, buttons or sensors. These inputs can read the values ON (power signal on) and OFF (no power signal).
Digital outputs	You can connect a variety of different actuators and other devices to these outputs, depending on the nature of your application and the output type.
LEDs for indicating the input status	These LEDs show which inputs are currently connected to a power signal, i.e. a defined voltage. When a signal is applied to an input the corresponding LED lights up, indicating that the state of the input is ON.
LEDs for indicating the output status	These LEDs show the current ON/OFF states of the digital outputs. These outputs can switch a variety of different voltages and currents depending on the model and output type.
LEDs for indicating the operating status	The LEDs RUN, POWER and ERROR show the current status of the controller. POWER shows that the power is switched on, RUN lights up when the PLC program is being executed and ERROR lights up when an error or malfunction is registered.
Memory battery	The battery protects the contents of the MELSEC PLC's volatile RAM memory in the event of a power failure (FX2N, FX2NC and FX3U only). It protects the latched ranges for timers, counters and relays. In addition to this it also provides power for the integrated real-time clock when the PLC's power supply is switched off.
RUN/STOP switch	MELSEC PLCs have two operating modes, RUN and STOP. The RUN/STOP switch allows you to switch between these two modes manually. In RUN mode the PLC executes the program stored in its memory. In STOP mode program execution is stopped and it is possible to program the controller.

3 An Introduction to Programming

A program consists of a sequence of program instructions. These instructions determine the functionality of the PLC and they are processed sequentially, in the order in which they were entered by the programmer. To create a PLC program you thus need to analyse the process to be controlled and break it up into steps that can be represented by instructions. A program instruction, represented by a line or “rung” in ladder diagram format, is the smallest unit of a PLC application program.

3.1 Structure of a Program Instruction

A program instruction consists of the instruction itself (sometimes referred to as a command) and one or more (in the case of applied instructions) operands, which in a PLC are references to devices. Some instructions are entered on their own without specifying any operands – these are the instructions that control program execution in the PLC.

Every instruction you enter is automatically assigned a step number that uniquely identifies its position in the program. This is important because it is quite possible to enter the same instruction referring to the same device in several places in the program.

The illustrations below show how program instructions are represented in the Ladder Diagram (LD, left) and Instruction List (IL, right) programming language formats:



The instruction describes **what** is to be done, i.e. the function you want the controller to perform. The operand or device is what you want to perform the function **on**. Its designation consists of two parts, the device name and the device address:



Examples of devices:

Device name	Type	Function
X	Input	Input terminal on the PLC (e.g. connected to a switch)
Y	Output	Output terminal on the PLC (e.g. for a contactor or lamp)
M	Relay	A buffer memory in the PLC that can have two states, ON or OFF
T	Timer	A “time relay” that can be used to program timed functions
C	Counter	A counter
D	Data register	Data storage in the PLC in which you can store things like measured values and the results of calculations.

See Chapter 4 for a detailed description of the available devices.

The specific device is identified by its address. For example, since every controller has multiple inputs you need to specify both the device name and the address in order to read a specific input.

3.2 Bits, Bytes and Words

As in all digital technology, the smallest unit of information in a PLC is a “bit”. A bit can only have two states: “0” (OFF or FALSE) and “1” (ON or TRUE). PLCs have a number of so-called **bit devices** that can only have two states, including inputs, outputs and relays.

The next larger information units are the “byte”, which consists of 8 bits, and the “word”, which consists of two bytes. In the PLCs of the MELSEC FX families the data registers are “word devices”, which means that they can store 16-bit values.

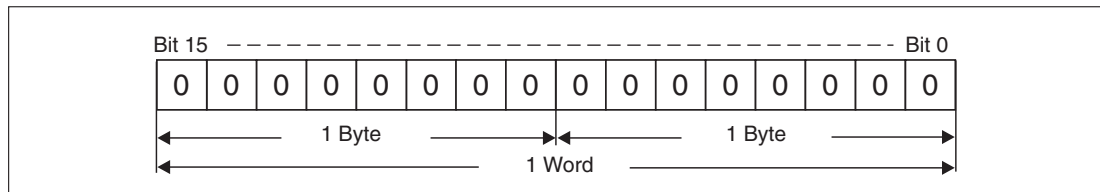

Since a data register is 16 bits wide it can store signed values between -32,768 and +32,767 (see Chapter 3.3). When larger values need to be stored two words are combined to form a 32-bit long word, which can store signed values between -2,147,483,648 and +2,147,483,647. Counters make use of this capability, for example.

3.3 Number Systems

The PLCs of the MELSEC FX family use several different number systems for inputting and displaying values and for specifying device addresses.

Decimal numbers

The decimal number system is the system we use most commonly in everyday life. It is a “positional base 10” system, in which each digit (position) in a numeral is ten times the value of the digit to its right. After the count reaches 9 in each position the count in the current position is returned to 0 and the next position is incremented by 1 to indicate the next decade (9 → 10, 99 → 100, 199 → 1,000 etc).

- Base: 10
- Digits: 0, 1, 2, 3, 4, 5, 6, 7, 8, 9

In the MELSEC FX family of PLCs decimal numbers are used for entering constants and the setpoint values for timers and counters. Device addresses are also entered in decimal format, with the exception of the addresses of inputs and outputs.

Binary numbers

Like all computers a PLC can only really distinguish between two states, ON/OFF or 0/1. These “binary states” are stored in individual bits. When numbers need to be entered or displayed in other formats the programming software automatically converts the binary numbers into the other number systems.

- Base: 2
- Digits: 0 and 1

When binary numbers are stored in a word (see above) the value of each digit (position) in the word is one power of 2 higher than that of the digit to its right. The principle is exactly the same as in decimal representation, but with increments of 2 instead of 10 (see graphic):

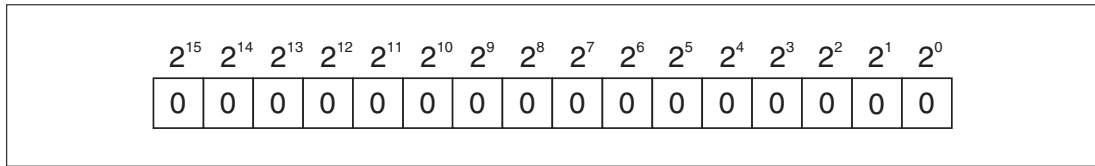

Base 2 Notation	Decimal Value	Base 2 Notation	Decimal Value
2^0	1	2^8	256
2^1	2	2^9	512
2^2	4	2^{10}	1024
2^3	8	2^{11}	2048
2^4	16	2^{12}	4096
2^5	32	2^{13}	8192
2^6	64	2^{14}	16384
2^7	128	2^{15}	32768*

* In binary values bit 15 is used to represent the sign (bit 15=0: positive value, bit 15=1: negative value)

To convert a binary value to a decimal value you just have to multiply each digit with a value of 1 by its corresponding power of 2 and calculate the sum of the results.

Example ▾

00000010 00011001 (binary)
 00000010 00011001 (binary) = $1 \times 2^9 + 1 \times 2^4 + 1 \times 2^3 + 1 \times 2^0$
 00000010 00011001 (binary) = $512 + 16 + 8 + 1$
 00000010 00011001 (binary) = 537 (decimal)

Hexadecimal numbers

Hexadecimal numbers are easier to handle than binary and it is very easy to convert binary numbers to hexadecimal. This is why hexadecimal numbers are used so often in digital technology and programmable logic controllers. In the controllers of the MELSEC FX family hexadecimal numbers are used for the representation of constants. In the programming manual and other manuals hexadecimal numbers are always identified with an H after the number to avoid confusion with decimal numbers (e.g. 12345H).

- Base: 16
- Digits: 0, 1, 2, 3, 4, 5, 6, 7, 8, 9, A, B, C, D, E, F (the letters A, B, C, D, E and F represent the decimal values 10, 11, 12, 13, 14 and 15)

The hexadecimal system works in the same way as the decimal system – you just count to FH (15) instead of to 9 before resetting to 0 and incrementing the next digit (FH → 10H, 1FH → 20H, 2FH → 30H, FFH → 100H etc). The value of digit is a power of 16, rather than a power of 10:

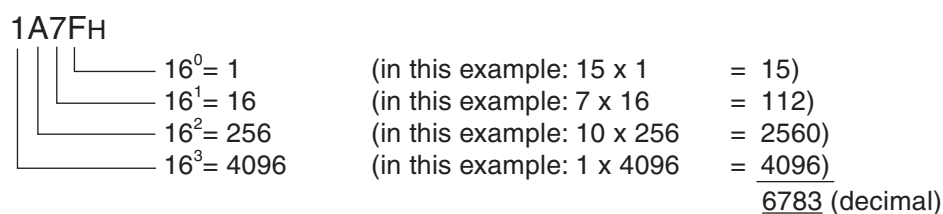

The following example illustrates why it is so easy to convert binary values hexadecimal values:

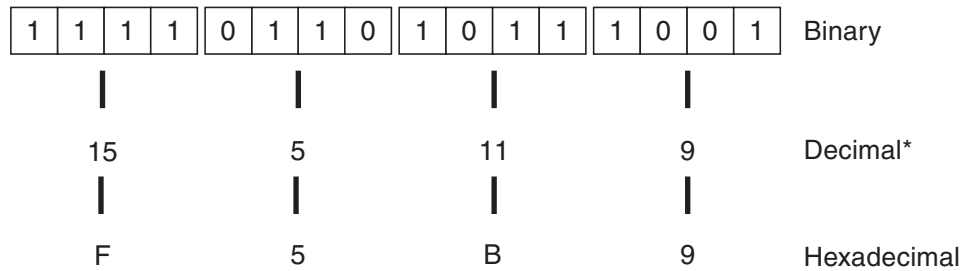

* Converting the 4-bit blocks to decimal values does not directly produce a value that corresponds to the complete 16-bit binary value! In contrast, the binary value can be converted directly to hexadecimal notation with exactly the same value as the binary value.

Octal numbers

Inputs X8 and X9 and outputs Y8 and Y9 do not exist on the base units of the MELSEC FX family. This is because the inputs and outputs of MELSEC PLCs are numbered using the octal number system, in which the digits 8 and 9 don't exist. Here, the current digit is reset to 0 and the digit in the next position is incremented after the count reaches 7 (0 – 7, 10 – 17, 70 – 77, 100 – 107 etc).

- Base: 8
- Digits: 0, 1, 2, 3, 4, 5, 6, 7

Summary

The following table provides an overview of the four different number systems:

Decimal notation	Octal notation	Hexadecimal notation	Binary notation
0	0	0	0000 0000 0000 0000
1	1	1	0000 0000 0000 0001
2	2	2	0000 0000 0000 0010
3	3	3	0000 0000 0000 0011
4	4	4	0000 0000 0000 0100
5	5	5	0000 0000 0000 0101
6	6	6	0000 0000 0000 0110
7	7	7	0000 0000 0000 0111
8	10	8	0000 0000 0000 1000
9	11	9	0000 0000 0000 1001
10	12	A	0000 0000 0000 1010
11	13	B	0000 0000 0000 1011
12	14	C	0000 0000 0000 1100
13	15	D	0000 0000 0000 1101
14	16	E	0000 0000 0000 1110
15	17	F	0000 0000 0000 1111
16	20	10	0000 0000 0001 0000
:	:	:	:
99	143	63	0000 0000 0110 0011
:	:	:	:

3.4 The Basic Instruction Set

The instructions of the PLCs of the MELSEC FX family can be divided into two basic categories, basic instructions and applied instructions, which are sometimes referred to as “application instructions”.

The functions performed by the basic instructions are comparable to the functions achieved by the physical wiring of a hard-wired controller. All controllers of the MELSEC FX family support the instructions in the basic instruction set, but the applied instructions supported vary from model to model (see Chapter 5).

Basic instruction set quick reference

Instruction	Function	Description	Reference
LD	Load	Initial logic operation, polls for signal state “1” (normally open)	Chapter 3.4.1
LDI	Load invers	Initial logic operation, polls for signal state “0” (normally closed)	
OUT	Output instruction	Assigns the result of a logic operation to a device	Chapter 3.4.2
AND	Logical AND	Logical AND operation, polls for signal state “1”	Chapter 3.4.4
ANI	AND NOT	Logical AND NOT operation, polls for signal state “0”	
OR	Logical OR	Logical OR operation, polls for signal state “1”	Chapter 3.4.5
ORI	OR NOT	Logical OR NOT operation, polls for signal state “0”	
ANB	AND Block	Connects a parallel branch circuit block to the preceding parallel block, in series.	Chapter 3.4.6
ORB	OR Block	Connects a serial block of circuits to the preceding serial block, in parallel.	
LDP	Pulse signal instructions	Load Pulse, load on detection of rising edge of device signal pulse	Chapter 3.4.7
LDF		Load Falling Pulse, load on falling device signal pulse	
ANDP		AND Pulse, logical AND on rising device signal pulse	
ANDF		AND Falling Pulse, logical AND on falling device signal pulse	
ORP		OR Pulse, logical OR on rising device signal pulse	
ORF		OR Falling Pulse, logical OR on falling device signal pulse	
SET	Set device	Assigns a signal state that is retained even if after input condition is no longer true	Chapter 3.4.8
RST	Reset device		
MPS	Store, read and delete intermediate operation results	Memory Point Store, store an operation result in the stack	Chapter 3.4.9
MRD		Memory Read, read a stored operation result from the stack	
MPP		Memory POP, read a stored operation result and delete it from the stack	
PLS	Pulse instructions	Pulse, sets a device for one operation cycle on the rising pulse of the input condition (input turns ON)	Chapter 3.4.10
PLF		Pulse Falling, sets a device* for one operation cycle on the falling pulse of the input condition (input turns OFF)	
MC	Master Control	Instructions for activating or deactivating the execution of defined parts of the program	Chapter 3.4.11
MCR	Master Control Reset		
INV	Invert	Inverts the result of an operation	Chapter 3.4.12

3.4.1 Starting logic operations

Instruction	Function	Symbol	GX Developer FX
LD	Load instruction, starts a logic operation and polls the specified device for signal state "1"		
LDI	Load instruction, starts a logic operation and polls the specified device for signal state "0"		

A circuit in a program always begins with an LD- or LDI instruction. These instructions can be performed on inputs, relays, timers and counters.

For examples of using these instructions see the description of the OUT instruction in the next section.

3.4.2 Outputting the result of a logic operation

Instruction	Function	Symbol	GX Developer FX
OUT	Output instruction, assigns the result of an operation to a device		

The OUT instruction can be used to terminate a circuit. You can also program circuits that use multiple OUT instructions as their result. This is not necessarily the end of the program, however. The device set with the result of the operation using OUT can then be used as an input signal state in subsequent steps of the program.

Example (LD and OUT instructions)

Ladder Diagram

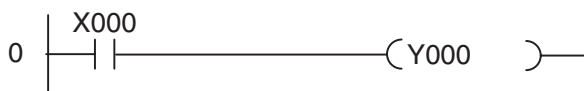

Instruction List

```

0 LD X000
1 OUT Y000
    
```

These two instructions result in the following signal sequence:

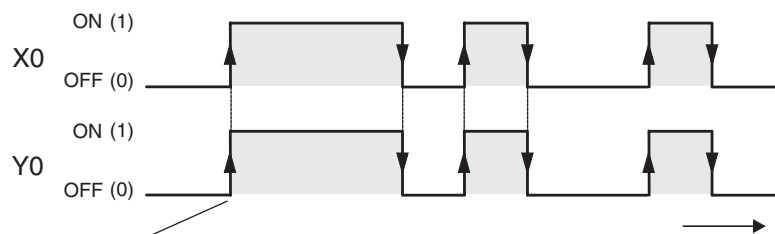

The condition of the LD instruction (poll for signal state "1") is true so the result of the operation is also true ("1") and the output is set.

Example (LDI and OUT instructions)

Ladder Diagram

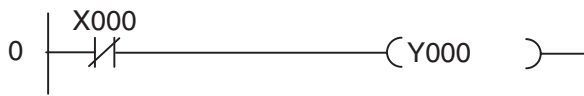

Instruction List

```
0 LDI X000
1 OUT Y000
```

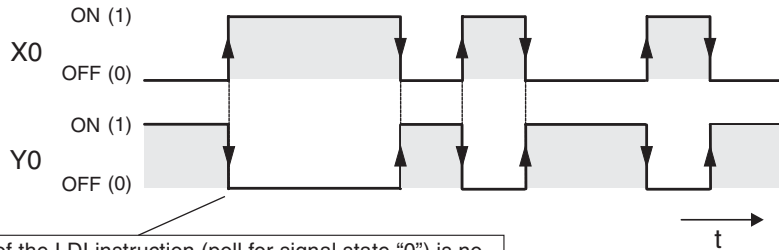

The condition of the LDI instruction (poll for signal state "0") is no longer true so the output is reset.

Double assignment of relays or outputs

Never assign the result of an operation to the same device in more than one place in the program!

The program is executed sequentially from top to bottom, so in this example the second assignment of M10 would simply overwrite the result of the first assignment.

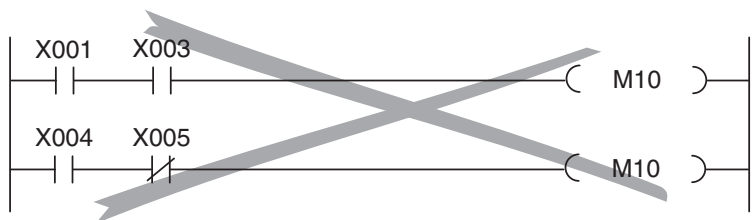



You can solve this problem with modification shown on the right. This takes all the required input conditions into account and sets the result correctly.



3.4.3 Using switches and sensors

Before we continue with the description of the rest of the instructions we should first describe how signals from switches, sensors and so on can be used in your programs.

PLC programs need to be able respond to signals from switches, buttons and sensors to perform the correct functions. It is important to understand that program instructions can only poll the binary signal state of the specified input – irrespective of the type of input and how it is controlled.

	Make contact	When a make contact is operated the input is set (ON, signal state "1")
	Break contact	When a break contact is operated the input is reset (OFF, signal state "0")



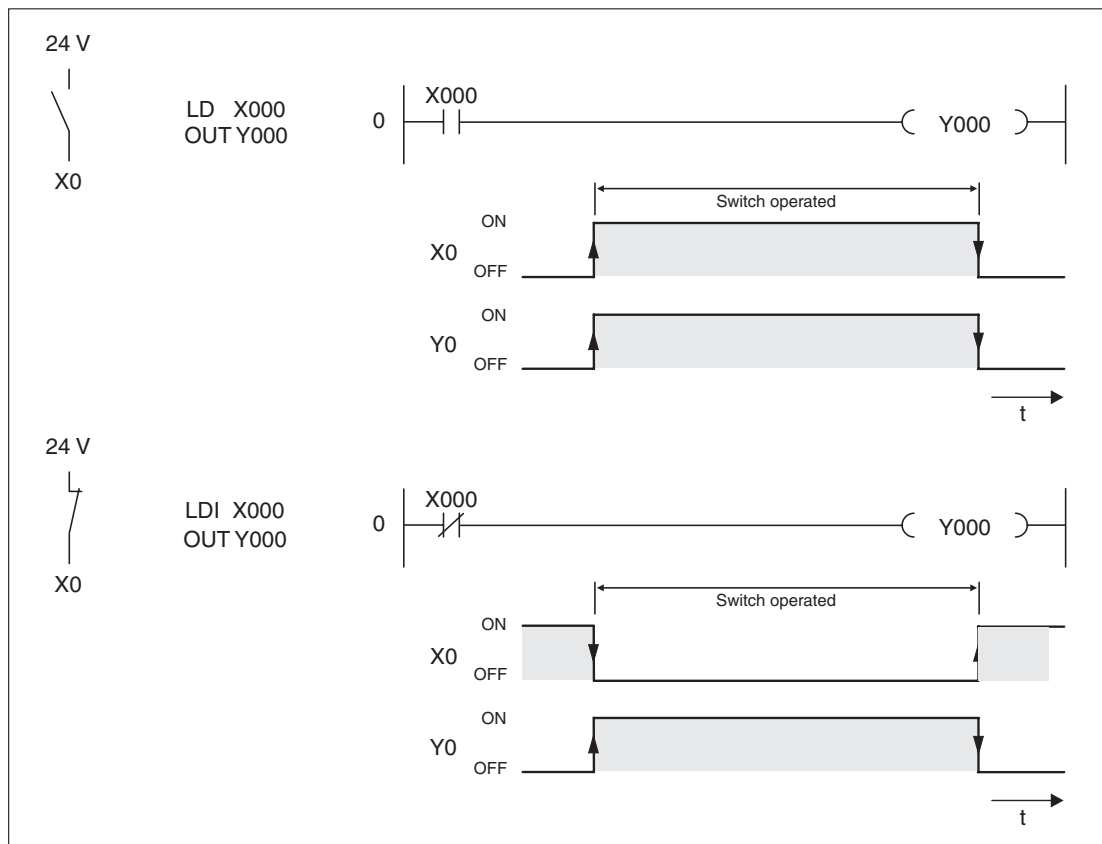

As you can imagine, this means that when you are writing your program you need to be aware whether the element connected to the input of your PLC is a make or a break device. An input connected to a make device must be treated differently to an input connected to a break device. The following example illustrates this.

Usually, switches with make contacts are used. Sometimes, however, break contacts are used for safety reasons – for example for switching off drives (see section 3.5).

The illustration below shows two program sequences in which the result is exactly the same, even though different switch types are used: When the switch is operated the output is set (switched on).



3.4.4 AND operations

Instruction	Function	Symbol	GX Developer FX
AND	Logical AND (AND operation with poll for signal state "1" or ON)		
ANI	Logical AND NOT (AND operation with poll for signal state "0" or OFF)		

An AND operation is logically the same as a serial connection of two or more switches in an electrical circuit. Current will only flow if all the switches are closed. If one or more of the switches are open no current flows – the AND condition is false.

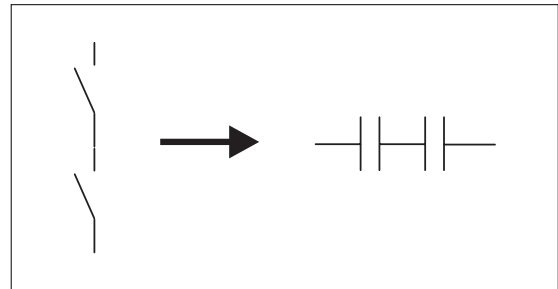

Note that the programming software uses the same icons and function keys for the AND and ANI instructions as for the LD and LDI instructions. When you program in Ladder Diagram format the software automatically assigns the correct instructions on the basis of the insertion position.

When you program in Instruction List format remember that you can't use the AND and ANI instructions at the beginning of circuit (a program line in ladder diagram format)! Circuits must begin with an LD or LDI instruction (see Chapter 3.4.1).

Example of an AND instruction

Ladder Diagram

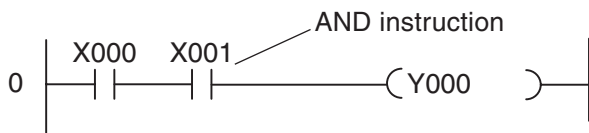

Instruction List

```

0 LD X000
1 AND X001
2 OUT Y000
    
```

In the example output Y0 is only switched on when inputs X0 **and** X1 are **both** on:

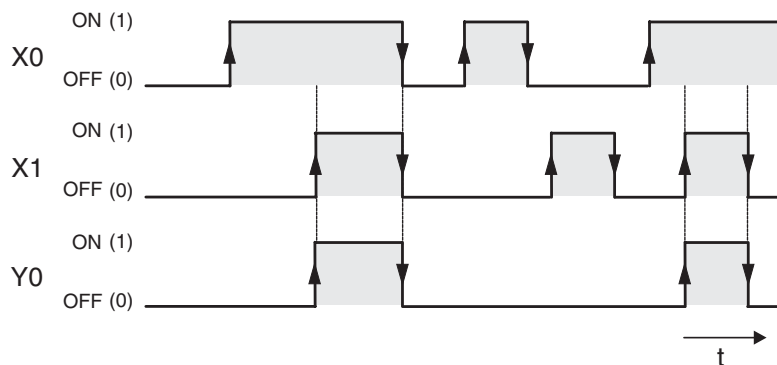

Example of an ANI instruction

Ladder Diagram

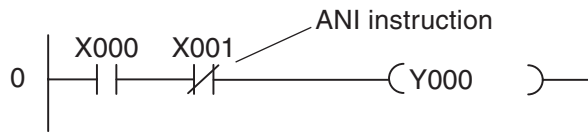

Instruction List

0	LD	X000
1	ANI	X001
2	OUT	Y000

In the example output Y0 is only switched on when input X0 is on **and** input X1 is off:

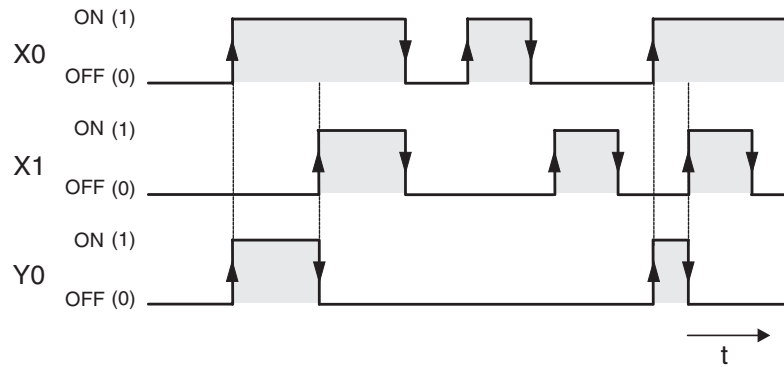

3.4.5 OR operations

Instruction	Function	Symbol	GX Developer FX
OR	Logical OR (OR operation with poll for signal state "1" or ON)		
ORI	Logical OR NOT (OR operation with poll for signal state "0" or OFF)		

An OR operation is logically the same as the parallel connection of multiple switches in an electrical circuit. As soon as any of the switches is closed current will flow. Current will only stop flowing when **all** the switches are open.

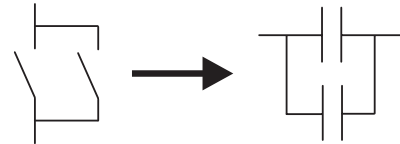

Example of an OR instruction

Ladder Diagram

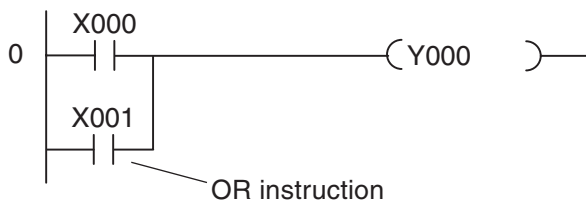

Instruction List

```

0 LD X000
1 OR X001
2 OUT Y000
    
```

In the example output Y0 is switched on when **either** input X0 **or** input X1 is on:

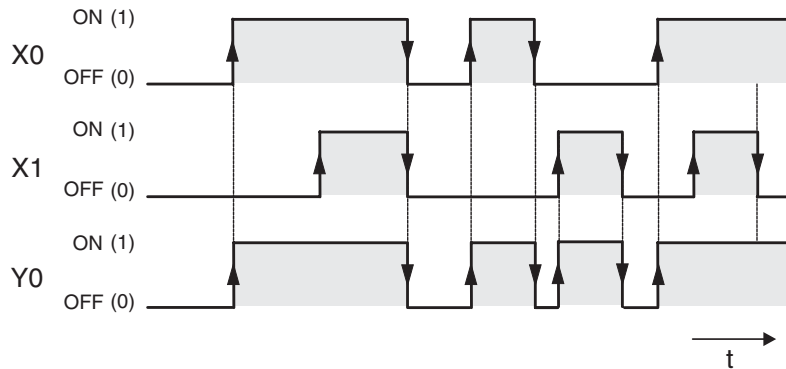

Example of an ORI instruction

Ladder Diagram

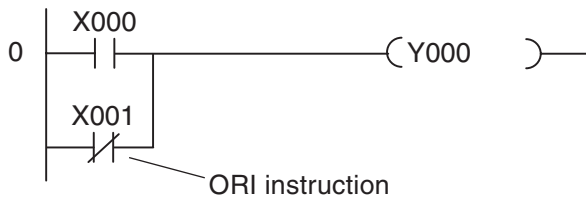

Instruction List

0	LD	X000
1	ORI	X001
2	OUT	Y000

In the example output Y0 is switched on when **either** input X0 is on **or** input X1 is off:

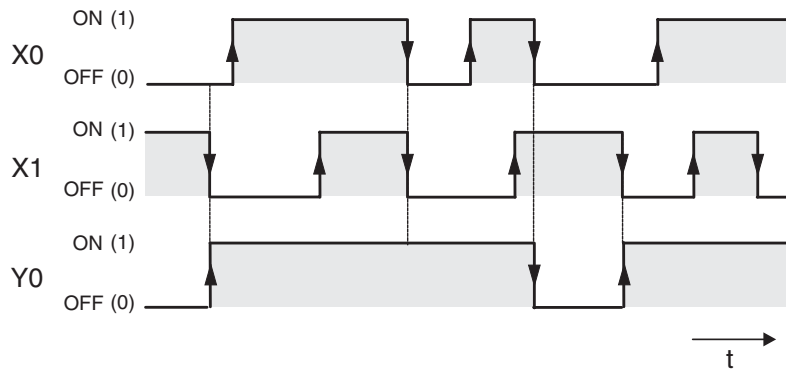

3.4.6 Instructions for connecting operation blocks

Instruction	Function	Symbol	GX Developer FX
ANB	AND Block (serial connection of blocks of parallel operations/circuits)	—	
ORB	OR Block (parallel connection of blocks of serial operations/circuits)		

Although ANB- and ORB are PLC instructions they are only displayed and entered as connecting lines in the Ladder Diagram display. They are only shown as instructions in Instruction List format, where you must enter them with their acronyms ANB and ORB.

Both instructions are entered without devices and can be used as often as you like in a program. However, the maximum number of LD and LDI instructions is restricted to 8, which effectively also limits the number of ORB or ANB instructions you can use before an output instruction to 8 as well.

Example of an ANB instruction

Ladder Diagram



Instruction List

- 0 LD X000
- 1 ORI M2 ← 1st parallel connection (OR operation)
- 2 LDI X001
- 3 OR M10 ← 2nd parallel connection (OR operation)
- 4 ANB ← ANB instruction connecting both OR operations
- 5 OUT Y007

In this example output Y07 is switched on if input X00 is “1”, **or** if relay M2 is “0” **and** input X01 is “0”, **or** if relay M10 is “1”.

Example of an ORB instruction

Ladder Diagram

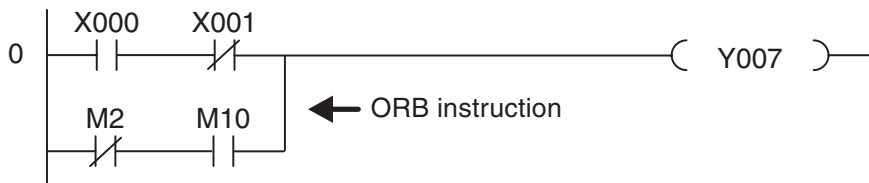

Instruction List

- 0 LD X000
- 1 ANI X001 ← 1st serial connection (AND operation)
- 2 LDI M2
- 3 AND M10 ← 2nd serial connection (AND operation)
- 4 ORB ← ORB instruction connecting both AND operations
- 5 OUT Y007

In this example output Y07 is switched on if input X00 is “1” **and** input X01 is “0”, **or** if relay M2 is “0” **and** relay M10 is “1”.

3.4.7 Pulse-triggered execution of operations

Instruction	Function	Symbol	GX Developer FX
LDP	Load Pulse, loads on the rising edge of the device's signal		
LDF	Load Falling Pulse, loads on the falling edge of the device's signal		
ANDP	AND Pulse, logical AND operation on the rising edge of the device's signal		
ANDF	AND Falling Pulse, logical AND operation on the falling edge of the device's signal		
ORP	OR Pulse, logical OR operation on the rising edge of the device's signal		
ORF	OR Falling Pulse, logical OR operation on the falling edge of the device's signal		

In PLC programs you will often need to detect and respond to the rising or falling edge of a bit device's switching signal. A rising edge indicates a switch of the device value from "0" to "1", a falling edge indicates a switch from "1" to "0".

During program execution operations that respond to rising and falling pulses only deliver a value of "1" when the signal state of the referenced device changes.

When do you need to use this? For example, suppose you have a conveyor belt with a sensor switch that activates to increment a counter every time a package passes it on the belt. If you don't use a pulse-triggered function you will get incorrect results because the counter will increment by 1 in every program cycle in which the switch registers as set. If you only register the rising pulse of the switch signal the counter will be incremented correctly, increasing by 1 for each package.

Note

| Most applied instructions can also be executed by pulse signals. For details see chapter . 5).

Evaluating a rising signal pulse

Ladder Diagram

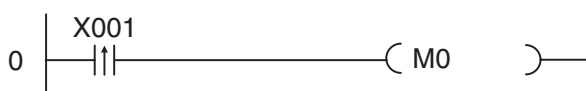

Instruction List

```
0 LDP X001
1 OUT M0
```

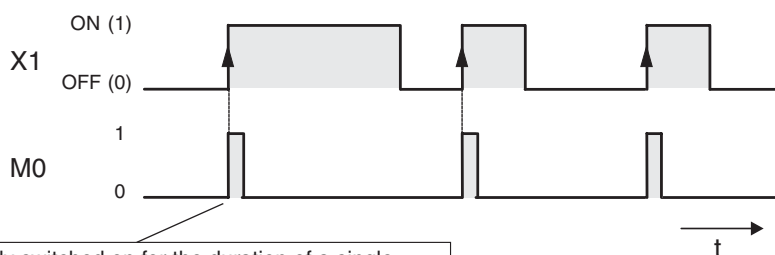

Relay M0 is only switched on for the duration of a single program cycle

Evaluating a falling signal pulse

Ladder Diagram

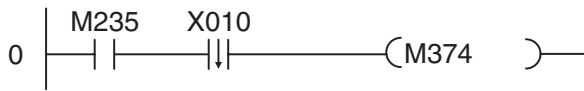

Instruction List

```

0 LD M235
1 ANDF X010
2 OUT M374
    
```

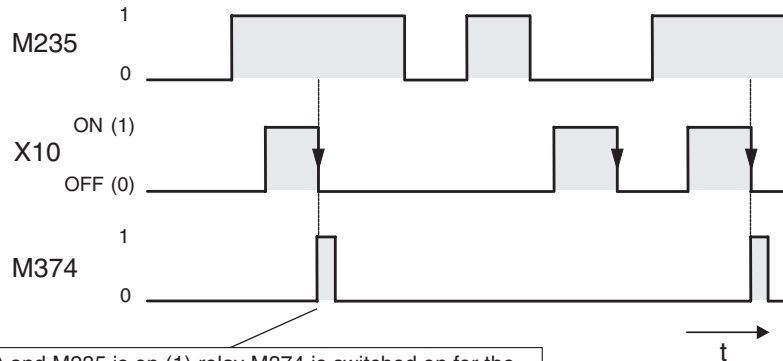

If X10 is off (0) and M235 is on (1) relay M374 is switched on for the duration of a single program cycle.

With the exception of the pulse trigger characteristic the functions of the LDP, LDF, ANDP, ANDF, ORP and ORF instructions are identical to those of the LD, AND and OR instructions. This means that you can use pulse-trigger operations in your programs in exactly the same way as the conventional versions.

3.4.8 Setting and resetting devices

Instruction	Function	Symbol	GX Developer FX
SET	Set a device ^① , (assign signal state "1")		
RST	Reset a device ^② , (assign signal state "0")		

- ① The SET instruction can be used to set outputs (Y), relays (M) and state relays (S).
- ② The RST instruction can be used to reset outputs (Y), relays (M), state relays (S), timers (T), counters (C) and registers (D, V, Z).

The signal state of an OUT instruction will normally only remain "1" as long as the result of the operation connected to the OUT instruction evaluates to "1". For example, if you connect a pushbutton to an input and a lamp to the corresponding output and connect them with an LD and an OUT instruction the lamp will only remain on while the button remains pressed.

The SET instruction can be used to use a brief switching pulse to switch an output or relay on (set) and leave them on. The device will then remain on until you switch it off (reset) with a RST instruction. This enables you to implement latched functions or switch drives on and off with pushbuttons. (Outputs are generally also switched off when the PLC is stopped or the power supply is turned off. However, some relays also retain their last signal state under these conditions – for example a set relay would then remain set.)

To enter a SET or RST instruction in Ladder Diagram format just click on the icon shown in the table above in GX Developer, or press the F8 key. Then enter the instruction and the name of the device you want to set or reset, for example *SET Y1*.

Ladder Diagram

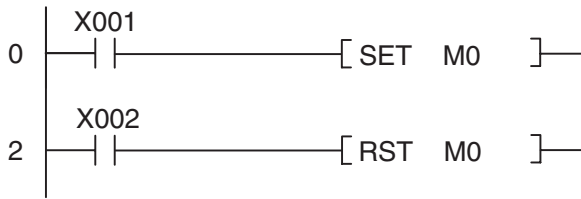

Instruction List

0	LD	X001
1	SET	M0
2	LD	X002
3	RST	M0

If the set and reset instructions for the same device both evaluate to "1" the last operation performed has priority. In this example that is the RST instruction, and so M0 remains off.

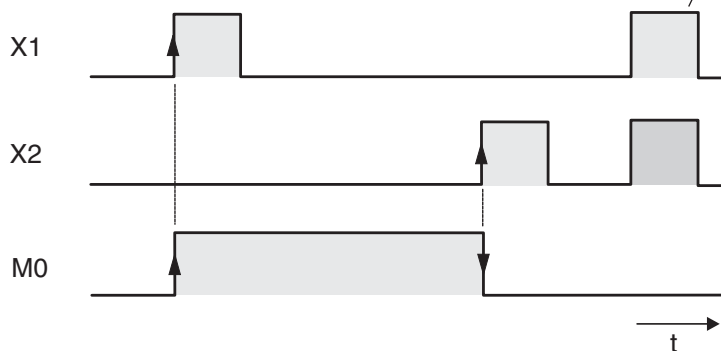

This example is a program for controlling a pump to fill a container. The pump is controlled manually with two pushbuttons, ON and OFF. For safety reasons a break contact is used for the OFF function. When the container is full a level sensor automatically switches the pump off.

Ladder Diagram

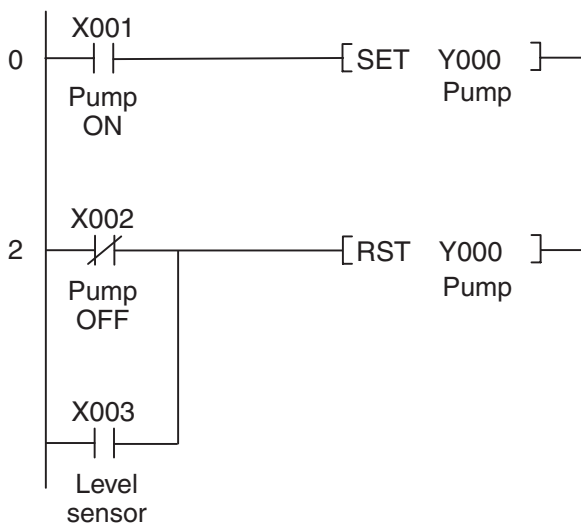

Instruction List

0	LD	X001
1	SET	Y000
2	LDI	X002
3	OR	X003
4	RST	Y000

3.4.9 Storing, reading and deleting operation results

Instruction	Function	Symbol	GX Developer FX
MPS	Memory Point Store, stores the result of an operation	—	—
MRD	Memory Read, reads a stored operation result	—	—
MPP	Memory POP, reads a stored operation result and deletes it	—	—

The MPS, MRD and MPP instructions are used to store the results of operations and intermediate values in a memory called the “stack”, and to read and delete the stored results. These instructions make it possible to program multi-level operations, which makes programs easier to read and manage.

When you enter programs in Ladder Diagram format these instructions are inserted automatically by the programming software. The MPS, MRD and MPP instructions are only actually shown when you display your program in Instruction List format, and they must also be entered manually when you program in this format.

Ladder Diagram

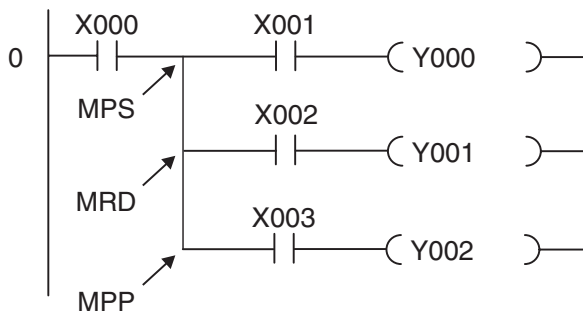

Instruction List

0	LD	X000
1	MPS	
2	AND	X001
3	OUT	Y000
4	MRD	
5	AND	X002
6	OUT	Y001
7	MPP	
8	AND	X003
9	OUT	Y002

To make the advantage of these instructions clearer the example below shows the same program sequence programmed without MPS, MRD and MPP:

Ladder Diagram

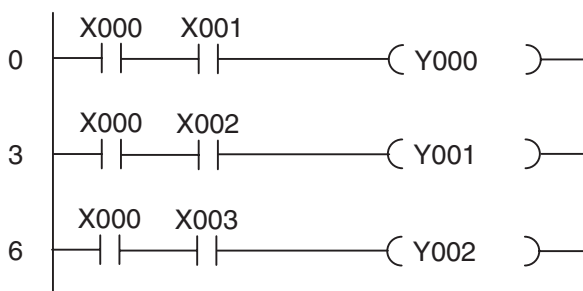

Instruction List

0	LD	X000
1	AND	X001
2	OUT	Y000
3	LD	X000
4	AND	X002
5	OUT	Y001
6	LD	X000
7	AND	X003
8	OUT	Y002

When you use this approach you must program the devices (X0 in this example) repeatedly. This results in more programming work, which can make quite a difference in longer programs and complex circuit constructions.

In the last output instruction you must use MPP instead of MRD to delete the stack. You can use multiple MPS instructions to create operations with up to 11 levels. For more examples of how to use the MPS, MRD and MPP instructions see the Programming Manual for the FX Family.

3.4.10 Generating pulses

Instruction	Function	Symbol	GX Developer FX
PLS	Pulse, sets an device* for the duration of a single program cycle on the rising edge of the switching pulse of the input condition / device		
PLF	Pulse Falling, sets a device* for the duration of a single program cycle on the falling edge of the switching pulse of the input condition / device		

* PLC and PLF instructions can be used to set outputs (Y) and relays (M).

These instructions effectively convert a static signal into a brief pulse, the duration of which depends on the length of the program cycle. If you use PLS instead of an OUT instruction the signal state of the specified device will only be set to “1” for a single program cycle, specifically during the cycle in which the signal state of the device before the PLS instruction in the circuit switches from “0” to “1” (rising edge pulse).

The PLF instruction responds to a falling edge pulse and sets the specified device to “1” for a single program cycle, during the cycle in which the signal state of the device before the PLF instruction in the circuit switches from “1” to “0” (falling edge pulse).

To enter a PLS or PLF instruction in Ladder Diagram format click in the GX Developer toolbar on the tool icon shown above or press **F8**. Then enter the instruction and the corresponding device to be set in the dialog, e.g. PLS Y2.

Ladder Diagram

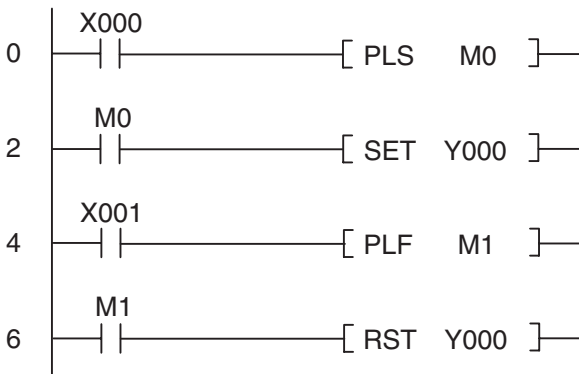

Instruction List

- 0 LD X000
- 1 PLS M0
- 2 LD M0
- 3 SET Y000
- 4 LD X001
- 5 PLF M1
- 6 LD M1
- 7 RST Y000

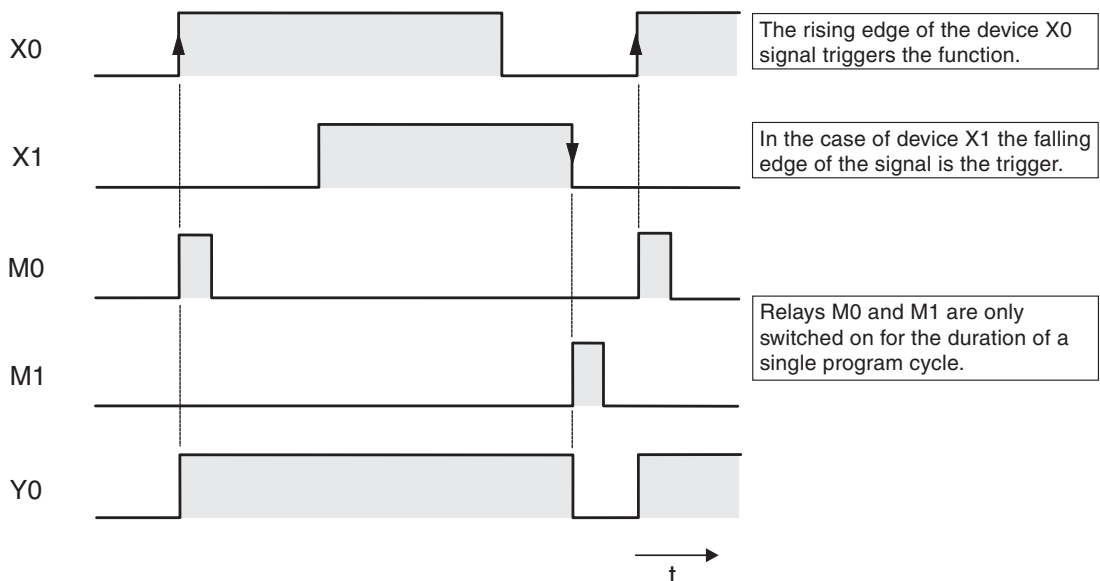

3.4.11 Master control function (MC and MCR instructions)

Instruction	Function	Symbol	GX Developer FX
MC	Master Control, sets a master control condition, marking the beginning of a program block ^①	MC n □	
MCR	Master Control Reset, resets a master control condition, marking the end of a program block ^②	MCR n	

- ① The MC instruction can be used on outputs (Y) and relays (M). n: N0 through N7
- ② n: N0 through N7

The Master Control Set (MC) and Reset (MCR) instructions can be used to set conditions on the basis of which individual program blocks can be activated or deactivated. In Ladder Diagram format a Master Control instruction functions like a switch in the left-hand bus bar that must be closed for the following program block to be executed.

Ladder Diagram

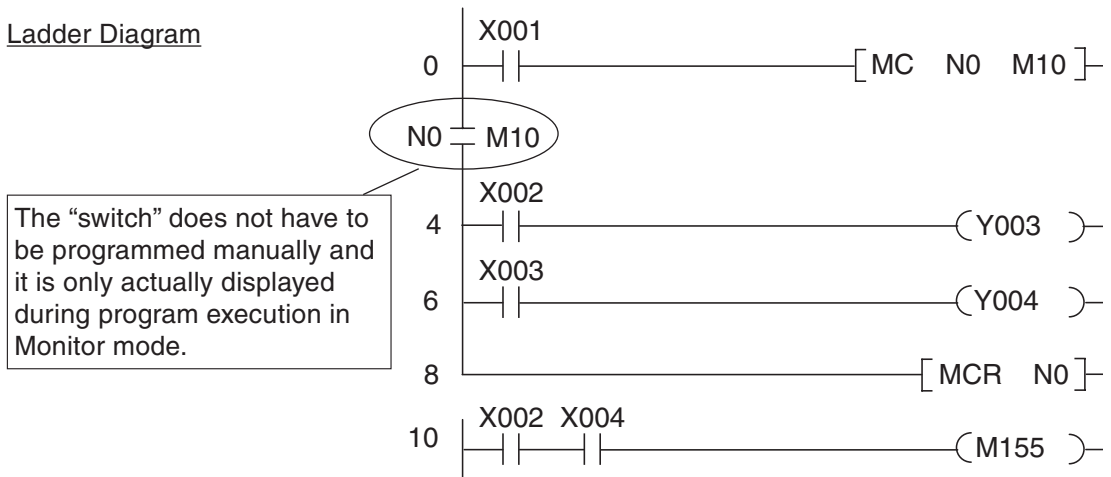

Instruction List

0	LD	X001	
1	MC	N0	M10
4	LD	X002	
5	OUT	Y003	
6	LD	X003	
7	OUT	Y004	
8	MCR	N0	
10	LD	X002	
11	AND	X004	
12	OUT	M155	

In the example above the program lines between the MC and MCR instructions are only executed when input X001 is on.

The section of the program to be executed can be specified with the nesting address N0 through N7, which allows you to enter multiple MC instructions before the closing MCR instruction. (See the FX Programming Manual for an example of nesting.) Addressing a Y or M device specifies a make contact. This contact activates the program section when the input condition for the MC instruction evaluates true.

If the input condition of the MC instruction evaluates false the states of the devices between the MC and MCR instructions change as follows:

- Latched timers and counters and devices that are controlled with SET and RST instructions retain their current state.
- Unlatched timers and devices that are controlled with OUT instructions are reset.

(See chapter 4 for details on these timers and counters.)

3.4.12 Inversion of an Operation Result

Instruction	Function	Symbol	GX Developer FX
INV	Invert, reverses the result of an operation		

An INV instruction inverts the operation result up to just before the INV instruction, and does not require device number specification.

- If the result of an operation is "1", it becomes "0" after execution of the INV instruction.
- If the result of an operation is "0", it becomes "1" after execution of the INV instruction.

Ladder Diagram

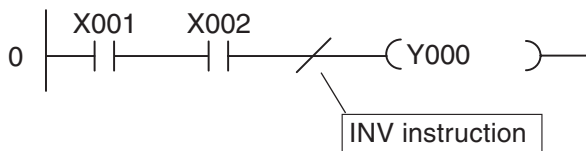

Instruction List

```

0 LD X001
1 AND X002
2 INV
3 OUT Y000
    
```

The above example produces the following signal sequence:

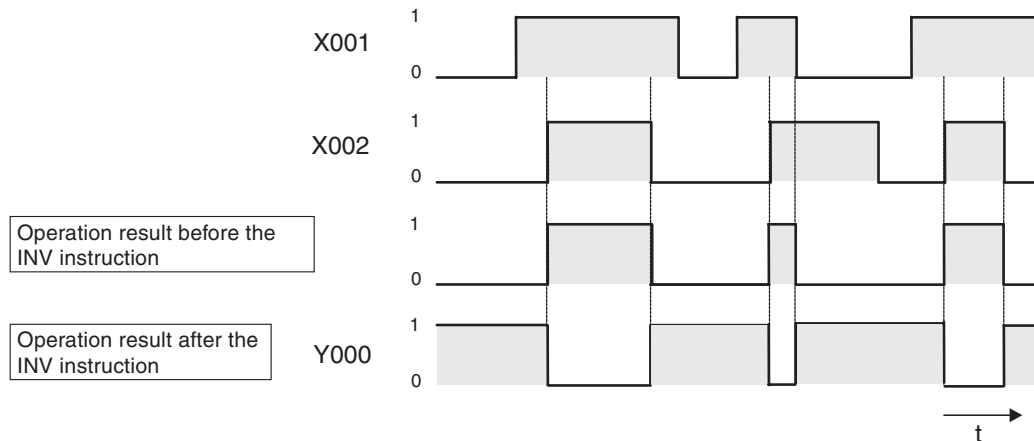

The INV instruction can be used when you need to invert the result of a complex operation. It can be used in the same position as the AND and ANI instructions.

The INV instruction cannot be used at the beginning of an operation (circuit) like an LD, LDI, LDP or LDF instruction.

3.5 Safety First!

PLCs have many advantages over hard-wired controllers. However, when it comes to safety it is important to understand that you cannot trust a PLC blindly.

Emergency OFF devices

It is essential to ensure that errors in the control system or program cannot cause hazards for staff or machines. Emergency OFF devices must remain fully functional even when the PLC is not working properly – for example to switch off the power to the PLC outputs if necessary.

Never implement an Emergency OFF switch solely as an input that is processed by the PLC, with the PLC program activating the shutdown. This would be much too risky.

Safety precautions for cable breaks

You must also take steps to ensure safety in the event that the transmission of signals from the switches to the PLC are interrupted by cable breaks. When switching equipment on and off via the PLC always use switches or pushbuttons with make contacts for switching on and with break contacts for switching off.

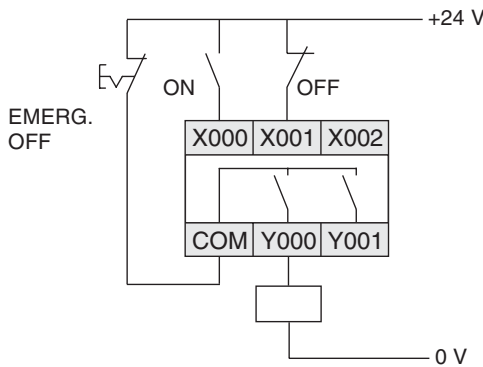

In this example the contactor for a drive system can also be switched off manually with an Emergency OFF switch.

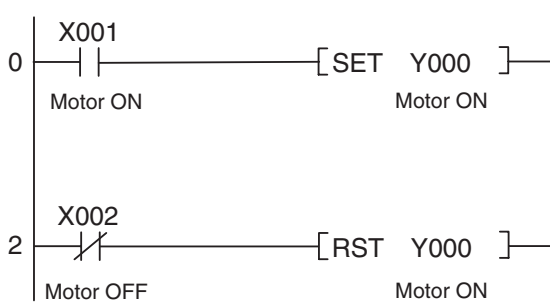

In the program for this installation the make contact of the ON switch is polled with an LD instruction, the break contact of the OFF switch with an LDI instruction. The output, and thus also the drive, is switched off when the input X002 has a signal state of “0”. This is the case when the OFF switch is operated or when the connection between the switch and input X002 is interrupted.

This ensures that if there is a cable break the drive is switched off automatically and it is not possible to activate the drive. In addition to this, switching off has priority because it is processed by the program after the switch on instruction.

Interlock contacts

If you have two outputs that should never both be switched on at the same time – for example outputs for selecting forward or reverse operation for a motor – the interlock for the outputs must also be implemented with physical contacts in the contactors controlled by the PLC. This is necessary because only an internal interlock is possible in the program and an error in the PLC could cause both outputs to be activated at the same time.

The example on the right shows such an interlock with contactor contacts. Here it is physically impossible for contactors K1 and K2 to be switched on at the same time.

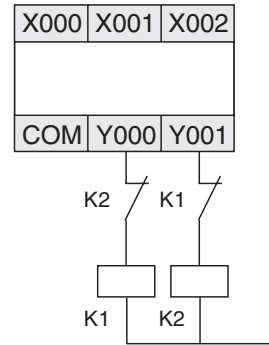

Automatic shutdown

When a PLC is used to control motion sequences in which hazards can arise when components move past certain points additional limit switches must be installed to interrupt the movement automatically. These switches must function directly and independently of the PLC. See Chapter 3.6.2. for an example of such an automatic shutdown facility.

Output signal feedback

Generally, the outputs of PLCs are not monitored. When an output is activated the program assumes that the correct response has taken place outside the PLC. In most cases no additional facilities are required. However, in critical applications you should also monitor the output signals with the PLC – for example when errors in the output circuit (wire breaks, seized contacts) could have serious consequences for safety or system functioning.

In the example on the right a make contact in contactor K1 switches input X002 on when output Y000 is switched on. This allows the program to monitor whether the output and the connected contactor are functioning properly. Note that this simple solution does not check whether the switched equipment is functioning properly (for example if a motor is really turning). Additional functions would be necessary to check this, for example a speed sensor or a voltage load monitor.

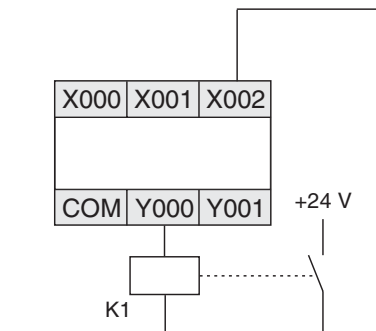

3.6 Programming PLC Applications

Programmable logic controllers provide an almost unlimited number of ways to link inputs with outputs. Your task is to choose the right instructions from the many supported by the controllers of the MELSEC FX family to program a suitable solution for your application.

This chapter provides two simple examples that demonstrate the development of a PLC application from the definition of the task to the finished program,.

3.6.1 An alarm system

The first step is to have a clear concept of what you want to do. This means that you need to take a “bottom-up” approach and write a clear description of what it is you want the PLC to do.

Task description

The objective is to create an alarm system with several alarm circuits and a delay function for arming and disarming the system.

- The system will be armed with a key switch, with a 20-second delay between turning the switch and activation. This provides enough time for the user to leave the house without tripping the alarm. During this delay period a display will show whether the alarm circuits are closed.
- An alarm will be triggered when one of the circuits is interrupted (closed-circuit system, also triggers an alarm when a circuit is sabotaged). In addition to this we want to show which circuit triggered the alarm.
- When an alarm is triggered a siren and a blinking alarm lamp are activated after a delay of 10 seconds. (The acoustic and visual alarms are activated after a delay to make it possible to disarm the system after entering the house. This is also why we want to use a special lamp to show that the system is armed.)
- The siren will only be sounded for 30 seconds, but the alarm lamp will remain activated until the system is disarmed.
- A key-operated switch will also be used to deactivate the alarm system.

Assignment of the input and output signals

The next step is to define the input and output signals we need to process. On the basis of the specifications we know that we are going to need 1 key-operated switch and 4 alarm lamps. In addition to this we need at least 3 inputs for the alarm circuits and 2 outputs for the siren and the blinking alarm lamp. This makes a total of 4 inputs and 6 outputs. Then we assign these signals to the inputs and outputs of the PLC:

Function	Name	Adress	Remarks	
Input	Arm system	S1	X1	Make contact (key-operated switch)
	Alarm circuit 1	S11, S12	X2	Break contacts (an alarm is triggered when the input has the signal state “0”)
	Alarm circuit 2	S21, S22	X3	
	Alarm circuit 3	S31, S32	X4	
Output	Display “system armed”	H0	Y0	The outputs functions are activated when the corresponding outputs are switched on (set). For example, if Y1 is set the acoustic alarm will sound.
	Acoustic alarm (siren)	E1	Y1	
	Optical alarm (rotating beacon)	H1	Y2	
	Alarm circuit 1 display	H2	Y3	
	Alarm circuit 2 display	H3	Y4	
	Alarm circuit 3 display	H4	Y5	

Programming

Now we can start writing the program. Whether relay devices are going to be needed and if so how many usually only becomes clear once you actually start programming. What is certain in this project is that we are going to need three timers for important functions. If we were using a hard-wired controller we would use timer relays for this. In a PLC you have programmable electronic timers (see Chapter 4.3). These timers can also be defined before we start programming:

Function	Address	Remarks
Timer	Arming delay	T0 Time: 20 seconds
	Alarm triggering delay	T1 Time: 10 seconds
	Siren activation duration	T2 Time: 30 seconds

Next we can program the individual control tasks:

- Delayed arming of the alarm system

Ladder Diagram

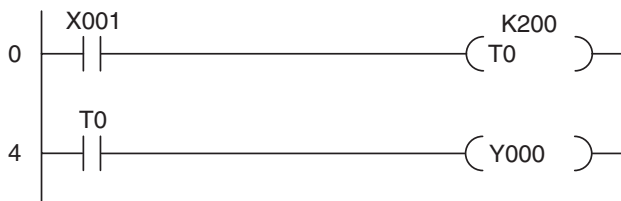

Instruction List

```

0 LD X001
1 OUT T0 K200
4 LD T0
5 OUT Y000
    
```

When the key-operated switch is turned to ON the delay implemented with timer T0 starts to run. After 20 seconds ($K200 = 200 \times 0.1s = 20s$) the indicator lamp connected to output Y000 lights up, indicating that the system is armed.

- Monitor alarm circuits and trigger alarm signal

Ladder Diagram

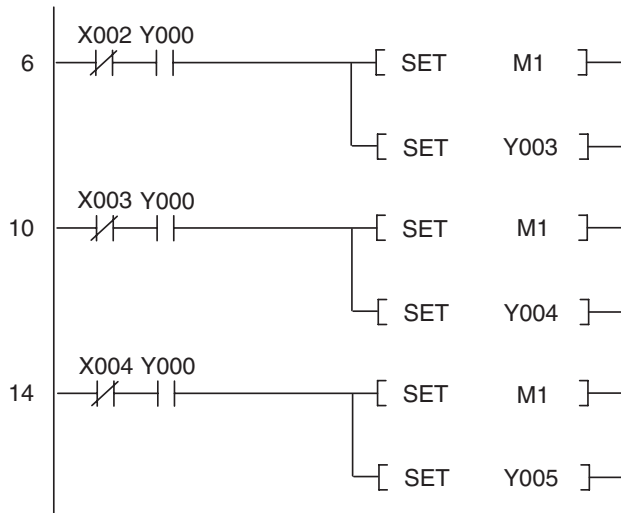

Instruction List

```

6 LDI X002
7 AND Y000
8 SET M1
9 SET Y003
10 LDI X003
11 AND Y000
12 SET M1
13 SET Y004
14 LDI X004
15 AND Y000
16 SET M1
17 SET Y005
    
```

Output Y000 is polled in this routine to check whether the alarm system is armed. You could also use a relay here that would then be set and reset together with Y000. An interruption of an alarm circuit will only set relay M1 (indicating that an alarm has been triggered) if the alarm system is actually armed. In addition to this outputs Y003 through Y005 are used to indicate which alarm circuit triggered the alarm. Relay M1 and the corresponding alarm circuit output will remain set even when the alarm circuit is closed again.

● Alarm activation delay

Ladder Diagram

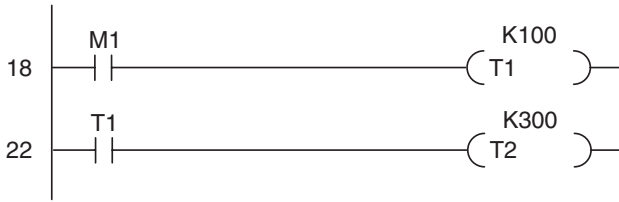

Instruction List

```

18 LD    M1
19 OUT   T1    K100
22 LD    T1
23 OUT   T2    K300
    
```

When an alarm is triggered (M1 switches to “1”) the 10s delay timer starts. After the 10 seconds T1 then starts timer T2, which is set to 30 seconds, and the siren activation time begins.

● Alarm display (switch on siren and rotating beacon)

Ladder Diagram

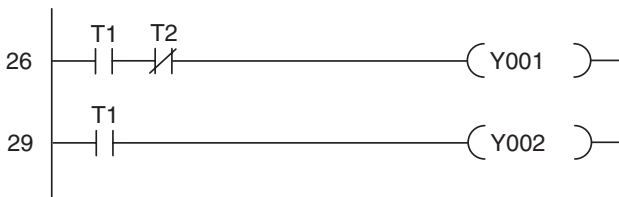

Instruction List

```

26 LD    T1
27 ANI   T2
28 OUT   Y001
29 LD    T1
30 OUT   Y002
    
```

The siren is activated after the 10s activation delay (T1) and remains on while timer T2 is running. After the end of the 30s activation period (T2) the siren deactivates. The rotating beacon is also switched on after the 10s delay. The following illustration shows the signal sequence generated by this section of the program:

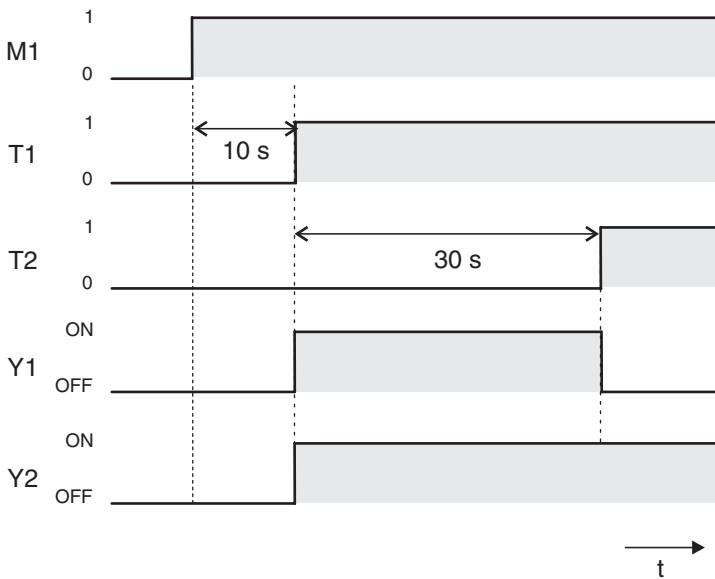

● Resetting all outputs and the relay

Ladder Diagram

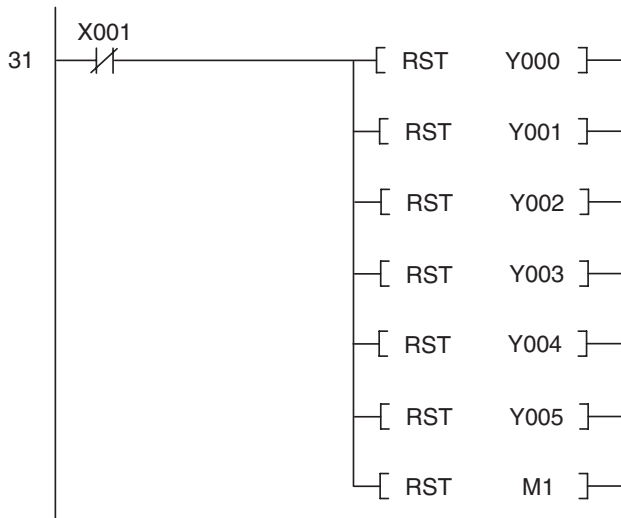

Instruction List

31	LDI	X001
32	RST	Y000
33	RST	Y001
34	RST	Y002
35	RST	Y003
36	RST	Y004
37	RST	Y005
38	RST	M1

When the alarm system is switched off with the key-operated switch all the outputs used by the program and the relay M1 are all reset. If an alarm was triggered the interrupted alarm circuit which was released until the system was switched off is displayed.

Connection of the PLC

The sketch below shows how easy it is to implement this alarm system with a PLC of the FX family. The example shows an FX1N-14MR.

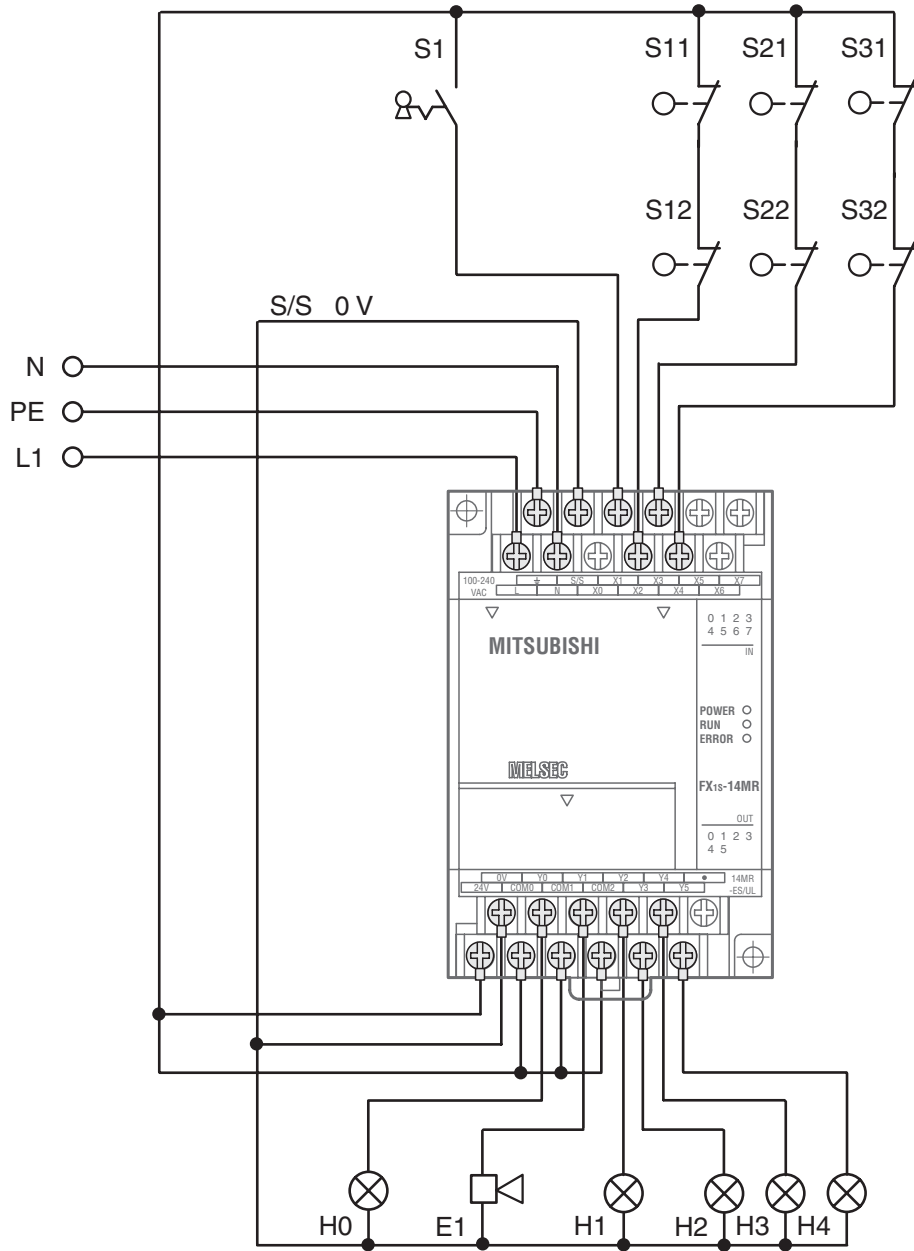

3.6.2 A rolling shutter gate

Task description

We want to implement a control system for a warehouse's rolling shutter gate that will enable easy operation from both outside and inside. Safety facilities must also be integrated in the system.

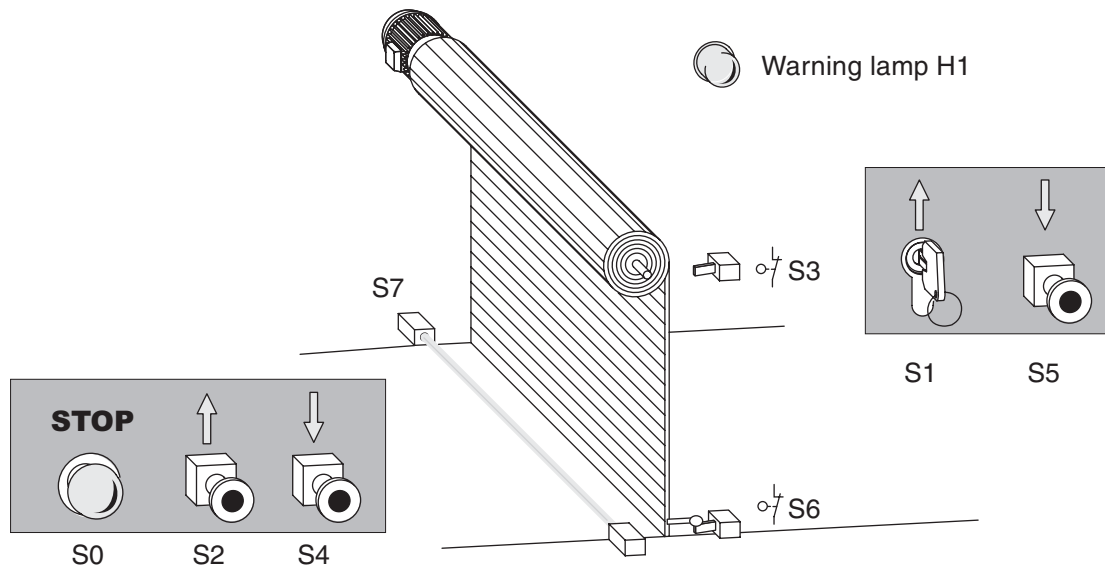

● Operation

- It must be possible to open the gate from outside with the key-operated switch S1 and to close it with pushbutton S5. Inside the hall it should be possible to open the gate with pushbutton S2 and to close it with S4.
- An additional time switch must close the gate automatically if it is open for longer than 20 s.
- The states “gate in motion” and “gate in undefined position” must be indicated by a blinking warning lamp.

● Safety facilities

- A Stop button (S0) must be installed that can halt the motion of the gate immediately at any time, stopping the gate in its current position. This Stop switch is not an Emergency OFF function, however! The switch signal is only processed by the PLC and does not switch any external power connections.
- A photoelectric barrier (S7) must be installed to identify obstacles in the gateway. If it registers an obstacle while the gate is closing the gate must open automatically.
- Two limit switches must be installed to stop the gate motor when the gate reaches the fully open (S3) and fully closed (S6) positions.

Assignment of the input and output signals

The task description clearly defines the number of inputs and outputs needed. The gate drive motor is controlled with two outputs. The signals required are assigned to the PLC inputs and outputs as follows:

Function	Name	Adress	Remarks	
Inputs	STOP button	S0	X0	Break contact (when the switch is operated X0 = "0" and the gate stops)
	OPEN key-operated switch (outside)	S1	X1	Make contacts
	OPEN button (inside)	S2	X2	
	Upper limit switch (gate open)	S3	X3	Break contact (X2 = "0" when the gate is up and S3 is activated)
	CLOSE button (inside)	S4	X4	Make contacts
	CLOSE button (outside)	S5	X5	
	Lower limit switch (gate closed)	S6	X6	Break contact (X6 = "0" when the gate is down and S6 is activated)
	Photoelectric barrier	S7	X7	X7 is set to "1" when an obstacle is registered
Outputs	Warning lamp	H1	Y0	—
	Motor contactor (motor reverse)	K1	Y1	Reverse = OPEN gate
	Motor contactor (motor forward)	K2	Y2	Forward = CLOSE gate
Timer	Delay for automatic close	—	T0	Time: 20 seconds

The program components

- Operation of the rolling shutter gate with the pushbuttons

The program must convert the input signals for the operation of the gate into two commands for the drive motor: "Open Gate" and "Close Gate". Since these are signals from pushbuttons that are only available briefly at the inputs they need to be stored. To do this we use two relays to represent the inputs in the program and set and reset them as required:

- M1: open gate
- M2: close gate

Ladder Diagram

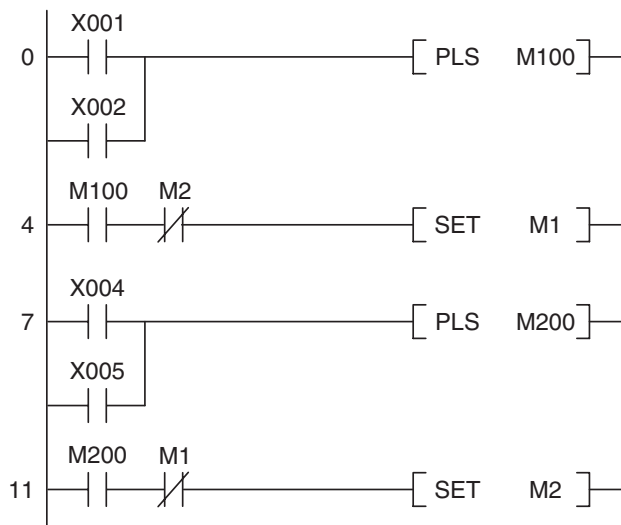

Instruction List

```

0 LD X001
1 OR X002
2 PLS M100
4 LD M100
5 ANI M2
6 SET M1
7 LD X004
8 OR X005
9 PLS M200
11 LD M200
12 ANI M1
13 SET M2
    
```

The signals for opening the gate are processed first: When key-operated switch S1 or button S2 are operated a signal is generated and M001 is set to a signal state of "1" for just one pro-

gram cycle. This ensures that the gate cannot be blocked if the button sticks or of the operator does not release it.

It must be ensured that the drive can only be switched on when it is not already turning in the opposite direction. This is implemented by programming the PLC so that M1 can only be set when M2 is not set.

NOTE

The motor direction interlock must also be complemented by an additional interlock with physical contactors outside the PLC (see wiring diagram).

A similar approach is used to process the signals from buttons S4 and S5 for closing the gate. Here, M1 is polled for a signal state of “0” to ensure that M1 and M2 cannot both be set at the same time.

- Close gate automatically after 20 seconds

Ladder Diagram

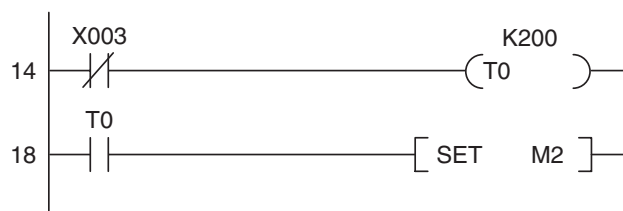

Instruction List

```

14 LDI    X003
15 OUT    T0      K200
18 LD     T0
19 SET    M2
    
```

When the gate is open limit switch S3 activates and input X3 is switched off. (For safety reasons S3 is a break contact.) When this happens timer T0 starts the 20s delay (K200 = 200 x 0.1s = 20s). When the timer reaches 20s relay M2 is set and the gate is closed.

- Stop gate with STOP switch

Ladder Diagram

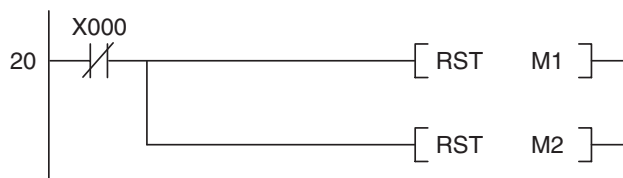

Instruction List

```

20 LDI    X000
21 RST    M1
22 RST    M2
    
```

Pressing the STOP button (S0) resets relays M1 and M2, stopping the gate motor.

- Identifying obstacles with the photoelectric barrier

Ladder Diagram

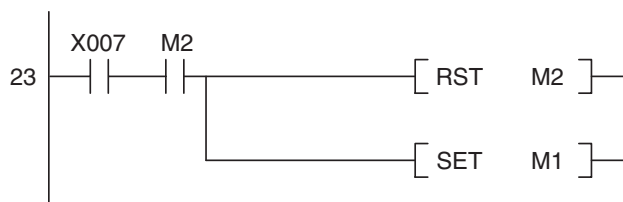

Instruction List

```

23 LD     X007
24 AND    M2
25 RST    M2
26 SET    M1
    
```

If an obstacle is registered by the photoelectric barrier while the gate is closing relay M2 is reset and the close operation is halted. After this relay M1 is set, opening the gate again.

● Switching the motor of with the limit switches

Ladder Diagram

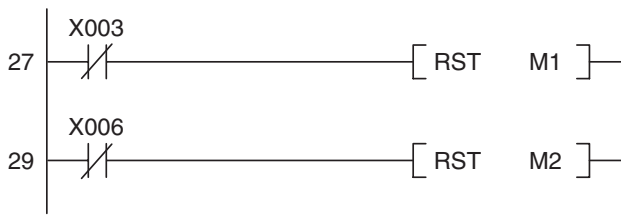

Instruction List

27	LDI	X003
28	RST	M1
29	LDI	X006
30	RST	M2

When the gate is open limit switch S3 is activated and input X3 is switched off. This resets relay M1, turning off the motor. When the gate is fully closed S6 is activated, X6 is switched off and M2 is reset, turning off the motor. For safety reasons the limit switches are break contacts. This ensures that the motor is also switched off automatically (or cannot be switched on) if the connection between the switch and the input is interrupted.

NOTE

The limit switches must be wired so that they also switch off the motor automatically without support from the PLC (see wiring diagram).

● Controlling the motor

Ladder Diagram

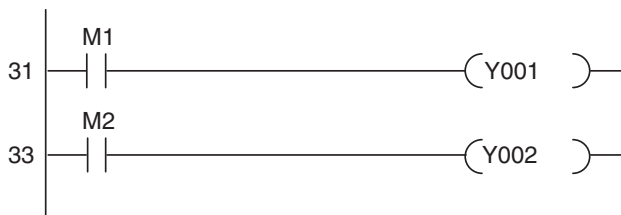

Instruction List

31	LD	M1
32	OUT	Y001
33	LD	M2
34	OUT	Y002

At the end of the program the signal states of relays M1 and M2 are transferred to outputs Y001 and Y002.

● Warning lamp: “Gate in Motion” and “Gate in Undefined Position”

Ladder Diagram

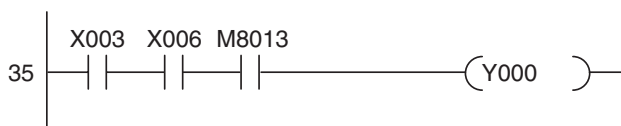

Instruction List

35	LD	X003
36	AND	X006
37	AND	M8013
38	OUT	Y000

If neither of the limit switches is activated this means that the gate is being opened or closed or has been stopped in an intermediate position. In all these situations the warning lamp blinks. The blink speed is controlled with special relay M8013, which is automatically set and reset at 1s intervals (see Chapter 4.2).

Connection of the PLC

The rolling shutter gate control system can be implemented with a controller like the FX1N-14MR.

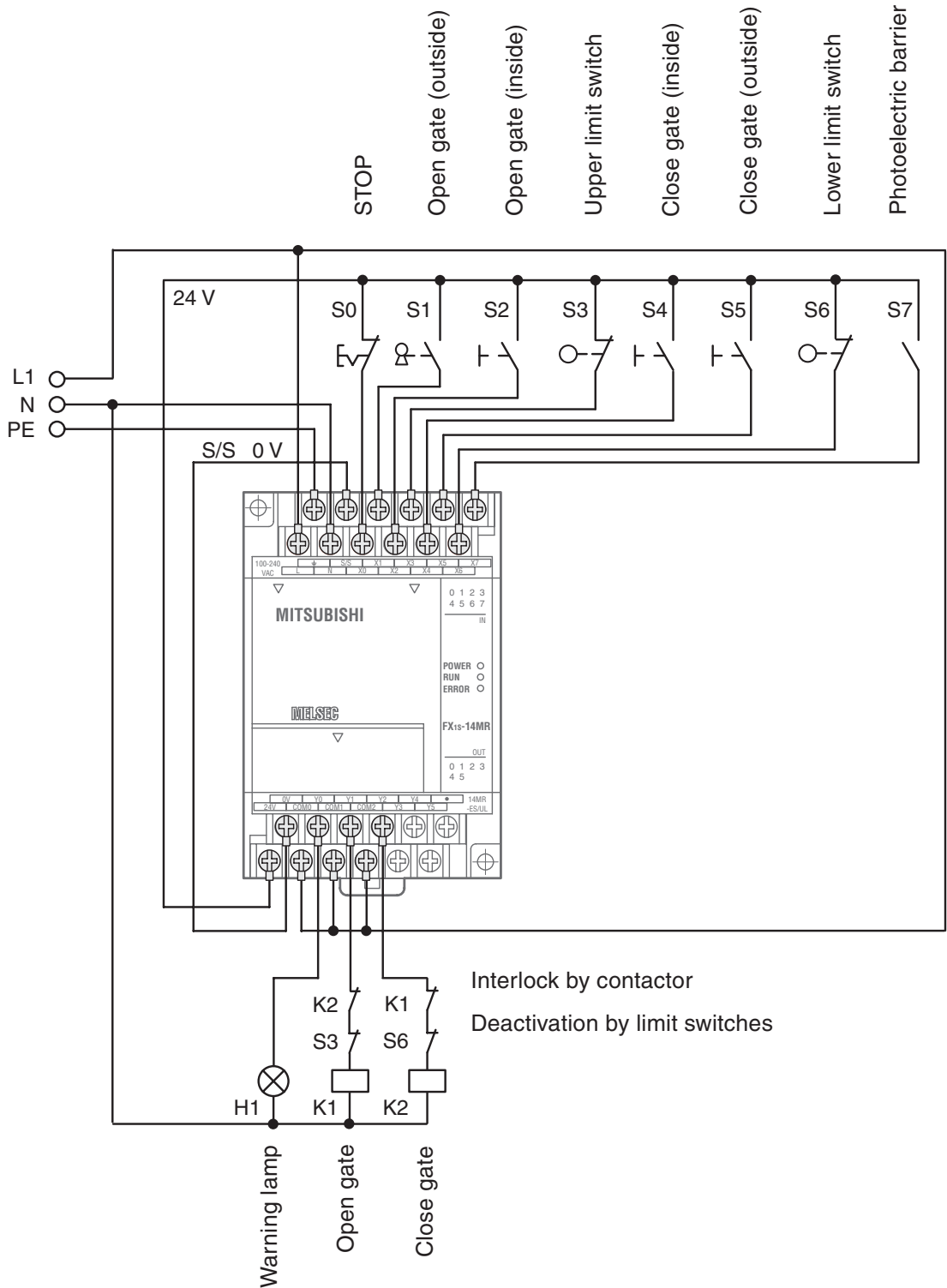

4 Devices in Detail

The devices in PLCs are used directly in control program instructions. Their signal states can be both read and changed by the PLC program. A device reference has two parts:

- the device name and
- the device address.

Example of a device reference (e.g. input 0):



4.1 Inputs and Outputs

The PLC's inputs and outputs connect it to the process that it is controlling. When an input is polled by the PLC program the voltage on the input terminal of the controller is measured. Since these inputs are digital they can only have two signal states, ON or OFF. When the voltage at the input terminal reaches 24V the input is on (state "1"). If the voltage is lower than 24V the input evaluates as off (signal state "0").

In MELSEC PLCs the identifier "X" is used for inputs. The same input can be polled as often as necessary in the same program.

NOTE

The PLC cannot change the state of inputs. For example, it is not possible to execute an OUT instruction on an input device.

If an output instruction is executed on an output the result of the current operation (the signal state) is applied to the output terminal of the PLC. If it is a relay output the relay closes (all relays have make contacts). If it is a transistor output the transistor makes the connection and activates the connected circuit.

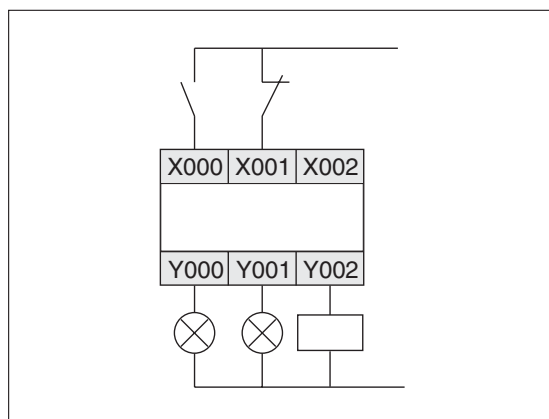

The illustration on the left shows an example of how you can connect switches to the inputs and lamps and contactors to the outputs of a MELSEC PLC.

The identifier for output devices is "Y". Outputs can be used in logic operation instructions as well as with output instructions. However, it is important to remember that you can never use an output instruction on the same output more than once (see also chapter 3.4.2).

The following table provides a general overview of the inputs and outputs of the controllers of the MELSEC FX family.

Device		Inputs	Outputs
Device identifier		X	Y
Device type		Bit device	
Possible values		0 or 1	
Device address format		Octal	
Number of devices and addresses (depends on controller base unit type)	FX1S	6 (X00–X05) 8 (X00–X07) 12 (X00–X07, X10, X11, X12, X13) 16 (X00–X07, X10–X17)	4 (Y00–Y03) 6 (Y00–Y05) 8 (Y00–Y07) 14 (Y00–Y07, Y10–Y15)
	FX1N	8 (X00–X07) 14 (X00–X07, X10–X15) 24 (X00–X07, X10–X17, X20–X27) 36 (X00–X07, X10–X17, X20–X27, X30–X37, X40, X41, X42, X43) The total number of inputs can be increased to max. 84 (X123) with expansion modules. However, the sum of all inputs and outputs cannot exceed 128.	6 (Y00–Y05) 10 (Y00–Y07, Y10, Y11) 16 (Y00–Y07, Y10–Y17) 24 (Y00–Y07, Y10–Y17, Y20–Y27) The total number of outputs can be increased to max. 64 (Y77) with expansion modules. However, the sum of all inputs and outputs cannot exceed 128.
	FX2N	8 (X00–X07) 16 (X00–X07, X10–X17) 24 (X00–X07, X10–X17, X20–X27) 32 (X00–X07, X10–X17, X20–X27, X30–X37) 40 (X00–X07, X10–X17, X20–X27, X30–X37, X40–X47) 64 (X00–X07, X10–X17, X20–X27, X30–X37, X40–X47, X50–X57, X60–X67, X70–X77)	8 (Y00–Y07) 16 (Y00–Y07, Y10–Y17) 24 (Y00–Y07, Y10–Y17, Y20–Y27) 32 (Y00–Y07, Y10–Y17, Y20–Y27, Y30–Y37) 40 (Y00–Y07, Y10–Y17, Y20–Y27, Y30–Y37, Y40–Y47) 64 (Y00–Y07, Y10–Y17, Y20–Y27, Y30–Y37, Y40–Y47, Y50–Y57, Y60–Y67, Y70–Y77)
	FX2NC	8 (X00–X07) 16 (X00–X07, X10–X17) 32 (X00–X07, X10–X17, X20–X27, X30–X37) 48 (X00–X07, X10–X17, X20–X27, X30–X37, X40–X47, X50–X57)	8 (Y00–Y07) 16 (Y00–Y07, Y10–Y17) 32 (Y00–Y07, Y10–Y17, Y20–Y27, Y30–Y37) 48 (Y00–Y07, Y10–Y17, Y20–Y27, Y30–Y37, Y40–Y47, X50–X57)
	FX3U	8 (X00–X07) 16 (X00–X07, X10–X17) 24 (X00–X07, X10–X17, X20–X27) 32 (X00–X07, X10–X17, X20–X27, X30–X37) 40 (X00–X07, X10–X17, X20–X27, X30–X37, X40–X47)	8 (Y00–Y07) 16 (Y00–Y07, Y10–Y17) 24 (Y00–Y07, Y10–Y17, Y20–Y27) 32 (Y00–Y07, Y10–Y17, Y20–Y27, Y30–Y37) 40 (Y00–Y07, Y10–Y17, Y20–Y27, Y30–Y37, Y40–Y47)

* The total number of inputs can be increased to max. 248 (X367) with expansion modules. However, the sum of all inputs and outputs cannot exceed 256.

4.2 Relays

In your PLC programs you will often need to store intermediate binary results (a signal state of “0” or “1”) temporarily for future reference. The PLC has special memory cells available for this purpose known as “auxiliary relays”, or “relays” for short (device identifier: “M”).

You can store the binary result of an operation in a relay, for example with an OUT instruction, and then use the result in future operations. Relays help to make programs easier to read and also reduce the number of program steps: You can store the results of operations that need to be used more than once in a relay and then poll it is often as you like in the rest of the program.

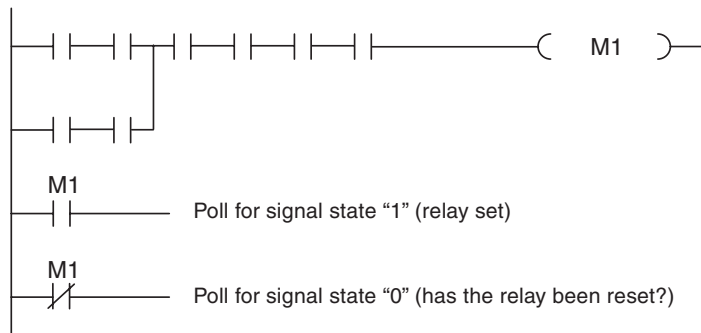

In addition to normal relays the FX controllers also have retentive or “latched” relays. The normal unlatched relays are all reset to a signal state of “0” when the PLC power supply is switched off, and this is also their standard state when the controller is switched on. In contrast to this, latched relays retain their current states when the power is switched off and on again.

Device	Relay types		
	Unlatched relays	Latched relays	
Device identifier	M		
Device type	Bit device		
Possible values für a device	0 or 1		
Device address format	Decimal		
Number of devices and addresses	FX1S	384 (M0–M383)	128 (M384–M511)
	FX1N	384 (M0–M383)	1152 (M384–M1535)
	FX2N FX2NC	500 (M0–M499) ^①	524 (M500–M1023) ^②
			2048 (M1024–M3071)
	FX3U	500 (M0–M499) ^①	524 (M500–M1023) ^② 6656 (M1024–M7679)

① You can also configure these relays as latched relays with the PLC parameters.

② You can also configure these relays as unlatched relays with the PLC parameters.

4.2.1 Special relays

In addition to the relays that you can switch on and off with the PLC program there is also another class of relays known as special or diagnostic relays. These relays use the address range starting with M8000. Some contain information on system status and others can be used to influence program execution. The following table shows a few examples of the many special relays available.

Special relay	Function	Program processing options
M8000	When the PLC is in RUN mode this relay is always set to "1".	Poll signal state
M8001	When the PLC is in Run mode this relay is always set to "0".	
M8002	Initialisation pulse (following activation of RUN mode this relay is set to "1" for the duration of one program cycle.	
M8004	PLC error	
M8005	Low battery voltage	
M8013	Clock signal pulse: 1 second	
M8031	Clear all devices (except data registers D) that are not registered as battery-latched.	Poll signal state
M8034	Disable outputs – the PLC outputs remain off but program execution continues.	Set signal state.

4.3 Timers

When you are controlling processes you will often want to program a specific delay before starting and stopping certain operations. In hard-wired controllers this is achieved with timer relays. In PLCs this is achieved with programmable internal timers.

Timers are really just counters that count the PLCs internal clock signals (e.g. 0.1s pulses). When the counter value reaches the setpoint value the timer's output is switched on.

All timers function as make delay switches and are activated with a "1" signal. To start and reset timers you program them in the same way as outputs. You can poll the outputs of timers as often as you like in your program.

Ladder Diagram



Instruction List

```

0 LD X0
1 OUT T200 K123
4 LD T200
5 OUT Y0
  
```

In the above example timer T200 is started when input X0 is switched on. The setpoint value is $123 \times 10\text{ms} = 1.23\text{ s}$, so T200 switches on output Y0 after a delay of 1.23 s. The signal sequence generated by the following program example is as follows:

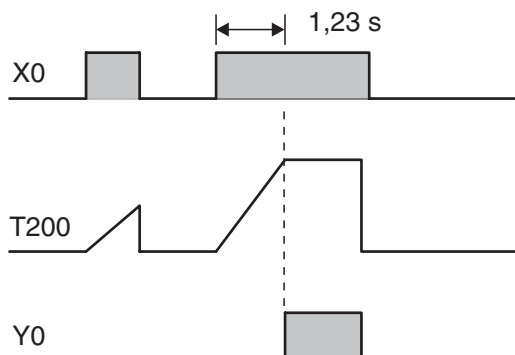

The timer continues to count the internal 10ms pulses as long as X0 remains on. When the setpoint value is reached the output of T200 is switched on.

If input X0 or the power supply of the PLC are switched off the timer is reset and its output is also switched off.

You can also specify the timer setpoint value indirectly with a decimal value stored in a data register. See Chapter 4.6.1 for details.

Retentive timers

In addition to the normal timers described above the controllers of the FX1N, FX2N, FX2NC and FX3U series also have retentive timers that retain their current time counter value even if the device controlling them is switched off.

The current timer counter value is stored in a memory that is retained even in the event of a power failure.

Example of a program using a retentive timer:

Ladder Diagram

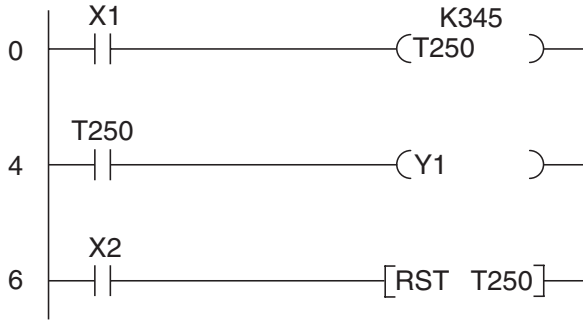

Instruction List

0	LD	X0	
1	OUT	T250	K345
4	LD	T250	
5	OUT	Y1	
6	LD	X2	
7	RST	T250	

Timer T250 is started when input X0 is switched on. The setpoint value is $345 \times 0.1 \text{ s} = 34.5\text{s}$. When the setpoint value is reached T250 switches output Y1 on. Input X2 resets the timer and switches its output off..

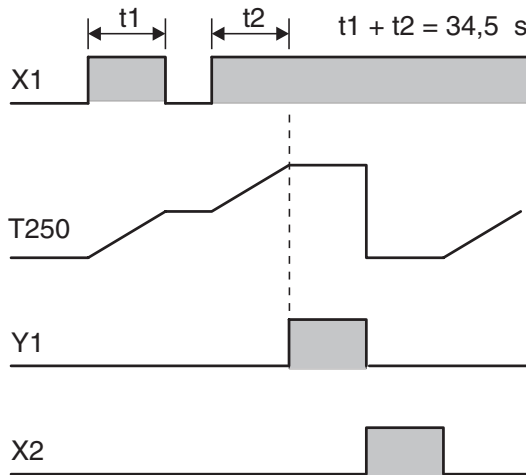

When X1 is on the timer counts the internal 100ms pulses. When X1 is switched off the current time counter value is retained. The timer's output is switched on when the current value reaches the setpoint value of the timer.

A separate instruction must be programmed to reset the timer since it is not reset by switching off input X1 or the PLC's power. Input X2 resets timer T250 and switches off its output..

Timers in the base units of the MELSEC FX family

Device			Timer types	
			Normal Timers	Retentive Timers
Device identifier			T	
Device type (for setting and polling)			Bit device	
Possible values (timer output)			0 or 1	
Device address format			Decimal	
Timer setpoint value entry			As a decimal integer constant. The setpoint can be set either directly in the instruction or indirectly in a data register.	
Number of devices and addresses	FX1S	100 ms (Range 0.1 to 3276.7 s)	63 (T0–T62)	—
		10 ms (Range 0.01 to 327.67 s)	31 (T32–T62)*	—
		1 ms (Bereich 0.001 to 32.767 s)	1 (T63)	—
	FX1N	100 ms (Range 0.1 to 3276.7 s)	200 (T0–T199)	6 (T250–T255)
		10 ms (Range 0.01 to 327.67 s)	46 (T200–T245)	—
		1 ms (Range 0.001 to 32.767 s)	4 (T246–T249)	—
	FX2N FX2NC	100 ms (Range 0.1 to 3276.7 s)	200 (T0–T199)	6 (T250–T255)
		10 ms (Range 0.01 to 327.67 s)	46 (T200–T245)	—
		1 ms (Range 0.001 to 32.767 s)	—	4 (T246–T249)
	FX3U	100 ms (Range 0.1 to 3276.7 s)	200 (T0–T199)	6 (T250–T255)
		10 ms (Range 0.01 to 327.67 s)	46 (T200–T245)	
		1 ms (Range 0.001 to 32.767 s)	256 (T256–T511)	4 (T246–T249)

* These timers are only available when special relay M8028 is set. The total number of 100ms timers is then reduced to 32 (T0 – T31).

4.4 Counters

The programmers of the FX family also have internal counters that you can use for programming counting operations.

Counters count signal pulses that are applied to their inputs by the program. The counter output is switched on when the current counter value reaches the setpoint value defined by the program. Like timers, counter outputs can also be polled as often as you like in the program.

Example of a program using a counter:

Ladder Diagram

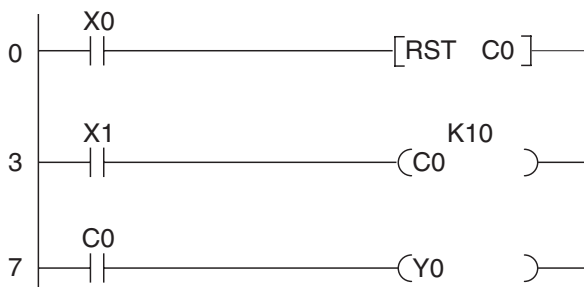

Instruction List

0	LD	X0	
1	RST	C0	
3	LD	X1	
4	OUT	C0	K10
7	LD	C0	
8	OUT	Y0	

Whenever input X1 is switched on the value of counter C0 is incremented by 1. Output Y0 is set when X1 has been switched on and off ten times (the counter setpoint is K10).

The signal sequence generated by this program is as follows:

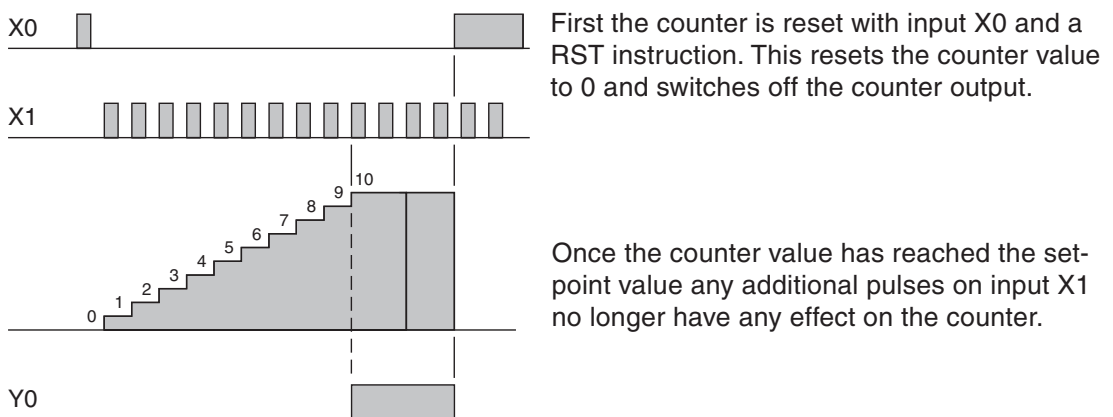

There are two kinds of counters, 16-bit counters and 32-bit counters. As their names indicate, they can count up to either 16-bit or 32-bit values and they use 16 bits and 32 bits, respectively, to store their setpoint values. The following table shows the key features of these counters.

Feature	16 Bit Counters	32 Bit Counters
Count direction	Incrementing	Incrementing and decrementing (the direction is specified by switching a special relay on or off)
Setpoint value range	1 to 32767	-2 147 483 648 to 2 147 483 647
Setpoint value entry	Directly as a decimal constant (K) in the instruction, or indirectly in a data register	Directly as a decimal constant (K) in the instruction or indirectly in a pair of data registers
Counter overflow behaviour	Counts to a maximum of 32,767, after which the counter value no longer changes.	Ring counter: After reaching 2,147,483,647 the next incrementing value is -2,147,483,648. (When counting backwards the jump is from -2,147,483,648 to 2,147,483,647)
Counter output	Once the setpoint value has been reached the output remains on.	When incrementing the output remains on once the setpoint value has been reached. When decrementing the output is reset (switched off) once the value drops below the setpoint value.
Resetting	An RST instruction is used to delete the current value of the counter and turn off its output.	

In addition to normal counters the controllers of the MELSEC FX family also have high-speed counters. These are 32-bit counters that can process high-speed external counter signals read on inputs X0 to X7. In combination with some special instructions it is very easy to use these counters to automate positioning tasks and other functions.

High-speed counters use an interrupt principle: The PLC program is interrupted and responds immediately to the counter signal. For a detailed description of high-speed counters please refer to the Programming Manual for the MELSEC FX family.

Counter overview

Device		Counter types		
		Normal counters	Retentive counters ^①	
Device identifier		C		
Device type (for setting and polling)		Bit device		
Possible device values (counter output)		0 or 1		
Device address format		Decimal		
Counter setpoint value entry		As a decimal integer constant. The setpoint can be set either directly in the instruction or indirectly in a data register (two data registers for 32-bit counters).		
Number of devices and addresses	FX1S	16 bit counter	16 (C0–C15)	16 (C16–C31)
		32 bit counter	—	—
		32 bit high-speed counter	—	21 (C235–C255)
	FX1N	16 bit counter	16 (C0–C15)	184 (C16–C199)
		32 bit counter	20 (C200–C219)	15 (C220–C234)
		32 bit high-speed counter	—	21 (C235–C255)
	FX2N FX2NC	16 bit counter	100 (C0–C99) ^②	100 (C100–C199) ^②
		32 bit counter	20 (C200–C219) ^②	15 (C220–C234) ^③
		32 bit high-speed counter	21 (C235–C255) ^②	
	FX3U	16 bit counter	100 (C0–C99) ^②	100 (C100–C199) ^②
		32 bit counter	20 (C200–C219) ^②	15 (C220–C234) ^②
		32 bit high-speed counter	21 (C235–C255) ^②	

① The current counter values of retentive counters are retained when the power supply is switched off.

② You can set the PLC parameters to configure whether the current values of these counters should be retained when the power supply is switched off.

4.5 Registers

The PLC’s relays are used to store the results of operations temporarily. However, relays can only store values of On/Off or 1/0, which means that they are not suitable for storing measurements or the results of calculations. Values like this can be stored in the “registers” of the controllers of the FX family.

Registers are 16 bits or one word wide (see Chapter 3.2). You can create “double word” registers capable of storing 32-bit values by combining two consecutive data registers.

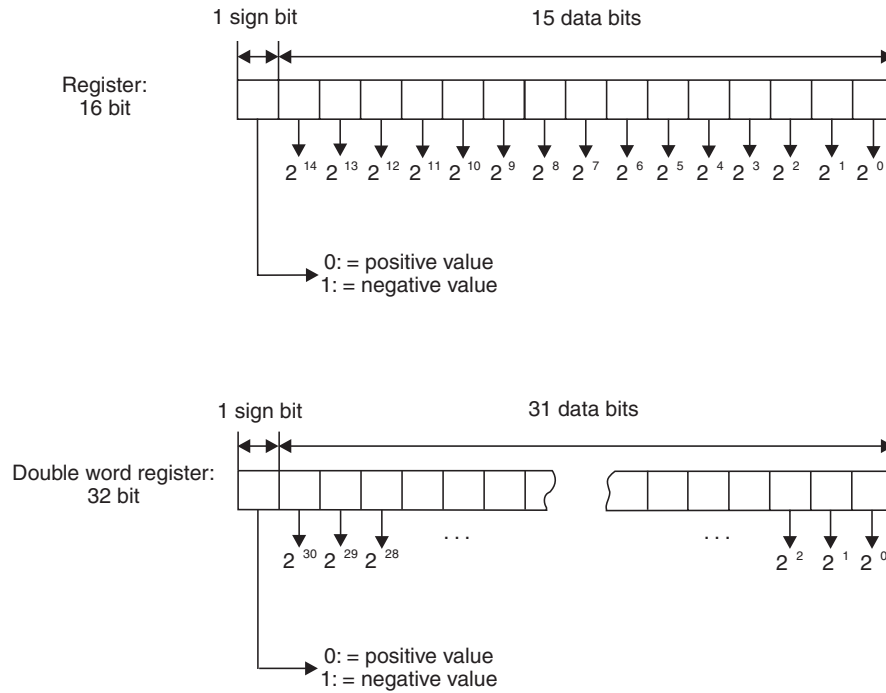

A normal register can store values from 0000H – FFFFH (-32,768 – 32,767). Double-word registers can store values from 00000000H – FFFFFFFFH (-2,147,483,648 – 2,147,483,647).

The controllers of the FX family have a large number of instructions for using and manipulating registers. You can write and read values to and from registers, copy the contents of registers, compare them and perform math functions on their contents (see chapter 5).

4.5.1 Data registers

Data registers can be used as memory in your PLC programs. A value that the program writes to a data register remains stored there until the program overwrites it with another value.

When you use instructions for manipulating 32-bit data you only need to specify the address of a 16-bit register. The more significant part of the 32-bit data is automatically written to the next consecutive register. For example, if you specify register D0 to store a 32-bit value D0 will contain bits 0 through 15 and D1 will contain bits 16 through 31.

What happens when the PLC is switched off or stopped

In addition to the normal registers whose contents are lost when the PLC is stopped or the power supply is turned off, the FX PLCs also have latched registers, whose contents are retained in these situations.

NOTE

When special relay M8033 is set the contents of the unlatched data registers are also not cleared when the PLC is stopped.

Data register overview

Device	Data register types		
	Normal registers	Latched registers	
Device identifier	D		
Device type (for setting and polling)	Word device (two registers can be combined to store double-word values)		
Possible device values	16 bit registers: 0000H to FFFFH (-32768 to 32767) 32 bit register: 00000000H to FFFFFFFFH (-2 147 483 648 to 2 147 483 647)		
Device address format	Decimal		
Number of devices and addresses	FX1S	128 (D0–D127)	128 (D128–D255)
	FX1N	128 (D0–D127)	7872 (D128–D7999)
	FX2N	200 (D0–D199) ^①	312 (D200–D511) ^②
	FX2NC		7488 (D512–D7999)
	FX3U	200 (D0–D199) ^①	524 (M500–M1023) ^②
	6656 (M1024–M7679)		

① You can also configure these registers as latched registers with the PLC parameters.

② You can also configure these registers as unlatched registers with the PLC parameters.

4.5.2 Special registers

Just like the special relays (Chapter 4.2.1) starting at address M8000 the FX controllers also have special or diagnostic registers, whose addresses start at D8000. Often there is also a direct connection between the special relays and special registers. For example, special relay M8005 shows that the voltage of the PLC's battery is too low, and the corresponding voltage value is stored in special register D8005. The following table shows a small selection of the available special registers as examples.

Special register	Function	Program processing optionsm
D8004	Error relay address (shows which error relays are set)	Read register contents
D8005	Battery voltage (e.g. the value "36" means 3.6V)	
D8010	Current program cycle time	
D8013–D8019	Time and date of the integrated real-time clock	Read register contents Change register contents
D8030	Value read from potentiometer VR1 (0 – 255)	Read register contents (FX1S and FX1N only)
D8031	Value read from potentiometer VR2 (0 – 255)	

Registers with externally modifiable contents

The controllers of the FX1S and FX1N series have two integrated potentiometers with which you can adjust the contents of special registers D8030 and D8031 in the range from 0 to 255 (see Chapter 4.6.1). These potentiometers can be used for a variety of purposes – for example to adjust setpoint values for timers and counters without having to connect a programming unit to the controller.

4.5.3 File registers

The contents of file registers are also not lost when the power supply is switched off. File registers can thus be used for storing values that you need to transfer to data registers when the PLC is switched on, so that they can be used by the program for calculations, comparisons or as setpoints for timers.

File registers have the same structure as data registers. In fact, they are data registers – they consist of blocks of 500 addresses each in the range from D1000 to D7999.

Device		File registers
Device identifier		D
Device type (for setting and polling)		Word device (two registers can be combined to store double-word values)
Possible device values		16 bit register: 0000H to FFFFH (-32768 to 32767) 32 bit register: 00000000H to FFFFFFFFH (-2 147 483 648 to 2 147 483 647)
Device address format		Decimal
Number of devices and addresses	FX1S	1500 (D1000–D2499) A maximum of 3 blocks of 500 file registers each can be defined in the PLC parameters.
	FX1N	7000 (D1000–D7999) A maximum of 14 blocks of 500 file registers each can be defined in the PLC parameters.
	FX2N	
	FX2NC	
	FX3U	

For a detailed description of the file registers see the Programming Manual for the MELSEC FX family.

4.6 Programming Tips for Timers and Counters

4.6.1 Specifying timer and counter setpoints indirectly

The usual way to specify timer and counter setpoint values is directly, in an output instruction:

Ladder Diagram

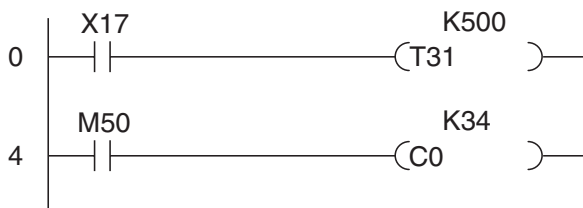

Instruction List

```

0 LD X17
1 OUT T31 K500
4 LD M50
5 OUT C0 K34
    
```

In the example above T31 is a 100ms timer. The constant K500 sets the delay to 500 x 0.1s = 50s. The setpoint for counter C0 is also set directly, to a value of 34 with the constant K34.

The advantage of specifying setpoints like this is that you don't have to concern yourself with the setpoint value once you have set it. The values you use in the program are always valid, even after power failures and directly after switching the controller on. However, there is also a disadvantage: If you want to change the setpoint you need to edit the program. This applies particularly for timer setpoint values, which are often adjusted during controller configuration and program tests.

You can also store setpoint values for timers and counters in data registers and have the program read them from the registers. It is then possible to change the values quickly with a pro-

programming unit if necessary, or to specify setpoint values with switches on a control console or a HMI control panel.

The following listing shows an example of how to specify setpoint values indirectly:

Ladder Diagram

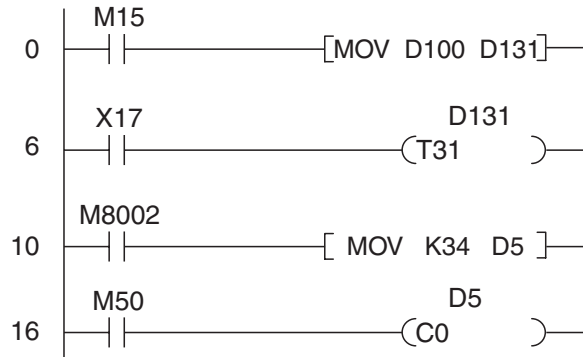

Instruction List

0	LD	M15	
1	MOV	D100	D131
6	LD		X17
7	OUT	T31	D131
10	LD	M8002	
11	MOV	K34	D5
16	LD	M50	
17	OUT	C0	D5

- When relay M15 is one the contents of data register D100 are copied to D131. This register contains the setpoint value for T131. You could use a programming or control unit to adjust the contents of D100.
- The special relay M8002 is only set for a single program cycle directly after the PLC is switched on. This is used to copy the constant value of 34 to data register D5, which is then used as the setpoint value for counter C0.

You don't have to write program instructions to copy the setpoint values to the data registers. You could also use a programming unit to set them before the program is started, for example.



WARNING:

If you use normal registers the setpoint values will be lost when the power supply is switched off and when the RUN/STOP switch is set to the STOP position. If this happens hazardous conditions may be created next time the power is switched on and/or when the PLC is started again, because all the setpoints will have a value of "0".

If you don't configure your program to copy the values automatically you should always use latched data registers for storing the setpoint values for timers and counters. Also, remember that even the contents of these registers will also be lost when the PLC is switched off if the backup battery is empty.

Setting setpoints with the integrated potentiometers

The controllers of the FX1S and FX1N series have two integrated analog potentiometers with which you can adjust setpoint values for timers and other functions quickly and easily.

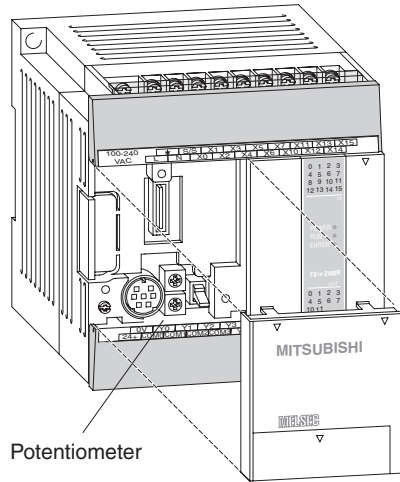

The value of the upper potentiometer (VR1) can be read from special data register D8031, the value of the lower potentiometer (VR2) from register D8031. To use one of the potentiometers as the setpoint value source for a timer you just specify the corresponding register in your program instead of a constant.

The value in the register can be adjusted between 0 and 255 by turning the potentiometer.

Ladder Diagram

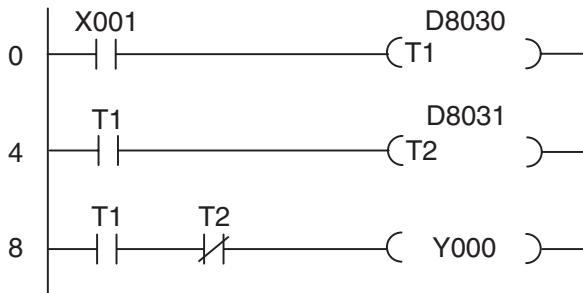

Instruction List

0	LD	X001	
1	OUT	T1	D8030
4	LD	T1	
5	OUT	T2	D8031
8	LD	T1	
8	ANI	T2	
10	OUT	Y000	

In the program example above Y0 is switched on after the delay specified for timer T1, for the time specified for timer T2 (delayed pulse generation).

Signal sequence

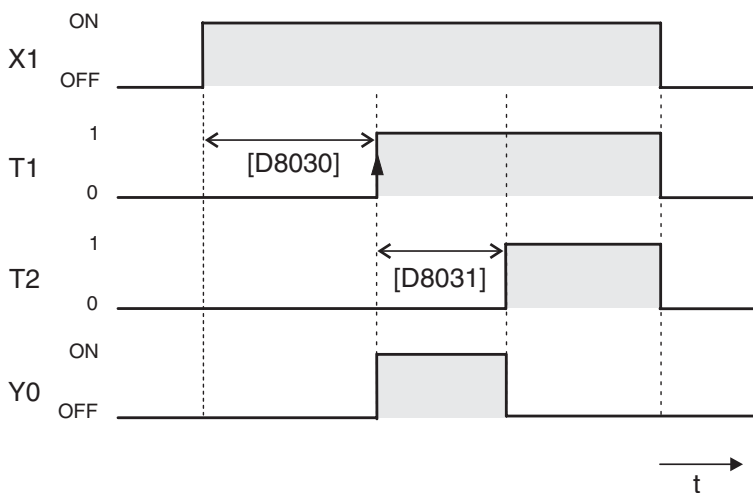

4.6.2 Switch-off delay

By default, all the timers in MELSEC PLCs are delayed make timers, i.e. the output is switched ON after the defined delay period. However, you will often also want to program a delayed break operation (switch OFF after a delay). A typical example of this is a ventilation fan in a bathroom that needs to continue running for several minutes after the lights are switched off.

Program version 1 (latching)

Ladder Diagram

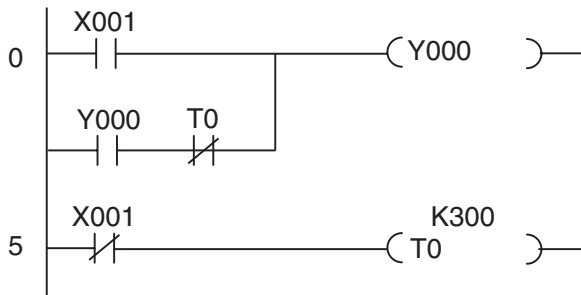

Instruction List

0	LD		X001
1	LD		Y000
2	ANI	T0	
3	ORB		
4	OUT	Y000	
5	LDI	X001	
6	OUT	T0	K300

As long as input X1 (e.g. a light switch) is on output Y0 (fan) is also on. However, the latching function ensures that Y0 also remains on after X1 has been switched off, because timer T0 is still running. T0 is started when X1 is switched off. At the end of the delay period (300 x 0.1s = 30s in the example) T0 interrupts the Y0 latch and switches the output off.

Signal sequence

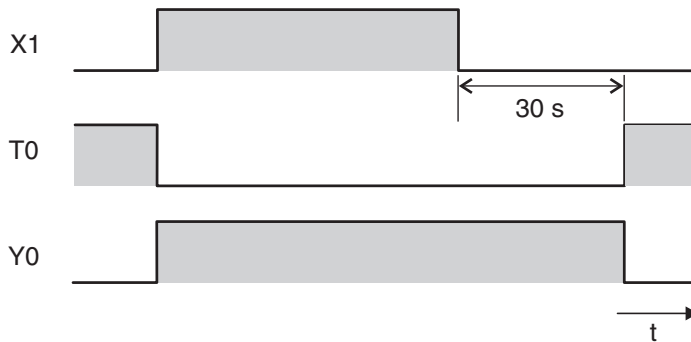

Program version 2 (set/reset)

Ladder Diagram

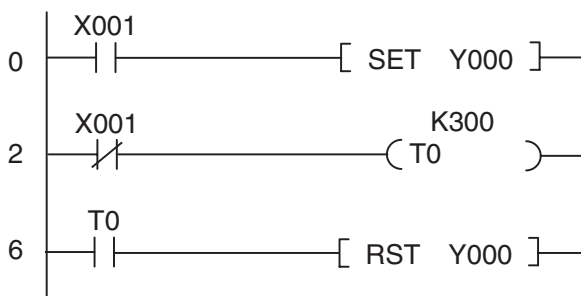

Instruction List

0	LD	X001	
1	SET	Y000	
2	LDI	X001	
3	OUT	T0	K300
6	LD		T0
7	RST	Y000	

When X1 is switched on output Y0 is set (switched on). When X1 is switched off timer T0 is started. After the delay period T0 then resets output Y0. The resulting signal sequence is identical with that produced by program version 1.

4.6.3 Delayed make and break

Sometimes you will want to switch an output on after a delay and then switch it off again after another delay. This is very easy to implement with the controller's basic logical instructions.

Ladder Diagram

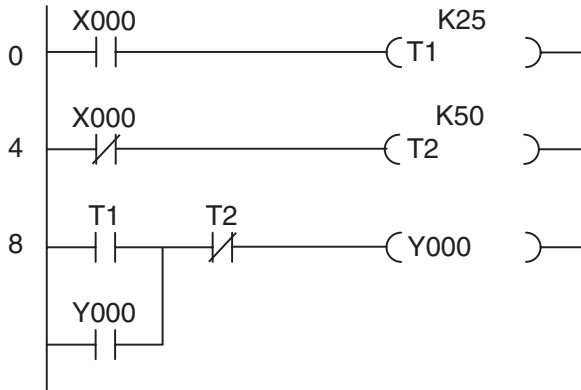

Instruction List

0	LD	X000	
1	OUT	T1	K25
4	LDI	X000	
5	OUT	T2	K50
8	LD	T1	
9	OR	Y000	
10	ANI	T2	
11	OUT	Y000	

Signal sequence

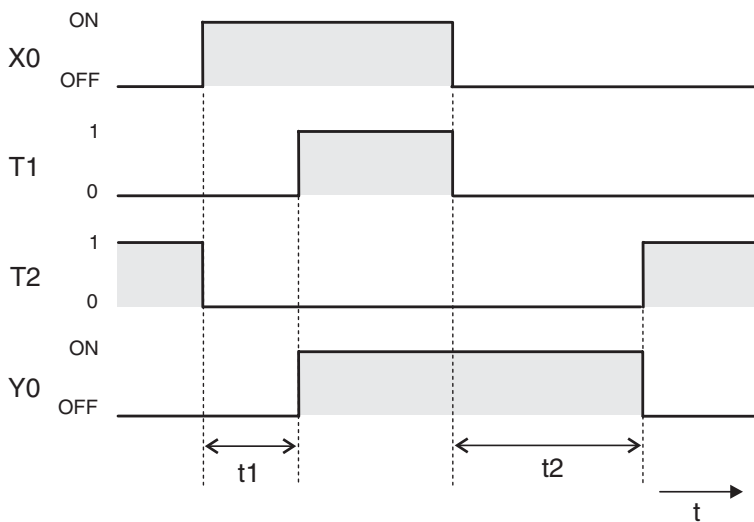

Output Y000 is latched with the help of T1, keeping the output switched on until the end of the break delay period.

4.6.4 Clock signal generators

The controllers have special relays that make it very easy to program tasks requiring a regular clock signal (for example for controlling a blinking error indicator light). Relay M8013 switches on and off at 1-second intervals, for example. For full details on all special relays see the Programming Manual for the FX family.

If you need a different clock frequency or different on and off times you can program your own clock signal generator with two timers, like this:

Ladder Diagram

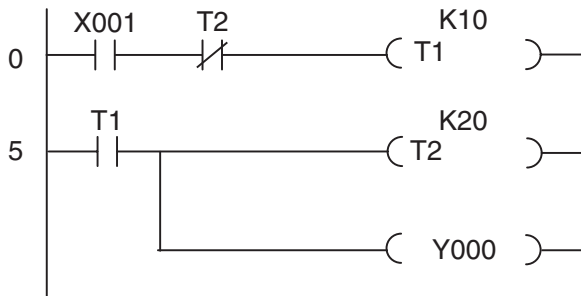

Instruction List

0	LD	X001	
1	ANI	T2	
2	OUT	T1	K10
5	LD	T1	
6	OUT	T2	K20
9	OUT	Y000	

Input X1 starts the clock generator. If you want, you can omit this input – then the clock generator is always on. In the program you could use the output of T1 to control a blinking warning light. The on period is determined by T2, the off period by T1.

The output of timer T2 is only switched on for a single program cycle. This time is shown much longer than it really is in the signal sequence illustration below. T2 switches T1 off and immediately after this T2 itself is also switched off. In effect this means that the duration of the on period is increased by the time that it takes to execute a program cycle. However, since the cycle is only a few milliseconds long it can usually be ignored.

Signal sequence

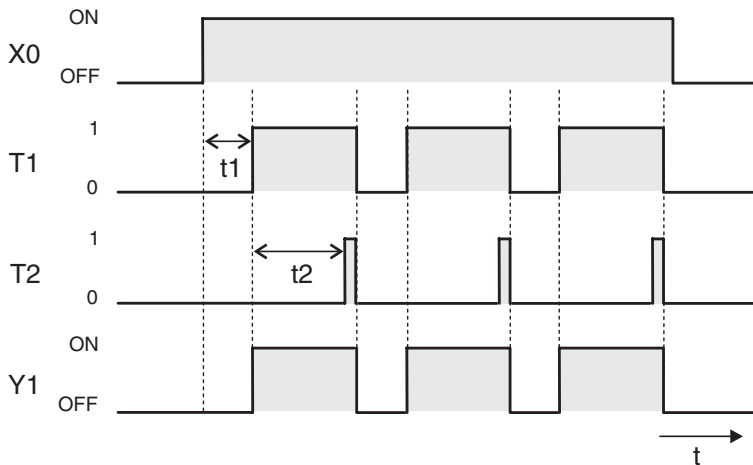

5 More Advanced Programming

The basic logic instructions listed in Chapter 3 can be used to emulate the functions of a hard-wired contactor controller with a programmable logic controller. However, this only scratches the surface of the capabilities of modern PLCs. Since every PLC is built around a microprocessor they can also easily perform operations like mathematical calculations, comparing numbers, converting from one number system to another or processing analog values.

Functions like these that go beyond the capabilities of logic operations are performed with special instructions, which are referred to as *applied* or *application instructions*.

5.1 Applied Instructions Reference

Applied instructions have short names that are based on the English names of their functions. For example, the instruction for comparing two 16-bit or 32-bit numbers is called CMP, which is short for *compare*.

When you program an applied instruction you enter the instruction name followed by the device name. The following table shows all the applied instructions currently supported by the MELSEC FX family of controllers. This list may look a little overwhelming at first, but don't worry – you don't have to memorise them all! When you are programming you can use the powerful Help functions of GX Developer and GX IEC Developer to find the instructions you need.

In this chapter we will only cover the more frequently-used instructions, which are shown with a grey shaded background in the reference table. For full documentation of all the instructions with examples please refer to the Programming Manual for the FX family.

Category	Instruction	Function	Controller				
			FX1S	FX1N	FX2N	FX2NC	FX3U
Program flow functions	CJ	Conditional Jump to a program position					
	CALL	Calls (executes) a subroutine					
	SRET	Subroutine Return, marks the end of a subroutine					
	IRET	Interrupt Return, marks the end of an interrupt routine					
	EI	Enable Interrupt, enables processing of interrupt routines	●	●	●	●	●
	DI	Disable Interrupt, disables processing of interrupt routines					
	FEND	First End, marks end of main program block					
	WDT	WatchDog Timer refresh					
	FOR	Marks beginning of a program loop					
	NEXT	Marks end of a program loop					
Move and compare functions	CMP	Compare numerical values	●	●	●	●	●
	ZCP	Zone Compare, compares numerical ranges	●	●	●	●	●
	MOV	Move data from one storage area to another	●	●	●	●	●
	SMOV	Shift Move			●	●	●
	CML	Compliment, copies and inverts			●	●	●
	BMOV	Block Move	●	●	●	●	●
	FMOV	Fill Move, copy to a range of devices			●	●	●
	XCH	Exchange data in specified devices			●	●	●
	BCD	BCD conversion	●	●	●	●	●
	BIN	Binary conversion	●	●	●	●	●

Category	Instruction	Function	Controller				
			FX1S	FX1N	FX2N	FX2NC	FX3U
Math and logic instructions	ADD	Add numerical values	●	●	●	●	●
	SUB	Subtract numerical values	●	●	●	●	●
	MUL	Multiply numerical values	●	●	●	●	●
	DIV	Divide numerical values	●	●	●	●	●
	INC	Increment	●	●	●	●	●
	DEC	Decrement	●	●	●	●	●
	AND	Logical AND	●	●	●	●	●
	OR	Logical OR	●	●	●	●	●
	XOR	Logical exclusive OR	●	●	●	●	●
	NEG	Negation, logical inversion of device contents			●	●	●
Rotate and shift functions	ROR	Rotate right			●	●	●
	ROL	Rotate left			●	●	●
	RCR	Rotate carry right, rotate right with carry			●	●	●
	RCL	Rotate carry left, rotate left with carry			●	●	●
	SFTR	Shift right, bitwise shift to the right	●	●	●	●	●
	SFTL	Shift left, bitwise shift to the left	●	●	●	●	●
	WSFR	Word shift right, shift word values to the right			●	●	●
	WSFL	Word shift left, shift word values to the left			●	●	●
	SFWR	Shift register write, writes to a FIFO stack	●	●	●	●	●
	SFRD	Shift register read, reads from a FIFO stack	●	●	●	●	●
Data operation functions	ZRST	Zone Reset, resets ranges of like devices	●	●	●	●	●
	DECO	Decode data	●	●	●	●	●
	ENCO	Encode data	●	●	●	●	●
	SUM	Sum (number) of active bits			●	●	●
	BON	Bit on, checks status of a bit			●	●	●
	MEAN	Calculates mean values			●	●	●
	ANS	Timed annunciator set, starts a timer interval			●	●	●
	ANR	Annunciator reset			●	●	●
	SQR	Square root			●	●	●
	FLT	Floating point, converts data			●	●	●
High-speed instructions	REF	Refresh inputs and outputs	●	●	●	●	●
	REFF	Refresh inputs and filter adjust			●	●	●
	MTR	Input matrix, read a matrix (MTR)			●	●	●
	DHSCS	High-speed counter set	●	●	●	●	●
	DHSCR	High-speed counter reset	●	●	●	●	●
	DHSZ	High speed zone compare			●	●	●
	SPD	Speed detection	●	●	●	●	●
	PLSY	Pulse Y output (frequency)	●	●	●	●	●
	PWM	Pulse output with pulse width modulation	●	●	●	●	●
	PLSR	Pulse ramp (acceleration/deceleration setup)	●	●	●	●	●
Application instructions	IST	Initial state, set up multi-mode STL system	●	●	●	●	●
	SER	Search data stack			●	●	●
	ABSD	Absolute counter comparison	●	●	●	●	●
	INCD	Incremental counter comparison	●	●	●	●	●
	TTMR	Teaching timer			●	●	●
	STMR	Special timer			●	●	●
	ALT	Alternate state, flip-flop function	●	●	●	●	●
	RAMP	Ramp function	●	●	●	●	●
	ROTC	Rotary table control			●	●	●
	SORT	Sort table data on selected fields			●	●	●

Category	Instruction	Function	Controller				
			FX1S	FX1N	FX2N	FX2NC	FX3U
Instructions for external I/O devices	TKY	Ten key input			●	●	●
	HKY	Hexadecimal key input			●	●	●
	DSW	Digital switch	●	●	●	●	●
	SEGD	7-segment display decoder			●	●	●
	SEGL	7-segment display with latch	●	●	●	●	●
	ARWS	Arrow switch			●	●	●
	ASC	ASCII conversion			●	●	●
	PR	Print, data output via the outputs			●	●	●
	FROM	Read data from a special function module		●	●	●	●
	TO	Write data to a special function module		●	●	●	●
Instructions for external serial devices	RS	RS serial communications	●	●	●	●	●
	PRUN	Parallel run (octal mode)	●	●	●	●	●
	ASCI	Convert to an ASCII character	●	●	●	●	●
	HEX	Convert to a hexadecimal character	●	●	●	●	●
	CCD	Check Code, sum and parity check	●	●	●	●	●
	VRRD	Read setpoint values from FX1N-8AV-BD and FX2N-8AV-BD	●	●	●	●	●
	VRSC	Read switch settings from FX1N-8AV-BD and FX2N-8AV-BD	●	●	●	●	●
	RS2	RS serial communications (2)					●
Store/restore index registers	PID	Program a PID control loop	●	●	●	●	●
	ZPOP	Zone pop, restore contents of index registers					●
Floating point operations	ZPUSH	Zone push, store contents of index registers					●
	DECOMP	Compare floating point values			●	●	●
	DEZCP	Compare floating point values (range)			●	●	●
	DEMOV	Move floating point values					●
	DESTR	Convert floating point value to a string					●
	DEVAL	Convert string to floating point value					●
	DEBCD	Convert floating point value to scientific notation			●	●	●
	DEBIN	Convert scientific notation to floating point			●	●	●
	DEADD	Add floating point numbers			●	●	●
	DESUB	Subtract floating point numbers			●	●	●
	DEMUL	Multiply floating point numbers			●	●	●
	DEDIV	Divide floating point numbers			●	●	●
	DEXP	Floating point exponent					●
	DLOGE	Calculate natural logarithm					●
	DLOG10	Calculate decadic logarithm					●
	DESQR	Square root of floating point numbers			●	●	●
	DENEG	Reverse sign of floating point numbers					●
	Trigonometry instructions for floating point numbers	INT	Convert floating-point numbers to integers			●	●
SIN		Calculate the sine			●	●	●
COS		Calculate the cosine			●	●	●
TAN		Calculate the tangent			●	●	●
ASIN		Calculate the arc sine					●
ACOS		Calculate the arc cosine					●
ATAN		Calculate the arc tangent					●
RAD		Convert degrees to radians					●
DEG	Convert radians to degrees					●	

Category	Instruction	Function	Controller				
			FX1S	FX1N	FX2N	FX2NC	FX3U
Data operations	WSUM	Sum of the contents of word devices					●
	WTOB	Word to byte, divide words into bytes					●
	BTOW	Byte To Word, form words from individual bytes					●
	UNI	Combine groups of 4 bits to form words					●
	DIS	Divide words into groups of 4 bits					●
	SWAP	Swap least and most significant bits			●	●	●
	SORT	Sort the data in a table					●
Positioning instructions	DSZR	Return to zero home point (with proximity switch)					●
	DVIT	Positioning with interrupt					●
	TBL	Positioning with data table					●
	DABS	Read absolute current position	●	●	●	●	●
	ZRN	Return to zero home point	●	●			●
	PLSV	Output pulses with variable frequency	●	●			●
	DRVI	Position to an incremental value	●	●			●
	DRVA	Position to an absolute value	●	●			●
Operations with the PLC's integrated clock	TCMP	Compare clock data	●	●	●	●	●
	TZCP	Compare clock data with a zone (range)	●	●	●	●	●
	TADD	Add clock data	●	●	●	●	●
	TSUB	Subtract clock data	●	●	●	●	●
	HTOS	Convert hours / minutes / seconds time value to seconds					●
	STOH	Convert seconds time value to hours / minutes / seconds					●
	TRD	Read clock time and date	●	●	●	●	●
	TWR	Write time and date to PLC clock	●	●	●	●	●
	HOUR	Operating hours counter	●	●	●	●	●
Gray code conversion	GRY	Convert Gray code to decimal			●	●	●
	GBIN	Convert decimal number to Gray code			●	●	●
Data exchange with analog modules	RD3A	Read analog input values		●	●	●	●
	WR3A	Write analog output values		●	●	●	●
Instructions in external memory	EXTR	Execute command stored in an external ROM			●	●	
Miscellaneous instructions	COMRD	Read device comment					
	RND	Generate a random number					
	DUTY	Generate a pulse with a defined length					●
	CRC	Check data (CRC check)					
	HCMOV	Move the current value of a high-speed counter					
Instructions for data stored in consecutive devices (data blocks)	BK+	Add data in a data block					
	BK-	Subtract data in a data block					
	BKCMP=	Compare data in data blocks					
	BKCMP>						
	BKCMP<						●
	BKCMP<>						
	BKCMP<=						
BKCMP>=							

Category	Instruction	Function	Controller					
			FX1S	FX1N	FX2N	FX2NC	FX3U	
String operations	STR	Convert binary data to a string						
	VAL	Convert a string to binary data						
	\$+	Concatenate strings						
	LEN	Returns the length of a string						
	RIGHT	Extract substring from right					●	
	LEFT	Extract substring from left						
	MIDR	Select a character string						
	MIDW	Replace a character strings						
	INSTR	Search for a character string						
	\$MOV	Move a character string						
Data table operations	FDEL	Delete data from a table						
	FINS	Insert data in a table						
	POP	Read last data inserted in a table					●	
	SFR	Shift a 16-bit data word right						
	SFL	Shift a 16-bit data word left						
Comparison operations	LD=	Compare data within operations						
	LD>							
	LD<							
	LD<>							
	LD<=							
	LD>=							
	AND=			●	●	●	●	●
	AND>							
	AND<							
	AND>=							
	OR=							
	OR>							
	OR<							
	OR<>							
OR<=								
OR>=								
Data control instructions	LIMIT	Limits the output range of values						
	BAND	Define input offset						
	ZONE	Define output offset						
	SCL	Scale values					●	
	DABIN	Convert an ASCII number to a binary value						
	BINDA	Convert a binary value to ASCII code						
	SCL2	Scale values (different value table structure to SCL)						
Instructions for communication with frequency inverters	IVCK	Check status of frequency inverter						
	IVDR	Control frequency inverter						
	IVRD	Read frequency inverter parameter					●	
	IVWR	Write parameter to frequency inverter						
	IVBWR	Write parameters to frequency inverter in blocks						
Data exchange with special function modules	RBFM	Read from module buffer memory					●	
	WBFM	Write to module buffer memory					●	
High-speed counter instruction	HSCT	Compare current value of a high-speed counter with data in data tables					●	

Category	Instruction	Function	Controller				
			FX1S	FX1N	FX2N	FX2NC	FX3U
Instructions for extension file registers	LOADR	Read data from extension file registers					
	SAVER	Write data to extension file registers					
	INITR	Initialise extension registers and extension file registers					
	LOGR	Read values from devices in extension registers and extension file registers					●
	RWER	Write data from extension registers to extension file registers					
	INITER	Initialise extension file registers					

5.1.1 Entering applied instructions

Programming applied instructions in GX Developer FX is simple. Just position the cursor in the place in the program line where you want to insert the instruction and type the abbreviations for the instruction and its operand(s). GX Developer will automatically register that you are entering an instruction and will open the input dialog (see below). Alternatively, you can also position the cursor and then click on the insert instruction tool in the toolbar .

You can also select the instruction from the drop-down list, which you can display by clicking on the „▼“ icon.



Then enter the abbreviations for the instruction and its operand(s) in the input field, separating them by spaces.

All numbers must be preceded by a letter character, which either identifies the device type or – in the case of constants – specifies the number format. The letter “K” identifies decimal constants and “H” identifies hexadecimal constants.



In the example on the left a MOV instruction is used to write the value 5 to data register D12.

The **Help** button opens a dialog in which you can search for a suitable instruction for the function you want to perform. The help also contains information on how the functions work and the type and number of devices that they take as operands.

Then you just click on **OK** to insert the applied instruction into the program.

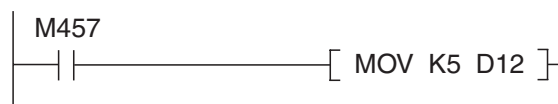

If you are programming in Instruction List format enter the instruction and its operand(s) in a single line, separated by spaces.

5.2 Instructions for Moving Data

The PLC uses data registers for storing measurements, output values, intermediate results of operations and table values. The controller’s math instructions can read their operands directly from the data registers and can also write their results back to the registers if you want. However, these instructions are also supported by additional “move” instructions, with which you can copy data from one register to another and write constant values to data registers.

5.2.1 Moving individual values with the MOV instruction

The MOV instruction “moves” data from the specified source to the specified destination.

NOTE | Note that despite its name this is actually a copy process – it does not delete the data from the source location.

Ladder Diagram

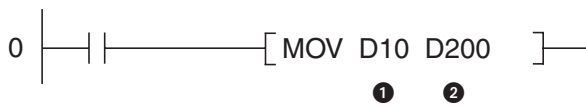

Instruction List



- ❶ Data source (this can also be a constant)
- ❷ Data destination

In the example the value in data register D10 will be copied to register D200 when input X1 is on. This results in the following signal sequence:

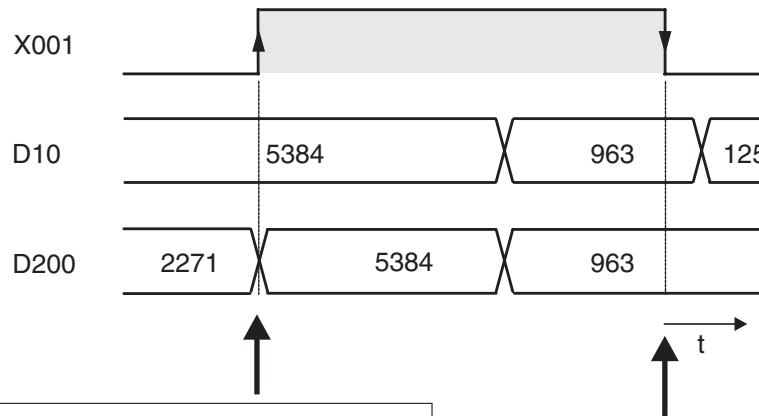

The contents of the data source will be copied to the data destination as long as the input condition evaluates true. The copy operation does not change the contents of the data source.

When the input condition is no longer true the instruction will no longer change the contents of the data destination.

Pulse-triggered execution of the MOV instruction

In some applications it is better if the value is written to the destination in one program cycle only. For example, you will want to do this if other instructions in the program also write to the same destination or if the move operation must be performed at a defined time.

If you add a “P” to the MOV instruction (MOVP) it will only be executed **once**, on the rising edge of the signal pulse generated by the input condition.

In the example below the contents of D20 are written to data register D387 when the state of M110 changes from "0" to "1".

Ladder Diagram

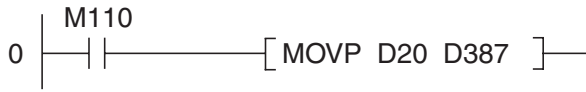

Instruction List

```
0 LD      M110
1 MOVP   D20  D387
```

After this single operation has been performed copying to register D387 stops, even if the M110 remains set. The signal sequence illustrates this:

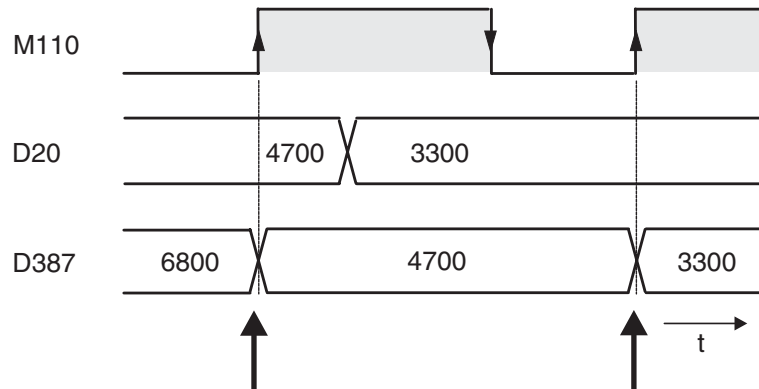

The contents of the data source are only copied to the destination on the rising pulse of the input condition.

Moving 32-bit data

To move 32-bit data just prefix a D to the MOV instruction (DMOV):

Ladder Diagram

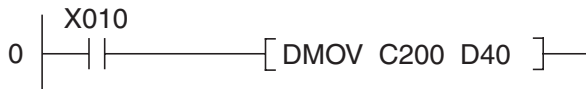

Instruction List

```
0 LD      X010
1 DMOV   C200  D40
```

When input X010 is on the current value of 32-bit counter C200 is written to data registers D40 and D41. D40 contains the least significant bits.

As you might expect, there is also a pulse-triggered version of the 32-bit DMOV instruction:

Ladder Diagram



Instruction List

```
0 LD      M10
1 DMOVP  D10  D610
```

When relay M10 is set the contents of registers D10 and D11 are written to registers D610 and D611.

5.2.2 Moving groups of bit devices

The previous section showed how you can use the MOV instruction to write constants or the contents of data registers to other data registers. Consecutive sequences of relays and other bit devices can also be used to store numerical values, and you can copy them as groups with applied instructions. To do this you prefixing a “K” factor to the address of the first bit device, specifying the number of devices you want to copy with the operation.

Bit devices are counted in groups of 4, so the K factor specifies the number of these groups of 4. K1 = 4 devices, K2 = 8 devices, K3 = 12 devices and so on.

For example, K2M0 specifies the 8 relays from M0 through M7. The supported range is K1 (4 devices) to K8 (32 devices).

Examples for addressing groups of bit devices:

- K1X0: 4 inputs, start at X0 (X0 to X3)
- K2X4: 8 inputs, start at X4 (X4 to X13, octal notation)
- K4M16: 16 relays, start at 16 (M16 to M31)
- K3Y0: 12 outputs, start at Y0 (Y0 to X13, octal notation)
- K8M0: 32 relays, start at M0 (M0 to M31)

Addressing multiple bit devices with a single instruction makes programming quicker and produces more compact programs. The following two examples both transfer the signal states of relays M0 – M4 to outputs Y10 – Y14:

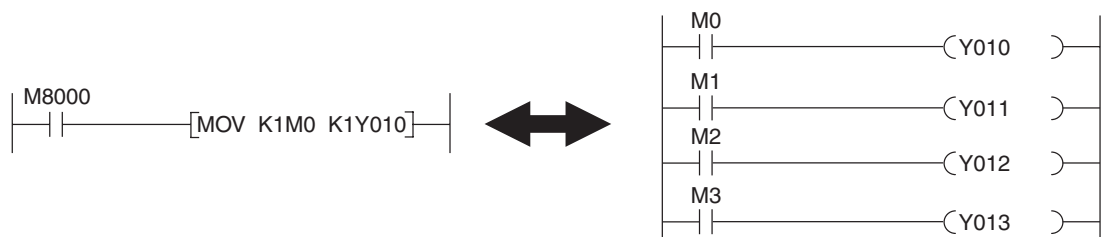

If the destination range is smaller than the source range the excess bits are simply ignored (see the following illustration, top example). If the destination is larger than the source “0” is written to the excess devices. Note that when this happens the result is always positive because bit 15 is interpreted as the sign bit (lower example in the following illustration).

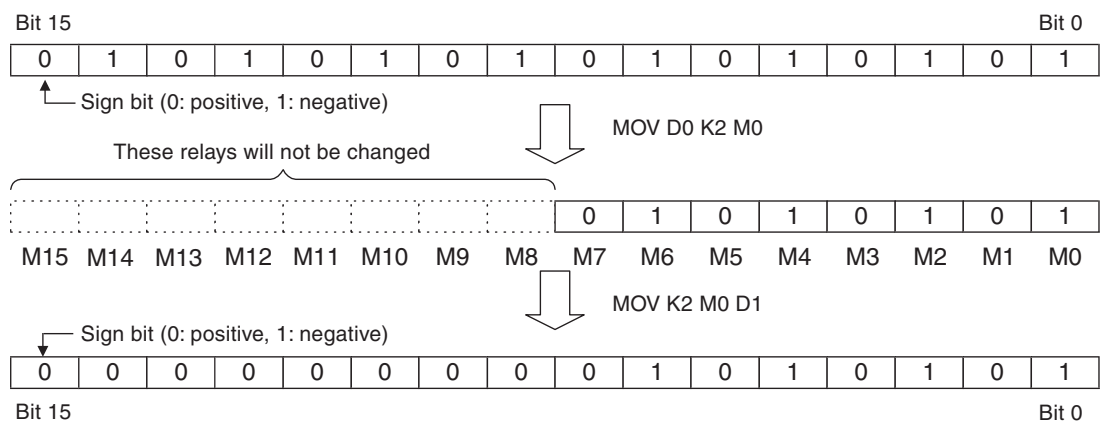

5.2.3 Moving blocks of data with the BMOV instruction

The MOV instruction described in Chapter 5.2.1 can only write single 16 or 32 bit values to a destination. If you want, you can program multiple sequences of MOV instructions to move contiguous blocks of data. However, it is more efficient to use the BMOV (Block MOVE) instruction, which is provided specifically for this purpose.

Ladder Diagram



Instruction List

0 BMOV D10 D200 K5
① ② ③

- ① Data source (16-bit device, first device in source range)
- ② Data destination (16-bit device, first device in destination range)
- ③ Number of elements to be moved (max. 512)

The example above works as follows:

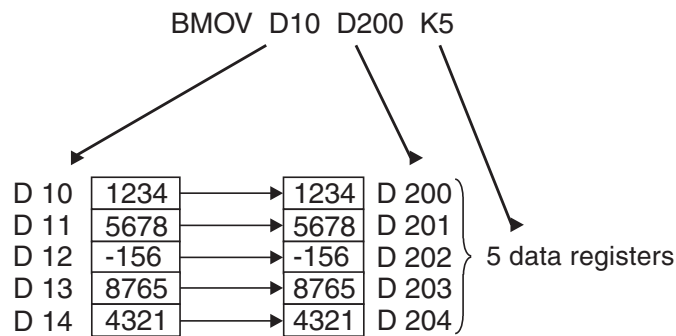

BMOV also has a pulse-triggered version, BMOVP (see section 5.2.1 for details on pulse-triggered execution).

Blocks of bit devices: When you move blocks of bit devices with BMOV the K factors of the data source and the data destination must always be identical.

Example

BMOV K1M0 K1Y0 K2

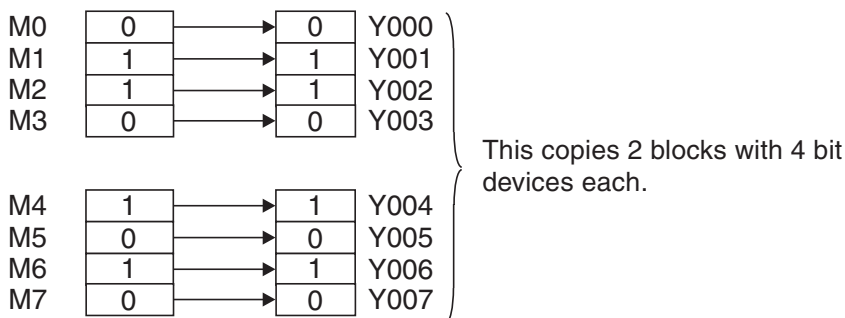

5.2.4 Copying source devices to multiple destinations (FMOV)

The FMOV (Fill MOVE) instruction copies the contents of a word or double word device or a constant to multiple consecutive word or double word devices. It is generally used to delete data tables and to set data registered to a predefined starting value.

Ladder Diagram



Instruction List



- ① Data to be written to the target devices (constants can also be used here)
- ② Data destination (first device of the destination range)
- ③ Number of elements to be written in the destination range (max. 512)

The following example writes the value “0” to 7 elements:

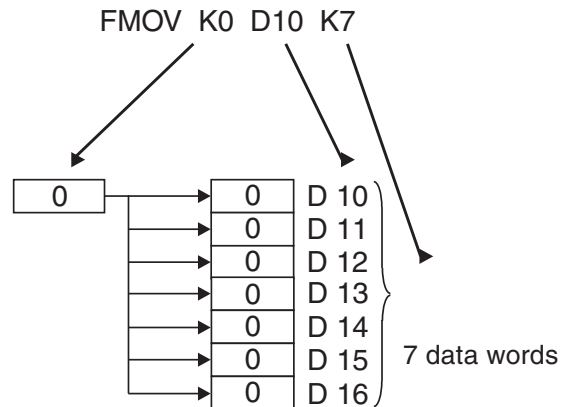

Here too, FMOV has a pulse-triggered version, FMOV_P (see section 5.2.1 for details on pulse-triggered execution).

You can also transfer 32-bit data by prefixing the instruction with “D” (DFMOV and DFMOV_P).

5.2.5 Exchanging data with special function modules

You can add expansion modules to increase the number of inputs and outputs available to all base units of the MELSEC FX series except the FX1S models. In addition to this you can also supplement the controller’s functions by adding so-called “special function modules” – for example for reading analog signals for currents and voltages, for controlling temperatures and for communicating with external equipment.

The digital I/O expansion modules do not require special instructions; the additional inputs and outputs are handled in exactly the same way as those in the base unit. Communication between the base unit and special function modules is performed with two special applied instructions: the FROM and TO instructions.

Each special function module has a memory range assigned as a buffer for temporary storage of data, such as analog measurement values or received data. The base unit can access this buffer and both read the stored values from it and write new values to it, which the module can then process (settings for the module’s functions, data for transmission etc).

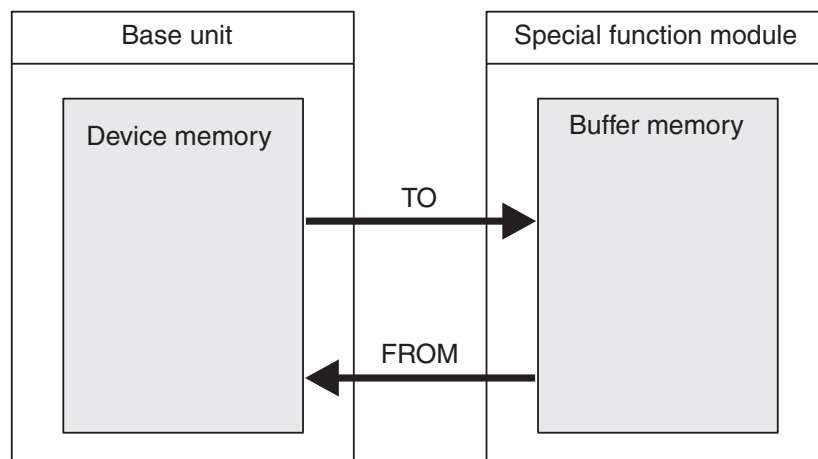

The buffer memory can have up to 32,767 individual addressable memory cells, each of which can store 16 bits of data. The functions of the buffer memory cells depends on the individual special function module – see the module’s documentation for details.

Buffer memory address 0
Buffer memory address 1
Buffer memory address 2
:
:
Buffer memory address n-1
Buffer memory address n

The following information is required when you use the FROM and TO instructions:

- The special function module to be read from or written to
- The address of the first buffer memory cell to be read from or written to
- The number of buffer memory cells to be read from or written to
- The location in the base unit where the data from the module is to be stored or containing the data to be written to the module

Special function module address

Since you can attach multiple special function modules to a single controller each module needs to have a unique identifier so that you can address it to transfer data to and from it. Each module is automatically assigned a numerical ID in the range from 0 – 7 (you can connect a maximum of 8 special function modules). The numbers are assigned consecutively, in the order in which the modules are connected to the PLC.

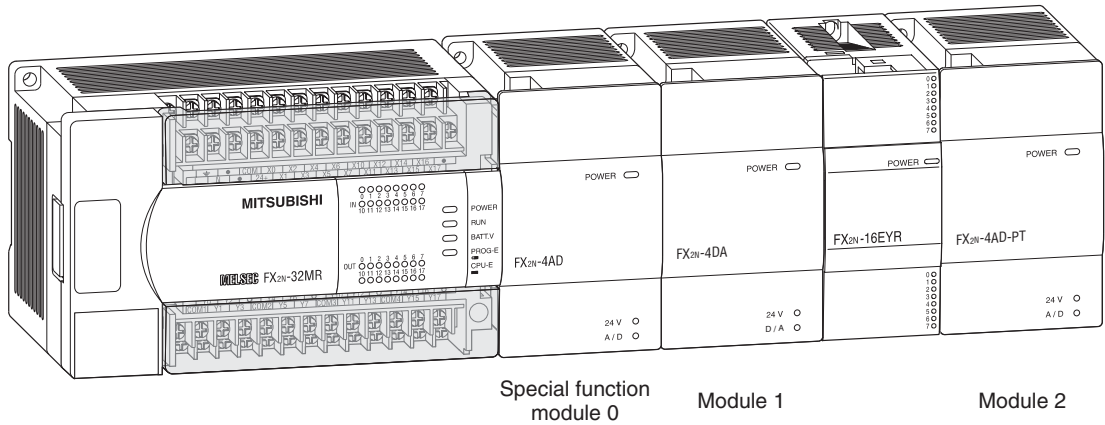

Starting address in the buffer memory

Every single one of the 32,767 buffer addresses can be addressed directly in decimal notation in the range from 0 – 32,767 (FX1N: 0 – 31). When you access 32-bit data you need to know that the memory cell with the lower address stores the less significant 16 bits and the cell with the higher address stores the more significant bits.

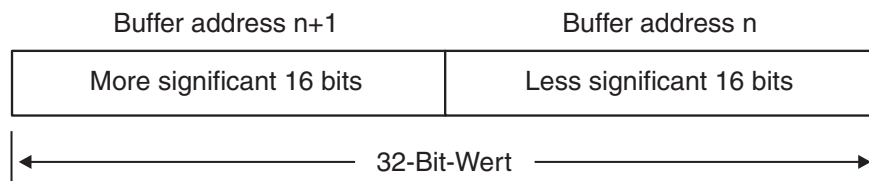

This means that the starting address for 32-bit data is always the address containing the less significant 16 bits of the double word.

Number of data units to be transferred

The quantity of data is defined by the number of data units to be transferred. When you execute a FROM or TO instruction as a 16-bit instruction this parameter is the number of words to be transferred. In the case of the 32-bit versions DFROM and DTO the parameter specifies the number of double words to be transferred.

16-bit instruction

Units of data: 5

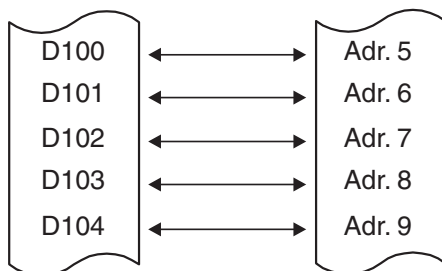

32-bit instruction

Units of data: 2

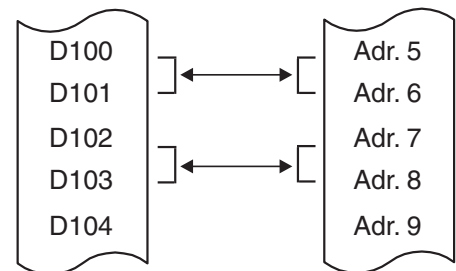

The value you can enter for the number of data units depends on the PLC model you are using and whether you are using the 16-bit or 32-bit version of the FROM instruction:

PLC Model	Valid range for no. of data units to be transferred	
	16-Bit Instruction (FROM, TO)	32-Bit Instruction (DFROM, DTO)
FX2N	1 bis 32	1 bis 16
FX2NC	1 bis 32	1 bis 16
FX3U	1 bis 32767	1 bis 16383

Data destination or source in the base unit

In most cases you will read data from registers and write it to a special function module, or copy data from the module's buffer to data registers in the base unit. However, you can also use outputs, relays and the current values of timers and counters as data sources and destinations.

Pulse-triggered execution of the instructions

If you add a P suffix to the instructions the data transfer is initiated by pulse trigger (for details see the description of the MOV instruction in section 5.2.1).

How to use the FROM instruction

The FROM instruction is used to transfer data from the buffer of a special function module to the controller base unit. Note that this is a copy operation – the contents of the data in the module buffer are not changed.

Ladder Diagram



Instruction List



- ① Special function module address (0 to 7)
- ② Starting address in buffer (FX1N: 0 – 31, FX2N, FX2NC and FX3U: 0 – 32,766). You can use a constant or a data register containing the value.
- ③ Data destination in the controller base unit
- ④ Number of data units to be transferred

The example above uses FROM to transfer data from an FX2N-4AD analog/digital converter module with the address 0. The instruction reads the current value of channel 1 from buffer address 9 and writes it to data register D0.

The next example shows how the 32-bit version of the instruction is used to read data from address 2 in the special function module. The instruction reads 4 double words starting at buffer address 8 and writes them to data registers D8 – D15.



The next example illustrates the use of the pulse triggered version, FROMP. Here the contents of the four buffer addresses 0 – 3 are only transferred to data registers D10 – D13 when the signal state of the input condition changes from “0” to “1”.



How to use the TO instruction

The TO instruction transfers data from the controller base unit to the buffer of a special function module. Note that this is a copy operation, it does not change the data in the source location.

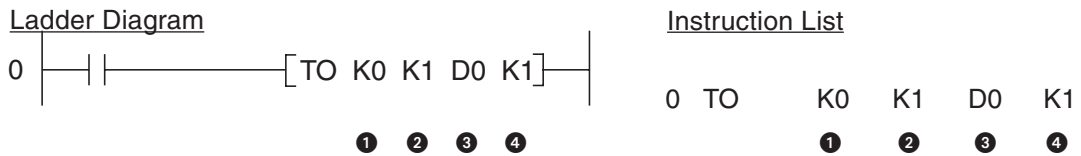

- ① Special function module address (0 – 7)
- ② Starting address in buffer (FX1N: 0 – 31, FX2N, FX2NC and FX3U: 0 – 32,766). You can use a constant or a data register containing the value.
- ③ Data source in the controller base unit
- ④ Number of data units to be transferred

In the example above the contents of data register D0 are copied to the buffer address 1 of special function module number 0.

5.3 Compare Instructions

Checking the status of bit devices like inputs and relays can be achieved with basic logic instructions because these devices can only have two states, “0” and “1”. However, you will also often want to check the contents of word devices before doing something – for example switching on a cooling fan when a specified setpoint temperature is exceeded. The controllers of the MELSEC FX family provide a number of different ways to compare data.

5.3.1 The CMP instruction

CMP compares two numerical values, which can be constants or the contents of data registers. You can also compare the current values of timers and counters. Depending on the result of the comparison (greater than, less than or equal) one of three bit devices is set.

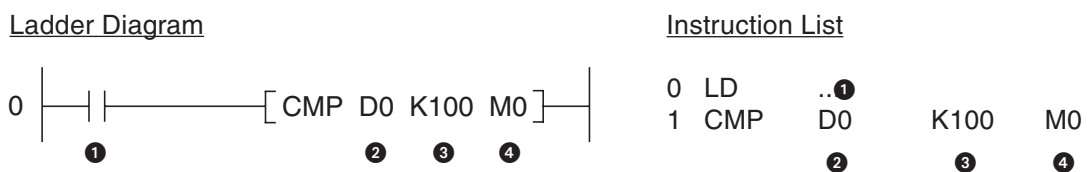

- ① Input condition
- ② First value to be compared
- ③ Second value to be compared
- ④ First of three consecutive relays or outputs, which are set (signal status “1”) depending on the result of the comparison:
 - 1. Device 1: ON if Value 1 > Value 2
 - 2. Device 2: ON if Value 1 = Value 2
 - 3. Device 3: ON if Value 1 < Value 2

In this example the CMP instruction controls relays M0, M1 and M2. M0 is “1” if the contents of D0 is greater than 100; M1 is “1” if the contents of D0 is precisely 100 and M2 is “1” if D0 is less than 100. The state of the three bit devices is maintained even after the input condition has been switched off because their last state is stored.

To compare 32-bit data you just use DCMP instead of CMP:

Ladder Diagram

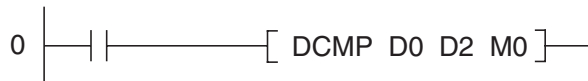

Instruction List

```

0 LD      ....
1 DCMP   D0      D2      M0
    
```

In the example above the contents of D0 and D1 are compared with the contents of D2 and D3. The handling of the three bit devices indicating the result of the comparison is exactly the same as for the 16-bit version of the instruction.

Application example

It is easy to create a two-point control loop with the CMP instruction:

Ladder Diagram

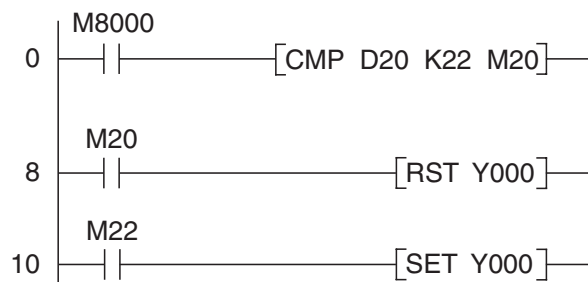

Instruction List

```

0 LD      M8000
1 CMP     D20      K22      M20
8 LD      M20
9 RST     Y000
10 LD     M22
11 SET    Y0001
    
```

In this example the CMP instruction is executed cyclically. M8000 is always “1” when the PLC is executing the program. Register D20 contains the value for the current room temperature. Constant K22 contains the setpoint value of 22°C. Relays M20 and M22 show when the temperature goes higher or lower than the setpoint. If the room is too warm output Y0 is switched off. If the temperature is too low M22 switches output Y0 on again. This output could be used to control a pump for adding hot water, for example.

5.3.2 Comparisons within logic operations

In the CMP instruction described in the last section the result of the comparison is stored in three bit devices. Often, however, you only want to execute an output instruction or a logic operation on the basis of the result of a comparison, and you generally won't want to have to use three bit devices for this. You can achieve this with the "load compare" instructions and the AND and OR bitwise logic comparisons.

Comparison at the beginning of a logic operation

Ladder Diagram



Instruction List



- ❶ Compare condition
- ❷ First compare value
- ❸ Second compare value

If the condition evaluates true the signal state after the comparison is set to "1". A signal state of "0" shows that the comparison evaluated as false. The following comparisons are possible:

- Compare for "equals": = (value 1 = value 2)
The output of the instruction is only set to "1" if the values of both devices are identical.
- Compare for "greater than": > (value 1 > value 2)
The output of the instruction is only set to "1" if the first value is greater than the second value.
- Compare for "less than": < (value 1 < value 2)
The output of the instruction is only set to "1" if the first value is smaller than the second value.
- Compare for "not equal": <> (value 1 <> value 2)
The output of the instruction is only set to "1" if the two values are not equal.
- Compare for "less than or equal to": <= (value 1 ≤ value 2)
The output of the instruction is only set to "1" if the first value is less than or equal to the second value.
- Compare for "greater than or equal to": >= (value 1 ≥ value 2)
The output of the instruction is only set to "1" if the first value is greater than or equal to the second value.

To compare 32-bit data prefix a D (for double word) to the compare condition:

Ladder Diagram

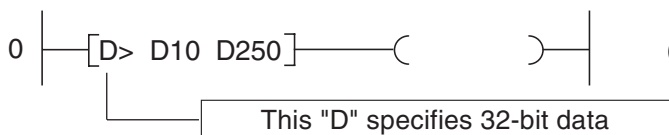

Instruction List



The example above checks whether the contents of data registers D10 and D11 are greater than the contents of registers D250 and D251.

More examples:

Ladder Diagram

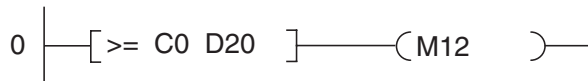

Instruction List

```
0 LD>= C0 D20
5 OUT M12
```

Relay M12 is set to "1" when the value of counter C0 is equal to or greater than the contents of D20.

Ladder Diagram

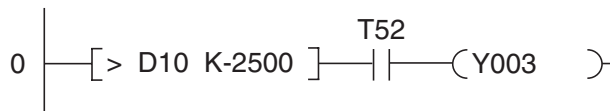

Instruction List

```
0 LD> D10 K-2500
5 AND T52
6 OUT Y003
```

Output Y003 is switched on when the contents of D10 is greater than -2,500 and timer T52 has finished running.

Ladder Diagram

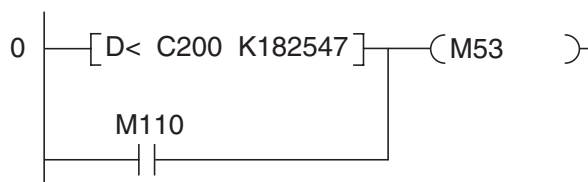

Instruction List

```
0 LDD< C200 K182547
9 OR M110
10 OUT M53
```

Relay M53 is set to "1" if either the value of counter C200 is less than 182,547 or relay M110 is set to "1".

Compare as a logical AND operation

Ladder Diagram

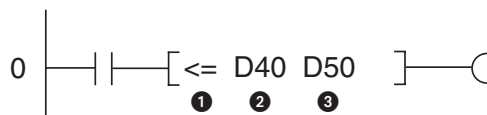

Instruction List

```
0 LD ...
1 AND<= D40 D50
```

- ① Compare condition
- ② First comparison value
- ③ Second comparison value

An AND comparison can be used just like a normal AND instruction (see chapter 3).

The comparison options are the same as those described above for a comparison at the beginning of an operation. Here too, you can also compare 32-bit values with an AND operation:

Ladder Diagram

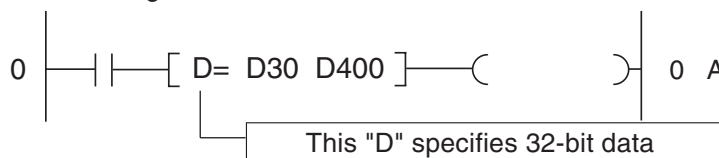

Instruction List

```
0 ANDD= D30 D400
```

Compare as a logical OR operation

Ladder Diagram

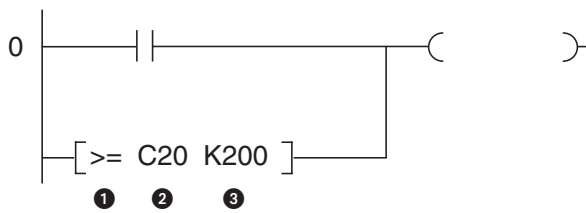

Instruction List

```

0 LD      ...
1 OR>=   C20   K200
          ①     ②     ③
    
```

- ① Compare condition
- ② First comparison value
- ③ Second comparison value

An OR comparison can be used just like a normal AND instruction (see chapter 3).

The comparison options are the same as those described above for a comparison at the beginning of an operation. Here too, you can also compare 32-bit values with an OR operation:

Ladder Diagram

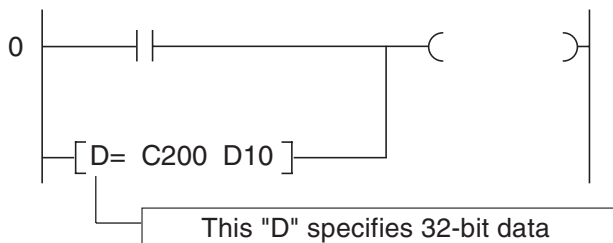

Instruction List

```

0 LD      ...
1 ORD=   C200   D10
    
```

5.4 Math Instructions

All the controllers of the MELSEC FX family can perform all four basic arithmetical operations and can add, subtract, multiply and divide integer numbers (i.e. non-floating-point numbers). These instructions are described in this section.

The controller base units of the FX2N, FX2NC and FX3U series can also process floating-point numbers. This is done with special instructions that are documented in detail in the Programming Manual of the MELSEC FX series.

After every addition or subtraction you should always program instructions to check the states of the special relays listed below to see whether the result is 0 or has exceeded the permitted value range.

- M8020

This special relay is set to "1" if the result of an addition or subtraction is 0.

- M8021

Special relay M8021 is set to "1" if the result of an addition or subtraction is smaller than -32,767 (16-bit operations) or -2,147,483,648 (32-bit operations).

- M8022

Special relay M8022 is set to "1" if the result of an addition or subtraction is greater than +32,767 (16-bit operations) or +2,147,483,647 (32-bit operations).

These special relays can be used as enable flags for continuing with additional math operations. In the following example the result of the subtraction operation in D2 is used as a divisor. Since dividing by 0 is impossible and causes an error the division is only executed if the divisor is not 0.

Ladder Diagram

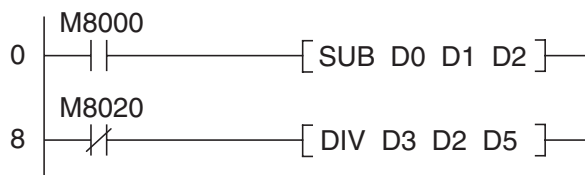

Instruction List

0	LD	M8000		
1	SUB	D0	D1	D2
8	LDI	M8020		
9	DIV	D3	D2	D5

5.4.1 Addition

The ADD instruction calculates the sum of two 16-bit or 32-bit values and writes the result to another device.

Ladder Diagram

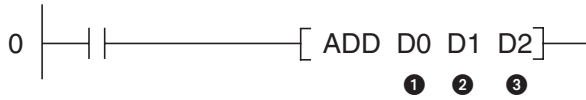

Instruction List

```
0 ADD    D0    D1    D2
      ①    ②    ③
```

- ① First source device or constant
- ② Second source device or constant
- ③ Device in which the result of the addition is stored

The example above adds the contents of D0 and D1 and writes the result to D2.

Examples

Add 1,000 to the contents of data register D100:



The signs of the values are taken into account by the ADD instruction:



You can also add 32-bit values by prefixing a "D" to the ADD instruction (DADD):

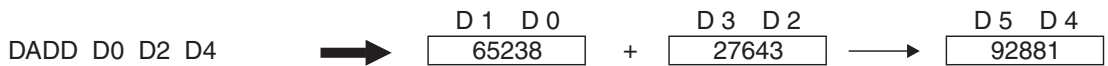

If you want you can also write the result to one of the source devices. However, if you do this remember that the result will then change in every program cycle if the ADD instruction is executed cyclically!



The ADD instruction can also be executed in pulse-triggered mode. Then it is only executed when the signal state of the input condition changes from "0" to "1". To use this mode just add a "P" suffix to the ADD instructions (ADDP, DADDP).

In the following example the constant value 27 is only added to the contents of D47 once, in the program cycle in which the signal state of relay M47 changes from "0" to "1":

Ladder Diagram



Instruction List

```
0 LD    M47
1 ADDP  D47  K27  D51
```

5.4.2 Subtraction

The SUB instruction calculates the difference between two numerical values (contents of 16-bit or 32-bit devices or constants). The result of the subtraction is written to a third device.

Ladder Diagram

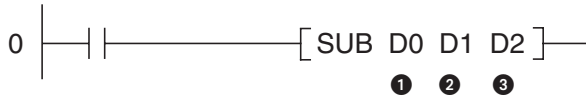

Instruction List

0 SUB D0 D1 D2
① ② ③

- ① Minuend (the subtrahend is subtracted from this value)
- ② Subtrahend (this value is subtracted from the minuend)
- ③ Difference (result of the subtraction)

In the example above the contents of D1 is subtracted from the contents of D0 and the difference is written to D2.

Examples

Subtract 100 from the contents of data register D11 and write the result to D101:



The signs of the values are taken into account by the SUB instruction:



You can also subtract 32-bit values by prefixing a "D" to the SUB instruction (DSUB):

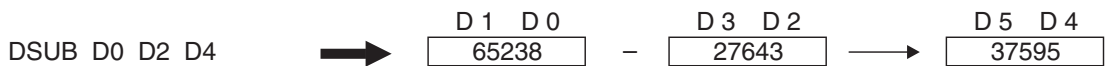

If you want you can also write the result to one of the source devices. However, if you do this remember that the result will then change in every program cycle if the SUB instruction is executed cyclically!



The SUB instruction can also be executed in pulse-triggered mode. Then it is only executed when the signal state of the input condition changes from "0" to "1". To use this mode just add a "P" suffix to the SUB instructions (SUBP, DSUBP).

In the following example the contents of D394 is only subtracted from contents of D50 once, in the program cycle in which the signal state of relay M50 changes from "0" to "1":

Ladder Diagram

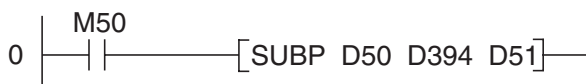

Instruction List

0 LD M50
 1 SUBP D50 D394 D51

5.4.3 Multiplication

The FX controllers' MUL instruction multiplies two 16-bit or 32-bit values and writes the result to a third device.

Ladder Diagram

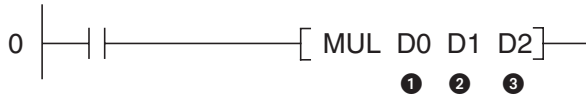

Instruction List

```
0 MUL D0 D1 D2
```

① ② ③

- ① Multiplicand
- ② Multiplier
- ③ Device in which the result of the addition is stored

The example above adds the contents of D0 and D1 and writes the result to D2.

NOTE

When you multiply two 16-bit values the result can quite easily exceed the range that can be displayed with 16 bits. Because of this the product of multiplications is always written to two consecutive 16-bit devices (i.e. a 32-bit double word).

When you multiply two 32-bit values the product is written to four consecutive 16-bit devices (64 bits, two double words).

Always take the size of these device ranges into account when you are programming and take care not to create range overlaps by using the devices in the ranges to which the products are written!

Examples

Multiply the contents of D0 and D1 and store the product in D3 and D2:

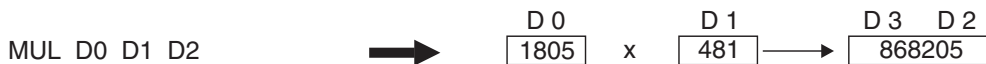

The signs of the values are taken into account by the MUL instruction. In this example the value in D10 is multiplied by the constant value -5:

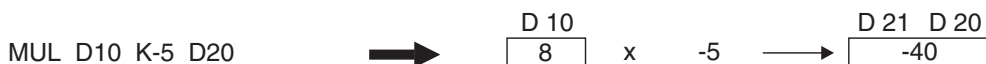

You can also multiply 32-bit values by prefixing a "D" to the MUL instruction (DMUL):

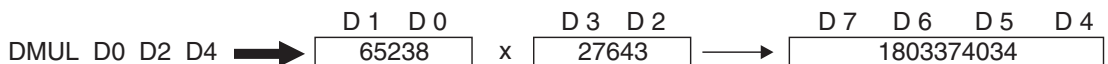

The MUL instruction can also be executed in pulse-triggered mode by adding a "P" suffix to the MUL instructions (MULP, DMULP). The following multiplication is only executed when input X24 switches from "0" to "1":

Ladder Diagram



Instruction List

```
0 LD X24
1 MULP D25 D300 D26
```

5.4.4 Division

The MELSEC FX family's DIV instruction divides one number by another (contents of two 16-bit or 32-bit devices or constants). This is an integer operation and cannot process floating-point values. The result is always an integer and the remainder is stored separately.

Ladder Diagram

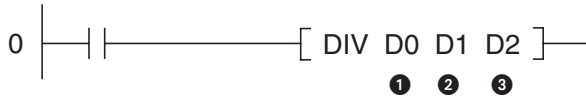

Instruction List



- ① Dividend
- ② Divisor
- ③ Quotient (result of the division, dividend ÷ divisor = quotient)

NOTES

The divisor should never be 0. Division by 0 is not possible and will generate an error.

When two 16-bit values are divided the quotient is written to one 16-bit device and the remainder is written to the next device. This means that the result of a division always requires two consecutive 16-bit devices (= 32 bits).

When you divide two 32-bit values the quotient is written to two 16-bit devices and the remainder is written to the next two 16-bit devices. This means that four consecutive 16-bit devices are always required for the result of a 32-bit division.

Always take the size of these device ranges into account when you are programming and take care not to create range overlaps by using the devices in the ranges to which the results of the calculations are written!

Examples

Divide the contents of D0 by the contents of D1 and write the result to D2 and D3:

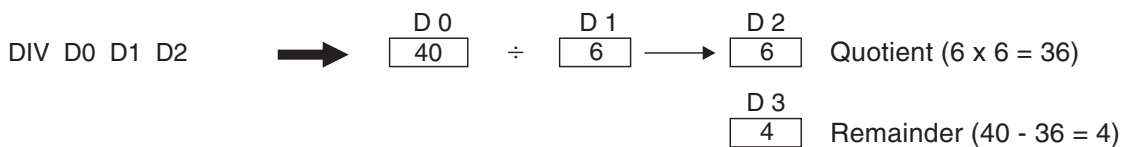

The signs of the values are taken into account by the DIV instruction. In this example the counter value of C0 is divided by the value in D10:

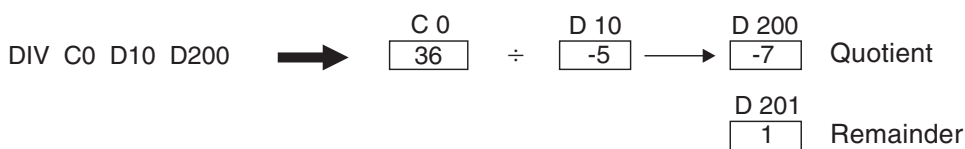

Division with 32-bit values:

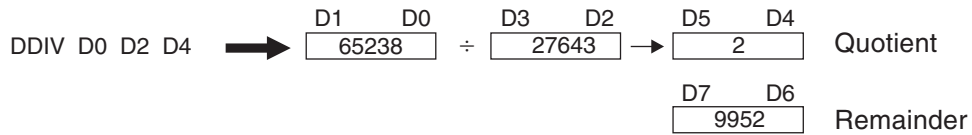

Adding a “P” suffix to the DIV instructions executes the instructions in pulse-triggered mode (DIV -> DIVP, DDIVPL -> DMULP). In the following example the counter value of C12 is only divided by 4 in the program cycle in which input X30 is switched on:

Ladder Diagram

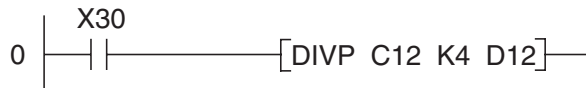

Instruction List

```
0 LD X30
1 DIVP C12 K4 D12
```

5.4.5 Combining math instructions

In real life one calculation is seldom all you want to perform. The FX controllers allow you to combine math instructions to solve more complex calculations. Depending on the nature of the calculation you may have to use additional devices to store intermediate results.

The following example shows how you could calculate the sum of the values in data registers D101, D102 and D103 and then multiply the result by the factor 4:

Ladder Diagram

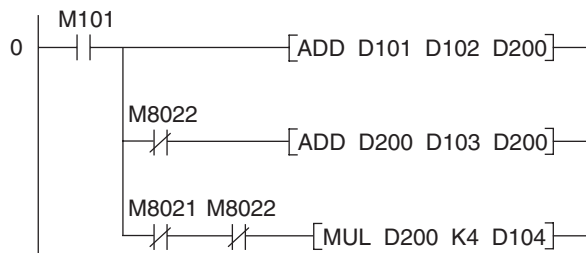

Instruction List

```
0 LD M101
1 ADD D101 D102 D200
8 MPS
9 ANI M8022
10 ADD D200 D103 D200
17 MPP
18 ANI M8021
19 ANI M8022
20 MUL D200 K4 D104
```

- First the contents of D101 and D102 are added and the result is stored in D200.
- If (and only if) the sum of D101 and D102 does not exceed the permitted range it is then added to the value in D103.
- If the sum of D101 through D103 does not exceed the permitted range it is multiplied by the factor 4 and the result is written to D104 and D105.

6 Expansion Options

6.1 Introduction

You can expand the base units of the MELSEC FX series with expansion modules and special function modules.

These modules are divided into three categories:

- Modules that occupy digital inputs and outputs (installed on the right of the controller). These include the compact and modular digital expansion and special function modules.
- Modules that do not occupy any digital inputs and outputs (installed on the left side of the controller).
- Interface and communications adapters that do not occupy any digital inputs and outputs (installed directly in the controller unit).

6.2 Available Modules

6.2.1 Modules for adding more digital inputs and outputs

A variety of different modular and compact expansion modules are available for adding I/Os to the MELSEC FX1N/FX2N/FX2NC and FX3U base units. In addition to this, digital I/Os can also be added to the controllers of the FX1S, FX1N and FX3U series with special expansion adapters that are installed directly in the controller itself. These adapters are a particularly good choice when you only need a few additional I/Os and/or do not have enough space to install expansion modules on the side of the controller.

The "modular" expansion units only contain the digital inputs and outputs, they do not have their own power supplies. The "compact" expansion units have a larger number of I/Os and an integrated power supply unit for the system bus and the digital inputs.

The available base units and expansion units can be mixed and matched in a huge variety of different combinations, making it possible to configure your controller system very precisely to the needs of your application.

6.2.2 Analog I/O modules

Analog I/O modules convert analog input signals to digital values or digital input signals to analog signals.

A number of modules are available for current/voltage signals and for temperature monitoring with direct connections for Pt100 resistance thermometers or thermo elements.

6.2.3 Communications modules

Mitsubishi Electric produces a range of interface modules and adapters with serial ports (RS-232, RS-422 and RS-485) for connecting peripherals or other controllers.

A number of special communications modules are available for integrating the MELSEC FX1N, FX2N, FX2NC and FX3U in a variety of different networks.

ENetwork interface modules are currently available for Profibus/DP, AS-interface, DeviceNet, CANopen, CC-Link and Mitsubishi's own proprietary networks.

6.2.4 Positioning modules

You can complement the internal high-speed counters of the MELSEC FX controllers with additional external hardware high-speed counter modules, which you can use for connecting devices like incremental rotary transducers and positioning modules for servo and stepping drive systems.

You can program precise positioning applications with the MELSEC FX family with the help of positioning modules for pulse train generation. These modules can be used to control both stepping and servo drives.

6.2.5 HMI control and display panels

Mitsubishi Electric's control and display panels provide an effective and user-friendly human-machine interface (HMI) for working with the MELSEC FX series. HMI control units make the functions of the controlled application transparent and comprehensible.

All the available units can monitor and edit all relevant PLC parameters, such as actual and setpoint values for times, counters, data registers and sequential instructions.

HMI units are available with both text and graphics based displays. Fully-programmable function keys and touch-sensitive screens make them even easier to use. The units are programmed and configured with a Windows®-based PC running user-friendly software.

The HMI units communicate with the FX PLCs via the programming interface, and they are connected directly with their standard cable. No additional modules are required to connect the units to the PLCs.

Index

A

ADD instruction	5-21
ANB instruction	3-12
AND instruction	3-9
ANDP/ANDF instruction	3-14
ANI instruction	3-9
Automatic shutdown	3-22

B

Binary numbers	3-2
BMOV instruction	5-10
Buffer memory	5-12

C

Counter	
Functions	4-7
Specifying setpoints indirectly	4-11

D

Data registers	4-9
Device	
Address	3-1
Counter overview	4-8
Data register overview	4-10
File registers overview	4-11
Inputs/outputs overview	4-2
Name	3-1
Relay overview	4-3
Timer overview	4-6
DIV instruction	5-24

E

EEPROM	2-9
Emergency OFF devices	3-21
Example of programming	
A rolling shutter gate	3-28
An alarm system	3-23
Clock signal generator	4-16
Delay switches	4-4
Specifying timer and counter setpoints	4-11
Switch-off delay	4-14

F

Falling edge	3-14
FMOV instruction	5-11
FROM instruction	5-14

H

Hexadecimal numbers	3-3
-------------------------------	-----

I

Instruction	
ADD	5-21
ANB	3-12
AND	3-9
ANDF	3-14
ANDP	3-14
ANI	3-9
BMOV	5-10
CMP	5-15
DIV	5-24
FMOV	5-11
FROM	5-14
INV	3-20
LD	3-6
LDF	3-14
LDI	3-6
LDP	3-14
MC	3-19
MCR	3-19
MOV	5-7
MPP	3-17
MPS	3-17
MRD	3-17
MUL	5-23
OR	3-11
ORB	3-12
ORF	3-14
ORI	3-11
ORP	3-14
OUT	3-6
PLF	3-18
PLS	3-18
RST	3-15
SET	3-15
SUB	5-22
TO	5-15
Interlock contacts	3-21
INV instruction	3-20

L

LD instruction	3-6
LDI Instruction	3-6
LDP/LDF instruction	3-14

M

Memory battery	2-9
MOV instruction	5-7
MPP instruction	3-17
MPS instruction	3-17
MRD instruction	3-17
MUL instruction	5-23

O

Octal numbers	3-4
Optical couplers	2-6
OR instruction	3-11
ORB instruction	3-12
ORI instruction	3-11
ORP/ORF instruction	3-14
OUT Instruction	3-6

P

PLF instruction	3-18
PLS instruction	3-18
Process image processing	2-2
Program instruction	3-1

R

Retentive timers	4-5
Rising edge	3-14
RST instruction	3-15
RUN/STOP switch	2-9

S

Safety cable breaks	3-21
Service power supply	2-9
SET instruction	3-15
Signal feedback	3-22
Special function modules	
Exchanging data with special function modules	5-12
Special registers	4-10
Special relays	4-3
SUB instruction	5-22
Switch-off delay	4-14

T

Timers	4-4
TO instruction	5-15

HEADQUARTERS	EUROPÄISCHE VERTRETUNGEN	EUROPÄISCHE VERTRETUNGEN	VERTRETUNGEN EURASIEN
MITSUBISHI ELECTRIC EUROPE B.V. German Branch Gothaer Straße 8 D-40880 Ratingen Telefon: 02102 / 486-0 Telefax: 02102 / 486-1120 E-Mail: megfamail@meg.mee.com MITSUBISHI ELECTRIC EUROPE B.V. French Branch 25, Boulevard des Bouverts F-92741 Nanterre Cedex Telefon: +33 1 55 68 55 68 Telefax: +33 1 55 68 56 85 E-Mail: factoryautomation@framee.com MITSUBISHI ELECTRIC EUROPE B.V. Irish Branch Westgate Business Park, Ballymount IRL-Dublin 24 Telefon: +353 (0) 1 / 419 88 00 Fax: +353 (0) 1 / 419 88 90 E-Mail: sales.info@meir.mee.com MITSUBISHI ELECTRIC EUROPE B.V. Italian Branch Via Paracelso 12 I-20041 Agrate Brianza (MI) Telefon: +39 039 6053 1 Telefax: +39 039 6053 312 E-Mail: factoryautomation@it.mee.com MITSUBISHI ELECTRIC EUROPE B.V. Spanish Branch Carretera de Rubí 76-80 E-08190 Sant Cugat del Vallés Telefon: +34 9 3 / 565 3160 Telefax: +34 9 3 / 589 1579 E-Mail: industrial@sp.mee.com MITSUBISHI ELECTRIC EUROPE B.V. UK Branch Travellers Lane GB-Hatfield Herts. AL10 8 XB Telefon: +44 (0) 1707 / 27 61 00 Telefax: +44 (0) 1707 / 27 86 95 E-Mail: automation@meuk.mee.com MITSUBISHI ELECTRIC CORPORATION Office Tower "Z" 14 F 8-12, 1 chome, Harumi Chuo-Ku Tokyo 104-6212 Telefon: +81 3 6221 6060 Telefax: +81 3 6221 6075 MITSUBISHI ELECTRIC AUTOMATION 500 Corporate Woods Parkway Vernon Hills, IL 60061 Telefon: +1 847 / 478 21 00 Telefax: +1 847 / 478 22 83	Koning & Hartman B.V. BELGIEN Researchpark Zellik, Pontbeeklaan 43 BE-1731 Brussels Telefon: +32 (0)2 / 467 17 44 Telefax: +32 (0)2 / 467 17 48 E-Mail: info@koningenhartman.com TELECON CO. BULGARIEN Andrej Ljapchev Lbv. Pb 21 4 BG-1756 Sofia Telefon: +359 (0) 2 / 97 44 05 8 Telefax: +359 (0) 2 / 97 44 06 1 E-Mail: — louis poulsen industri & automation DÄNEMARK Geminivej 32 DK-2670 Greve Telefon: +45 (0) 70 / 10 15 35 Telefax: +45 (0) 43 / 95 95 91 E-Mail: lpia@lpmail.com UTU Elektrotehnika AS ESTLAND Pärnu mnt.160i EE-11317 Tallinn Telefon: +372 (0) 6 / 51 72 80 Telefax: +372 (0) 6 / 51 72 88 E-Mail: utu@utu.ee Beijer Electronics OY FINNLAND Ansatie 6a FI-01740 Vantaa Telefon: +358 (0) 9 / 886 77 500 Telefax: +358 (0) 9 / 886 77 555 E-Mail: info@beijer.fi UTECO A.B.E.E. GRIECHENLAND 5, Mavrogenous Str. GR-18542 Piraeus Telefon: +302 (0) 10 / 42 10 050 Telefax: +302 (0) 10 / 42 12 033 E-Mail: sales@uteco.gr SIA POWEL LETTLAND Lienes iela 28 LV-1009 Riga Telefon: +371 784 / 2280 Telefax: +371 784 / 2281 E-Mail: utu@utu.lv UAB UTU POWEL LITAUEN Savanoriu pr. 187 LT-2053 Vilnius Telefon: +370 (0) 52323-101 Telefax: +370 (0) 52322-980 E-Mail: powel@utu.lt Intehsis srl MOLDAWIEN Cuza-Voda 36/1-81 MD-2061 Chisinau Telefon: +373 (0)2 / 562263 Telefax: +373 (0)2 / 562263 E-Mail: intehsis@mdl.net Koning & Hartman B.V. NIEDERLANDE Donauweg 2 B NL-1000 AK Amsterdam Telefon: +31 (0)20 / 587 76 00 Telefax: +31 (0)20 / 587 76 05 E-Mail: info@koningenhartman.com Beijer Electronics A/S NORWEGEN Teglverksveien 1 N-3002 Drammen Telefon: +47 (0) 32 / 24 30 00 Telefax: +47 (0) 32 / 84 85 77 E-Mail: info@beijer.no GEVA ÖSTERREICH Wiener Straße 89 AT-2500 Baden Telefon: +43 (0) 2252 / 85 55 20 Telefax: +43 (0) 2252 / 488 60 E-Mail: office@geva.at MPL Technology Sp. z o.o. POLEN ul. Sliczna 36 PL-31-444 Kraków Telefon: +48 (0) 12 / 632 28 85 Telefax: +48 (0) 12 / 632 47 82 E-Mail: krakow@mpl.pl	Sirius Trading & Services srl RUMÄNIEN Str. Biharia Nr. 67-77 RO-013981 Bucuresti 1 Telefon: +40 (0) 21 / 201 1146 Telefax: +40 (0) 21 / 201 1148 E-Mail: sirius@siriustrading.ro Beijer Electronics AB SCHWEDEN Box 426 S-20124 Malmö Telefon: +46 (0) 40 / 35 86 00 Telefax: +46 (0) 40 / 35 86 02 E-Mail: info@beijer.se ECONOTEC AG SCHWEIZ Postfach 282 CH-8309 Nürensdorf Telefon: +41 (0) 1 / 838 48 11 Telefax: +41 (0) 1 / 838 48 12 E-Mail: info@econotec.ch AutoCont Control s.r.o. SLOWAKEI Radlinského 47 SK-02601 Dolný Kubín Telefon: +421 435868 210 Telefax: +421 435868 210 E-Mail: info@autocontcontrol.sk INEA d.o.o. SLOWENIEN Stegne 11 SI-1000 Ljubljana Telefon: +386 (0) 1-513 8100 Telefax: +386 (0) 1-513 8170 E-Mail: inea@inea.si AutoCont Control Systems s.r.o. TSCHECHISCHE REPUBLIK Nemocnici 12 CZ-702 00 Ostrava 2 Telefon: +420 59 / 6152 111 Telefax: +420 59 / 6152 562 E-Mail: consys@autocont.cz GTS TÜRKEI Darülaceze Cad. No. 43 Kat. 2 TR-80270 Okmeydani-Istanbul Telefon: +90 (0) 212 / 320 1640 Telefax: +90 (0) 212 / 320 1649 E-Mail: gts@turk.net CSC Automation Ltd. UKRAINE 15, M. Raskova St., Fl. 10, Office 1010 UA-02002 Kiev Telefon: +380 (0) 44 / 494 33 55 Telefax: +380 (0) 44 / 494 33 66 E-Mail: csc-a@csc-a.kiev.ua Meltrade Ltd. UNGARN Fertő Utca 14. HU-1107 Budapest Telefon: +36 (0)1 / 431-9726 Telefax: +36 (0)1 / 431-9727 E-Mail: office@meltrade.hu Tehnikon WEISSRUSSLAND Oktjabskaya 16/5, Ap 704 BY-220030 Minsk Telefon: +375 (0) 17 / 210 46 26 Telefax: +375 (0) 17 / 210 46 26 E-Mail: tehnikon@belsonet.net	Kazpromautomatics Ltd. KASACHSTAN 2, Scladskaya Str. KAZ-470046 Karaganda Telefon: +7 3212 50 11 50 Telefax: +7 3212 50 11 50 E-Mail: info@kpakz.com Avtomatika Sever Ltd. RUSSLAND Lva Tolstogo Str. 7, Off. 311 RU-197376 St Petersburg Telefon: +7 812 1183 238 Telefax: +7 812 1183 239 E-Mail: as@avtsev.spb.ru Consys Promyshlennaya St. 42 RUSSLAND RU-198099 St Petersburg Telefon: +7 812 325 3653 Telefax: +7 812 147 2055 E-Mail: consys@consys.spb.ru Electrotechnical Systems Siberia RUSSLAND Shetinkina St. 33, Office 116 RU-630088 Novosibirsk Telefon: +7 3832 / 119598 Telefax: +7 3832 / 119598 E-Mail: info@eltechsystems.ru Elektrostyle RUSSLAND Poslannikov Per., 9, Str. 1 RU-107005 Moscow Telefon: +7 095 542 4323 Telefax: +7 095 956 7526 E-Mail: info@estl.ru Elektrostyle RUSSLAND Krasnjij Prospekt 220-1, Office No. 312 RU-630049 Novosibirsk Telefon: +7 3832 / 106618 Telefax: +7 3832 / 106626 E-Mail: info@estl.ru ICOS RUSSLAND Industrial Computer Systems Zao Ryazanskij Prospekt, 8A, Off. 100 RU-109428 Moscow Telefon: +7 095 232 0207 Telefax: +7 095 232 0327 E-Mail: mail@icos.ru NPP Uralelektra RUSSLAND Sverdlova 11A RU-620027 Ekaterinburg Telefon: +7 34 32 / 532745 Telefax: +7 34 32 / 532745 E-Mail: elektra@etel.ru STC Drive Technique RUSSLAND Poslannikov Per., 9, Str. 1 RU-107005 Moscow Telefon: +7 095 790 7210 Telefax: +7 095 790 7212 E-Mail: info@privod.ru
KUNDEN-TECHNOLOGIE-CENTER DEUTSCHLAND MITSUBISHI ELECTRIC EUROPE B.V. Kunden-Technologie-Center Nord Revierstraße 5 D-44379 Dortmund Telefon: (02 31) 96 70 41-0 Telefax: (02 31) 96 70 41-41 MITSUBISHI ELECTRIC EUROPE B.V. Kunden-Technologie-Center Süd-West Kurze Straße 40 D-70794 Filderstadt Telefon: (07 11) 77 05 98-0 Telefax: (07 11) 77 05 98-79 MITSUBISHI ELECTRIC EUROPE B.V. Kunden-Technologie-Center Süd-Ost Am Söldnermoos 8 D-85399 Hallbergmoos Telefon: (08 11) 99 87 40 Telefax: (08 11) 99 87 410	VERTRETUNGEN MITTLERER OSTEN ilan & Gavish Ltd. ISRAEL Automation Service 24 Shenkar St., Kiryat Arie IL-49001 Petah-Tiqva Telefon: +972 (0) 3 / 922 18 24 Telefax: +972 (0) 3 / 924 07 61 E-Mail: iandg@internet-zahav.net Texel Electronics Ltd. ISRAEL Box 6272 IL-42160 Netanya Telefon: +972 (0) 9 / 863 08 91 Telefax: +972 (0) 9 / 885 24 30 E-Mail: texel_me@netvision.net.il	VERTRETUNG AFRIKA CBI Ltd. SÜDAFRIKA Private Bag 2016 ZA-1600 Isando Telefon: +27 (0) 11 / 928 2000 Telefax: +27 (0) 11 / 392 2354 E-Mail: cbi@cbi.co.za	