

# FX<sub>2N</sub>

## FX<sub>2N</sub>-4AD SPECIAL FUNCTION BLOCK USER'S GUIDE

JY992D65201A

This manual contains text, diagrams and explanations which will guide the reader in the correct installation and operation of the FX<sub>2N</sub>-4AD and should be read and understood before attempting to install or use the unit. Further information can be found in the FX SERIES PROGRAMMING MANUAL, FX<sub>2N</sub> SERIES HARDWARE MANUAL.

### 1 INTRODUCTION

- The FX<sub>2N</sub>-4AD analog special function block has four input channels. The input channels receive analog signals and convert them into a digital value. This is called an A/D conversion. The FX<sub>2N</sub>-4AD has maximum resolution of 12 bits.
- The selection of voltage or current based input/output is by user wiring. Analog ranges of -10 to 10V DC (resolution: 5mV), and/or 4 to 20mA, -20 to 20mA (resolution: 20μA) may be selected.
- Data transfer between the FX<sub>2N</sub>-4AD and the FX<sub>2N</sub> main unit is by buffer memory exchange. There are 32 buffer memories (each of 16 bits) in the FX<sub>2N</sub>-4AD.
- The FX<sub>2N</sub>-4AD occupies 8 points of I/O on the FX<sub>2N</sub> expansion bus. The 8 points can be allocated from either inputs or outputs. The FX<sub>2N</sub>-4AD draws 30mA from the 5V rail of the FX<sub>2N</sub> main unit or powered extension unit.

### 1.1 EXTERNAL DIMENSIONS

Weight : Approx. 0.3 kg (0.66 lbs)    Dimensions : mm (inches)

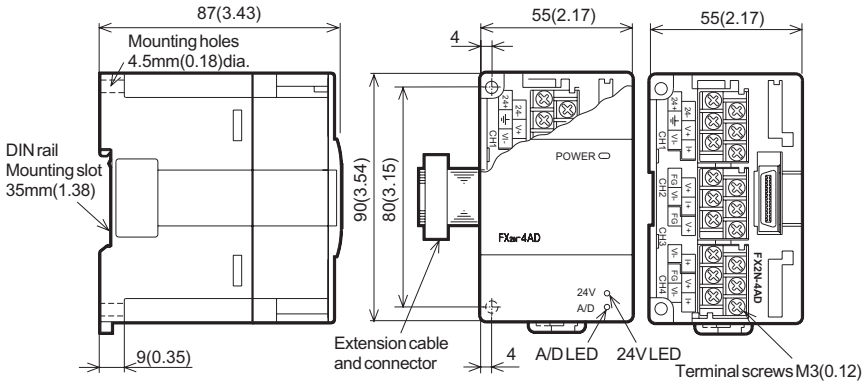

### 2 TERMINAL LAYOUTS

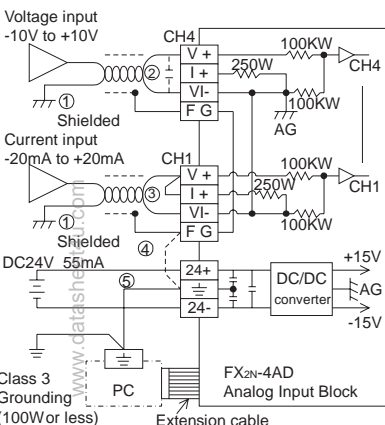

- The analog input is received through a twisted pair shielded cable. This cable should be wired separately from power lines or any other lines which may induce electrical noise.
- If a voltage ripple occurs during input, or there is electrically induced noise on the external wiring, connect a smoothing capacitor of 0.1 to 0.47μF, 25V.
- If you are using current input, connect the V+ and I+ terminals to each other.
- If there is excessive electrical noise, connect the FG frame ground terminal with the grounded terminal on the FX<sub>2N</sub>-4AD.
- Connect the ground terminal on the FX<sub>2N</sub>-4AD unit with the grounded terminal on the main unit. Use class 3 grounding on the main unit, if available.

**3.1 Environment specification**

Item	Specification
Environmental specifications (excluding following)	Same as those for the FX <sub>2N</sub> main unit
Dielectric withstand voltage	500VAC, 1min (between all terminals and ground)

**3.2 Power supply specification**

Item	Specification
Analog circuits	24V DC $\pm$ 10%, 55mA (external power supply from main unit)
Digital circuits	5V DC, 30mA (internal power supply from main unit)

**3.3 Performance specification****Analog Inputs**

Item	Voltage input	Current input
	Either voltage or current input can be selected with your choice of input terminal. Up to four input points can be used at one time.	
Analog input range	DC -10V to +10V (input resistance: 200k $\Omega$ ). Warning: this unit may be damaged by input voltage in excess of $\pm$ 15V.	DC -20mA to +20mA (input resistance: 250 $\Omega$ ). Warning: this unit may be damaged by input currents in excess of $\pm$ 32mA.
Digital output	12-bit conversion stored in 16-bit 2's complement form. Maximum value: +2047 Minimum value: -2048	
Resolution	5mV (10V default range 1/2000)	20 $\mu$ A (20mA default range 1/1000)
Over all accuracy	$\pm$ 1% (for the range of -10V to +10V)	$\pm$ 1% (for the range of -20mA to +20mA)
Conversion speed	15ms/channel (Normal speed), 6ms/channel (High speed)	

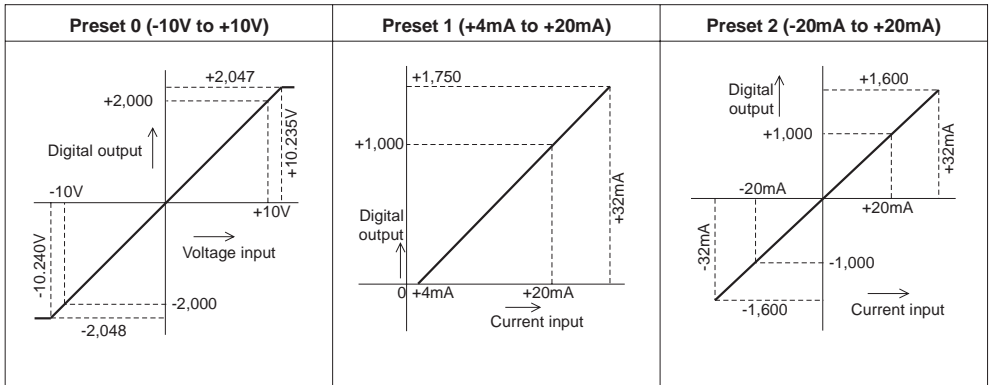
**Analog Inputs continued...**

**NOTE:** Preset ranges are selected by an appropriate setting in buffer memory of the analog block.  
Current/Voltage input selection must match the correct input terminal connections.

**Miscellaneous**

Item	Specification
Isolation	Photo-coupler isolation between analog and digital circuits. DC/DC converter isolation of power from FX <sub>2N</sub> MPU. No isolation between analog channels.
Number of occupied I/O points	8 points taken from the FX <sub>2N</sub> expansion bus (can be either inputs or outputs)

### 3.4 Allocation of buffer memories (BFM)

BFM	Contents	
*#0	Channel initialization	Default = H0000
*#1	Channel 1	Contains the number of samples (1 to 4096) to be used for an averaged result. The default setting is 8-normal speed. High speed operation can be selected with a value of 1.
*#2	Channel 2	
*#3	Channel 3	
*#4	Channel 4	
#5	Channel 1	These buffer memories contain the averaged input values for the number of samples entered for the channel in buffer memories #1 to #4 respectively.
#6	Channel 2	
#7	Channel 3	
#8	Channel 4	
#9	Channel 1	These buffer memories contain the present value currently being read by each input channel.
#10	Channel 2	
#11	Channel 3	
#12	Channel 4	
#13-#14	Reserved	
#15	Selection of A/D conversion speed see note 2	When set to 0, a normal speed is selected of 15ms/ch (default)
		When set to 1, a high speed is selected of 6ms/ch

In buffer memory locations (BFMs) marked with an "\*" data can be written from the PC using the TO command.

For buffer memories (BFMs) without "\*" mark, data can be read to the PC using the FROM command.

Before reading from the analog special function block, ensure these settings have been sent to the analog special function block. Otherwise, the previous values held in the analog block will be used.

BFM		b7	b6	b5	b4	b3	b2	b1	b0
#16-#19	Reserved								
*#20	Reset to Defaults and Preset.	Default = 0							
*#21	Offset, Gain Adjust Prohibit.	Default = (0, 1) Permit							
*#22	Offset, Gain Adjust	G4	O4	G3	O3	G2	O2	G1	O1
*#23	Offset Value	Default = 0							
*#24	Gain Value	Default = 5,000							
#25-#28	Reserved								
#29	Error status								
#30	Identification code K2010								
#31	Cannot be used								

The buffer memory also gives a facility to adjust offset and gain by software.

Offset (intercept): The analog input value when the digital output becomes 0.

Gain (slope): The analog input value when the digital output becomes +1000.

#### (1) Channel Selection

Channel initialization is made by a 4 character HEX number H0000 in buffer memory BFM #0. The least significant character controls channel 1 and the 4 character controls channel 4.

Setting of each character is as follows:

O = 0: Preset range (-10V to +10V)                      O = 2: Preset range (-20mA to +20mA)  
 O = 1: Preset range (+4mA to +20mA)                O = 3: Channel OFF

Example: H3310

CH1: Preset range (-10V to +10V)  
 CH2: Preset range (+4mA to +20mA)  
 CH3, CH4: Channel OFF

#### (2) Analog to Digital Conversion Speed Change

By writing 0 or 1 into BFM #15 of the FX2N-4AD, the speed at which A/D conversion is performed can be changed.

However the following points should be noted:

To maintain a high speed conversion rate, use the FROM/TO commands as seldom as possible.

*NOTES: When a conversion speed change is made, BFM #1-#4 are set to their default values immediately after the change. This is regardless of the values they held originally. Bear this in mind if a speed change will be made as part of the normal program execution.*

#### (3) Adjusting Gain and Offset values

- When buffer memory BFM #20 is activated by setting it to K1, all settings within the analog special function block are reset to their default settings. This is a very quick method to erase any undesired gain and offset adjustments.
- If (b1, b0) of BFM #21 is set to (1,0), gain and offset adjustments are prohibited to prevent inadvertent changes by the operator. In order to adjust the gain and offset values, bits (b1, b0) must be set to (0,1). The default is (0,1).
- Gain and offset values of BFM #23 and #24 are sent to non-volatile memory gain and offset registers of the specified input channels. Input channels to be adjusted are specified by the appropriate G-O (gain-offset) bits of BFM #22  
 Example: If bits G1 and O1 are set to 1, input channel 1 will be adjusted when BFM #22 is written to by a TO instruction.
- Channels can be adjusted individually or together with the same gain and offset values.
- Gain and offset values in BFM #23 #24 are in units of mV or  $\mu$ A. Due to the resolution of the unit the actual response will be in steps of 5mV or 20 $\mu$ A.

**(4) Status Information BFM #29**

Bit devices of BFM #29	ON	OFF
b0 : Error	When any of b1 to b4 is ON. If any of b2 to b4 is ON, A/D conversion of all the channels is stopped	No error
b1 : Offset / gain error	Offset/Gain data in EEPROM is corrupted or adjustment error.	Offset/Gain data normal
b2 : Power source abnormality	24V DC power supply failure	Power supply normal
b3 : Hardware error	A/D converter or other hardware failure	Hardware Normal
b10 : Digital range error	Digital output value is less than -2048 or more than +2047	Digital output value is normal.
b11: Averaging error	Number of averaging samples is 4097 or more or 0 or less (default of 8 will be used)	Averaging is normal. (between 1 and 4096)
b12: Offset / gain adjust prohibit	Prohibit-(b1, b0) of BFM #21 is set to (1, 0)	Permit-(b1, b0) of BFM #21 is set to (0,1)

NOTE: b4 to b7, b9 and b13 to b15 are undefined.

www.DataSheet4U.com

**(5) Identification Code BFM #30**

The identification (or ID) code number for a Special Function Block is read using the FROM command.

This number for the FX<sub>2N</sub>-4AD unit is K2010.

The user's program in the PC can use this facility in the program to identify the special function block before commencing data transfer from and to the special function block.

**CAUTION**

- Values of BFM #0, #23 and #24 are copied to EEPROM memory of the FX<sub>2N</sub>-4AD. BFM #21 and BFM #22 are only copied when data is written to the gain/offset command buffer BFM #22. Also, BFM #20 causes writing to the EEPROM memory. The EEPROM has a life of about 10,000 cycles (changes), so do not use programs which frequently change these BFMs.
- Because of the time needed to write to the EEPROM memory, a delay of 300 ms is required between instructions that cause a write to the EEPROM. Therefore, a delay timer should be used before writing to the EEPROM a second time.

4

**DEFINING GAIN AND OFFSET**

**Gain**

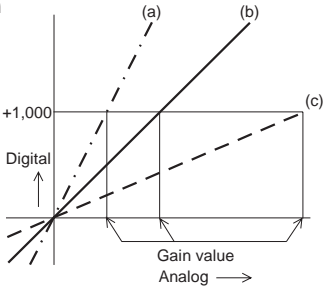

**Offset**

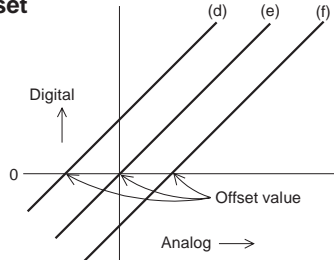

Gain determines the angle or slope of the calibration line, identified at a digital value of 1000.

Offset is the 'Position' of the calibrated line, identified at a digital value of 0.

- (a) Small gain      Large steps in digital readings
- (b) Zero gain      default : 5V or 20mA
- (c) Large gain      Small steps in digital readings

- (d) Negative offset
- (e) Zero offset      default : 0V or 4mA
- (f) Positive offset

Offset and gain can be set independently or together. Reasonable offset ranges are -5 to +5V or -20mA to 20mA, and gain values 1V to 15V or 4mA to 32mA. Gain and offset can be adjusted by software in the FX<sub>2N</sub> main unit (see program example 2)

- Bit device's b1, b2 of the gain/offset BFM #21 should be set to 0, 1 to allow adjustment.
- Once adjustment is complete these bit devices should be set to 1, 0 to prohibit any further changes.
- Channel initialization (BFM #0) should be set to the nearest range, i. e. voltage/current etc.

www.datasheet4u.com

### 5.1 Basic Program

In the following example channels CH1 and CH2 are used as voltage inputs. The FX<sub>2N</sub>-4AD block is connected at the position of special function block No.0. Averaging is set at 4 and data registers D0 and D1 of the PC receive the averaged digital data.

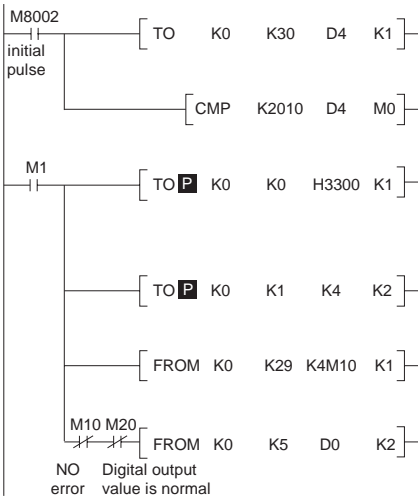

The ID code for the special function block at position "0" is read from BFM #30 of that block and stored at D4 in the main unit. This is compared to check the block is a FX<sub>2N</sub>-4AD, if OK, M1 is turned ON. These two program steps are not strictly needed to perform an analog read. They are however a useful check and are recommended as good practice.

The analog input channels (CH1, CH2) are setup by writing H3300 to BFM #0 of the FX<sub>2N</sub>-4AD.

The number of averaged samples for CH1 and CH2 is set to 4 by writing 4 to BFM #1 and #2 respectively.

The operational status of the FX<sub>2N</sub>-4AD is read from BFM #29 and output as bit devices at the FX<sub>2N</sub> main unit.

If there are no errors in the operation of the FX<sub>2N</sub>-4AD, then the averaged data BFM's are read. In the case of this example BFM #5 and #6 are read into the FX<sub>2N</sub> main unit and stored at D0 and D1. These devices contain the averaged data for CH1 and CH2 respectively.

### 5.2 Using gain and offset in a program

The gain and offset of the FX<sub>2N</sub>-4AD can be adjusted using push-button switches on the input terminal of the PC. It can also be adjusted using software settings sent from the PC.

Only the gain and offset values in the memory of the FX<sub>2N</sub>-4AD need be adjusted. A voltmeter or an ammeter for the analog input is not needed. A program for the PC will be needed however.

The following is an example of changing the offset value on input channel CH1 to 0V and the gain value to 2.5V.

The FX<sub>2N</sub>-4AD block is in the position of block No.0 (i.e. closest to the FX<sub>2N</sub> main unit).

Example: Adjusting gain/offset via software settings

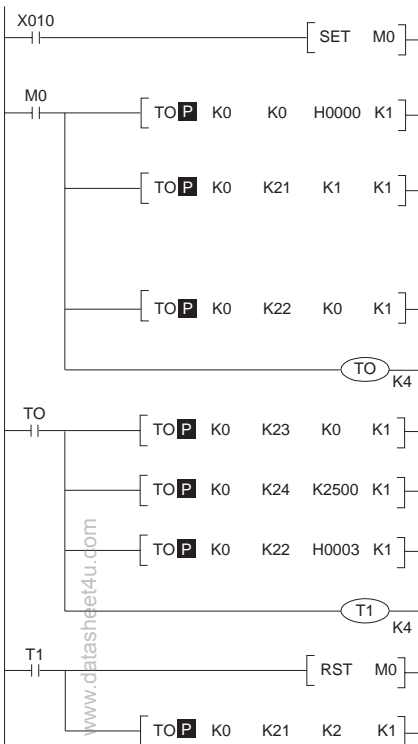

Adjustment start.

(H0000) → BFM #0 (initialize input channels)  
Enter the instructions on the left and RUN the PC.

(K1) → BFM #21  
BFM #21 (gain/offset adjust prohibit) must be set to permit with  
(b1, b0) = (0,1).

(K0) → BFM #22 (offset/gain adjust)  
Reset adjust bits.

(K0) → BFM #23 (offset)

(K2500) → BFM #24 (gain)

(H0003) → BFM #22 (offset/gain adjust)  
3 = 0011 i.e. O1 = 1, G1 = 1.  
Therefore channel 1 is adjusted.

Adjustment end.

(K2) → BFM #21  
BFM #21 gain/offset adjust prohibit.

**6.1 Preliminary checks**

- I. Check whether the input wiring and/or extension cables are properly connected on FX<sub>2N</sub>-4AD analog special function block
- II. Check that the FX<sub>2N</sub> system configuration rules have not been broken, i.e. the number of special function blocks does not exceed 8 and the total system I/O is equal or less than 256 I/O.
- III. Ensure that the correct operating range has been selected for the application.
- IV. Check that there is no power overload on either the 5V or 24V power sources, remember the loading on a FX<sub>2N</sub> main unit or a powered extension unit varies according to the number of extension blocks or special function blocks connected.
- V. Put the FX<sub>2N</sub> main unit into RUN.

**6.2 Error checking**

If the FX<sub>2N</sub>-4AD special function block does not seem to operate normally, check the following items.

- Check the status of the POWER LED.
  - Lit : The extension cable is properly connected.
  - Otherwise : Check the connection of the extension cable.
- Check the external wiring.
- Check the status for the "24V" LED (top right corner of the FX<sub>2N</sub>-4AD).
  - Lit : FX<sub>2N</sub>-4AD is OK, 24V DC power source is OK.
  - Otherwise : Possible 24VDC power failure, if OK possible FX<sub>2N</sub>-4AD failure.
- Check the status for the "A/D" LED (top right corner of the FX<sub>2N</sub>-4AD).
  - Lit : A/D conversion is proceeding normally.
  - Otherwise : Check buffer memory #29 (error status). If any bits (b2 and b3) are ON, then this is why the A/D LED is OFF.

**Guidelines for the safety of the user and protection of the FX<sub>2N</sub>-4AD special function block**

- This manual has been written to be used by trained and competent personnel. This is defined by the European directives for machinery, low voltage and EMC.
- If in doubt at any stage during the installation of the FX<sub>2N</sub>-4AD always consult a professional electrical engineer who is qualified and trained to the local and national standards. If in doubt about the operation or use of the FX<sub>2N</sub>-4AD please consult the nearest Mitsubishi Electric distributor.
- Under no circumstances will Mitsubishi Electric be liable or responsible for any consequential damage that may arise as a result of the installation or use of this equipment.
- All examples and diagrams shown in this manual are intended only as an aid to understanding the text, not to guarantee operation. Mitsubishi Electric will accept no responsibility for actual use of the product based on these illustrative examples.

Manual number : JY992D65201

Manual revision : A

Date : JUNE 1997



**MITSUBISHI ELECTRIC CORPORATION**

HEAD OFFICE: MITSUBISHI DENKI BLDG MARUNOUCHI TOKYO 100 TELEX: J24532 CABLE MELCO TOKYO  
HIMEJI WORKS: 840, CHIYODA CHO, HIMEJI, JAPAN



# FX<sub>2N</sub>

## FX<sub>2N</sub>-4AD SPECIAL FUNCTION BLOCK

### USER'S GUIDE

JY992D65201A

This manual contains text, diagrams and explanations which will guide the reader in the correct installation and operation of the FX<sub>2N</sub>-4AD and should be read and understood before attempting to install or use the unit. Further information can be found in the FX SERIES PROGRAMMING MANUAL, FX<sub>2N</sub> SERIES HARDWARE MANUAL.

## 1 INTRODUCTION

- The FX<sub>2N</sub>-4AD analog special function block has four input channels. The input channels receive analog signals and convert them into a digital value. This is called an A/D conversion. The FX<sub>2N</sub>-4AD has maximum resolution of 12 bits.
- The selection of voltage or current based input/output is by user wiring. Analog ranges of -10 to 10V DC (resolution: 5mV), and/or 4 to 20mA, -20 to 20mA (resolution: 20µA) may be selected.
- Data transfer between the FX<sub>2N</sub>-4AD and the FX<sub>2N</sub> main unit is by buffer memory exchange. There are 32 buffer memories (each of 16 bits) in the FX<sub>2N</sub>-4AD.
- The FX<sub>2N</sub>-4AD occupies 8 points of I/O on the FX<sub>2N</sub> expansion bus. The 8 points can be allocated from either inputs or outputs. The FX<sub>2N</sub>-4AD draws 30mA from the 5V rail of the FX<sub>2N</sub> main unit or powered extension unit.

### 1.1 EXTERNAL DIMENSIONS

Weight : Approx. 0.3 kg (0.66 lbs)    Dimensions : mm (inches)

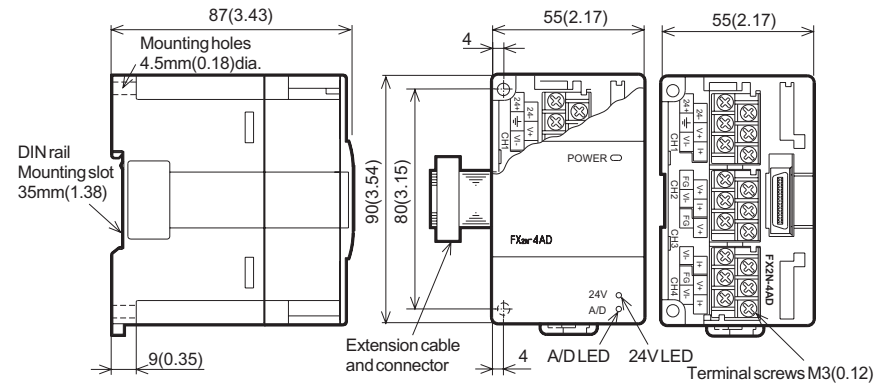

## 2 TERMINAL LAYOUTS

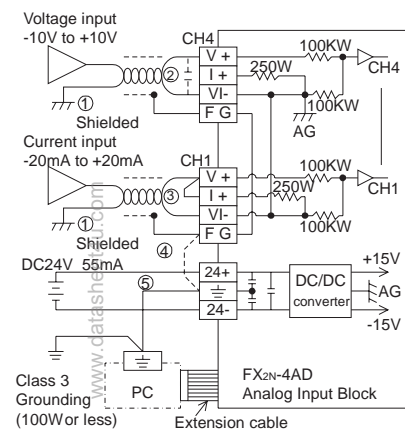

- The analog input is received through a twisted pair shielded cable. This cable should be wired separately from power lines or any other lines which may induce electrical noise.
- If a voltage ripple occurs during input, or there is electrically induced noise on the external wiring, connect a smoothing capacitor of 0.1 to 0.47µF, 25V.
- If you are using current input, connect the V+ and I+ terminals to each other.
- If there is excessive electrical noise, connect the FG frame ground terminal with the grounded terminal on the FX<sub>2N</sub>-4AD.
- Connect the ground terminal on the FX<sub>2N</sub>-4AD unit with the grounded terminal on the main unit. Use class 3 grounding on the main unit, if available.

## 3 INSTALLATION NOTES AND USAGE

### 3.1 Environment specification

Item	Specification
Environmental specifications (excluding following)	Same as those for the FX <sub>2N</sub> main unit
Dielectric withstand voltage	500VAC, 1min (between all terminals and ground)

### 3.2 Power supply specification

Item	Specification
Analog circuits	24V DC ± 10%, 55mA (external power supply from main unit)
Digital circuits	5V DC, 30mA (internal power supply from main unit)

### 3.3 Performance specification

#### Analog Inputs

Item	Voltage input	Current input
	Either voltage or current input can be selected with your choice of input terminal. Up to four input points can be used at one time.	
Analog input range	DC -10V to +10V (input resistance: 200kΩ). Warning: this unit may be damaged by input voltage in excess of ±15V.	DC -20mA to +20mA (input resistance: 250Ω). Warning: this unit may be damaged by input currents in excess of ±32mA.
Digital output	12-bit conversion stored in 16-bit 2's complement form. Maximum value: +2047 Minimum value: -2048	
Resolution	5mV (10V default range 1/2000)	20µA (20mA default range 1/1000)
Over all accuracy	±1% (for the range of -10V to +10V)	±1% (for the range of -20mA to +20mA)
Conversion speed	15ms/channel (Normal speed), 6ms/channel (High speed)	

#### Analog Inputs continued...

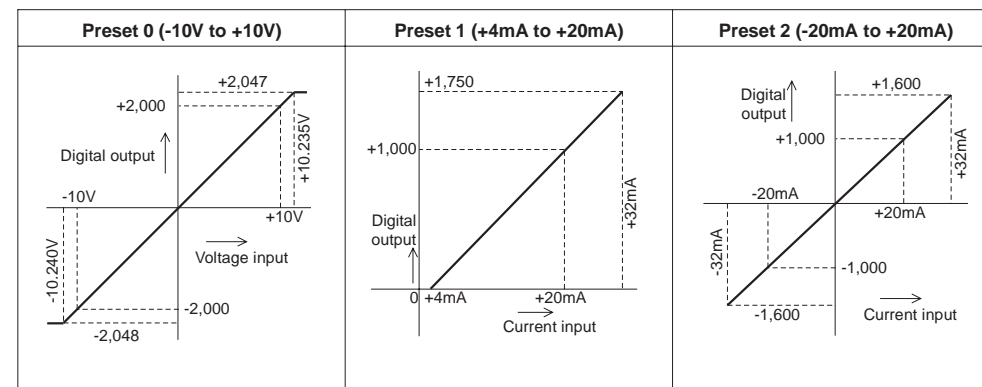

NOTE: Preset ranges are selected by an appropriate setting in buffer memory of the analog block. Current/Voltage input selection must match the correct input terminal connections.

#### Miscellaneous

Item	Specification
Isolation	Photo-coupler isolation between analog and digital circuits. DC/DC converter isolation of power from FX <sub>2N</sub> MPU. No isolation between analog channels.
Number of occupied I/O points	8 points taken from the FX <sub>2N</sub> expansion bus (can be either inputs or outputs)

### 3.4 Allocation of buffer memories (BFM)

BFM	Contents	
*#0	Channel initialization	Default = H0000
*#1	Channel 1	Contains the number of samples (1 to 4096) to be used for an averaged result. The default setting is 8-normal speed. High speed operation can be selected with a value of 1.
*#2	Channel 2	
*#3	Channel 3	
*#4	Channel 4	
#5	Channel 1	These buffer memories contain the averaged input values for the number of samples entered for the channel in buffer memories #1 to #4 respectively.
#6	Channel 2	
#7	Channel 3	
#8	Channel 4	
#9	Channel 1	These buffer memories contain the present value currently being read by each input channel.
#10	Channel 2	
#11	Channel 3	
#12	Channel 4	
#13-#14	Reserved	
#15	Selection of A/D conversion speed see note 2	When set to 0, a normal speed is selected of 15ms/ch (default) When set to 1, a high speed is selected of 6ms/ch

BFM	b7	b6	b5	b4	b3	b2	b1	b0
#16-#19	Reserved							
*#20	Reset to Defaults and Preset. Default = 0							
*#21	Offset, Gain Adjust Prohibit. Default = (0, 1) Permit							
*#22	G4	O4	G3	O3	G2	O2	G1	O1
*#23	Offset Value Default = 0							
*#24	Gain Value Default = 5,000							
#25-#28	Reserved							
#29	Error status							
#30	Identification code K2010							
#31	Cannot be used							

#### (1) Channel Selection

Channel initialization is made by a 4 character HEX number H0000 in buffer memory BFM #0. The least significant character controls channel 1 and the 4 character controls channel 4.

Setting of each character is as follows:

- O = 0: Preset range (-10V to +10V)
- O = 1: Preset range (+4mA to +20mA)
- O = 2: Preset range (-20mA to +20mA)
- O = 3: Channel OFF

Example: H3310

- CH1: Preset range (-10V to +10V)
- CH2: Preset range (+4mA to +20mA)
- CH3, CH4: Channel OFF

#### (2) Analog to Digital Conversion Speed Change

By writing 0 or 1 into BFM #15 of the FX<sub>2N</sub>-4AD, the speed at which A/D conversion is performed can be changed. However the following points should be noted: To maintain a high speed conversion rate, use the FROM/TO commands as seldom as possible.

NOTES: When a conversion speed change is made, BFM #1-#4 are set to their default values immediately after the change. This is regardless of the values they held originally. Bear this in mind if a speed change will be made as part of the normal program execution.

#### (3) Adjusting Gain and Offset values

- When buffer memory BFM #20 is activated by setting it to K1, all settings within the analog special function block are reset to their default settings. This is a very quick method to erase any undesired gain and offset adjustments.
- If (b1, b0) of BFM #21 is set to (1,0), gain and offset adjustments are prohibited to prevent inadvertent changes by the operator. In order to adjust the gain and offset values, bits (b1, b0) must be set to (0,1). The default is (0,1).
- Gain and offset values of BFM #23 and #24 are sent to non-volatile memory gain and offset registers of the specified input channels. Input channels to be adjusted are specified by the appropriate G-O (gain-offset) bits of BFM #22  
Example: If bits G1 and O1 are set to 1, input channel 1 will be adjusted when BFM #22 is written to by a TO instruction.
- Channels can be adjusted individually or together with the same gain and offset values.
- Gain and offset values in BFM #23 #24 are in units of mV or µA. Due to the resolution of the unit the actual response will be in steps of 5mV or 20µA.

In buffer memory locations (BFMs) marked with an "\*" data can be written from the PC using the TO command.

For buffer memories (BFMs) without "\*" mark, data can be read to the PC using the FROM command.

Before reading from the analog special function block, ensure these settings have been sent to the analog special function block. Otherwise, the previous values held in the analog block will be used.

The buffer memory also gives a facility to adjust offset and gain by software.

Offset (intercept): The analog input value when the digital output becomes 0.

Gain (slope): The analog input value when the digital output becomes +1000.

**(4) Status Information BFM #29**

Bit devices of BFM #29	ON	OFF
b0 : Error	When any of b1 to b4 is ON. If any of b2 to b4 is ON, A/D conversion of all the channels is stopped	No error
b1 : Offset / gain error	Offset/Gain data in EEPROM is corrupted or adjustment error.	Offset/Gain data normal
b2 : Power source abnormality	24V DC power supply failure	Power supply normal
b3 : Hardware error	A/D converter or other hardware failure	Hardware Normal
b10 : Digital range error	Digital output value is less than -2048 or more than +2047	Digital output value is normal.
b11: Averaging error	Number of averaging samples is 4097 or more or 0 or less (default of 8 will be used)	Averaging is normal. (between 1 and 4096)
b12: Offset / gain adjust prohibit	Prohibit-(b1, b0) of BFM #21 is set to (1, 0)	Permit-(b1, b0) of BFM #21 is set to (0,1)

NOTE: b4 to b7, b9 and b13 to b15 are undefined.

**(5) Identification Code BFM #30**

The identification (or ID) code number for a Special Function Block is read using the FROM command.

This number for the FX2N-4AD unit is K2010.

The user's program in the PC can use this facility in the program to identify the special function block before commencing data transfer from and to the special function block.

**CAUTION**

- Values of BFM #0, #23 and #24 are copied to EEPROM memory of the FX2N-4AD. BFM #21 and BFM #22 are only copied when data is written to the gain/offset command buffer BFM #22. Also, BFM #20 causes writing to the EEPROM memory. The EEPROM has a life of about 10,000 cycles (changes), so do not use programs which frequently change these BFMs.
- Because of the time needed to write to the EEPROM memory, a delay of 300 ms is required between instructions that cause a write to the EEPROM. Therefore, a delay timer should be used before writing to the EEPROM a second time.

**5 EXAMPLE PROGRAM**

**5.1 Basic Program**

In the following example channels CH1 and CH2 are used as voltage inputs. The FX2N-4AD block is connected at the position of special function block No.0. Averaging is set at 4 and data registers D0 and D1 of the PC receive the averaged digital data.

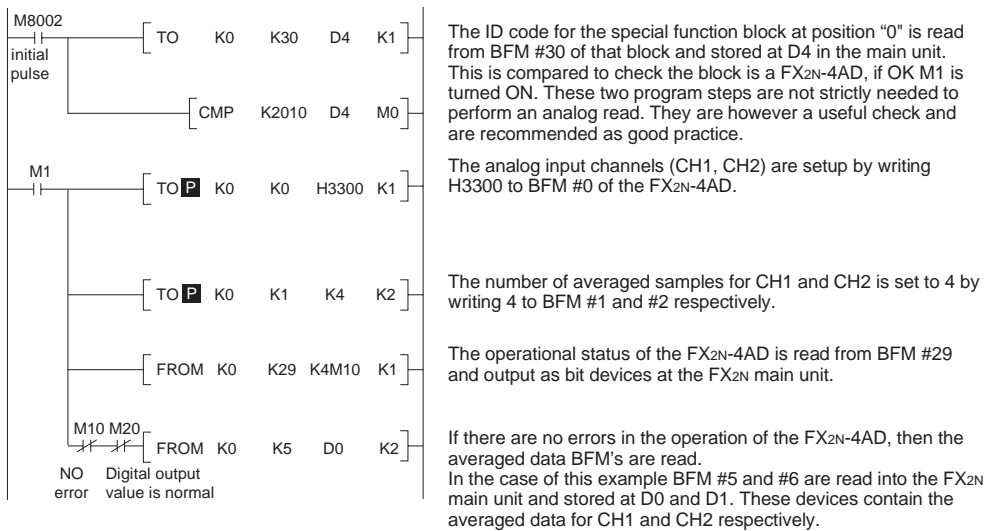

**6 DIAGNOSTICS**

**6.1 Preliminary checks**

- Check whether the input wiring and/or extension cables are properly connected on FX2N-4AD analog special function block
- Check that the FX2N system configuration rules have not been broken, i.e. the number of special function blocks does not exceed 8 and the total system I/O is equal or less than 256 I/O.
- Ensure that the correct operating range has been selected for the application.
- Check that there is no power overload on either the 5V or 24V power sources, remember the loading on a FX2N main unit or a powered extension unit varies according to the number of extension blocks or special function blocks connected.
- Put the FX2N main unit into RUN.

**6.2 Error checking**

If the FX2N-4AD special function block does not seem to operate normally, check the following items.

- Check the status of the POWER LED.
  - Lit : The extension cable is properly connected.
  - Otherwise : Check the connection of the extension cable.
- Check the external wiring.
- Check the status for the "24V" LED (top right corner of the FX2N-4AD).
  - Lit : FX2N-4AD is OK, 24V DC power source is OK.
  - Otherwise : Possible 24VDC power failure, if OK possible FX2N-4AD failure.
- Check the status for the "A/D" LED (top right corner of the FX2N-4AD).
  - Lit : A/D conversion is proceeding normally.
  - Otherwise : Check buffer memory #29 (error status). If any bits (b2 and b3) are ON, then this is why the A/D LED is OFF.

**4 DEFINING GAIN AND OFFSET**

**Gain**

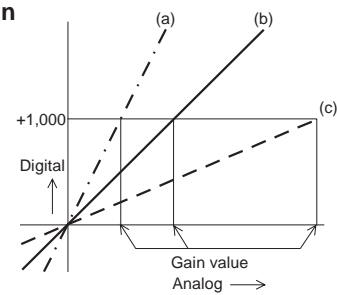

**Offset**

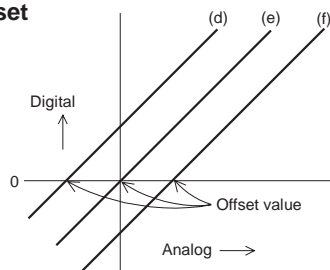

Gain determines the angle or slope of the calibration line, identified at a digital value of 1000.

Offset is the 'Position' of the calibrated line, identified at a digital value of 0.

- |                |                                 |                                     |
|----------------|---------------------------------|-------------------------------------|
| (a) Small gain | Large steps in digital readings | (d) Negative offset                 |
| (b) Zero gain  | default : 5V or 20mA            | (e) Zero offset default : 0V or 4mA |
| (c) Large gain | Small steps in digital readings | (f) Positive offset                 |

Offset and gain can be set independently or together. Reasonable offset ranges are -5 to +5V or -20mA to 20mA, and gain values 1V to 15V or 4mA to 32mA. Gain and offset can be adjusted by software in the FX2N main unit (see program example 2)

- Bit device's b1, b2 of the gain/offset BFM #21 should be set to 0, 1 to allow adjustment.
- Once adjustment is complete these bit devices should be set to 1, 0 to prohibit any further changes.
- Channel initialization (BFM #0) should be set to the nearest range, i. e. voltage/current etc.

**5.2 Using gain and offset in a program**

The gain and offset of the FX2N-4AD can be adjusted using push-button switches on the input terminal of the PC. It can also be adjusted using software settings sent from the PC.

Only the gain and offset values in the memory of the FX2N-4AD need be adjusted. A voltmeter or an ammeter for the analog input is not needed. A program for the PC will be needed however.

The following is an example of changing the offset value on input channel CH1 to 0V and the gain value to 2.5V.

The FX2N-4AD block is in the position of block No.0 (i.e. closest to the FX2N main unit).

Example: Adjusting gain/offset via software settings

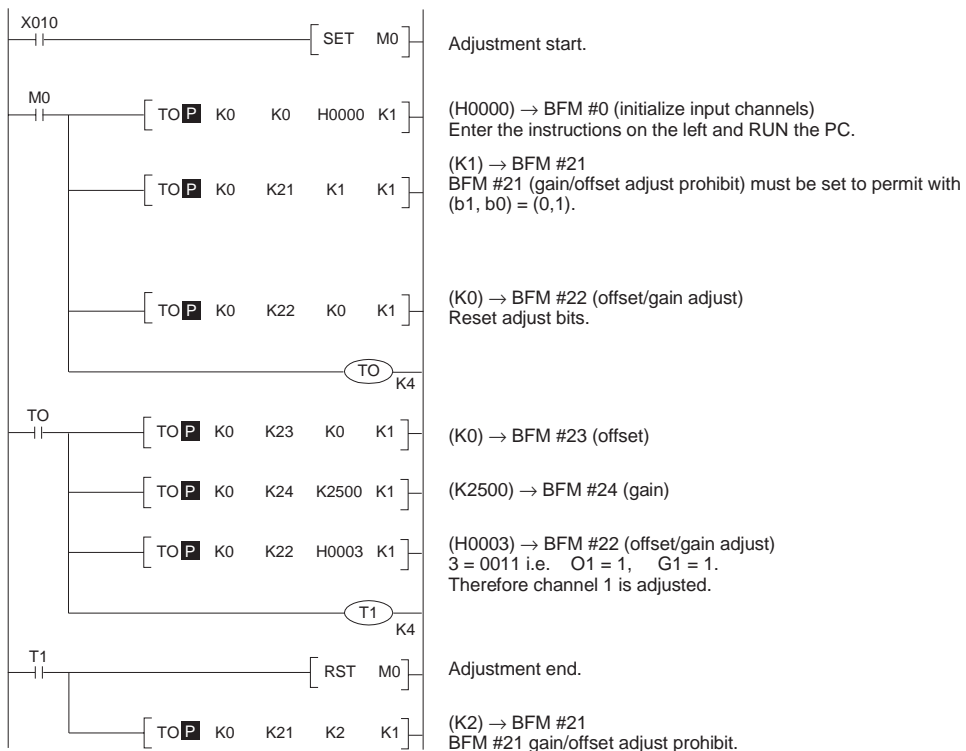

**Guidelines for the safety of the user and protection of the FX2N-4AD special function block**

- This manual has been written to be used by trained and competent personnel. This is defined by the European directives for machinery, low voltage and EMC.
- If in doubt at any stage during the installation of the FX2N-24AD always consult a professional electrical engineer who is qualified and trained to the local and national standards. If in doubt about the operation or use of the FX2N-4AD please consult the nearest Mitsubishi Electric distributor.
- Under no circumstances will Mitsubishi Electric be liable or responsible for any consequential damage that may arise as a result of the installation or use of this equipment.
- All examples and diagrams shown in this manual are intended only as an aid to understanding the text, not to guarantee operation. Mitsubishi Electric will accept no responsibility for actual use of the product based on these illustrative examples.

Manual number : JY992D65201  
 Manual revision : A  
 Date : JUNE 1997

