

# PRODUCT SPECIFICATION

## Model No.: FYL-48D2PGC1A

| Descriptions:                              |
|--|
| ■ Dice material: InGaN.                    |
| ■ Emitting Color: Super bright Pure Green. |
| ■ Device Outline: Φ4.8mm straw hat type.   |
| ■ Lens Type: Water clear.                  |



| CUSTOMER APPROVED SIGNATURES | APPROVED BY | CHECKED BY | PREPARED BY |
|------------------------------|-------------|------------|-------------|
|                              |             |            |             |

**NINGBO FORYARD OPTOELECTRONICS CO.,LTD.**

**Add:**NO.115 Qixin Road Ningbo Zhejiang China

**Zip:**315051

**Tel:** 0086-574-87933652 87927870 87922206

**Fax:** 0086-574-87927917

**E-mail:** Sales@foryard.com (General)

[Http://www.foryard.com](http://www.foryard.com)

## ■ Features

1. Low power consumption.
2. High efficiency.
3. General purpose leads.
4. High intensity.
5. RoHs compliant.

## ■ Package configuration

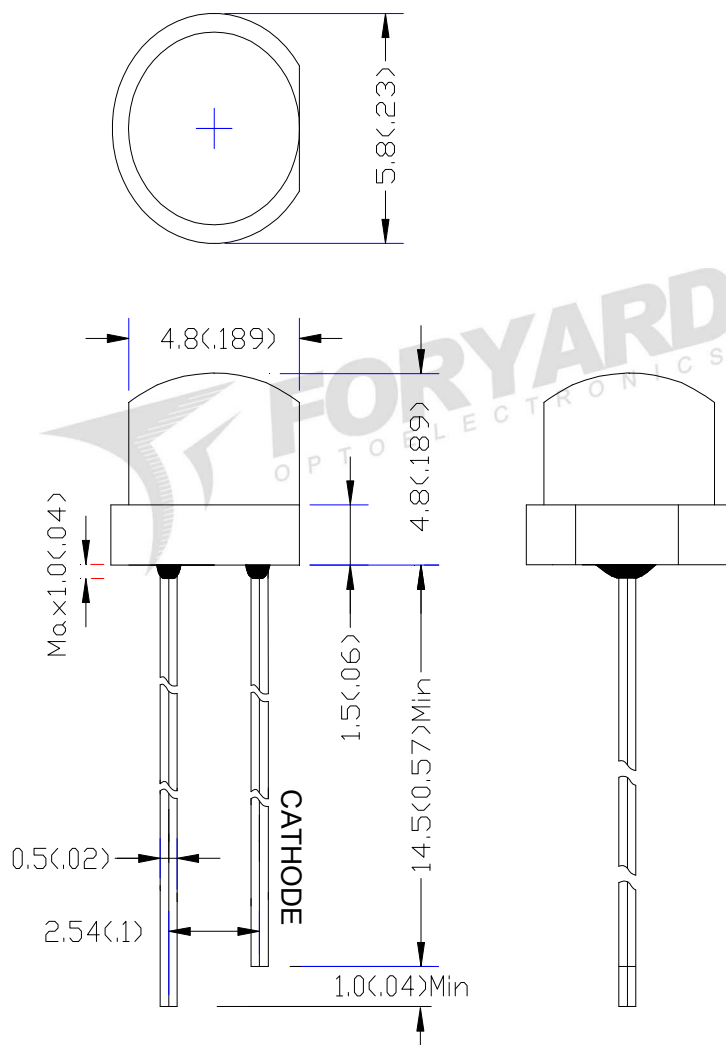

### Notes:

1. All dimensions are millimeters (inches)
2. Tolerance is  $\pm 0.25\text{mm} (0.010\text{'})$  unless otherwise noted.
3. The specifications, characteristics and technical data described in the datasheet are subject to change without prior notice.

■ Absolute maximum ratings(Ta=25 ° c)

| Parameter   | MAX.                | Unit  |
|---|---------------------|-------|
| Power Dissipation   | 90                  | mW    |
| Peak Forward Current (1/10 Duty Cycle, 0.1ms Pulse Width) | 100                 | mA    |
| Continuous Forward Current                                | 25                  | mA    |
| Derating Linear From 50°C                                 | 0.4                 | mA/°C |
| Reverse Voltage   | 5                   | V     |
| Operating Temperature Range                               | -40°C to +85°C      |       |
| Storage Temperature Range                                 | -40°C to +100°C     |       |
| Lead Soldering Temperature[4mm(.157") From Body]          | 260°C for 5 Seconds |       |

■ Electrical and optical characteristics(Ta=25 ° c)

| Parameter                | Symbol          | Min. | Typ. | Max. | Unit    | Test Condition |
|--------------------------|-----------------|------|------|------|---------|----------------|
| Luminous Intensity       | $I_v$           | -    | 2000 | -    | mcd     | $I_F=20mA$     |
| Viewing Angle            | $2\theta_{1/2}$ | -    | 80   | -    | Deg     |                |
| Peak Emission Wavelength | $\lambda_p$     | -    | 520  | -    | nm      |                |
| Dominant Wavelength      | $\lambda_d$     | 517  | 522  | 527  | nm      |                |
| Spectral Line Half-Width | $\Delta\lambda$ | -    | 30   | -    | nm      |                |
| Forward Voltage          | $V_F$           | 2.8  | 3.2  | 3.6  | V       |                |
| Reverse Current          | $I_R$           |      |      | 10   | $\mu A$ | $V_R=5V$       |

■ **Typical Electrical Characteristics Curves**  
**(25 °c Ambient Temperature Unless Otherwise Noted)**

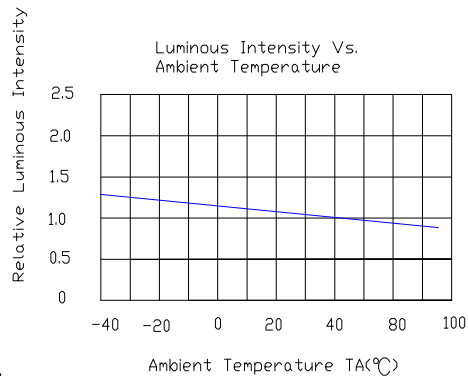
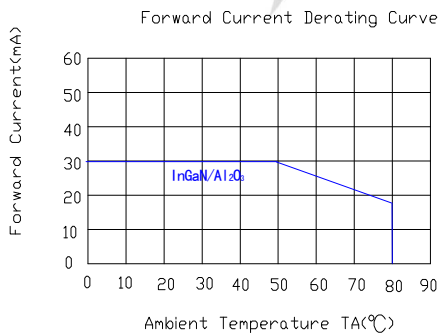
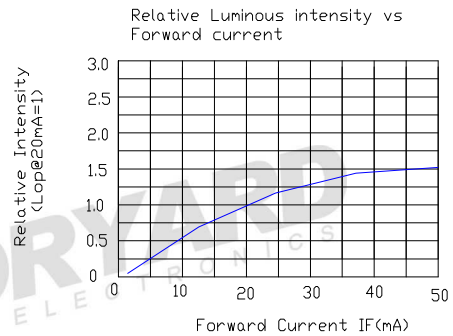
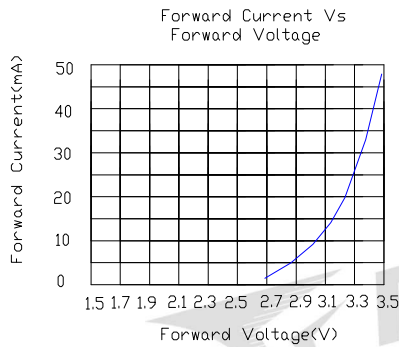
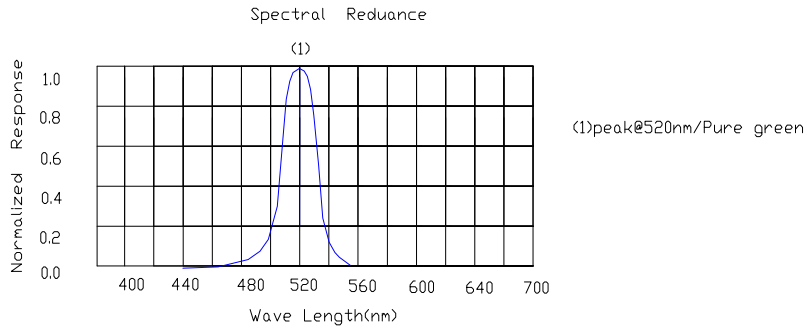

**Radiation pattern.**

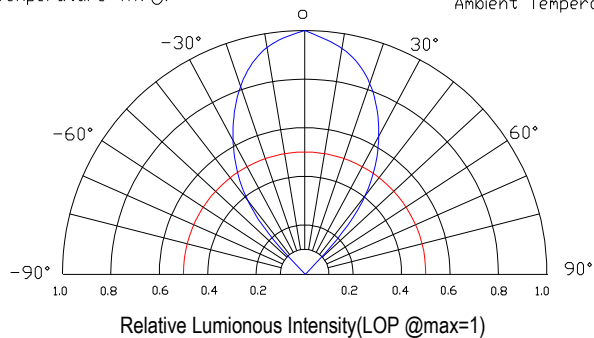

|            |               |
|------------|---------------|
| Model. No. | FYL-48D2PGC1A |
| Rev.       | A             |

■ LAMP PACKING.

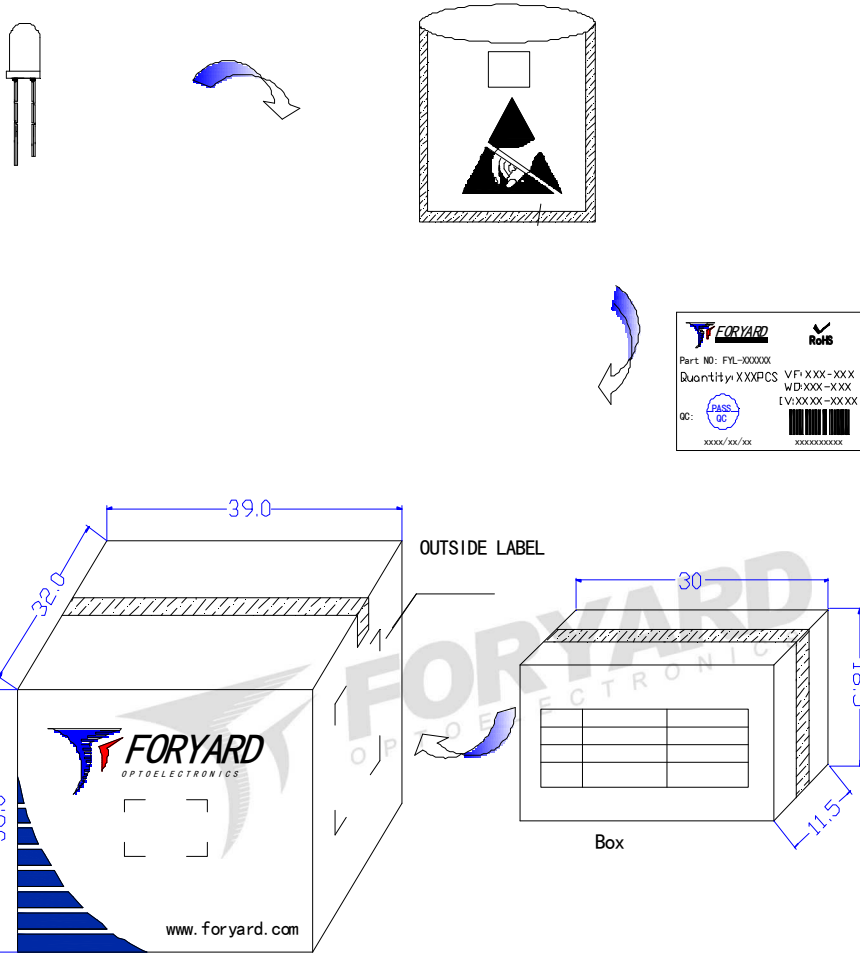

6Boxes/Carton



**LED**

PN: FYL-xxxxxxxx-xx

Qty: XXXX PCS



Date: xxxx/xx/xx

QC: PASS  
QC

GW: xx KG    NW: xx KG



XXXXXXXXXX

OUTSIDE LABEL