

Technische Information / Technical Information

IGBT-Module
IGBT-Modules

FZ 800 R12 KS4

eupec



Vorläufige Daten
Preliminary data

Höchstzulässige Werte / Maximum rated values

Elektrische Eigenschaften / Electrical properties

Kollektor-Emitter-Sperrspannung collector-emitter voltage		V_{CES}	1200	V
Kollektor-Dauergleichstrom DC-collector current	$T_C = 80^\circ\text{C}$	$I_{C,nom.}$	800	A
	$T_C = 25^\circ\text{C}$	I_C	1200	A
Periodischer Kollektor Spitzenstrom repetitive peak collector current	$t_p = 1\text{ ms}, T_C = 80^\circ\text{C}$	I_{CRM}	1600	A
Gesamt-Verlustleistung total power dissipation	$T_C = 25^\circ\text{C}, \text{ Transistor}$	P_{tot}	6,9	kW
Gate-Emitter-Spitzenspannung gate-emitter peak voltage		V_{GES}	+/- 20V	V
Dauergleichstrom DC forward current		I_F	800	A
Periodischer Spitzenstrom repetitive peak forw. current	$t_p = 1\text{ ms}$	I_{FRM}	1600	A
Grenzlastintegral der Diode I^2t - value, Diode	$V_R = 0V, t_p = 10\text{ms}, T_{vj} = 125^\circ\text{C}$	I^2t	185.000	A^2s
Isolations-Prüfspannung insulation test voltage	RMS, $f = 50\text{ Hz}, t = 1\text{ min.}$	V_{ISOL}	2.500	V

Charakteristische Werte / Characteristic values

Transistor / Transistor

			min.	typ.	max.	
Kollektor-Emitter Sättigungsspannung collector-emitter saturation voltage	$I_C = 800\text{ A}, V_{GE} = 15V, T_{vj} = 25^\circ\text{C}$	$V_{CE\text{ sat}}$	-	3,00	-	V
	$I_C = 800\text{ A}, V_{GE} = 15V, T_{vj} = 125^\circ\text{C}$		-	3,60	-	V
Gate-Schwellenspannung gate threshold voltage	$I_C = 32\text{ mA}, V_{CE} = V_{GE}, T_{vj} = 25^\circ\text{C}$	$V_{GE(th)}$	4,5	5,5	6,5	V
Eingangskapazität input capacitance	$f = 1\text{ MHz}, T_{vj} = 25^\circ\text{C}, V_{CE} = 25V, V_{GE} = 0V$	C_{ies}	-	52	-	nF
Rückwirkungskapazität reverse transfer capacitance	$f = 1\text{ MHz}, T_{vj} = 25^\circ\text{C}, V_{CE} = 25V, V_{GE} = 0V$	C_{res}	-	t.b.d.	-	nF
Gateladung gate charge	$V_{GE} = -15V \dots + 15V, V_{CE} = 600V$	Q_G	-	8,4	-	μC
Kollektor-Emitter Reststrom collector-emitter cut-off current	$V_{CE} = 1200V, V_{GE} = 0V, T_{vj} = 25^\circ\text{C}$	I_{CES}	-	t.b.d.	-	μA
	$V_{CE} = 1200V, V_{GE} = 0V, T_{vj} = 125^\circ\text{C}$		-	t.b.d.	-	mA
Gate-Emitter Reststrom gate-emitter leakage current	$V_{CE} = 0V, V_{GE} = 20V, T_{vj} = 25^\circ\text{C}$	I_{GES}	-	-	400	nA

prepared by: R. Jörke

date of publication : 2000-06-14

approved by: Jens Thureau

revision: 1

Technische Information / Technical Information

IGBT-Module
IGBT-Modules

FZ 800 R12 KS4

eupec



Vorläufige Daten
Preliminary data

Charakteristische Werte / Characteristic values

Transistor / Transistor

			min.	typ.	max.	
Einschaltverzögerungszeit (ind. Last) turn on delay time (inductive load)	$I_C = 800 \text{ A}, V_{CC} = 600 \text{ V}$	$t_{d,on}$	-	100	-	ns
	$V_{GE} = \pm 15 \text{ V}, R_G = 1,3 \Omega, T_{vj} = 25^\circ \text{ C}$ $V_{GE} = \pm 15 \text{ V}, R_G = 1,3 \Omega, T_{vj} = 125^\circ \text{ C}$		-	125	-	ns
Anstiegszeit (induktive Last) rise time (inductive load)	$I_C = 800 \text{ A}, V_{CC} = 600 \text{ V}$	t_r	-	90	-	ns
	$V_{GE} = \pm 15 \text{ V}, R_G = 1,3 \Omega, T_{vj} = 25^\circ \text{ C}$ $V_{GE} = \pm 15 \text{ V}, R_G = 1,3 \Omega, T_{vj} = 125^\circ \text{ C}$		-	100	-	ns
Abschaltverzögerungszeit (ind. Last) turn off delay time (inductive load)	$I_C = 800 \text{ A}, V_{CC} = 600 \text{ V}$	$t_{d,off}$	-	530	-	ns
	$V_{GE} = \pm 15 \text{ V}, R_G = 1,3 \Omega, T_{vj} = 25^\circ \text{ C}$ $V_{GE} = \pm 15 \text{ V}, R_G = 1,3 \Omega, T_{vj} = 125^\circ \text{ C}$		-	590	-	ns
Fallzeit (induktive Last) fall time (inductive load)	$I_C = 800 \text{ A}, V_{CC} = 600 \text{ V}$	t_f	-	60	-	ns
	$V_{GE} = \pm 15 \text{ V}, R_G = 1,3 \Omega, T_{vj} = 25^\circ \text{ C}$ $V_{GE} = \pm 15 \text{ V}, R_G = 1,3 \Omega, T_{vj} = 125^\circ \text{ C}$		-	70	-	ns
Einschaltverlustenergie pro Puls turn-on energy loss per pulse	$I_C = 800 \text{ A}, V_{CC} = 600 \text{ V}, V_{GE} = 15 \text{ V}$ $R_G = 1,3 \Omega, T_{vj} = 125^\circ \text{ C}, L_S = 60 \text{ nH}$	E_{on}	-	76	-	mWs
Abschaltverlustenergie pro Puls turn-off energy loss per pulse	$I_C = 800 \text{ A}, V_{CC} = 600 \text{ V}, V_{GE} = 15 \text{ V}$ $R_G = 1,3 \Omega, T_{vj} = 125^\circ \text{ C}, L_S = 60 \text{ nH}$	E_{off}	-	64	-	mWs
Kurzschlußverhalten SC Data	$t_p \leq 10 \mu\text{sec}, V_{GE} \leq 15 \text{ V}$ $T_{vj} \leq 125^\circ \text{ C}, V_{CC} = 900 \text{ V}, V_{CEmax} = V_{CES} - L_{sCE} \cdot di/dt$	I_{SC}	-	6000	-	A
Modulinduktivität stray inductance module		L_{sCE}	-	12	-	nH
Modul-Leitungswiderstand, Anschlüsse - Chip lead resistance, terminals - chip		R_{CC+EE}	-	t.b.d.	-	mΩ

Charakteristische Werte / Characteristic values

Diode / Diode

			min.	typ.	max.	
Durchlaßspannung forward voltage	$I_F = 800 \text{ A}, V_{GE} = 0 \text{ V}, T_{vj} = 25^\circ \text{ C}$	V_F	-	2,00	-	V
	$I_F = 800 \text{ A}, V_{GE} = 0 \text{ V}, T_{vj} = 125^\circ \text{ C}$		-	1,70	-	V
Rückstromspitze peak reverse recovery current	$I_F = 800 \text{ A}, -di_F/dt = 8200 \text{ A}/\mu\text{sec}$	I_{RM}	-	540	-	A
	$V_R = 600 \text{ V}, V_{GE} = -10 \text{ V}, T_{vj} = 25^\circ \text{ C}$ $V_R = 600 \text{ V}, V_{GE} = -10 \text{ V}, T_{vj} = 125^\circ \text{ C}$		-	900	-	A
Sperrverzögerungsladung recovered charge	$I_F = 800 \text{ A}, -di_F/dt = 8200 \text{ A}/\mu\text{sec}$	Q_r	-	60	-	μAs
	$V_R = 600 \text{ V}, V_{GE} = -10 \text{ V}, T_{vj} = 25^\circ \text{ C}$ $V_R = 600 \text{ V}, V_{GE} = -10 \text{ V}, T_{vj} = 125^\circ \text{ C}$		-	160	-	μAs
Abschaltenergie pro Puls reverse recovery energy	$I_F = 800 \text{ A}, -di_F/dt = 8200 \text{ A}/\mu\text{sec}$	E_{rec}	-	32	-	mWs
	$V_R = 600 \text{ V}, V_{GE} = -10 \text{ V}, T_{vj} = 25^\circ \text{ C}$ $V_R = 600 \text{ V}, V_{GE} = -10 \text{ V}, T_{vj} = 125^\circ \text{ C}$		-	76	-	mWs

Technische Information / Technical Information

IGBT-Module
IGBT-Modules

FZ 800 R12 KS4

eupec



Vorläufige Daten Preliminary data

Thermische Eigenschaften / Thermal properties

			min.	typ.	max.	
Innerer Wärmewiderstand thermal resistance, junction to case	Transistor / transistor, DC	R_{thJC}	-	-	0,018	K/W
	Diode/Diode, DC		-	-	0,027	K/W
Übergangs-Wärmewiderstand thermal resistance, case to heatsink	pro Modul / per module $\lambda_{paste} = 1 \text{ W/m}^2\text{K} / \lambda_{grease} = 1 \text{ W/m}^2\text{K}$	R_{thCK}	-	0,008	-	K/W
Höchstzulässige Sperrschichttemperatur maximum junction temperature		T_{vj}	-	-	150	°C
Betriebstemperatur operation temperature		T_{op}	-40	-	125	°C
Lagertemperatur storage temperature		T_{stg}	-40	-	150	°C

Mechanische Eigenschaften / Mechanical properties

Gehäuse, siehe Anlage case, see appendix					
Material Modulgrundplatte material of module baseplate				Cu	
Innere Isolation internal insulation				AlN	
Kriechstrecke creepage distance				32,2	mm
Luftstrecke clearance				19,1	mm
CTI comperative tracking index				> 400	
Anzugsdrehmoment f. mech. Befestigung mounting torque		M1	4,25	5,75	Nm
Anzugsdrehmoment f. elektr. Anschlüsse terminal connection torque		terminals M4	1,7	2,3	Nm
		terminals M8	8	10,00	Nm
Gewicht weight		G		1000	g

Mit dieser technischen Information werden Halbleiterbauelemente spezifiziert, jedoch keine Eigenschaften zugesichert. Sie gilt in Verbindung mit den zugehörigen Technischen Erläuterungen.

This technical information specifies semiconductor devices but promises no characteristics. It is valid in combination with the belonging technical notes.

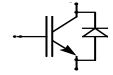

Vorläufige Daten
Preliminary data

Ausgangskennlinie (typisch)
Output characteristic (typical)

$I_C = f(V_{CE})$
 $V_{GE} = 15V$

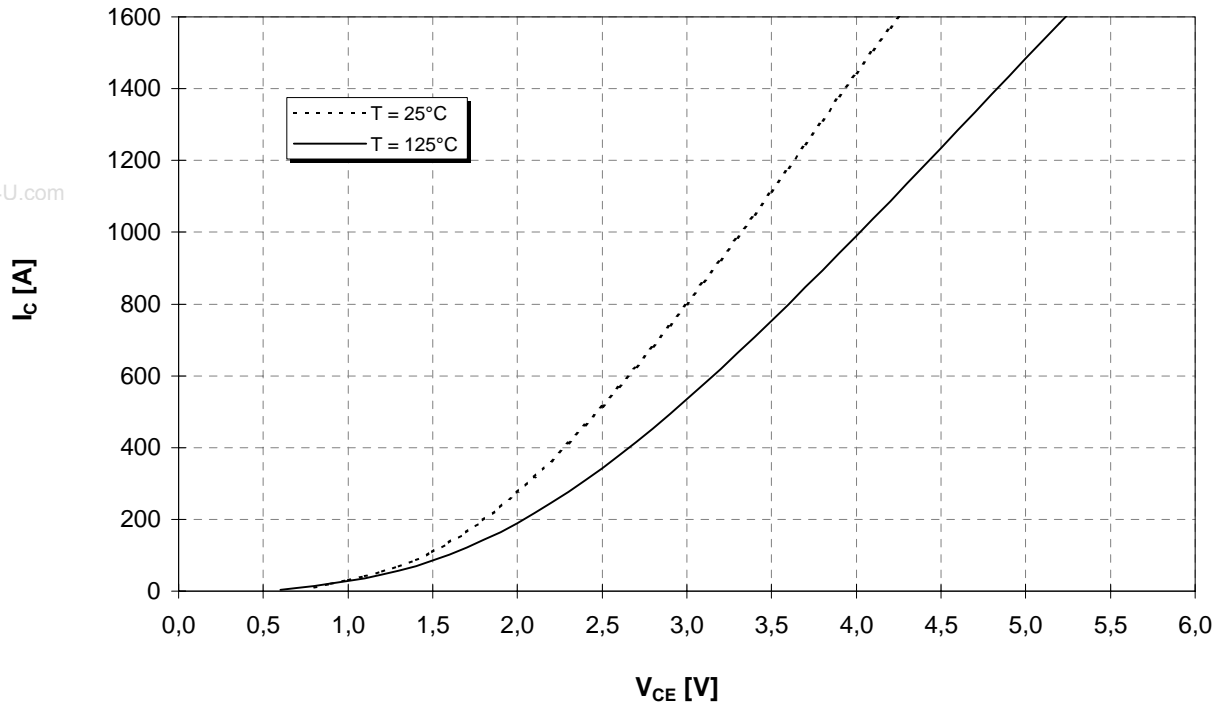

Ausgangskennlinienfeld (typisch)
Output characteristic (typical)

$I_C = f(V_{CE})$
 $T_{vj} = 125°C$

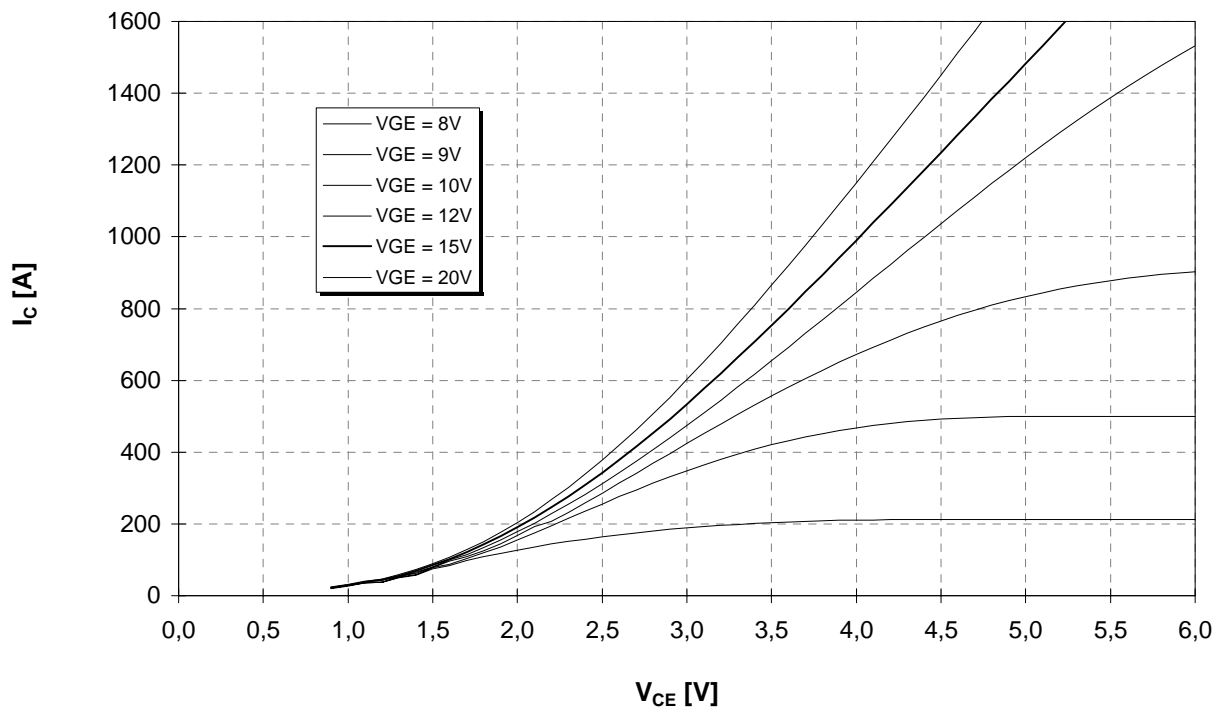

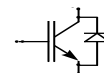

Vorläufige Daten
Preliminary data

Übertragungscharakteristik (typisch)
Transfer characteristic (typical)

$I_C = f(V_{GE})$
 $V_{CE} = 20V$

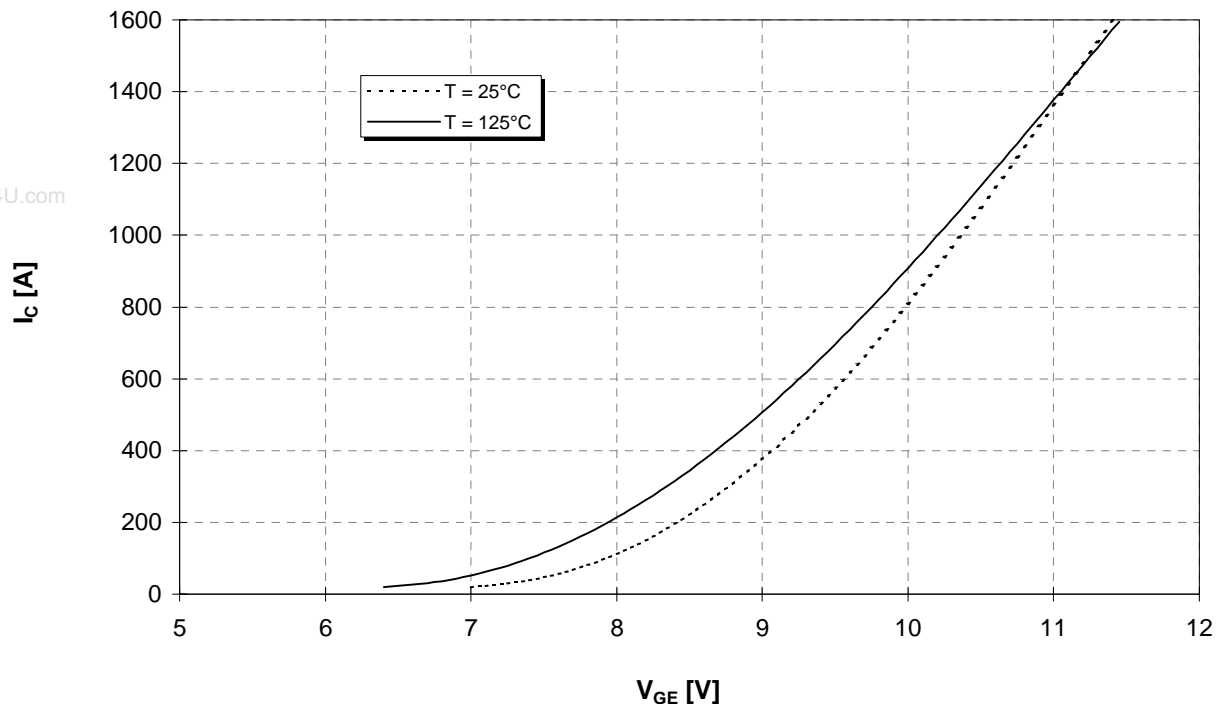

Durchlaßkennlinie der Inversdiode (typisch)
Forward characteristic of inverse diode (typical)

$I_F = f(V_F)$

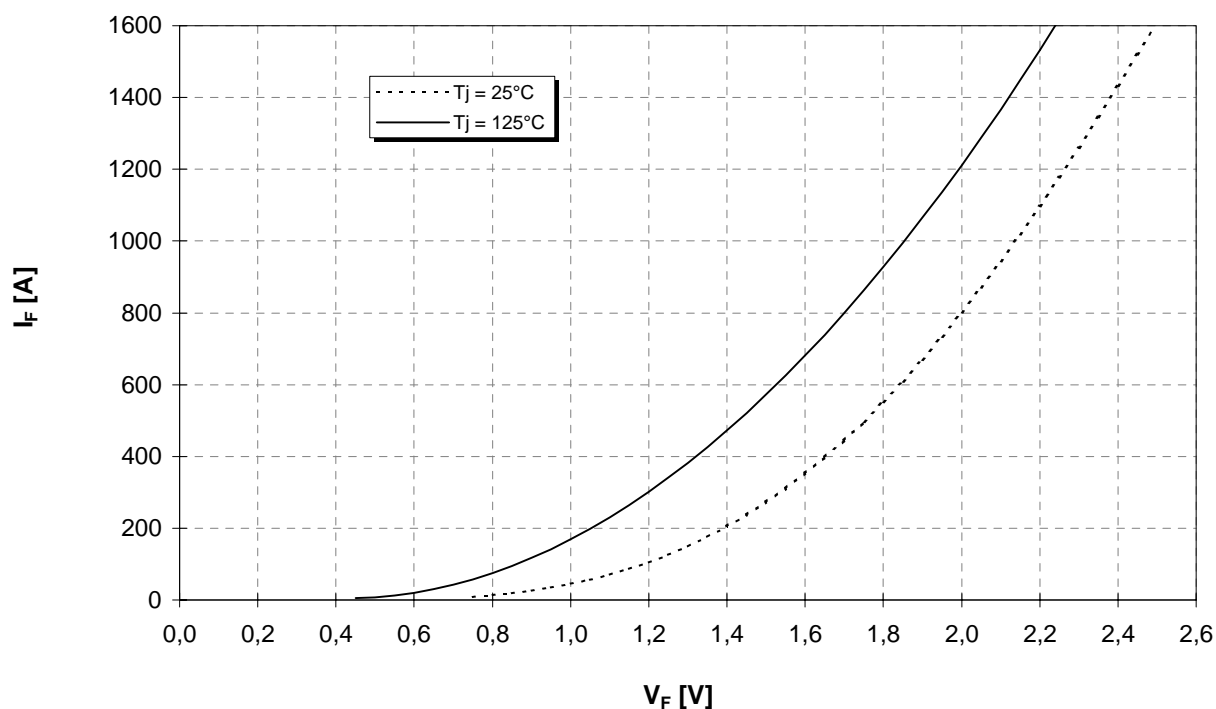

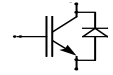

Vorläufige Daten
Preliminary data

Schaltverluste (typisch)
Switching losses (typical)

$$E_{on} = f(I_C), E_{off} = f(I_C), E_{rec} = f(I_C)$$

$R_{G,on} = 1,3 \Omega, R_{G,off} = 1,3 \Omega, V_{CE} = 600V, T_j = 125^\circ C$

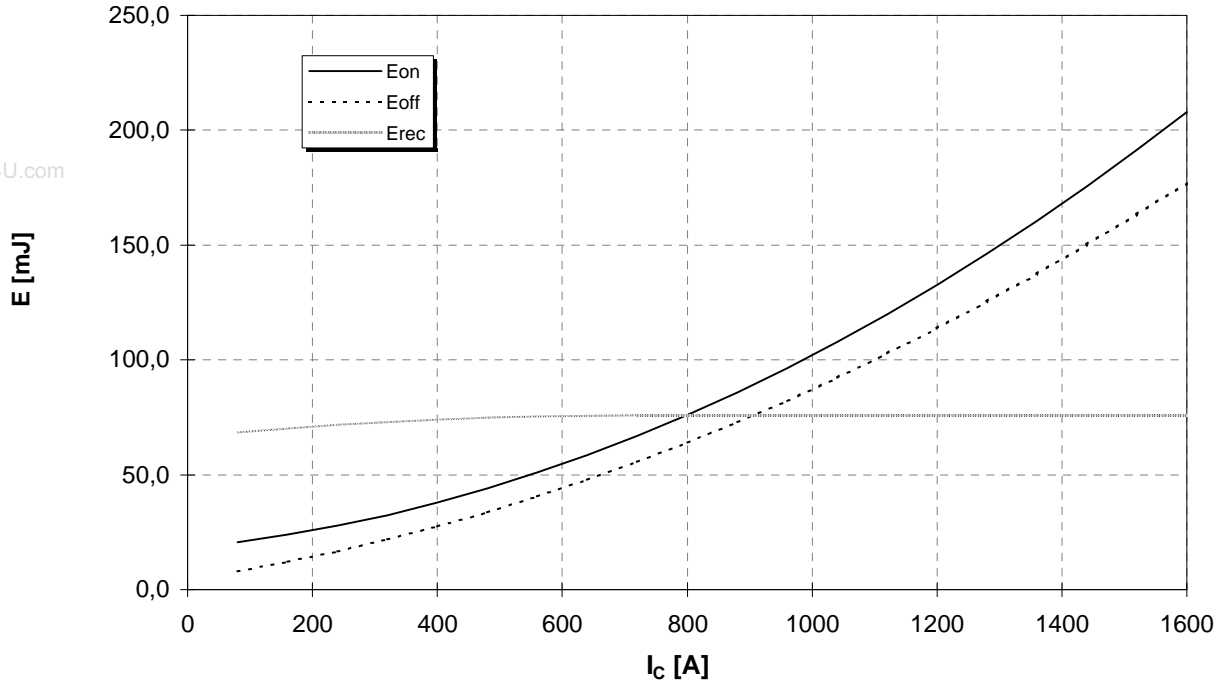

Schaltverluste (typisch)
Switching losses (typical)

$$E_{on} = f(R_G), E_{off} = f(R_G), E_{rec} = f(R_G)$$

$I_C = 800 A, V_{CE} = 600V, T_j = 125^\circ C$

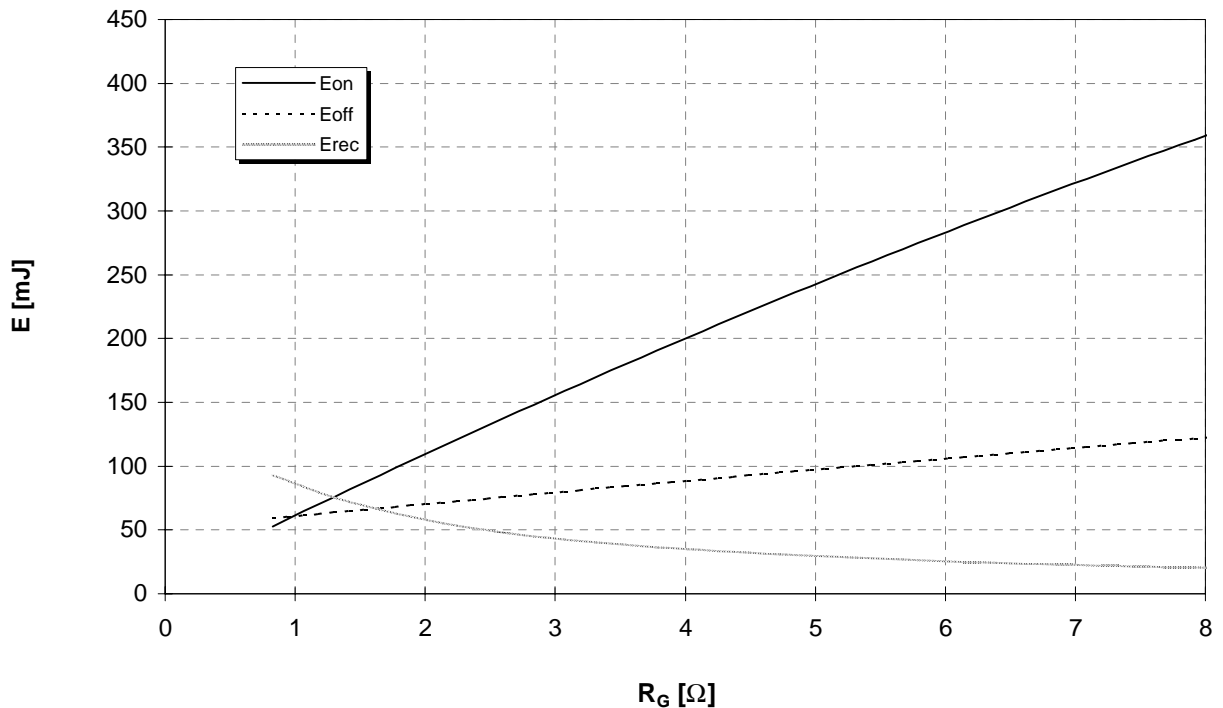

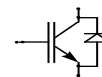

Vorläufige Daten
Preliminary data

Sicherer Arbeitsbereich IGBT (RBSOA) Reverse bias safe operation area IGBT (RBSOA)

$R_{G,off} = 1,3 \Omega$, $T_{vj} = 125^\circ\text{C}$

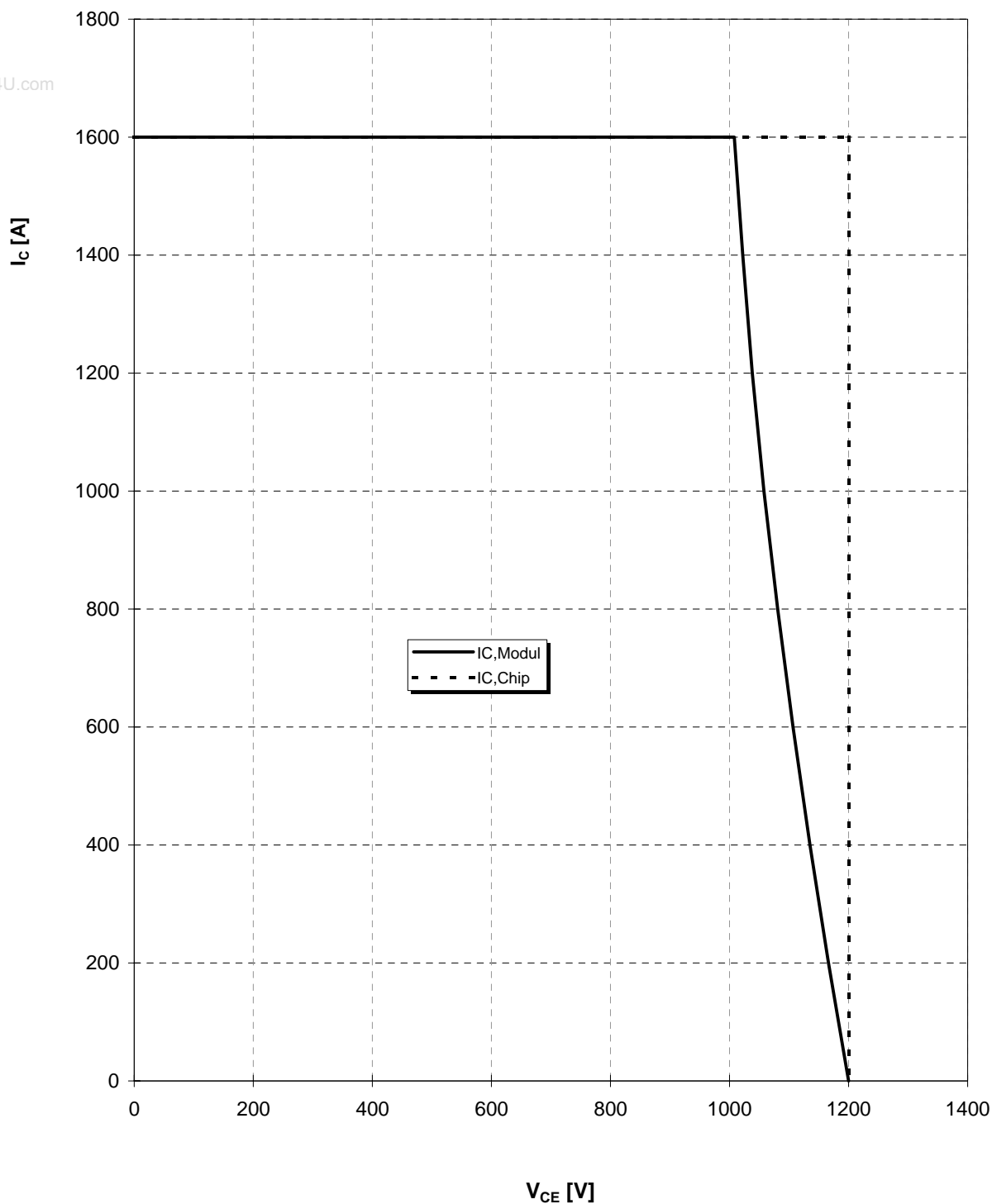

www.DataSheet4U.com

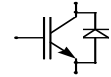

Vorläufige Daten
Preliminary data

Transienter Wärmewiderstand
Transient thermal impedance

$$Z_{thJC} = f(t)$$

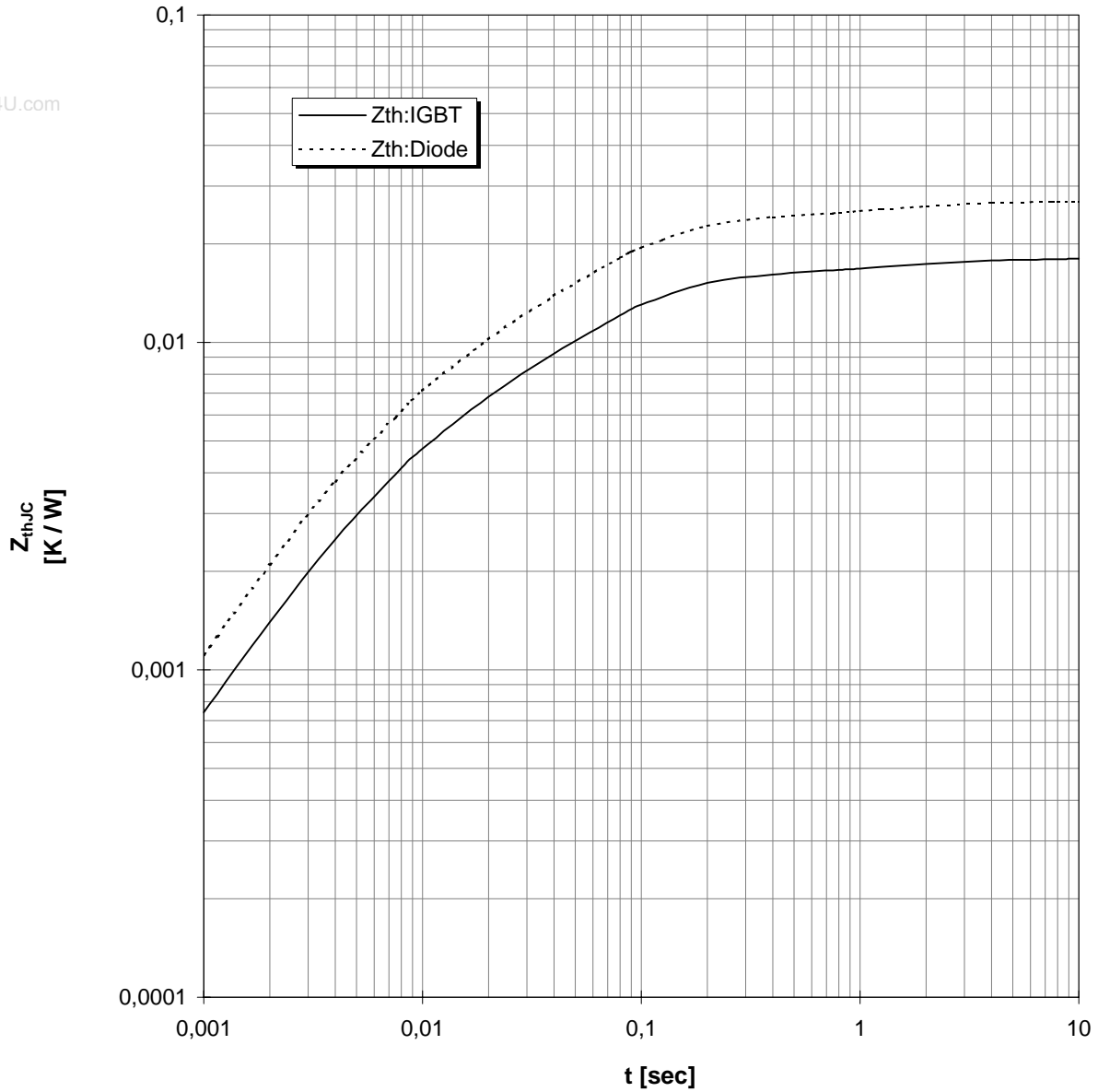

i	1	2	3	4
r_i [K/kW] : IGBT	3,85	5,68	6,15	2,32
τ_i [sec] : IGBT	0,0064	0,0493	0,0916	1,5237
r_i [K/kW] : Diode	5,78	8,52	9,22	3,48
τ_i [sec] : Diode	0,0064	0,0493	0,0916	1,5237

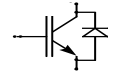

Vorläufige Daten
Preliminary data

Gehäusemaße / Schaltbild
Package outline / Circuit diagram

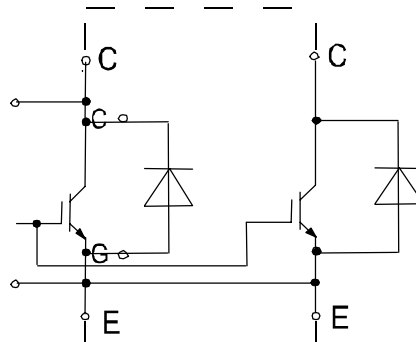
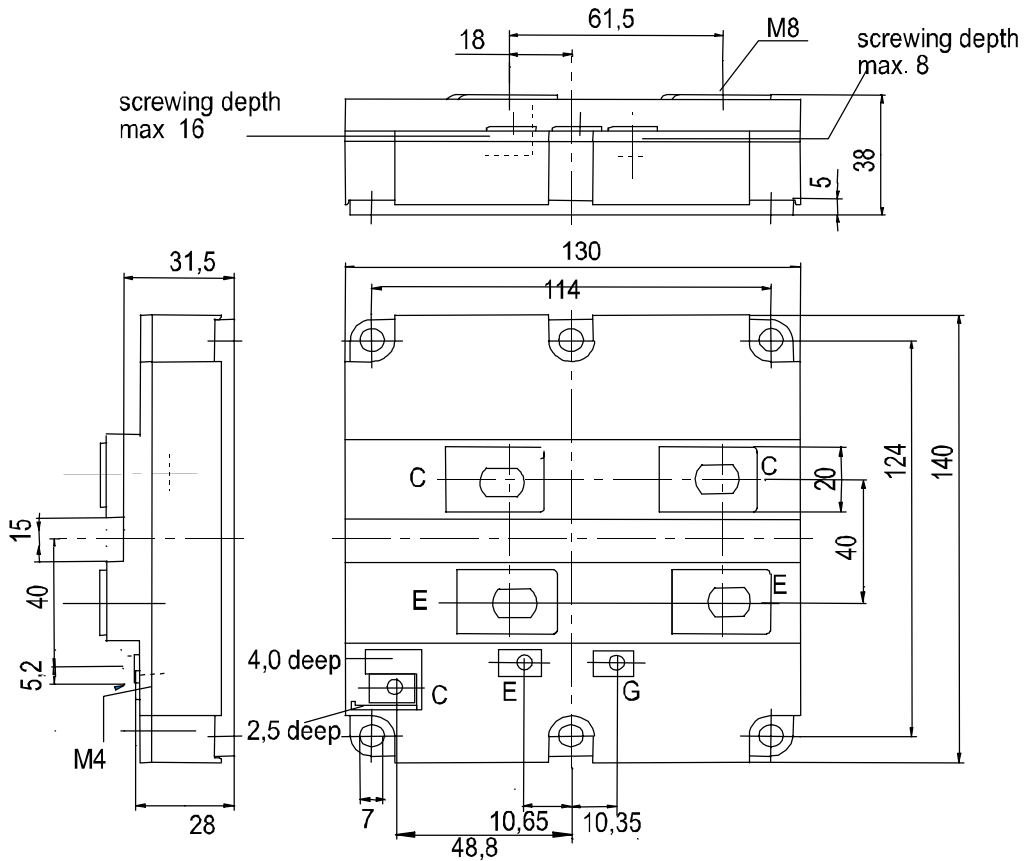

external connection
(to be done)