

Date: March 6, 2006

## Product Specification

**6.5" VGA Color TFT-LCD Module**  
**Model Name: G065VN01**  
**V.0**

**(V) Preliminary Specifications**  
**( ) Final Specifications**

**Note: This Specification is subject to change without notice.**

# Contents

<b>1. Handling Precautions.....</b>	<b>4</b>
<b>2. General Description .....</b>	<b>5</b>
2.1 Display Characteristics .....	5
2.2 Optical Characteristics.....	6
<b>3. Functional Block Diagram .....</b>	<b>10</b>
<b>4. Absolute Maximum Ratings .....</b>	<b>11</b>
4.1 Absolute Ratings of TFT LCD Module .....	11
4.2 Absolute Ratings of Backlight Unit.....	11
4.3 Absolute Ratings of Environment .....	11
<b>5. Electrical Characteristics .....</b>	<b>12</b>
5.1 TFT LCD Module.....	12
5.2 Backlight Unit .....	14
<b>6. Signal Characteristic.....</b>	<b>15</b>
6.1 Pixel Format Image.....	15
6.2 The Input Data Format.....	16
6.3 Signal Description.....	18
6.4 Interface Timing .....	19
6.5 Power ON/OFF Sequence.....	21
<b>7. Connector &amp; Pin Assignment.....</b>	<b>22</b>
7.1 TFT LCD Module: LVDS Connector .....	22
7.2 Backlight Unit: Lamp Connector .....	22
7.3 Lamp Connector Pin Assignment.....	22
<b>8. Reliability, Shock &amp; Vibration Test Criteria .....</b>	<b>23</b>
<b>9. Mechanical Characteristics .....</b>	<b>24</b>
9.1 LCM Outline Dimension (Front View) .....	24
9.2 LCM Outline Dimension (Rear View) .....	25
9.3 Screw Hole Depth and Center Position.....	26

## Record of Revision

Version and Date	Page	Old description	New Description	Remark
0.1 March 6, 2006	All	First edition to all customer		

## 1. Handling Precautions

- 1) Since front polarizer is easily damaged, pay attention not to scratch it.
- 2) Be sure to turn off power supply when inserting or disconnecting from input connector.
- 3) Wipe off water drop immediately. Long contact with water may cause discoloration or spots.
- 4) When the panel surface is soiled, wipe it with absorbent cotton or other soft cloth.
- 5) Since the panel is made of glass, it may break or crack if dropped or bumped on hard surface.
- 6) Since CMOS LSI is used in this module, take care of static electricity and insure human earth when handling.
- 7) Do not open nor modify the Module Assembly.
- 8) Do not press the reflector sheet at the back of the module to any directions.
- 9) In case if a Module has to be put back into the packing container slot after once it was taken out from the container, do not press the center of the CCFL Reflector edge. Instead, press at the far ends of the CFL Reflector edge softly. Otherwise the TFT Module may be damaged.
- 10) At the insertion or removal of the Signal Interface Connector, be sure not to rotate nor tilt the Interface Connector of the TFT Module.
- 11) After installation of the TFT Module into an enclosure (Notebook PC Bezel, for example), do not twist nor bend the TFT Module even momentary. At designing the enclosure, it should be taken into consideration that no bending/twisting forces are applied to the TFT Module from outside. Otherwise the TFT Module may be damaged.
- 12) Cold cathode fluorescent lamp in LCD contains a small amount of mercury. Please follow local ordinances or regulations for disposal.
- 13) Small amount of materials having no flammability grade is used in the LCD module. The LCD module should be supplied by power complied with requirements of Limited Power Source (, IEC60950 or UL1950), or be applied exemption.
- 14) The LCD module is designed so that the CFL in it is supplied by Limited Current Circuit (IEC60950 or UL1950). Do not connect the CFL in Hazardous Voltage Circuit.

## 2. General Description

G065VN01 V0 is a Color Active Matrix Liquid Crystal Display composed of a TFT LCD panel, a driver circuit, and backlight system. The screen format is intended to support the VGA (640(H) x 480(V)) screen and 16.2M (RGB 8-bits) or 262k colors (RGB 6-bits). All input signals are LVDS interface compatible. Inverter card of backlight is not included.

G065VN01 V0 is designed for human machine interface and for industrial display use.

### 2.1 Display Characteristics

The following items are characteristics summary on the table under 25 °C condition:

Items	Unit	Specifications
Screen Diagonal	[inch]	6.5
Active Area	[mm]	132.48(H) x 99.36(V)
Pixels H x V		640x3(RGB) x 480
Pixel Pitch	[mm]	0.069 x 0.207
Pixel Arrangement		R.G.B. Vertical Stripe
Display Mode		TN, Normally White
Typical White Luminance (5 point average)	[cd/m <sup>2</sup> ]	500 typ. (ICFL=5.0mA) 400 typ. (ICFL=3.8mA)
Luminance Uniformity		80% min. (5 points)
Contrast Ratio		450:1 typ.
Response Time	[msec]	26 typ.
Nominal Input Voltage VDD	[Volt]	3.3 typ.
Typical Power Consumption	[Watt]	4.5W (ICFL=5.0mA) 3.84W (ICFL=3.8mA) All black pattern
Weight	[Grams]	210g typ.
Physical Size	[mm]	153.0x 118.0 x 10.7 (typ.)
Electrical Interface		1 channel LVDS
Surface Treatment		Anti-glare, Hardness 3H,
Support Color		16.2M / 262K colors
Temperature Range Operating Storage (Non-Operating)	[°C] [°C]	-10 to +70 -20 to +80
RoHS Compliance		RoHS Compliance

## 2.2 Optical Characteristics

The optical characteristics are measured under stable conditions at 25 °C (Room Temperature):

Item	Unit	Conditions	Min.	Typ.	Max.	Note
White Luminance	[cd/m <sup>2</sup> ]	CCFL 5.0mA 5 points average	TBD	500	-	1,2
		CCFL 3.8 mA 5 points average	TBD	400	-	
Uniformity	%	5 Points	80%			1, 2, 3
		13 Points	60%			
Contrast Ratio			TBD	450	-	
Cross talk	%				TBD	5
Response Time	[msec]	Rising	-	15	19	6
	[msec]	Falling	-	11	16	
	[msec]	Raising + Falling		26	35	
Viewing Angle	[degree]	Horizontal (Right) CR = 10 (Left)	-	70	-	7
	[degree]		-	70	-	
	[degree]	Vertical (Upper) CR = 10 (Lower)	-	60	-	
	[degree]		-	60	-	
Color / Chromaticity Coordinates (CIE 1931)		Red x	TBD	TBD	TBD	
		Red y	TBD	TBD	TBD	
		Green x	TBD	TBD	TBD	
		Green y	TBD	TBD	TBD	
		Blue x	TBD	TBD	TBD	
		Blue y	TBD	TBD	TBD	
		White x	0.293	0.313	0.343	
		White y	0.299	0.329	0.350	

Note 1: 5 points position (Display active area : 132.48mm(W) x 99.36mm(H))

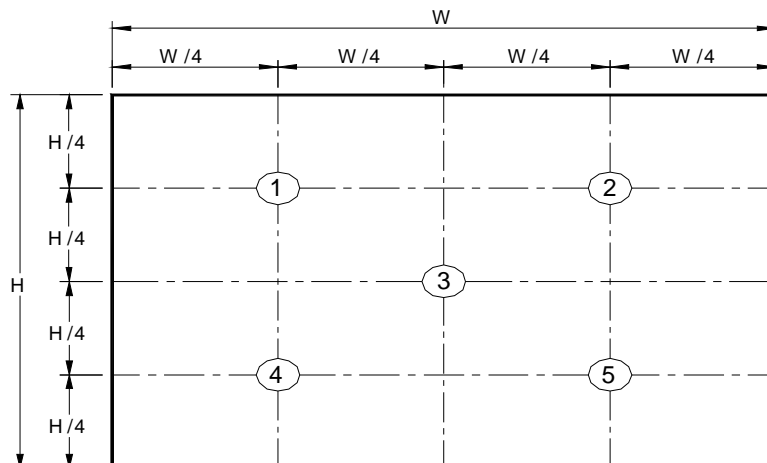

Note 2: 13 points position

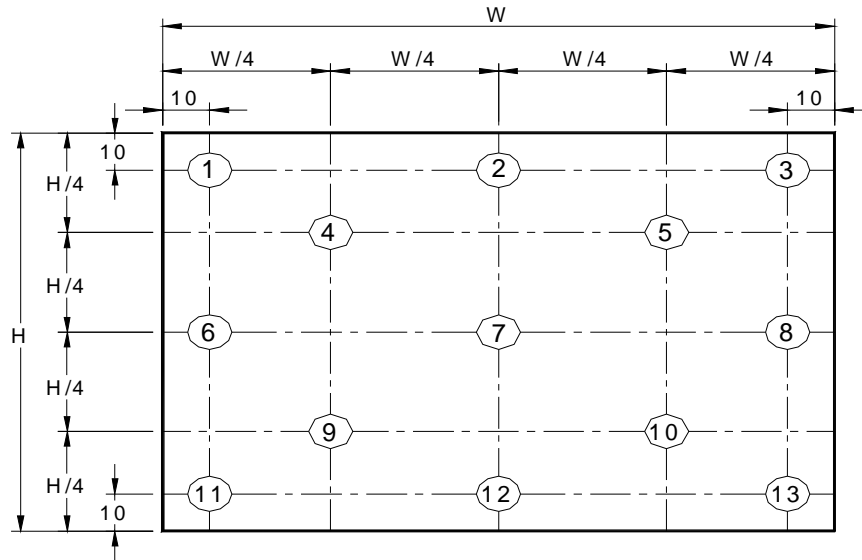

Note 3: The luminance uniformity of 5 and 13 points is defined by dividing the maximum luminance values by the minimum test point luminance

$$\delta_{W5} = \frac{\text{Maximum Brightness of five points}}{\text{Minimum Brightness of five points}}$$

$$\delta_{W13} = \frac{\text{Maximum Brightness of thirteen points}}{\text{Minimum Brightness of thirteen points}}$$

Note 4: Measurement method

The LCD module should be stabilized at given temperature for 30 minutes to avoid abrupt temperature change during measuring. In order to stabilize the luminance, the measurement should be executed after lighting Backlight for 30 minutes in a stable, windless and dark room.

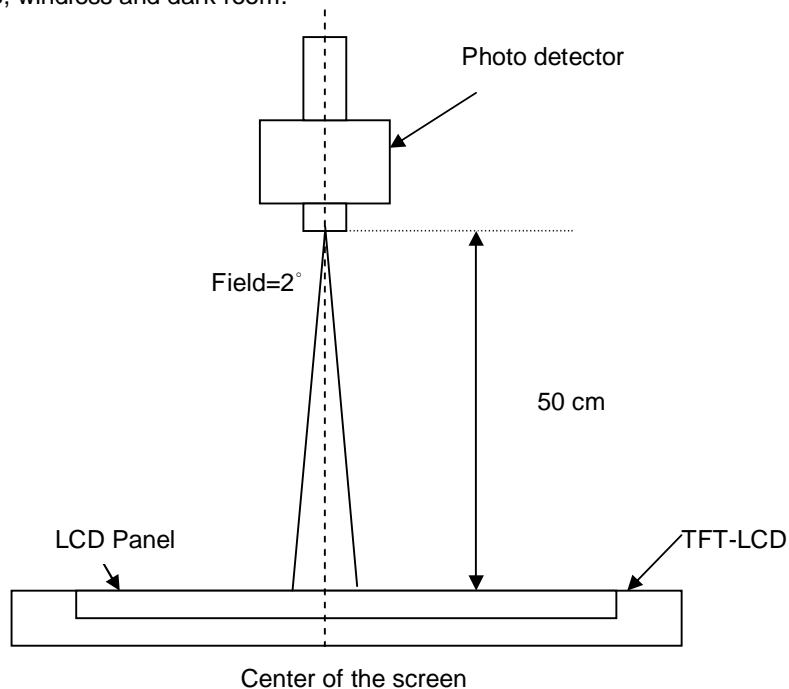

Note 5 : Definition of Cross Talk (CT)

$$CT = |Y_B - Y_A| / Y_A \times 100 (\%)$$

Where

$Y_A$  = Luminance of measured location without gray level 0 pattern (cd/m<sup>2</sup>)

$Y_B$  = Luminance of measured location with gray level 0 pattern (cd/m<sup>2</sup>)

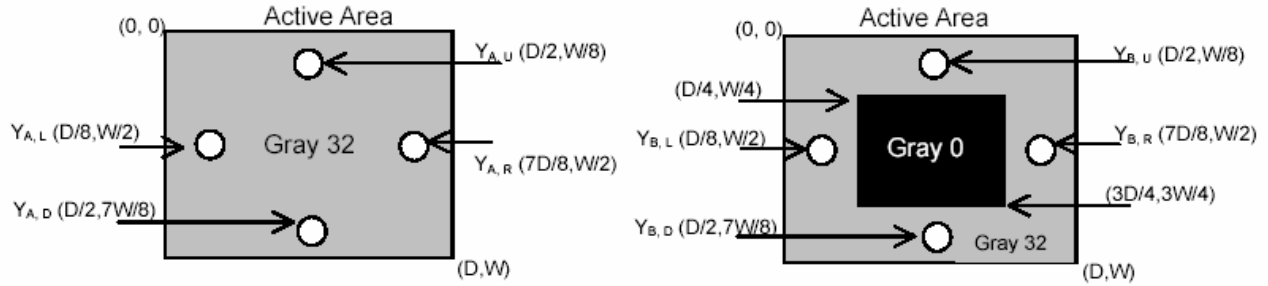

Note 6: Definition of response time:

The output signals of BM-7 or equivalent are measured when the input signals are changed from “Black” to “White” (falling time) and from “White” to “Black” (rising time), respectively. The response time interval between the 10% and 90% of amplitudes. Refer to figure as below.

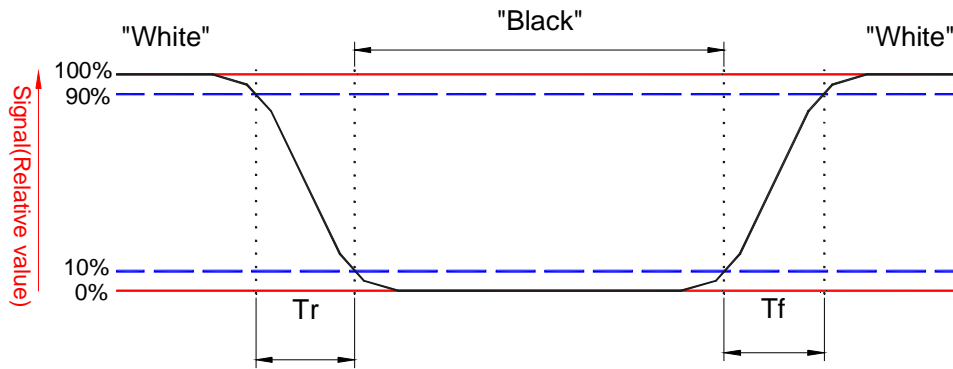



Note 7. Definition of viewing angle

Viewing angle is the measurement of contrast ratio  $\geq 10$ , at the screen center, over a  $180^\circ$  horizontal and  $180^\circ$  vertical range (off-normal viewing angles). The  $180^\circ$  viewing angle range is broken down as follows;  $90^\circ$  ( $\theta$ ) horizontal left and right and  $90^\circ$  ( $\Phi$ ) vertical, high (up) and low (down). The measurement direction is typically perpendicular to the display surface with the screen rotated about its center to develop the desired measurement viewing angle.

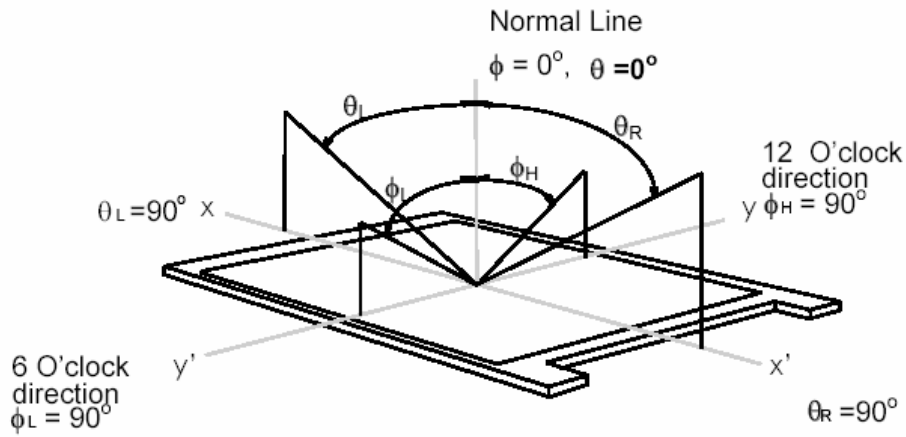

### 3. Functional Block Diagram

The following diagram shows the functional block of the 6.5 inches Color TFT/LCD Module:

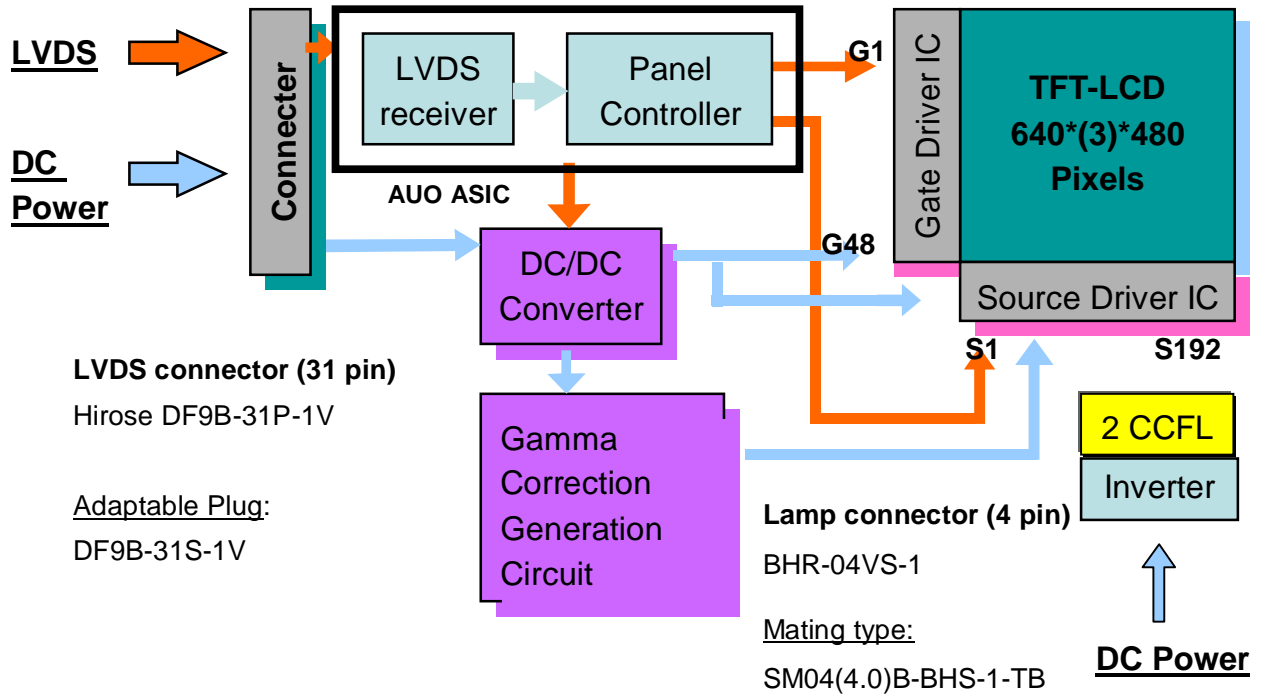

## 4. Absolute Maximum Ratings

Absolute maximum ratings of the module are as below:

### 4.1 Absolute Ratings of TFT LCD Module

Item	Symbol	Min	Max	Unit	Conditions
Logic/LCD Drive	Vin	-0.3	+4.0	[Volt]	Note 1,2

### 4.2 Absolute Ratings of Backlight Unit

Item	Symbol	Min	Max	Unit	Conditions
CCFL Current	ICFL	-	TBD	[mA] rms	Note 1,2

### 4.3 Absolute Ratings of Environment

Item	Symbol	Min	Max	Unit	Conditions
Operating Temperature	TOP	-10	+70	[°C]	Note 3
Operation Humidity	HOP	8	95	[%RH]	Note 3
Storage Temperature	TST	-20	+80	[°C]	Note 3
Storage Humidity	HST	5	95	[%RH]	Note 3

Note 1: With in Ta (25°C )

Note 2: Permanent damage to the device may occur if exceed maximum values

## 5. Electrical Characteristics

### 5.1 TFT LCD Module

#### 5.1.1 Power Specification

Input power specifications are as follows;

Symble	Parameter	Min	Typ	Max	Units	Condition
VDD	Logic/LCD Drive Voltage	3.0	3.3	3.6	[Volt]	
PDD	VDD Power		0.9		[Watt]	Max: All Black Pattern
IDD	IDD Current		270		mA	Max: All Black Pattern
IRush	Inrush Current			TBD	mA	
VDDrp	Allowable Logic/LCD Drive Ripple Voltage			100	[mV] p-p	

Note 1 : Measurement conditions:

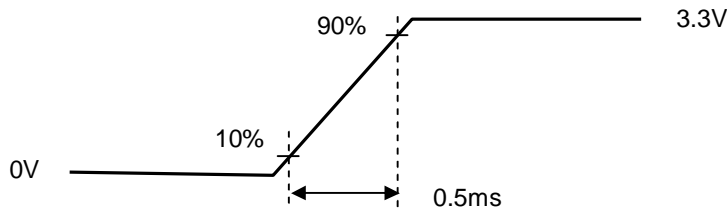
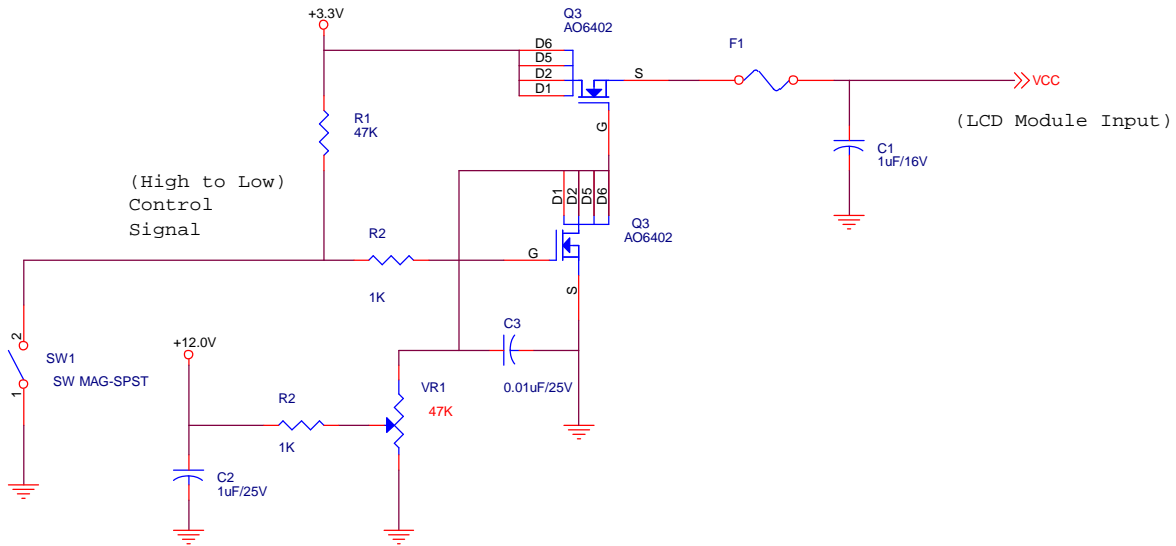

VCC rising time

### 5.1.2 Signal Electrical Characteristics

Input signals shall be low or Hi-Z state when VDD is off.

Item	Symbol	Min.	Typ.	Max.	Unit	Condition
Differential input Voltage	VID	0.25	0.35	0.45	V	
LVDS input common mode voltage	VCM	1.125	1.25	1.375	V	VTH/VTL=±100mV
Differential Input High Threshold Voltage	VTH	-	-	100	mV	VCM=1.25V
Differential Input Low Threshold Voltage	VTL	-100	-	-	mV	

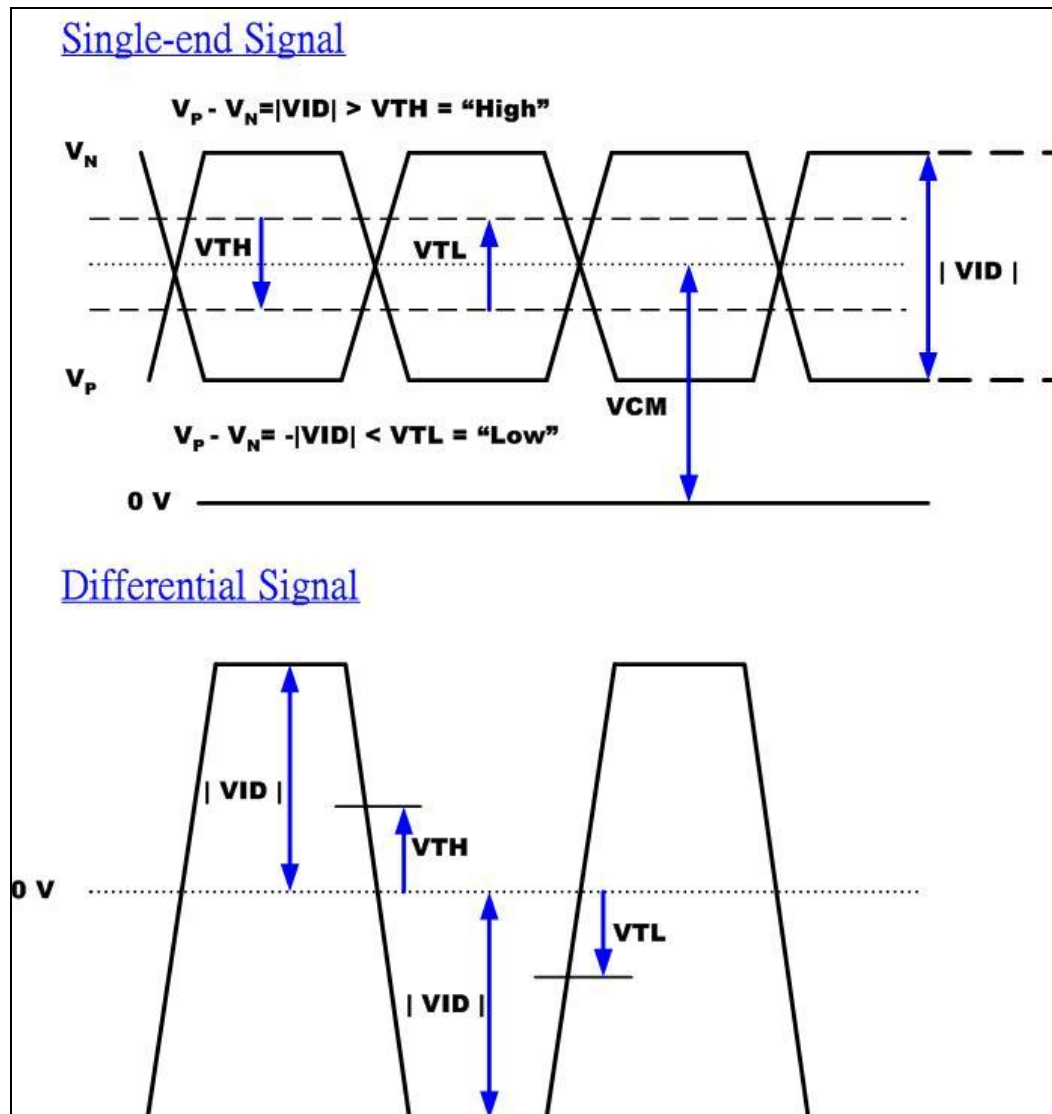

## 5.2 Backlight Unit

Parameter guideline for CCFL Inverter

Parameter	Min	Typ	Max	Units	Condition
White Luminance 5 points average	-	500	-	[cd/m <sup>2</sup> ]	(Ta=25°C) ,ICFL=5mA
	-	400	-		(Ta=25°C) ,ICFL=3.8mA
CCFL current(ICFL)	TBD	5	TBD	[mA] rms	(Ta=25°C) Note 1
CCFL Frequency(FCFL)	50	60	70	[KHz]	(Ta=25°C) Note 2
CCFL Ignition Voltage(Vs)	650	-	-	[Volt] rms	(Ta=25°C)
	1430	-	-		(Ta= -10°C)
CCFL Voltage (Reference) (VCFL)	-	365	-	[Volt] rms	(Ta=25°C) ,ICFL=5mA
	-	386.6	-		(Ta=25°C) ,ICFL=3.8mA
CCFL Power consumption (PCFL)	-	3.65	-	[Watt]	(Ta=25°C) ,ICFL=5mA Note 3
	-	2.94	-		(Ta=25°C) ,ICFL=3.8mA

Note 1: The display is with dual lamp design, and the CCFL current in above table refers to each lamp.

Note 2: CCFL discharge frequency should be carefully determined to avoid interference between inverter and TFT LCD.

Note 3: Calculator value for reference (ICFL×VCFL×2=PCFL)

## 6. Signal Characteristic

### 6.1 Pixel Format Image

Following figure shows the relationship of the input signals and LCD pixel format.

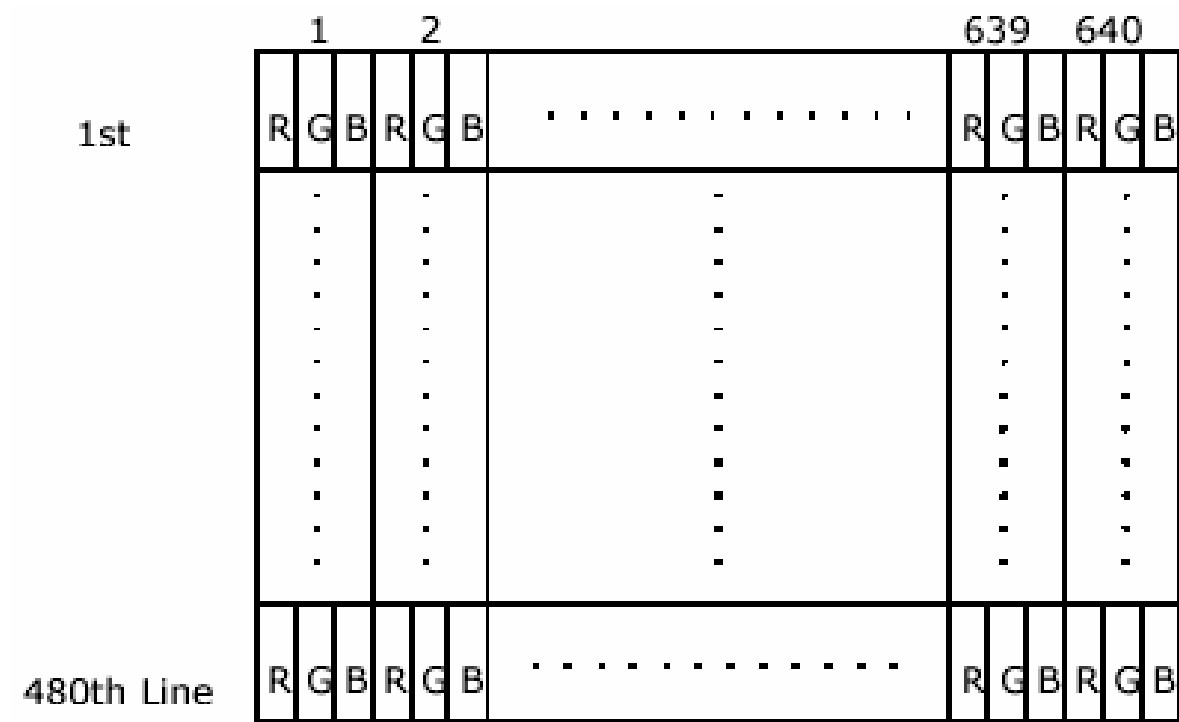

## 6.2 The Input Data Format

**SEL68 = "High" or "NC" for 6 bits LVDS Input**

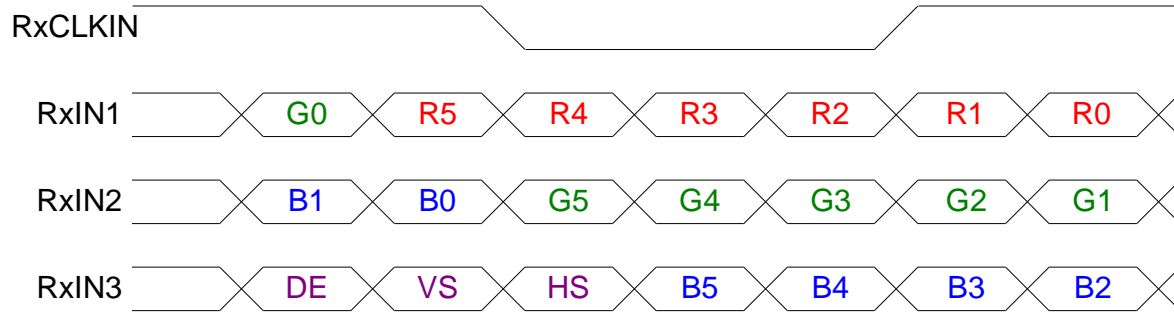

**SEL68 = "Low" for 8 bits LVDS Input**

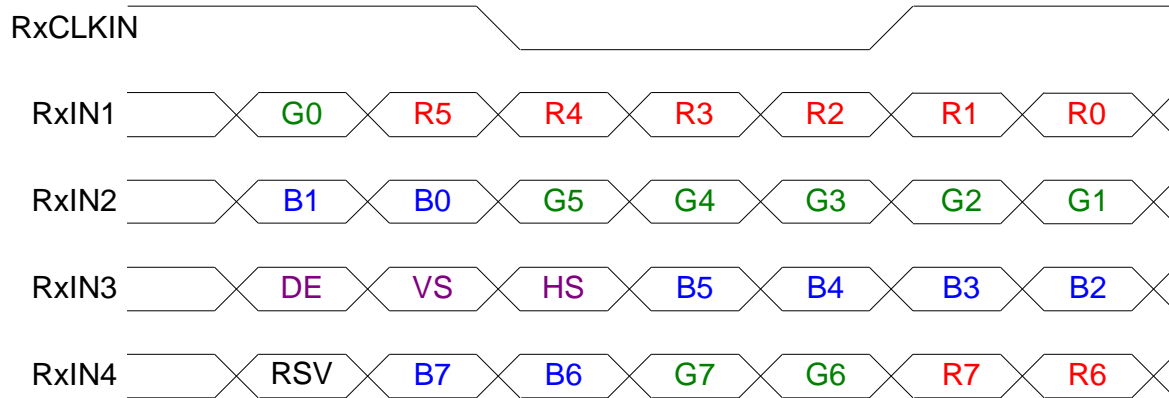



The signal description is listed as following.

Signal Name	Description	Remark
R7	Red Data 7	Red-pixel Data  For 8Bits LVDS input MSB: R7 ; LSB: R0  For 6Bits LVDS input MSB: R5 ; LSB: R0
R6	Red Data 6	
R5	Red Data 5	
R4	Red Data 4	
R3	Red Data 3	
R2	Red Data 2	
R1	Red Data 1	
R0	Red Data 0	
G7	Green Data 7	Green-pixel Data  For 8Bits LVDS input MSB: G7 ; LSB: G0  For 6Bits LVDS input MSB: G5 ; LSB: G0
G6	Green Data 6	
G5	Green Data 5	
G4	Green Data 4	
G3	Green Data 3	
G2	Green Data 2	
G1	Green Data 1	
G0	Green Data 0	
B7	Blue Data 7	Blue-pixel Data  For 8Bits LVDS input MSB: B7 ; LSB: B0  For 6Bits LVDS input MSB: B5 ; LSB: B0
B6	Blue Data 6	
B5	Blue Data 5	
B4	Blue Data 4	
B3	Blue Data 3	
B2	Blue Data 2	
B1	Blue Data 1	
B0	Blue Data 0	
RxCLKIN	LVDS Data Clock	
DE	Data Enable Signal	When the signal is high, the pixel data shall be valid to be displayed.
VS	Vertical Synchronous Signal	
HS	Horizontal Synchronous Signal	

Note: Output signals from any system shall be low or Hi-Z state when VDD is off.

## 6.3 Signal Description

The module uses a LVDS receiver embedded in AUO's ASIC. LVDS is a differential signal technology for LCD interface and high-speed data transfer device.

<i>Pin No.</i>	<i>Symbol</i>	<i>Pin Description</i>
1	GND	Ground
2	GND	Ground
3	RxIN3+	"NC" for 6 Bits LVDS input
4	NC	No connection
5	RxIN3-	"NC" for 6 Bits LVDS input
6	NC	No connection
7	GND	Ground
8	DPS	Selection of scan direction DPS="Low" or "NC", Normal scan. DPS="High", Reverse scan.
9	RxCLKIN+	LVDS differential clock input
10	NC	No connection
11	RxCLKIN-	LVDS differential clock input
12	NC	No connection
13	GND	Ground
14	GND	Ground
15	RxIN2+	LVDS differential input(Blue2-Blue5, Hsync, Vsync, DE)
16	GND	Ground
17	RxIN2-	LVDS differential input(Blue2-Blue5, Hsync, Vsync, DE)
18	NC	No connection
19	GND	Ground
20	NC	No connection
21	RxIN1+	LVDS differential input(Green1-Green5, Blue0, Blue1)
22	NC	No connection
23	RxIN1-	LVDS differential input(Green1-Green5, Blue0, Blue1)
24	NC	No connection
25	GND	Ground
26	SEL68	Selection for either 6 bit or 8bit LVDS input: SEL68="High" or "NC", accepts 6 bits LVDS data input; SEL68="Low", accepts 8 bits LVDS data input.
27	RxIN0+	LVDS differential input(Red0-Red5, Green0)
28	VCC	Power supply
29	RxIN0-	LVDS differential input(Red0-Red5, Green0)
30	VCC	Power supply
31	GND	Ground

**Note:** Input signals shall be in low status when VDD is off.

## 6.4 Interface Timing

### 6.4.1 Timing Characteristics

Parameter		Symbol	Min.	Typ.	Max.	Unit	Condition
Clock frequency		$1/T_{\text{Clock}}$	20	25.2	50	MHz	1,2
Vertical Section	Period	$T_V$	520	525	622	$T_{\text{Line}}$	1,2
	Active	$T_{\text{VD}}$	480	480	480		
	Blanking	$T_{\text{VB}}$	40	45	142		
Horizontal Section	Period	$T_H$	770	800	1070	$T_{\text{Clock}}$	1,2
	Active	$T_{\text{HD}}$	640	640	640		
	Blanking	$T_{\text{HB}}$	130	160	430		

Note 1: Frame rate is 60 Hz.

Note 2: DE mode.

### 6.4.2 Input Timing Diagram

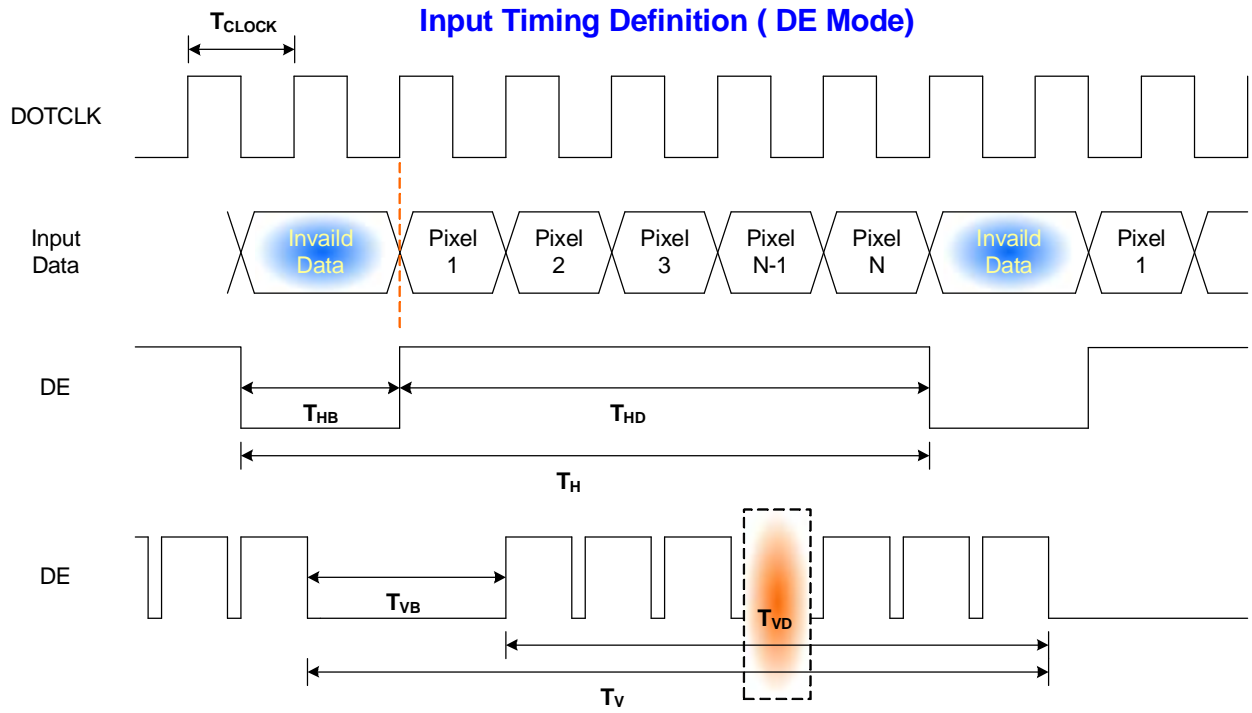

### 6.5 Power ON/OFF Sequence

VDD power and lamp on/off sequence is as follows. Interface signals are also shown in the chart. Signals from any system shall be Hi-Z state or low level when VDD is off.

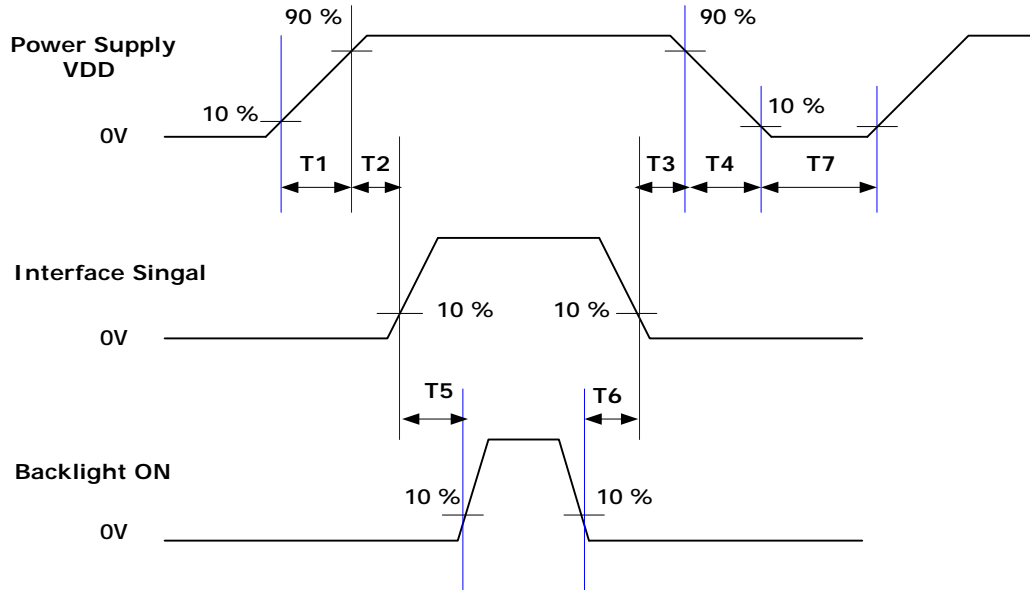

Power ON/OFF sequence timing

Parameter	Value			Units
	Min.	Typ.	Max.	
T1	0.5	-	10	ms
T2	0	-	50	ms
T3	0	-	50	ms
T4	0	-	10	ms
T5	180	-	-	ms
T6	180	-	-	ms
T7	500	-	-	ms

## 7. Connector & Pin Assignment

Physical interface is described as for the connector on module. These connectors are capable of accommodating the following signals and will be following components.

### 7.1 TFT LCD Module: LVDS Connector

<b>Connector Name / Designation</b>	<b>For Signal Connector</b>
Manufacturer	Hirose or compatible
Connector Model Number	DF9B-31P-1V
Adaptable Plug	DF9B-31S-1V

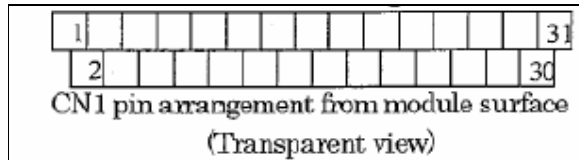

### 7.2 Backlight Unit: Lamp Connector

<b>Connector Name / Designation</b>	<b>For Lamp Connector</b>
Manufacturer	JST or compatible
Connector Model Number	BHR-04VS-1
Mating Model Number	SM04(4.0)B-BHS-1-TB

### 7.3 Lamp Connector Pin Assignment

Pin #	Cable color	Signal Name
4	White	Lamp Low Voltage
3	NC	No Connection
2	Pink	Lamp High Voltage
1	Pink	Lamp High Voltage

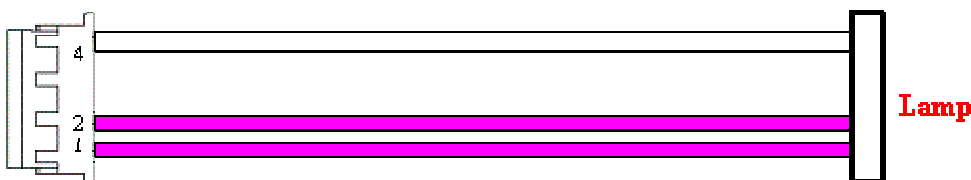

## 8. Reliability, Shock & Vibration Test Criteria

Items	Required Condition	Note
Temperature Humidity Bias	40°C/90%,300Hr	
High Temperature Operation	70°C ,300Hr	
Low Temperature Operation	-10°C ,300Hr	
On/Off Test	25°C ,167hrs(ON/10 sec. OFF/10sec., 30,000 cycles)	
Hot Storage	80°C ,300 hours	
Cold Storage	-20°C ,300 hours	
Thermal Shock Test	-20°C/30 min ,60°C/30 min ,100cycles	
Hot Start Test	70°C/1 Hr min. power on/off per 5 minutes, 5 times	
Cold Start Test	-10°C/1 Hr min. power on/off per 5 minutes, 5 times	
ESD	Contact : ±8KV/ operation, Class B Air : ±15KV / operation, Class B	Note 1
Shock Test (Non-Operating)	50G,11ms,Half-sine wave,(+-X,+-Y,+-Z)	
Vibration Test (Non-Operating)	1.5G, 50~500~50Hz, Sine wave 30mins/axis, 3 direction (X, Y, Z)	

Note1: According to EN61000-4-2 , ESD class B: Some performance degradation allowed. No data lost

. Self-recoverable. No hardware failures.





## 9.2 LCM Outline Dimension (Rear View)

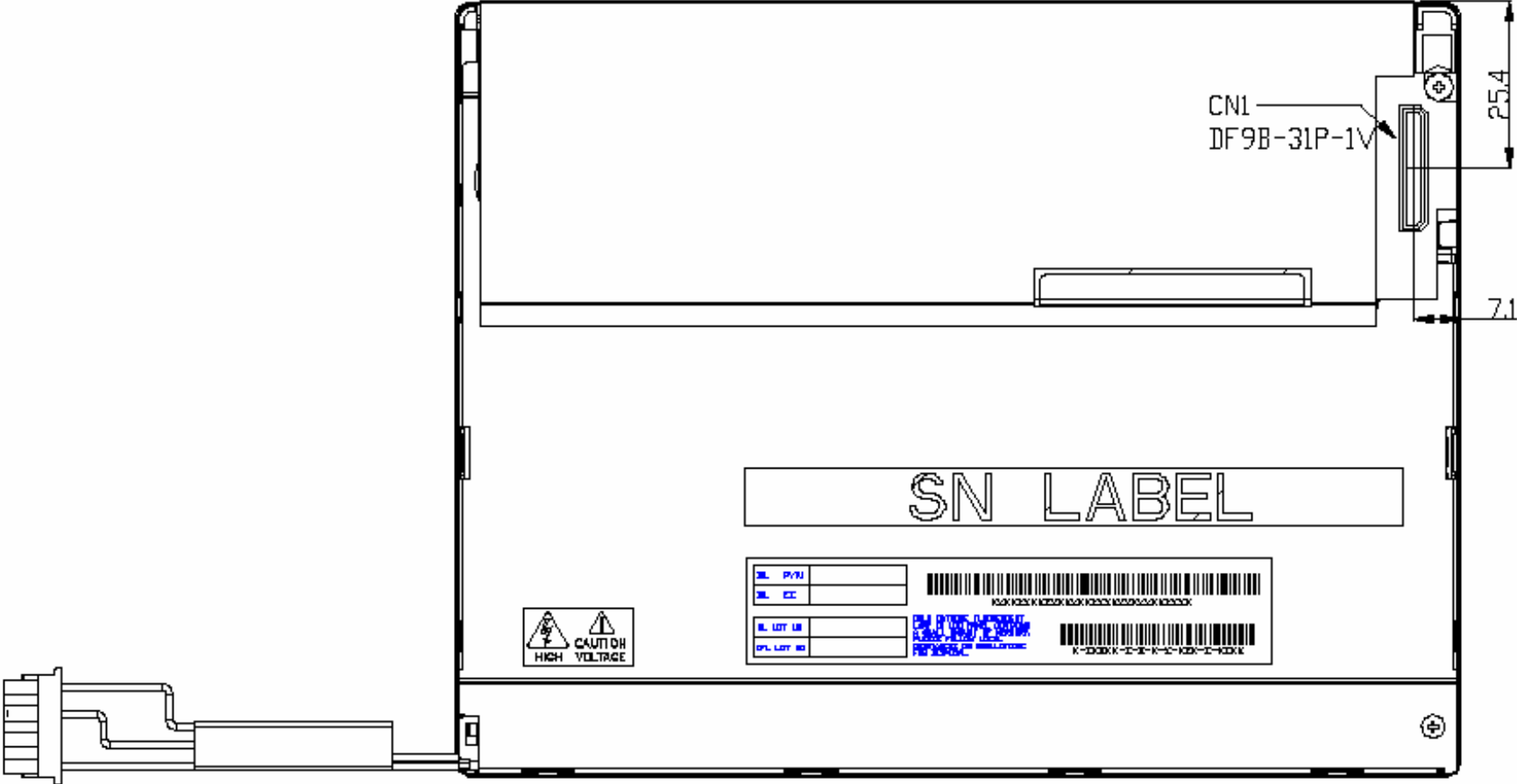

### 9.3 Screw Hole Depth and Center Position

Screw hole minimum depth, from side surface =  $2.5 \pm 0.3\text{mm}$  (See drawing)

Screw hole center location, from front surface =  $3.1 \pm 0.3\text{mm}$  (See drawing)

Screw Torque: Maximum 2.0 kgf-cm

