

CUSTOMER APPROVAL SHEET

Company Name	
MODEL	G070VTN02.0
CUSTOMER APPROVED	Title : Name :

- APPROVAL FOR SPECIFICATIONS ONLY (Spec. Ver. 0.0)
- APPROVAL FOR SPECIFICATIONS AND ES SAMPLE (Spec. Ver.0.0)
- APPROVAL FOR SPECIFICATIONS AND CS SAMPLE (Spec. Ver.0.0)
- CUSTOMER REMARK :

1 Li-Hsin Rd. 2. Science-Based Industrial Park
Hsinchu 300, Taiwan, R.O.C.
Tel: +886-3-500-8899
Fax: +886-3-577-2730

Doc. version :	1.0
Total pages :	21
Date :	2015/05/11

Product Specification

7.0" COLOR TFT-LCD MODULE

Model Name : G070VTN02.0

Planned Lifetime:
Phase-out Control:
EOL Schedule:

< >Preliminary Specification
< ◆ >Final Specification

Note: The content of this specification is subject to change.

© 2015 AU Optronics
All Rights Reserved,
Do Not Copy.

Record of Revision

Version	Revise Date	Page	Content
0.0	2014/09/10	All	First Draft
0.1	2015/01/08	5	Dimension, weight, powe consumption
		6	Outline Dimension
		7	Modify Panel Pin Assignment Description PIN24 : DE → NC PIN25 : HSD → HSD_DE
			Modify Recommended connector
		10	Update Power Consumption
		11	Update Gamma & VCOM voltage suggested circuit
		15	Update Power On/Off Characteristics
		21	Update Shipping label information
0.2	2015/01/12	13	Update Timing characteristics
0.3	2015/03/04	All	Remove watermark of specific customer
		19	Revised wording and format of reliability result
1.0	2015/04/15	5	Update Panel Power Consumption
			Update Weight of Panel
		8	Update Panel pin assignment pin 47 and note
		10	Update Electrical DC Characteristics
		11	Update Gamma & VCOM suggested circuit
		15	Update Power On/Off Characteristics
		16	RGB chromaticity

Contents

A. General Information	5
B. Outline Dimension	6
1. TFT-LCD Modul	6
C. Electrical Specifications	7
1. TFT LCD Panel Pin Assignment	7
2. Backlight Pin Assignment	9
3. Absolute Maximum Ratings	9
4. Electrical DC Characteristics	10
5. TFT- LCD Interface Timing	13
6. Power On/Off Characteristics	15
D. Optical Specification	16
E. Reliability Test Items	19
F. Packing and Marking	20
1. Packing Form	20
2. Module/Panel Label Information	20
G. Precautions	21

AUO Confidential For DATAMODUL Internal Use Only On 2015/10/26

A. General Information

This product is for Marine & Outdoor application.

NO.	Item	Unit	Specification	Remark
1	Screen Size	inch	7.0(Diagonal)	
2	Display Resolution	dot	800RGB(W)x480(H)	
3	Overall Dimension	mm	169.0(H)x103.51(V)x6.22(D)	
4	Active Area	mm	152.4(H)x91.44(V)	
5	Pixel Pitch	mm	0.0635×RGB×0.1905	
6	Color Configuration	--	R. G. B. Stripe	Note 1
7	Color Depth	--	262K Colors	Note 2
8	NTSC Ratio	%	60	
9	Display Mode	--	Normally White	
10	Panel surface Treatment	--	Anti-Glare, 3H	
11	Weight	g	157+/-10%	
12	Panel Power Consumption	mW	Typ. 290	Note 3
13	Backlight Power Consumption	W	Max. 5.44	
14	Viewing direction		6 o'clock (gray inversion)	

Note 1: Below figure shows dot stripe arrangement.

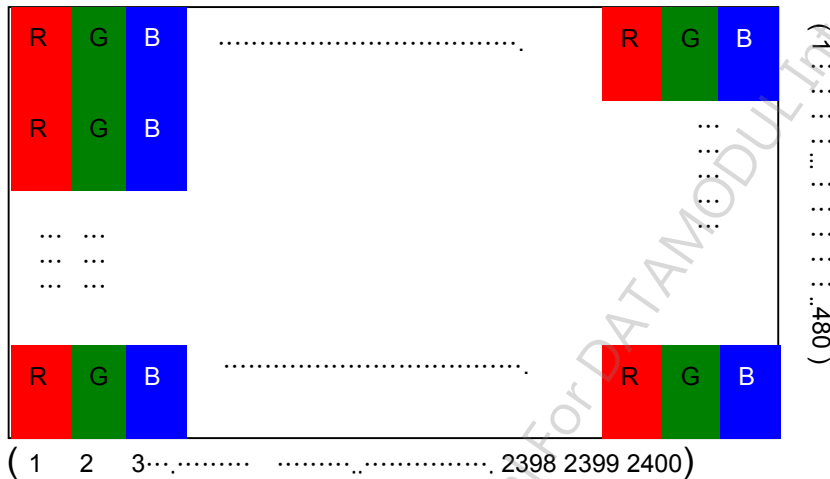

Note 2: The full color display depends on parallel RGB 6 bit data signal.

Note 3: Please refer to Electrical DC Characteristics chapter.

C. Electrical Specifications

1. TFT LCD Panel Pin Assignment

Recommended connector : Omron XF2M-5015-1A

NO.	Symbol	I/O	Description	Remark
1	VCOM	P	Voltage applied to color filter substrate	
2	VGH	P	Gate driver positive voltage	
3	VGL	P	Gate driver negative voltage	
4	VDD	P	Power supply, 3.3V (typical)	
5	GND	P	Ground	
6	V1	I	Voltage for gamma correction	
7	V2	I	Voltage for gamma correction	
8	V3	I	Voltage for gamma correction	
9	V4	I	Voltage for gamma correction	
10	V5	I	Voltage for gamma correction	
11	V6	I	Voltage for gamma correction	
12	V7	I	Voltage for gamma correction	
13	V8	I	Voltage for gamma correction	
14	V9	I	Voltage for gamma correction	
15	V10	I	Voltage for gamma correction	
16	V11	I	Voltage for gamma correction	
17	V12	I	Voltage for gamma correction	
18	V13	I	Voltage for gamma correction	
19	V14	I	Voltage for gamma correction	
20	AVDD	P	Power for source driver IC	
21	AVDD	P	Power for source driver IC	
22	GND	P	Ground	
23	VS	I	Vertical sync input	
24	HSD_DE	I	MODE = H , HSD_DE active high to enable the data input MODE = L, HSD_DE active low for horizontal sync input	
25	NC	-	NC	
26	GND	P	Ground	
27	DCLK	I	Pixel clock	
28	GND	P	Ground	
29	DB5	I	Blue Data Signal (MSB)	
30	DB4	I	Blue Data Signal	
31	DB3	I	Blue Data Signal	
32	DB2	I	Blue Data Signal	

33	DB1	I	Blue Data Signal	
34	DB0	I	Blue Data Signal (LSB)	
35	DG5	I	Green Data Signal (MSB)	
36	DG4	I	Green Data Signal	
37	DG3	I	Green Data Signal	
38	DG2	I	Green Data Signal	
39	DG1	I	Green Data Signal	
40	DG0	I	Green Data Signal (LSB)	
41	DR5	I	Red Data Signal (MSB)	
42	DR4	I	Red Data Signal	
43	DR3	I	Red Data Signal	
44	DR2	I	Red Data Signal	
45	DR1	I	Red Data Signal	
46	DR0	I	Red Data Signal (LSB)	
47	MODE	I	DE / HV Mode select (H : DE Mode , L :HV Mode)	
48	SHLR	I	Horizontal scan direction control	Note
49	UPDN	I	Vertical scan direction control	Note
50	VCOM	P	Voltage applied to color filter substrate	

I: Input pin; P: Power pin; I/O: Input/Output pin

Note.

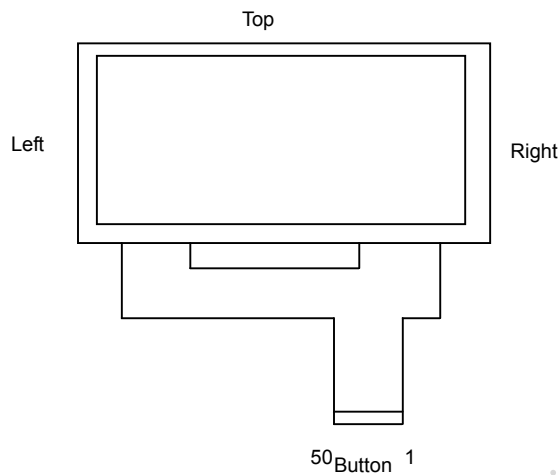

U/D	Direction	L/R	Direction
H	Button -> Top	H	Left->Right
L	Top -> Button	L	Right->Left

2. Backlight Pin Assignment

Recommended connector : STARCONN 089H08-220100-M1-R

Pin no	Symbol	I/O	Description	Remark
1	A1	P	Anode 1	
2	A2	P	Anode 2	
3	N.C	-	No Connection	
4	C1	P	Cathode 1	
5	C2	P	Cathode 2	
6	N.C	-	No Connnection	
7	N.C	-	No Connnection	
8	N.C	-	No Connnection	

P: Power pin

3. Absolute Maximum Ratings

Item	Symbol	Condition	Min.	Max.	Unit	Remark
Power voltage	VDD	GND=0	-0.5	5	V	
	AVDD	GND=0	-0.5	15	V	
	VGH	GND=0	-0.3	40	V	
	VGL		-20	0.3	V	
	VGH – VGL		-	40	V	
Input signal voltage	VI	GND=0	-0.3	VDDIO+0.3	V	Note 1
	VCOM		0	6.5	V	
Operating temperature	Topa		-30	70	°C	
Storage temperature	Tstg		-40	95	°C	

Note 1: Digital Data.

Note 2: Functional operation should be restricted under ambient temperature (25°C).

Note 3: Maximum ratings are those values beyond which damages to the device may occur. Functional operation should be restricted to the limits in the Electrical Characteristics chapter.

4. Electrical DC Characteristics

a. (VDD = +3.3V, AVDD=11V, GND=0V)

Item	Symbol	Min.	Typ.	Max.	Unit	Remark
Power supply	VDD	3.0	3.3	3.6	V	Note3
	IVDD	--	11.6	14	mA	
	AVDD	10.5	11	11.5	V	
	IAVDD	--	22.2	27	mA	
	VGH	19.5	20	20.5	V	
	IVGH	--	0.22	0.3	mA	
	VGL	-10.5	-10	-9.5	V	
	IVGL	--	0.27	0.32	mA	
	VCOM	4.29	4.34	4.39	V	
Input signal	H Level	Vih	0.7×VDDIO	-	VDDIO	Note 1
	L Level	ViL	0	-	0.3×VDDIO	
Input Voltage Reference	V1~V7	0.4*AVDD	-	AVDD-0.2	V	Note 2
	V8~V14	0.2	-	0.6*AVDD	V	Note 2

Note 1 : Digital Data

Note 2 : GND < V14 < V13 < V12 < V11 < V10 < V9 < V8 < V7 < V6 < V5 < V4 < V3 < V2 < V1 < AVDD

Note 3 : Typical current test pattern



b. Gamma voltage suggested circuit is as follows

Recommended voltage setting and resistance for Gamma 2.2

Gamma 2.2				Resistance Value $\pm 1\%$ (Ω)	
Gray Level	AVDD	11.00V			
00H	V1	10.8V	R1	330	
01H	V2	9.86V	R2	1500	
10H	V3	8.75V	R3	1800	
20H	V4	8.06V	R4	1100	
C0H	V5	7.68V	R5	620	
F8H	V6	7.11V	R6	910	
FCH	V7	5.99V	R7	1800	
FCH	V8	5.00V	R8	1600	
F8H	V9	4.07V	R9	1500	
C0H	V10	3.32V	R10	1200	
20H	V11	2.81V	R11	820	
10H	V12	2.13V	R12	1100	
01H	V13	0.89V	R13	2000	
00H	V14	0.20V	R14	1100	
			R15	330	

c. VCOM suggested circuit is as follows

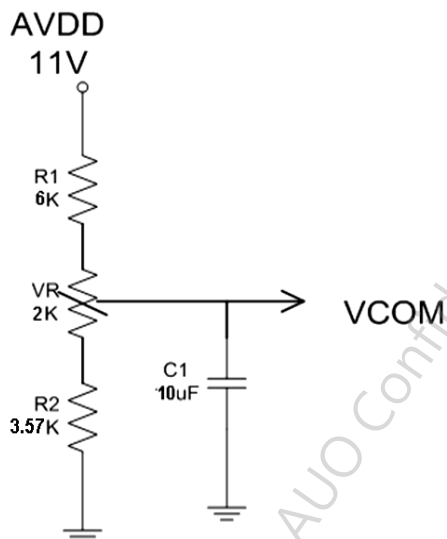

d. Backlight Driving Conditions

Parameter	Symbol	Min.	Typ.	Max.	Unit	Remark
LED Lightbar current	I_L	-	100	-	mA	Single serial (Note 3)
LED Supply Voltage	V_L	-	25.6	27.2	V	Note 3, 25 ° C
LED Lightbar life time		10,000	-	-	Hr	Note 2

Note 1: LED backlight is 16 LEDs (2 strings, 8pcs for each string).

Note 2: The LED lifetime 10000hrs means, after normal use at 100mA, under +25 ° C, the brightness decreases to 50% of original level.

Note 3: The LED supply power is for 2 string of LED.

Note 4: The voltage capacity of LED driver IC must be over max. of LED Voltage.

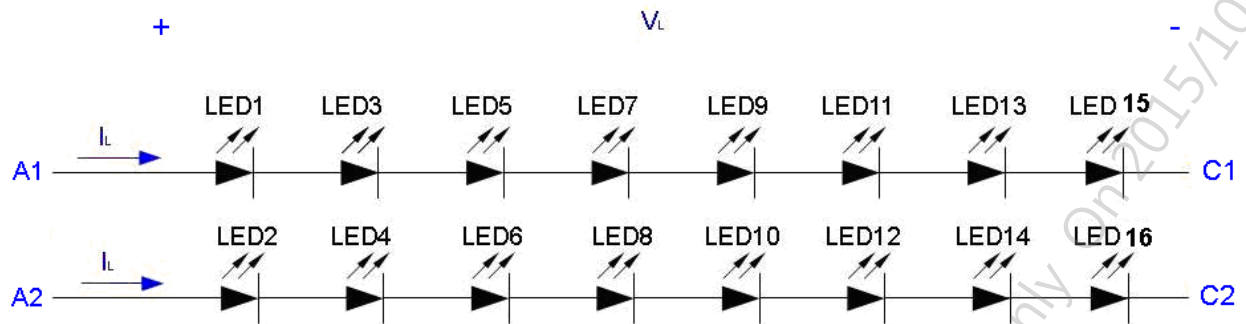

5. TFT- LCD Interface Timing

a. Timing Characteristics

Parameter		Symbol	Min.	Typ.	Max.	Unit.	Remark
DCLK	Frequency	$1/T_{\text{CLOCK}}$	26	30	45	MHz	
	Period	T_{CLOCK}	22.2	33.3	38.4	ns	
Horizontal	Active Time	t_{HD}	800			t_{CLK}	
	HSD pulse width	t_{HPW}	1	48	87	t_{CLK}	DE Mode: THB (HBlanking) $= t_{\text{HPW}} + t_{\text{HBP}} + t_{\text{HFP}}$ HV Mode: $t_{\text{HPW}} + t_{\text{HBP}}$ = 88 DCLK is fixed
	HSD Back porch	t_{HBP}	87	40	1	t_{CLK}	
	HSD Front porch	t_{HFP}	20	40	167	t_{CLK}	
	Frequency	f_{H}	28.4	31.6	44.4	KHz	
	Period	t_{H}	22.5	31.6	35.2	us	
Vertical	Active Time	t_{VD}	480			t_{H}	
	VSD pulse width	T_{VPW}	1	1	3	t_{H}	DE Mode: TVB (VBlanking) = $T_{\text{VPW}} + t_{\text{VBP}} + t_{\text{VFP}}$ HV Mode: $t_{\text{VPW}} + t_{\text{VBP}}$ = 32 DCLK is fixed
	VSD Back porch	T_{VBP}	31	31	29	t_{H}	
	VSD Front porch	T_{VFP}	5	13	168	t_{H}	
	Frequency	f_{V}	55	60	65	Hz	
	Period	t_{V}	15.3	16.6	18.2	ms	

b. Timing Diagram of input (DE Mode)

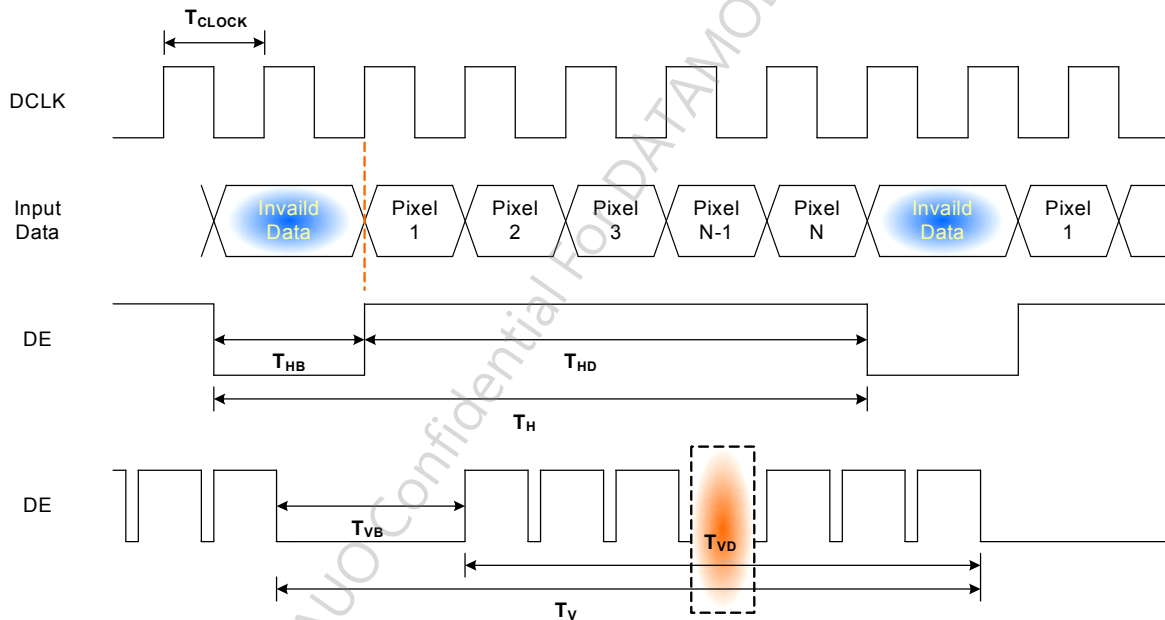

c. Vertical Timing Diagram of Input (HV Mode)

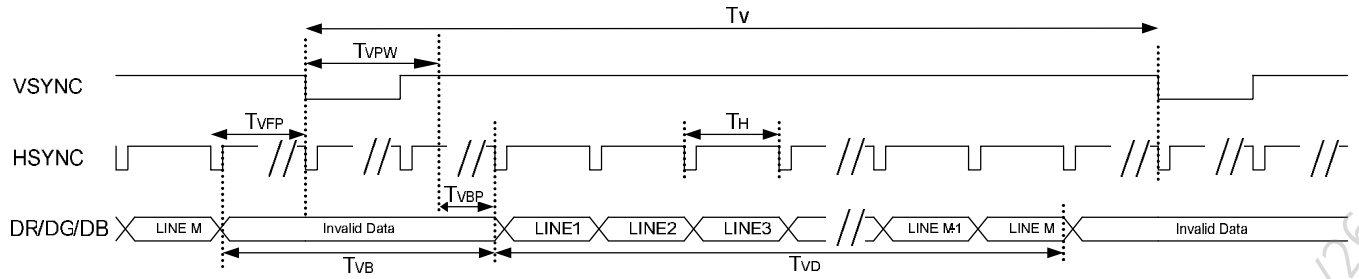

d. Horizontal Timing Diagram of Input (HV Mode)

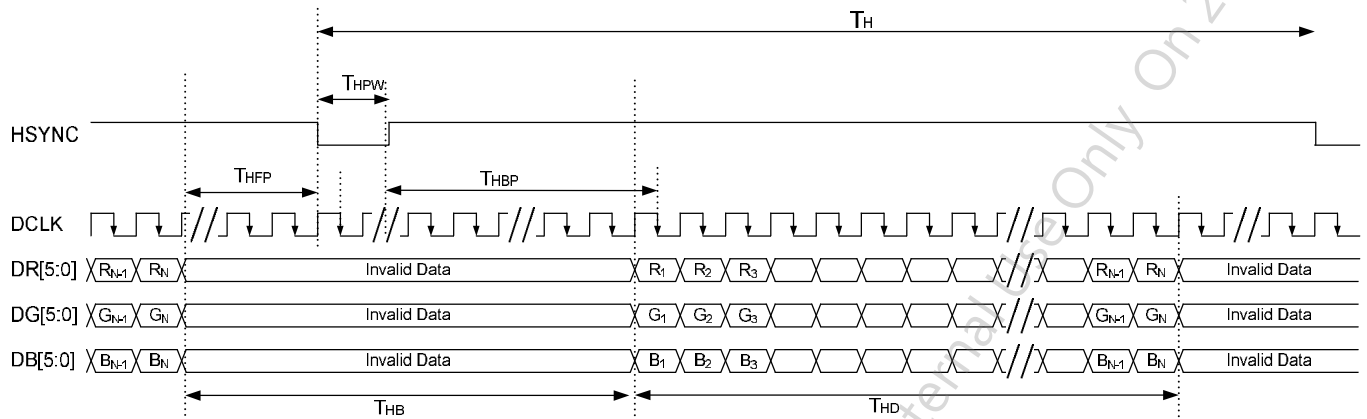

6. Power On/Off Characteristics

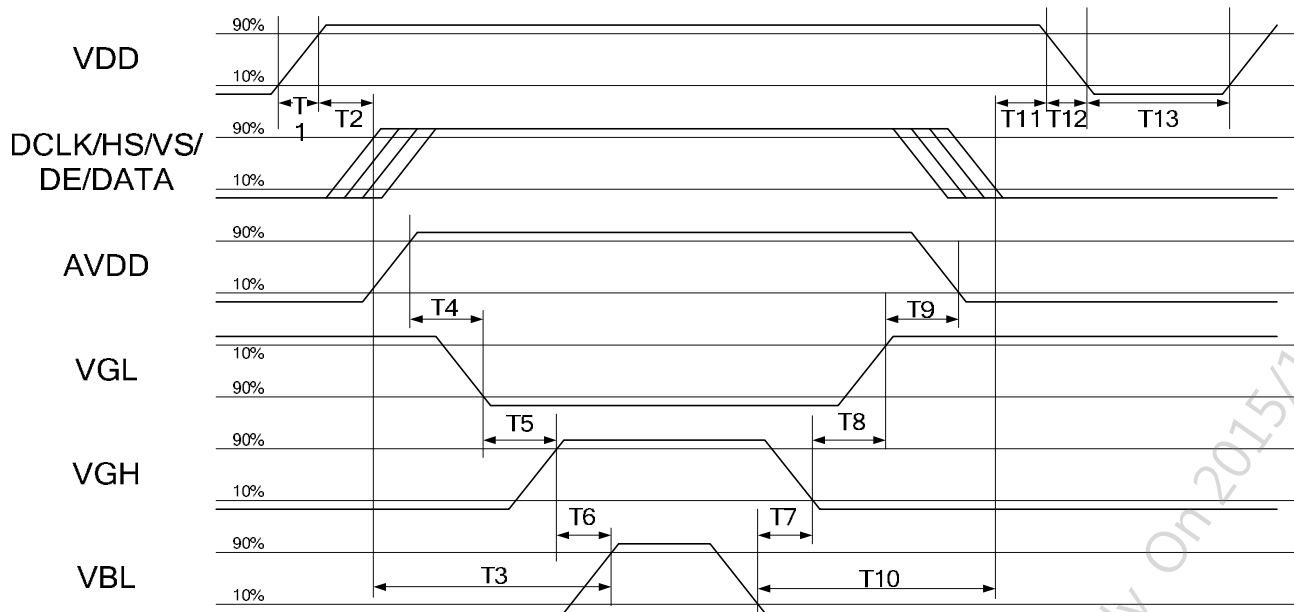

Parameter	Value			Units
	Min.	Typ.	Max.	
T1	0.5	-	20	ms
T2	16	-	50	ms
T3	200	-	-	ms
T4	20	-	40	ms
T5	10	-	30	ms
T6	100	-	-	ms
T7	100	-	-	ms
T8	10	-	30	ms
T9	20	-	40	ms
T10	200	-	-	ms
T11	10	-	50	ms
T12	-	-	10	ms
T13	1000	-	-	ms

D. Optical Specification

All optical specification is measured under typical condition (Note 1)

Item	Symbol	Condition	Min.	Typ.	Max.	Unit	Remark
Response Time							
Rise	Tr	$\theta=0^\circ$	--	12	15	ms	Note 2
Fall	Tf		--	18	25	ms	
Contrast ratio	CR	At optimized viewing angle	400	600	--		Note 3
Viewing Angle		$CR \geq 10$				deg.	Note 4
Top			35	50			
Bottom			45	60			
Left			50	65			
Right		50	65				
Brightness	Y_L	$\theta=0^\circ$	1000	1500	--	cd/m ²	Note 5
Chromaticity	White	x	$\theta=0^\circ$	0.256	0.306	0.356	
		y	$\theta=0^\circ$	0.278	0.328	0.378	
	Red	x	$\theta=0^\circ$	0.576	0.626	0.676	
		y	$\theta=0^\circ$	0.296	0.346	0.396	
	Green	x	$\theta=0^\circ$	0.282	0.332	0.382	
		y	$\theta=0^\circ$	0.562	0.612	0.662	
	Blue	x	$\theta=0^\circ$	0.105	0.155	0.205	
		y	$\theta=0^\circ$	0.012	0.062	0.112	
Uniformity	ΔY_L	%	70	75	--	%	Note 6

Note 1: Ambient temperature =25°C, and LED lightbar currently = 100mA. To be measured in the dark room.

Note 2: Definition of response time:

The output signals of photo detector are measured when the input signals are changed from "black" to "white"(falling time) and from "white" to "black"(rising time), respectively.

The response time is defined as the time interval between the 10% and 90% of amplitudes. Refer to figure as below.

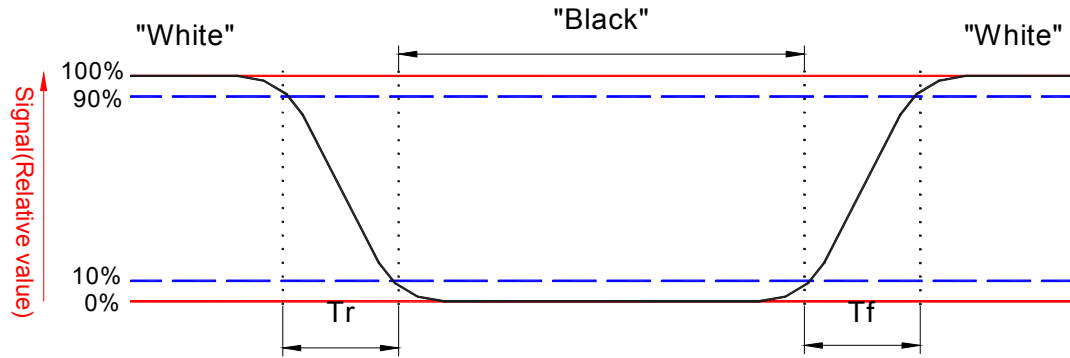

Note 3. Definition of contrast ratio:

Contrast ratio is calculated with the following formula.

$$\text{Contrast ratio (CR)} = \frac{\text{Photo detector output when LCD is at "White" status}}{\text{Photo detector output when LCD is at "Black" status}}$$

Note 4. Definition of viewing angle, Φ , Refer to figure as below.

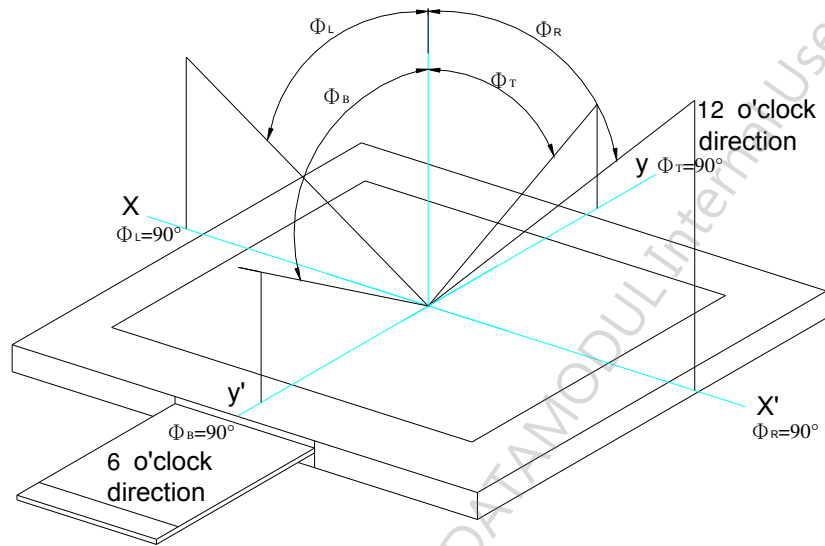

Note 5. Measured at the center area of the panel when all the input terminals of LCD panel are electrically opened.

Note 6. Luminance Uniformity of these 9 points is defined as below:

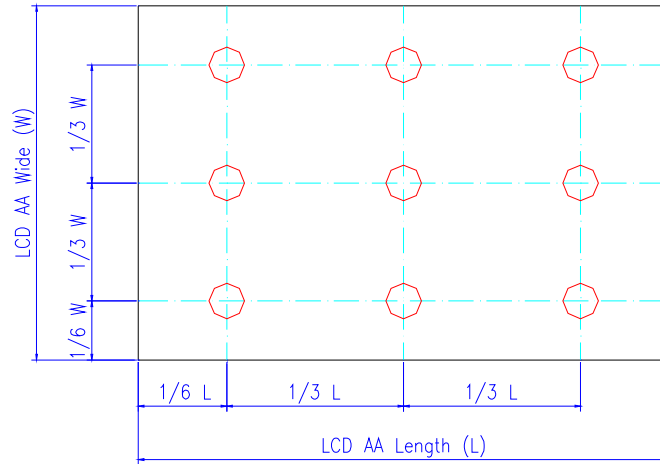

$$\text{Uniformity} = \frac{\text{minimum luminance in 9 points (1-9)}}{\text{maximum luminance in 9 points (1-9)}}$$

AUO Confidential For DATAMODUL Internal Use Only On 2015/10/26

E. Reliability Test Items

Items	Required Condition	Remark
Temperature Humidity Bias	60°C/90%,300Hr	Note 2
High Temperature Operation	70°C,300Hr	Note 2
Low Temperature Operation	-30°C,300Hr	Note 2
High Temperature Storage	95°C,300 hours	Note 2
Low Temperature Storage	-40°C,300 hours	Note 2
Thermal Shock Test	-30°C/30 min ,80°C/30 min ,100cycles	Note 2
Shock Test (Non-Operating)	100G . 6ms, ±X,±Y,±Z 3 times for each direction	Note 2
Vibration Test (Non-Operating)	Frequency range : 8~33.3 HZ Stoke: 1.3mm Sweep: 2.9G, 33.3~400HZ Cycle : 15 mins	Note 2
ESD	Contact Discharge: ±4KV, 150pF(330Ω) 1sec, 8 points, 25 times/point Air Discharge: ±8KV, 150pF(330Ω) 1sec, 8 points, 25 times/point	Note 1,2
On/off test	On/10 sec, Off/10 sec, 30,000 cycles, room temperature	Note 2,3
Drop (With Carton)	Height: 60cm 1 corner, 3 edges, 6 surfaces	Note 2
Vibration (With Carton)	Random vibration: 0.015G ² /Hz from 5~200Hz -6dB/Octave from 200~500Hz	Note 2

Note1: According to EN61000-4-2 ESD class B criteria, some performance degradation is allowed. TFT-LCD module is self-recoverable, no data lost and no hardware failures after test.

Note2:

- Water condensation is not allowed for each test items.
- Each test is done by new TFT-LCD module. Don't use the same TFT-LCD module repeatedly for reliability test.
- The reliability test is performed only to examine the TFT-LCD module capability.
- To inspect TFT-LCD module after reliability test, please store it at room temperature and room humidity for 2 hours at least in advance.

Note3. Judged by the on/off testing results of AUO's standard w/o functional fail.

F. Packing and Marking

1. Packing Form

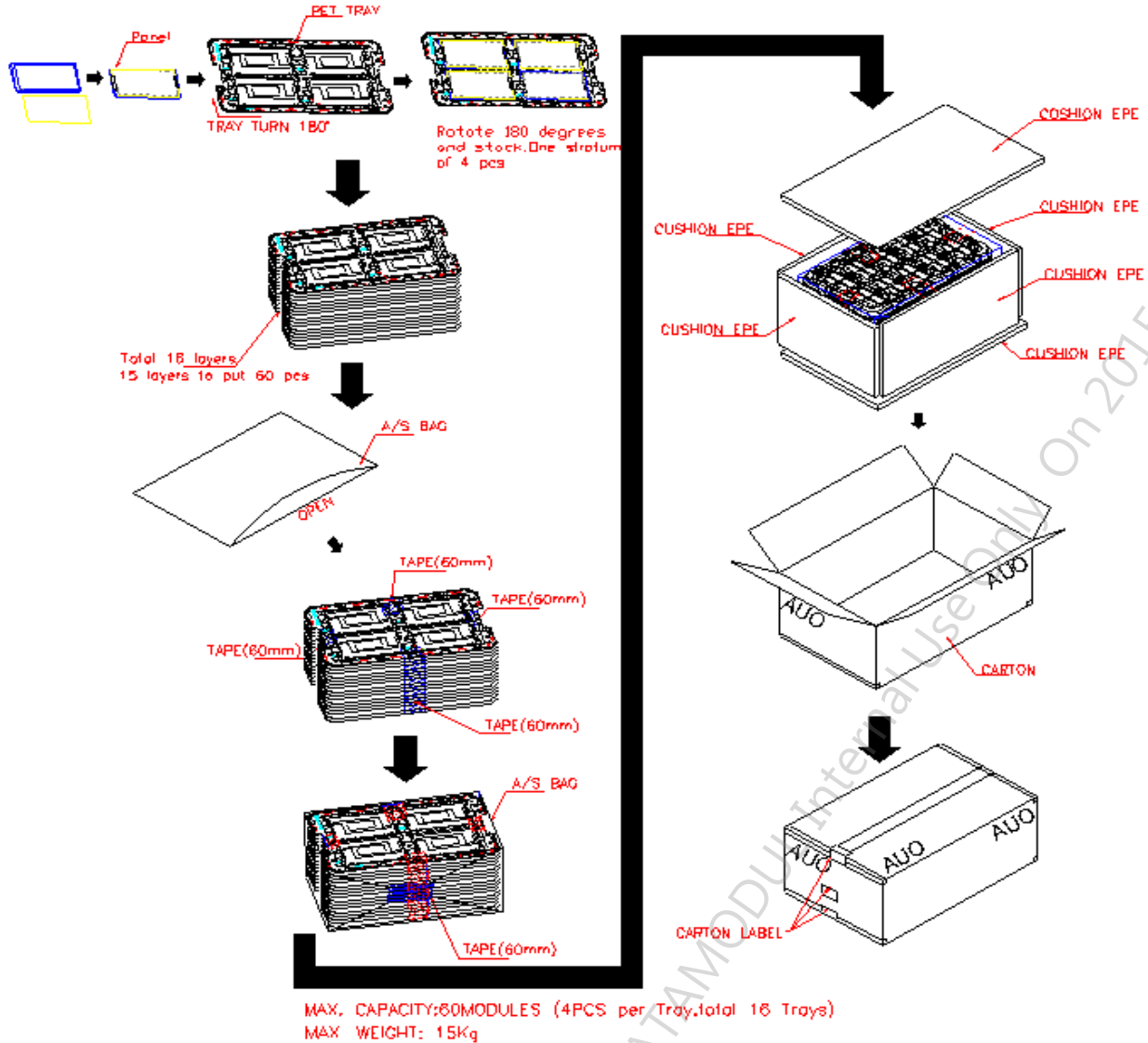

2. Module/Panel Label Information



G. Precautions

1. Do not twist or bend the module and prevent the unsuitable external force for display module during assembly.
2. Adopt measures for good heat radiation. Be sure to use the module with in the specified temperature.
3. Avoid dust or oil mist during assembly.
4. Follow the correct power sequence while operating. Do not apply the invalid signal, otherwise, it will cause improper shut down and damage the module.
5. Less EMI: it will be more safety and less noise.
6. Please operate module in suitable temperature. The response time & brightness will drift by different temperature.
7. Avoid to display the fixed pattern (exclude the white pattern) in a long period, otherwise, it will cause image sticking.
8. Be sure to turn off the power when connecting or disconnecting the circuit.
9. Polarizer scratches easily, please handle it carefully.
10. Display surface never likes dirt or stains.
11. A dewdrop may lead to destruction. Please wipe off any moisture before using module.
12. Sudden temperature changes cause condensation, and it will cause polarizer damaged.
13. High temperature and humidity may degrade performance. Please do not expose the module to the direct sunlight and so on.
14. Acetic acid or chlorine compounds are not friends with TFT display module.
15. Static electricity will damage the module, please do not touch the module without any grounded device.
16. Do not disassemble and reassemble the module by self.
17. Be careful do not touch the rear side directly.
18. No strong vibration or shock. It will cause module broken.
19. Storage the modules in suitable environment with regular packing.
20. Be careful of injury from a broken display module.
21. Please avoid the pressure adding to the surface (front or rear side) of modules, because it will cause the display non-uniformity or other function issue.
22. It was forbidden to bend the FPC upward to the panel surface.”