



- Preliminary Specification
- Final Specification

<b>Module</b>	<b>7.0 Inch Color TFT-LCD</b>
<b>Model Name</b>	<b>G070VFN01.100</b>

<table style="width: 100%; border-collapse: collapse;"> <tr> <td style="width: 50%; text-align: center;"><b>Customer</b></td> <td style="width: 50%; text-align: center;"><b>Date</b></td> </tr> <tr> <td style="border-top: 1px solid black; height: 40px;"></td> <td style="border-top: 1px solid black; height: 40px;"></td> </tr> <tr> <td style="text-align: center; padding-top: 20px;"><b>Checked &amp; Approved by</b></td> <td style="text-align: center; padding-top: 20px;"><b>Date</b></td> </tr> <tr> <td style="border-top: 1px solid black; height: 40px;"></td> <td style="border-top: 1px solid black; height: 40px;"></td> </tr> </table>	<b>Customer</b>	<b>Date</b>			<b>Checked &amp; Approved by</b>	<b>Date</b>			<table style="width: 100%; border-collapse: collapse;"> <tr> <td style="width: 50%; text-align: center;"><b>Approved by</b></td> <td style="width: 50%; text-align: center;"><b>Date</b></td> </tr> <tr> <td style="border-top: 1px solid black; text-align: center;">Grace Hung</td> <td style="border-top: 1px solid black; text-align: center;">2013/10/29</td> </tr> <tr> <td style="text-align: center; padding-top: 20px;"><b>Prepared by</b></td> <td style="text-align: center; padding-top: 20px;"><b>Date</b></td> </tr> <tr> <td style="border-top: 1px solid black; text-align: center;">Mask Tsai</td> <td style="border-top: 1px solid black; text-align: center;">2013/10/29</td> </tr> </table>	<b>Approved by</b>	<b>Date</b>	Grace Hung	2013/10/29	<b>Prepared by</b>	<b>Date</b>	Mask Tsai	2013/10/29
<b>Customer</b>	<b>Date</b>																
<b>Checked &amp; Approved by</b>	<b>Date</b>																
<b>Approved by</b>	<b>Date</b>																
Grace Hung	2013/10/29																
<b>Prepared by</b>	<b>Date</b>																
Mask Tsai	2013/10/29																
<p>Note: This Specification is subject to change without notice.</p>	<p>General Display Business Division / AU Optronics corporation</p>																

- APPROVAL FOR SPECIFICATIONS ONLY (Spec. Ver. 1.5 )
- APPROVAL FOR SPECIFICATIONS AND ES SAMPLE (Spec. Ver. 1.5 )
- APPROVAL FOR SPECIFICATIONS AND CS SAMPLE (Spec. Ver. 1.5 )
- CUSTOMER REMARK :

AUO Confidential For PROMATE Internal Use Only On 2014/01/10



## Contents

<b>1. Operating Precautions</b> .....	<b>4</b>
<b>2. General Description</b> .....	<b>5</b>
2.1 Features .....	5
2.2 Display Characteristics .....	5
2.3 Optical Characteristics.....	6
<b>3. Functional Block Diagram</b> .....	<b>9</b>
<b>4. Absolute Maximum Ratings</b> .....	<b>10</b>
4.1 Absolute Ratings of Driving Condition .....	10
4.2 Absolute Ratings of Environment .....	10
<b>5. Electrical Characteristics</b> .....	<b>11</b>
5.1 TFT-LCD Driving Condition.....	11
5.2 Backlight Unit Driving Condition .....	11
<b>6. Signal Characteristic</b> .....	<b>12</b>
6.1 Pixel Format Image.....	12
6.2 Scanning Direction .....	12
6.3 The Input Data Format.....	13
6.4 TFT- LCD Pin Assignment Description.....	14
6.5 Power on/off sequence.....	16
6.6 TFT- LCD Driving Timing.....	17
<b>7. Reliability Test Criteria</b> .....	<b>19</b>
<b>8. Mechanical Characteristics</b> .....	<b>20</b>
<b>9. Label and Packaging</b> .....	<b>21</b>
9.1 Shipping Label (on the rear side of TFT-LCD display).....	21
9.2 Packing form .....	22
9.3 Palletizing sequence.....	22
<b>10 Safety</b> .....	<b>23</b>
10.1 Standard.....	23
10.2 Capacitors.....	23
10.3 National Test Lab Requirement.....	23



## Record of Revision

Version	Revise Date	Page	Old description
0.0	2013/3/27	-	First draft of preliminary specification.
0.1	2013/4/8	5	Revise 2.2 Display Characteristics
		20	Add 8. Mechanical Characteristics
1.0	2013/08/19	5	Typical Power Consumption : 2688mW
		6	Color / Chromaticity Coordinates (CIE 1931) : TBD Contrast Ratio : TBD (min.)
		11	VDD Current/VDD Power : TBD
		16	Modify Power on sequence : Add internal power
		21	SN Lable: C070FW01 V0
		21	Packing information Max. capacity: 45 pieces TFT-LCD module per carton Max. weight: 13.0 kg per carton Outside dimension of carton: 600(L)mm* 353(W)mm* 210(H)mm Pallet : 1230(L)mm* 1110(W)mm* 135(H)mm
1.1	2013/8/27	21	Enlarge 9.1 Shipping Label (on the rear side of TFT-LCD display)
1.2	2013/8/28	10	Update 4.1 Absolute Ratings of Driving Condition
1.3	2013/9/9	14,15	Modify 6.4 TFT- LCD Pin Assignment Description
1.4	2013/10/17	21	Modify 9.1 Shipping Label (on the rear side of TFT-LCD display)
		All	Modify module name from G070VFN01.1 to G070VFN01.100
1.5	2013/10/29	21	Modify 9.1 Shipping Label (on the rear side of TFT-LCD display)

AUO Confidential For PROMATE Internal Use Only On 2014/01/10



## 1. Operating Precautions

- 1) Display area (Polarizer) of TFT-LCD Module is easily to be damaged, please be cautious and not to scratch it.
- 2) Be sure to power off your machine before connecting or disconnecting your signal cable to TFT-LCD Module.
- 3) Wipe off water drop on display area immediately. Long contact with water may cause discoloration or spots.
- 4) When the panel surface is soiled, wipe it with absorbent cotton or soft cloth.
- 5) Display area (Glass) of TFT-LCD Module may be broken or cracked if bump Module against hard object.
- 6) To avoid ESD (Electro Static Discharge) damage, be sure to ground yourself before handling TFT-LCD Module.
- 7) Do not open nor modify the TFT-LCD module assembly.
- 8) Do not press the reflector sheet at the back of the module to any direction.
- 9) In case if TFT-LCD module has to be put back into the packing container slot after it was taken out from the container, do not press the center of the LED Reflector edge. Instead, press at the far ends of the LED Reflector edge softly. Otherwise the TFT-LCD Module may be damaged.
- 10) When inserting or removing of your signal cable to TFT-LCD Module, be sure not to apply abnormal force (rotate, tilt...etc.) to the Connector of the TFT-LCD Module.
- 11) TFT-LCD Module is not allowed to be twisted & bent even force is added on module in a very short time. Please design your display product well to avoid external force applying to module by end-user directly.
- 12) Small amount of materials without flammability grade are used in the TFT-LCD module. The TFT-LCD module should be supplied by power complied with requirements of Limited Power Source (IEC60950 or UL1950), or be applied exemption.
- 13) Severe temperature condition may result in different luminance, response time.
- 14) Continuous operating TFT-LCD Module under high temperature environment may accelerate LED light bar exhaustion and reduce luminance dramatically.
- 15) The data on this specification sheet is applicable when TFT-LCD module is placed in landscape position.
- 16) Continuous displaying fixed pattern may induce image sticking. It's recommended to use screen saver or moving content periodically if fixed pattern is displayed on the screen.



## 2. General Description

This specification applies to the 7.0 inch color TFT LCD with AMVA (Advanced MVA) technology module G070VFN01.100. It composed of a TFT-LCD panel, driver ICs, PCB with power supply circuit and backlight unit.

The screen format is intended to support the WVGA (800(H) x 480(V)) screen and 16.2M (8-bits) or 262k colors (6-bits) by digital RGB interface.

### 2.1 Features

- 7.0 inch (15:9) display
- WVGA (800 × 480) resolution
- Digital parallel RGB 6/8bit interface
- San direction reversible
- High brightness
- High Contrast ratio
- Wide viewing angle with Advanced MVA technology
- RoHs compliance

### 2.2 Display Characteristics

The following items are G070VFN01.100 characteristics summary at 25 °C (Room Temperature).

Items		Unit	Specifications
Screen Diagonal		inch	7.0
Outline Dimension		mm	164.55(H) × 104.71(V) × 8(T)
Active Area Size		mm	152.4(H)×91.44(V)
Resolution		dots	800RGB(H)×480(V)
Pixel Pitch		mm	0.1905(H)×0.1905(V)
Pixel Arrangement		—	R.G.B. Vertical Stripe
Display Mode		—	AMVA, Normally Black
Color Depth		—	16.2M (8bit) / 262K (6bit) colors
Nominal Input Power	LCD	V	3.3
	Backlight	mA	120
Typical Power Consumption		mW	3216 (Typ.)
Typical Weight		g	143
Surface Treatment		—	Anti-Glare, Hardness 3H
Temperature Range	Operating	°C	-20 to +70
	Storage(Non-Operating)	°C	-30 to +80

### 2.3 Optical Characteristics

The optical characteristics are measured under stable conditions at 25°C (Room Temperature).

Item	Conditions	Min.	Typ.	Max.	Unit	Remark	
White Luminance	$\Theta_x = 0^\circ; \Theta_y = 0^\circ$	390	450	—	cd/m <sup>2</sup>	Note 1	
Contrast Ratio		800	1500	—		Note 1, 2	
Response Time	$\Theta_x = 0^\circ$ $\Theta_y = 0^\circ$	Rising (Tr)	—	10	15	ms	Note 1, 3
		Falling (Tf)	—	25	30		
		Tr + Tf	—	35	45		
Viewing Angle	Horizontal CR $\geq 10$	Right	75	80	—	degree	Note 1, 4
		Left	75	80	—		
	Vertical CR $\geq 10$	Top	75	80	—		
		Bottom	75	80	—		
Color / Chromaticity Coordinates (CIE 1931)	White x	0.263	0.313	0.363		Note 1	
	White y	0.259	0.309	0.359			
	Red x	0.536	0.586	0.636			
	Red y	0.275	0.325	0.375			
	Green x	0.265	0.315	0.365			
	Green y	0.536	0.586	0.636			
	Blue x	0.103	0.153	0.203			
Blue y	0.058	0.108	0.158				
Color Gamut		—	50	—	%	Note 1	
Uniformity	9 Points	80		—	%	Note 1, 5	

**Note 1 : Measurement method and condition**

<b>Equipment</b>	Pattern Generator, Power Supply, Digital Voltmeter, Topcon luminance meter BM-7
<b>Test Point</b>	Aperture = 1° with 50cm viewing distance at center of active area
<b>Condition</b>	1. Performed in the dark and windless room (Ambient light < 1 lux) 2. Measured after 10 minutes operation under backlight current I <sub>LED</sub> = 120mA.

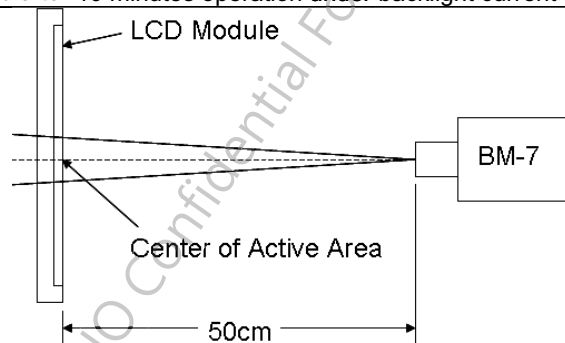

Fig. 2-1

**Note 2 :** Definition of contrast ratio (CR)

$$\text{Contrast ratio (CR)} = \frac{\text{Brightness @ "White" state}}{\text{Brightness @ "Black" state}}$$

**Note 3 :** Definition of response time

The output signals of photo detector are measured when the input signals are changed from "White" to "Black" (falling time) and from "Black" to "White" (rising time), respectively. The response time interval definition is between 10% and 90% of amplitude. Please refer to the figure as below.

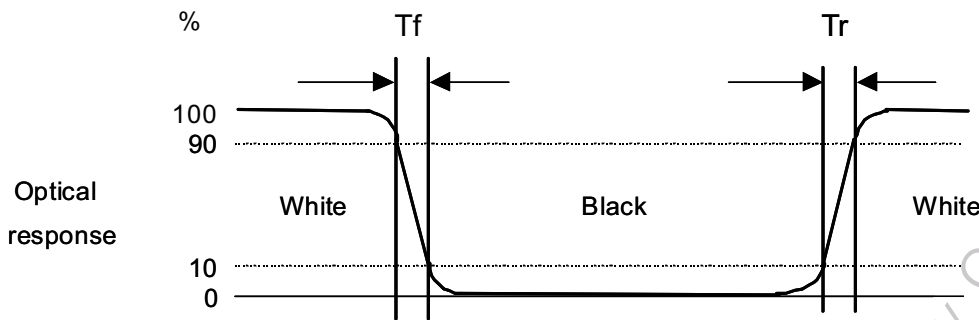

Fig. 2-2

**Note 4 :** Definition of viewing angle

Viewing angle is the measurement of contrast ratio  $\geq 10$ , at the screen center, over 180° horizontal and 180° vertical range. The 180° horizontal ( $\theta_L$ ,  $\theta_R$ ) and 180° vertical ( $\phi_H$ ,  $\phi_L$ ) range are illustrated as following figure.

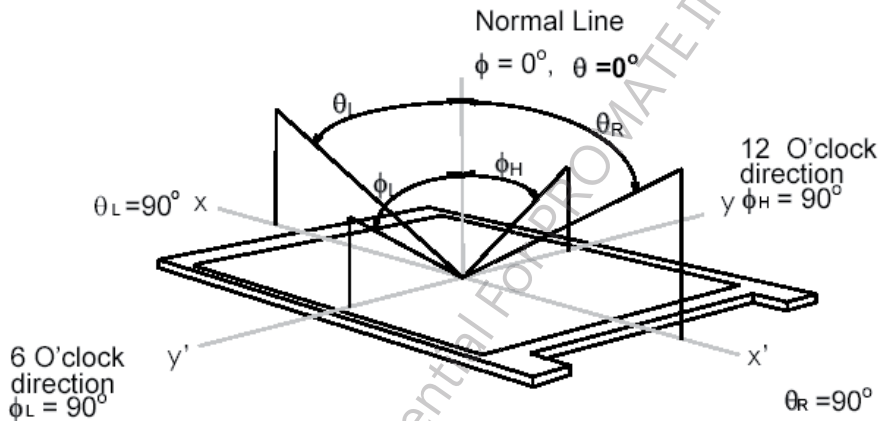

Fig. 2-3

**Note 5 :** Definition of 9 points position on Active Area

The luminance uniformity of 9 points is defined by dividing the maximum luminance value by the minimum luminance value at full white condition.

$$\text{Luminance Uniformity (\%)} = \frac{\text{Maximum Brightness of nine points}}{\text{Minimum Brightness of nine points}}$$

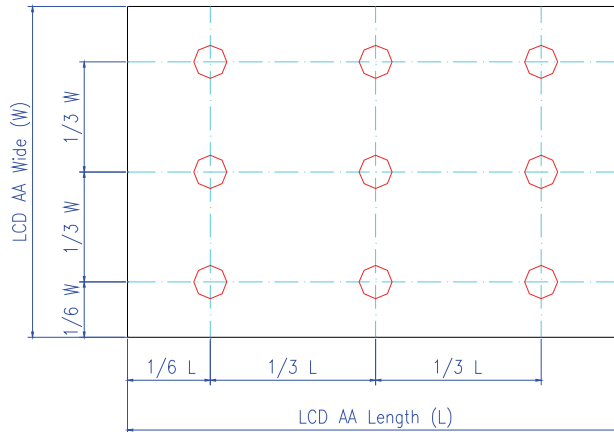

Fig.2-4

AUO Confidential For PROMATE Internal Use Only On 2014/01/10



### 3. Functional Block Diagram

The following diagram shows the functional block of the G070VVN01.100 color TFT/LCD module.

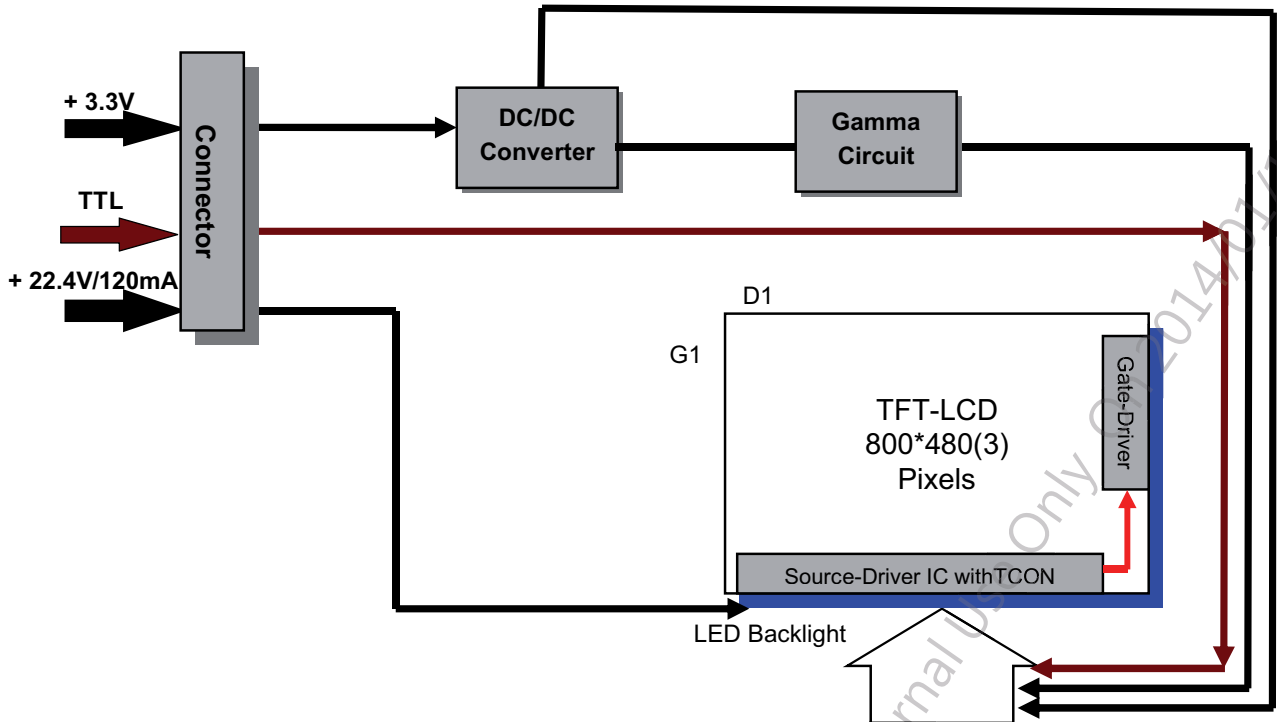

Fig. 3-1

AUO Confidential For PROMATE Internal Use Only 2014/01/10



## 4. Absolute Maximum Ratings

### 4.1 Absolute Ratings of Driving Condition

Following characteristics are measured under stable condition at 25°C (Room Temperature).

Parameter	Symbol	Min	Max	Unit	Remark
Logic/LCD Drive Voltage	VDD	-0.3	4.5	V	
LCD Input Signal Voltage	VIN	-0.3	4.5	V	
LED BLU Drive Current	V <sub>LED</sub>	—	180	mA	

### 4.2 Absolute Ratings of Environment

Parameter	Symbol	Min	Max	Unit	Remark
Operating Temperature	TOP	-20	70	°C	Note 1, 2
Operation Humidity	HOP	5	90	%RH	Note 1, 2
Storage Temperature	TST	-30	80	°C	Note 1
Storage Humidity	HST	5	90	%RH	Note 1

**Note 1** : Maximum Wet-Bulb should be 39°C and no condensation.

**Note 2** : Only operation is guaranteed. Optical performance should be evaluated at 25°C only.

## 5. Electrical Characteristics

### 5.1 TFT-LCD Driving Condition

Following characteristics are measured under stable condition at 25°C (Room Temperature).

Parameter	Symbol	Min	Typ	Max	Units	Remark
Analog/LCD Drive Voltage	VDD	3.0	3.3	3.6	V	
VDD Current	IVDD	—	160	197	mA	Note 1, 2
VDD Power	PVDD	—	528	650	mW	

**Note 1 :** Display all White pattern under VDD = 3.3V, frame frequency = 60Hz.

**Note 2 :** Input signals shall be low or Hi-Z state when VDDIO is off.

### 5.2 Backlight Unit Driving Condition

Following characteristics are measured under stable condition at 25°C (Room Temperature).

Parameter	Symbol	Min	Typ	Max	Units	Remark
Input Voltage	V <sub>LED</sub>	—	22.4	25.2	V	
Input Current	I <sub>LED</sub>	—	120	—	mA	
Power Consumption	P <sub>LED</sub>	—	2.688	3.024	W	
LED Lifetime	LED <sub>L</sub>	30000	—	—	Hrs	

**Note 1 :** Backlight unit composed of 14 LEDs. (2 stings, 7 pcs for each string)

**Note 2 :** The definition of LED lifetime is when B/L continues to operate under typical driving current, duty 100% and ambient temperature = 25°C until the brightness becomes  $\leq 50\%$  of its original value.

**Note 3 :** Operating LED under high temperature, humidity environment and driving current will reduce lifetime and lead to color shift.

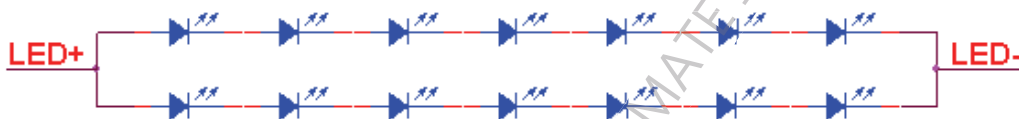

Fig. 5-1

## 6. Signal Characteristic

### 6.1 Pixel Format Image

Following figure shows the relationship between input signal and LCD pixel format.

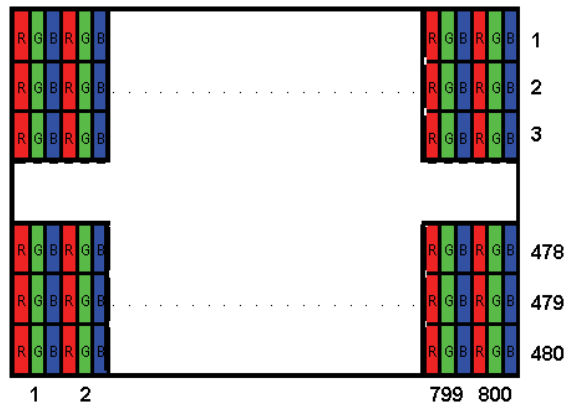
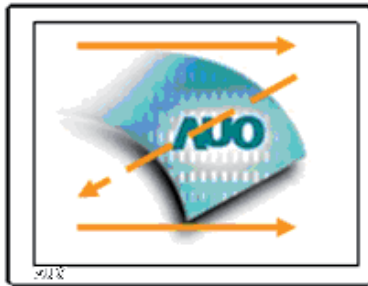

Fig. 6-1

### 6.2 Scanning Direction

The following figures show the image seen from the front view. The arrow indicates the direction of scan.



SHLR = High; UPDN = Low

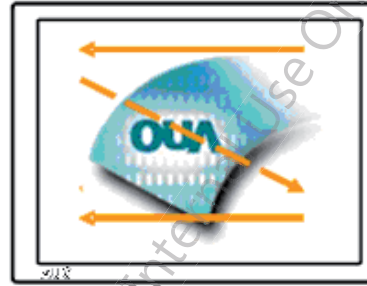

SHLR = Low; UPDN = Low

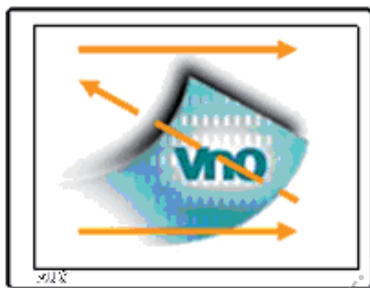

SHLR = High; UPDN = High

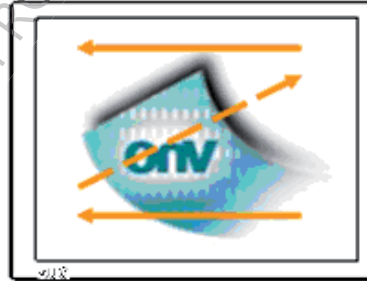

SHLR = Low; UPDN = High

Fig. 6-2

Note 1: TFT-LCD interface signal description is shown in section



### 6.3 The Input Data Format

This product displays 16.2M colors in terms of the 256 grey levels on RGB respectively.

Display colors		Data signal (0 : Low level, 1: High level)																							
		R7	R6	R5	R4	R3	R2	R1	R0	G7	G6	G5	G4	G3	G2	G1	G0	B7	B6	B5	B4	B3	B2	B1	B0
Basic colors	Black	0	0	0	0	0	0	0	0	0	0	0	0	0	0	0	0	0	0	0	0	0	0	0	0
	Blue	0	0	0	0	0	0	0	0	0	0	0	0	0	0	0	0	1	1	1	1	1	1	1	1
	Red	1	1	1	1	1	1	1	1	0	0	0	0	0	0	0	0	0	0	0	0	0	0	0	0
	Magenta	1	1	1	1	1	1	1	1	0	0	0	0	0	0	0	0	1	1	1	1	1	1	1	1
	Green	0	0	0	0	0	0	0	0	1	1	1	1	1	1	1	1	0	0	0	0	0	0	0	0
	Cyan	0	0	0	0	0	0	0	0	1	1	1	1	1	1	1	1	1	1	1	1	1	1	1	1
	Yellow	1	1	1	1	1	1	1	1	1	1	1	1	1	1	1	1	0	0	0	0	0	0	0	0
	White	1	1	1	1	1	1	1	1	1	1	1	1	1	1	1	1	1	1	1	1	1	1	1	1
Red grayscale	Black	0	0	0	0	0	0	0	0	0	0	0	0	0	0	0	0	0	0	0	0	0	0	0	0
	Dark	0	0	0	0	0	0	0	1	0	0	0	0	0	0	0	0	0	0	0	0	0	0	0	0
	↕																								
	bright	1	1	1	1	1	1	0	1	0	0	0	0	0	0	0	0	0	0	0	0	0	0	0	0
	Red	1	1	1	1	1	1	1	0	0	0	0	0	0	0	0	0	0	0	0	0	0	0	0	0
Green grayscale	Black	0	0	0	0	0	0	0	0	0	0	0	0	0	0	0	0	0	0	0	0	0	0	0	0
	Dark	0	0	0	0	0	0	0	0	0	0	0	0	0	0	0	1	0	0	0	0	0	0	0	0
	↕																								
	bright	0	0	0	0	0	0	0	0	1	1	1	1	1	1	0	1	0	0	0	0	0	0	0	0
	Green	0	0	0	0	0	0	0	0	1	1	1	1	1	1	1	1	0	0	0	0	0	0	0	0
Blue grayscale	Black	0	0	0	0	0	0	0	0	0	0	0	0	0	0	0	0	0	0	0	0	0	0	0	0
	Dark	0	0	0	0	0	0	0	0	0	0	0	0	0	0	0	0	0	0	0	0	0	0	0	1
	↕																								
	bright	0	0	0	0	0	0	0	0	0	0	0	0	0	0	0	0	1	1	1	1	1	1	0	1
	Blue	0	0	0	0	0	0	0	0	0	0	0	0	0	0	0	0	1	1	1	1	1	1	1	0

AUO Confidential For PROMATE Internal Use Only On 2014/01/10



### 6.4 TFT- LCD Pin Assignment Description

Recommended connector: FA5B050HP1

Pin no	Symbol	I/O	Description	Remark
1	VDD	P	Power supply, 3.3V(typical)	
2	VDD	P	Power supply, 3.3V(typical)	
3	NC	-	No connection. Please leave it open or connect to ground	
4	GND	G	Power ground	
5	RSTB	I	Global reset. Active Low to enter Reset State. (Normally pull high) Suggest to connecting with an RC reset circuit for stability. Normally pull high.	Note2
6	STBYB	I	Standby mode. Normally pulled high. STBYB = "H", normal operation STBYB = "L", timing controller, source driver will turn off, all output are high-Z.	
7	GND	I	Power ground	
8	UPDN	I	Gate up or down scan control. Normally pulled low. UPDN = "H", up shift: G480 → ... → G2 → G1. UPDN = "L", down shift: G1 → G2 → ... → G480.	
9	SHLR	I	Source right or left control. Normally pulled high. SHLR = "H", Shift right: first data =S1→S2→...→ S800 = last data. SHLR = "L", Shift left: last data =S1←S2←...← S800 = first data.	
10	DITHB	I	Dithering function enable control. Normally pulled high. DITHB = "H", Disable internal dithering function. DITHB = "L", Enable internal dithering function.	
11	MODE	I	DE/SYNC mode select. Normally pulled high. MODE = "H" : DE mode. MODE = "L" : HSD/VSD mode.	
12	GND	G	Power ground	
13	R0	I	Red data (LSB)	
14	R1	I	Red data	
15	R2	I	Red data	
16	R3	I	Red data	
17	R4	I	Red data	
18	R5	I	Red data	
19	R6	I	Red data	
20	R7	I	Red data (MSB)	
21	GND	G	Power ground	
22	G0	I	Green data (LSB)	
23	G1	I	Green data	
24	G2	I	Green data	
25	G3	I	Green data	
26	G4	I	Green data	
27	G5	I	Green data	
28	G6	I	Green data	
29	G7	I	Green data (MSB)	

30	GND	G	Power ground	
31	B0	I	Blue data (LSB)	
32	B1	I	Blue data	
33	B2	I	Blue data	
34	B3	I	Blue data	
35	B4	I	Blue data	
36	B5	I	Blue data	
37	B6	I	Blue data	
38	B7	I	Blue data (MSB)	
39	GND	G	Power ground	
40	CLKIN	I	Pixel clock · rising latch	
41	GND	G	Power ground	
42	DEN	I	Data input enable. Active high to enable the data input bus under "DE mode". Normally pulled Low.	
43	GND	G	Power ground	
44	HSD	I	Horizontal sync input. Negative polarity.	
45	GND	G	Power ground	
46	VSD	I	Vertical sync input. Negative polarity.	
47	GND	G	Power ground	
48	NC	-	No connection. Please leave it open or connect to ground	
49	LED+	P	Power supply for LED	
50	LED-	P	Power supply for LED	

**Note :** I: Digital signal input pin; P: Power pin; G: Ground pin;

**Note2 :** Global reset normally pulled high. Suggest to connecting with an RC (R=10K ohm, C=1uF) reset circuit for stability.

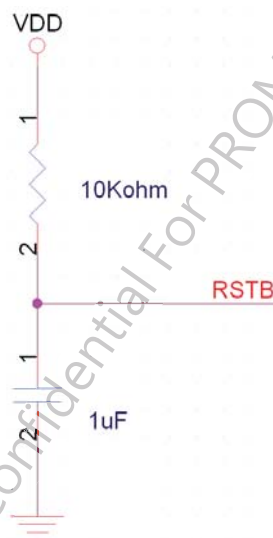

Fig. 6-3 Active Low

### 6.5 Power on/off sequence

The LCD adopts high voltage driver IC, so it could be permanently damaged under a wrong power on/off sequence. The suggested LCD power sequence is below:

**Power on sequence:**

**VDD → RSTB → STBYB → Digital input (Data/DCLK/DE) → BLKEN**

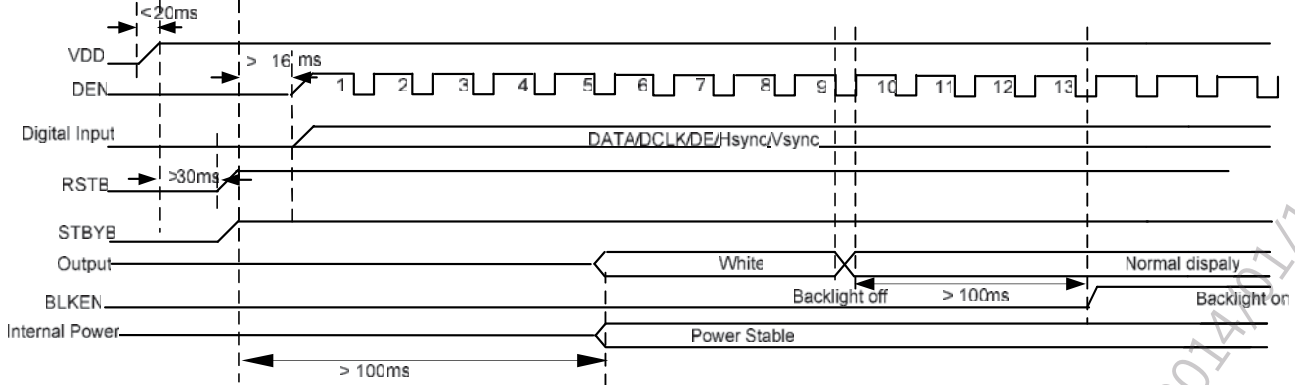

Fig. 6-4

**Power Off sequence :**

**STBYB → BLKEN → Digital input (Data/DCLK/DE)&Power**

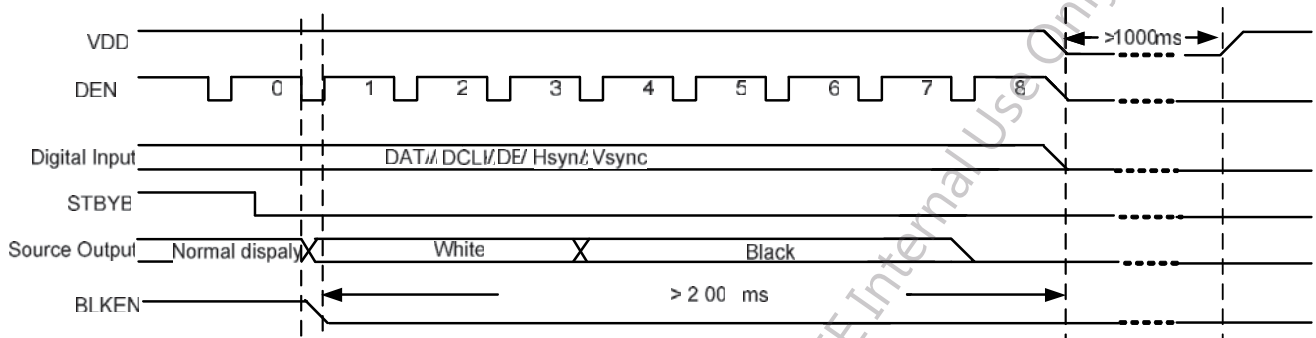

Fig. 6-5



## 6.6 TFT- LCD Driving Timing

### 6.6.1 Digital Signal Timing Characteristic

Item	Symbol	Min	Typ	Max	Unit	Remark
Clock frequency	dclk	-	33.3	45	MHZ	
DCLK cycle time	Tdclk	22	30	-	ns	
DCLK pulse duty	Tcwh	40	50	60	%	
Vertical display area	Tvd	480	480	480	H	
Vertical period area	Tv	517	525	712	H	
Vertical blanking area	Tvb	42	45	232	H	
Vertical pulse width	Tvw	1	1	3	H	Tvw+Tve=32H is fixed
Vertical back porch	Tve	31	31	29	H	
Vertical front porch	Tvf	5	13	200	H	
Horizontal display area	Thd	800	800	800	dclk	
Horizontal period area	Th	908	928	1088	dclk	
Horizontal blanking area	Thb	108	128	288	dclk	
Horizontal pulse width	Thw	1	48	87	dclk	Thw+The=88dclk is fixed
Horizontal back porch	The	87	40	1	dclk	
Horizontal front porch	Thf	20	40	200	dclk	
Data setup time	Tds	8	-	-	ns	
Data hold time	Tdh	8	-	-	ns	

**Note :** Recommended frame rate is 60 Hz.

### 6.6.2 Digital Signal Timing Diagram

#### a. Clock and Data Timing of Input :

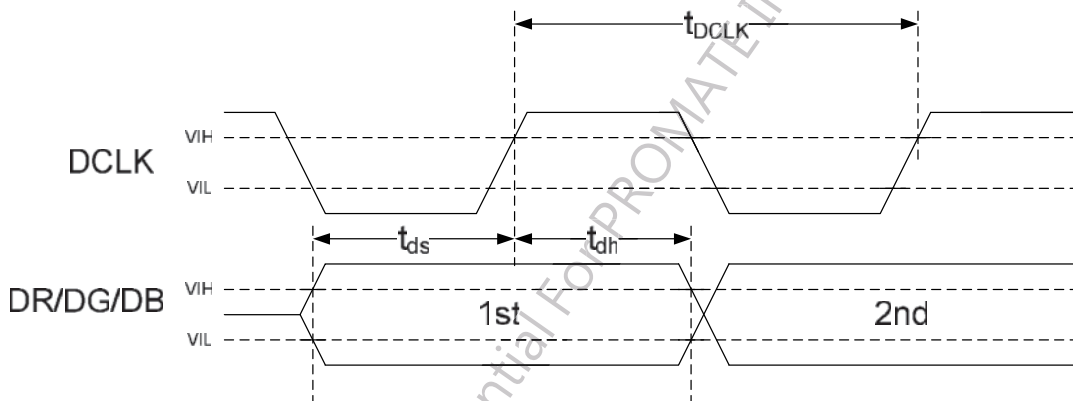

Fig. 6-6

**b. Vertical Timing of Input (DE Mode)**

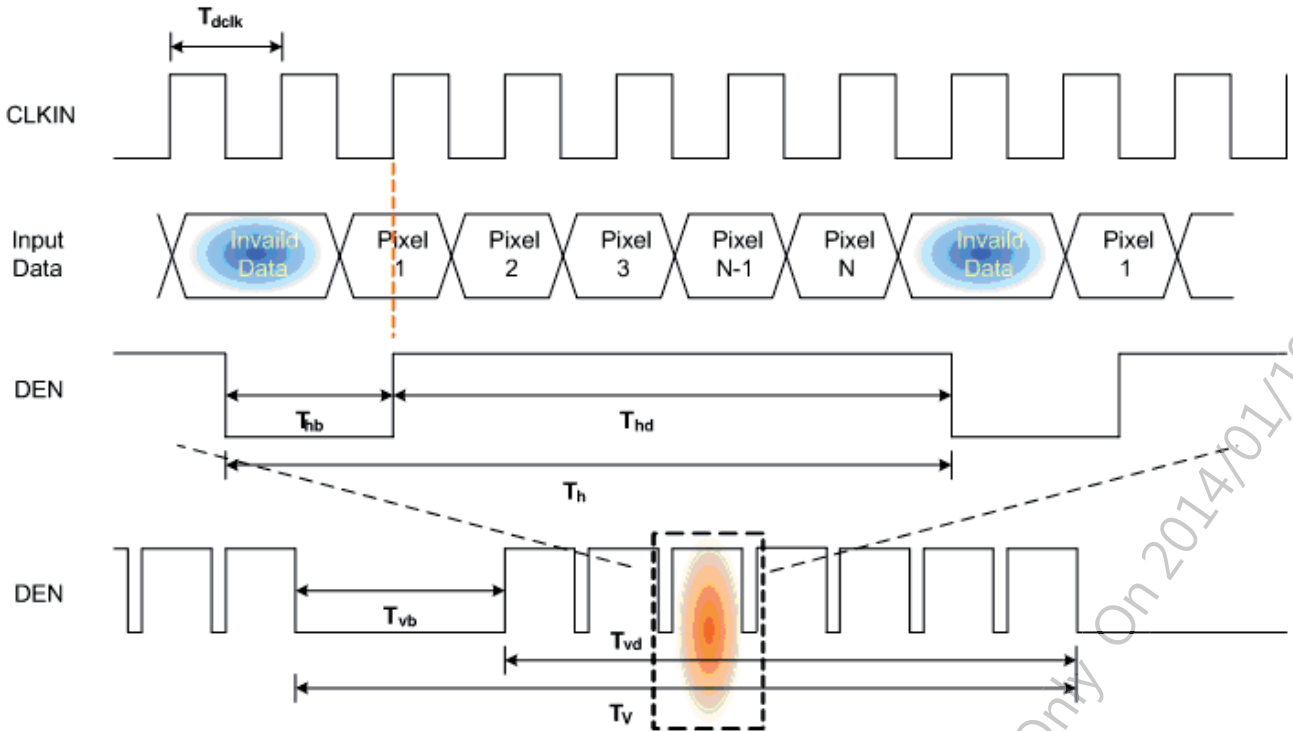

Fig. 6-7

**c. Vertical Timing of Input (HV Mode)**

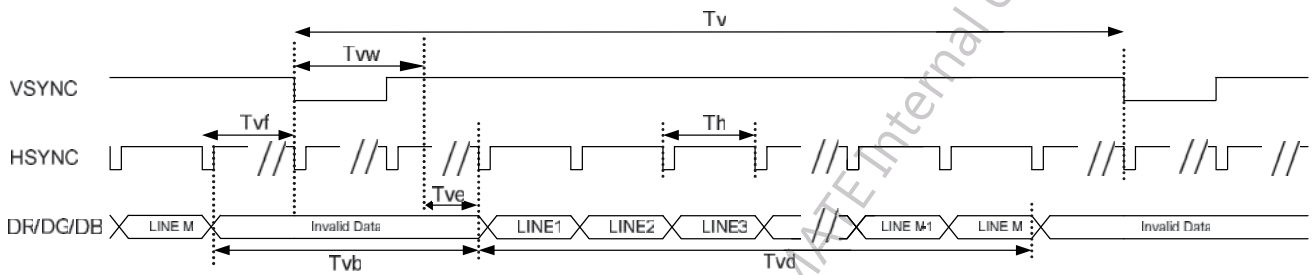

Fig. 6-8

**d. Horizontal Timing of Input (HV Mode)**

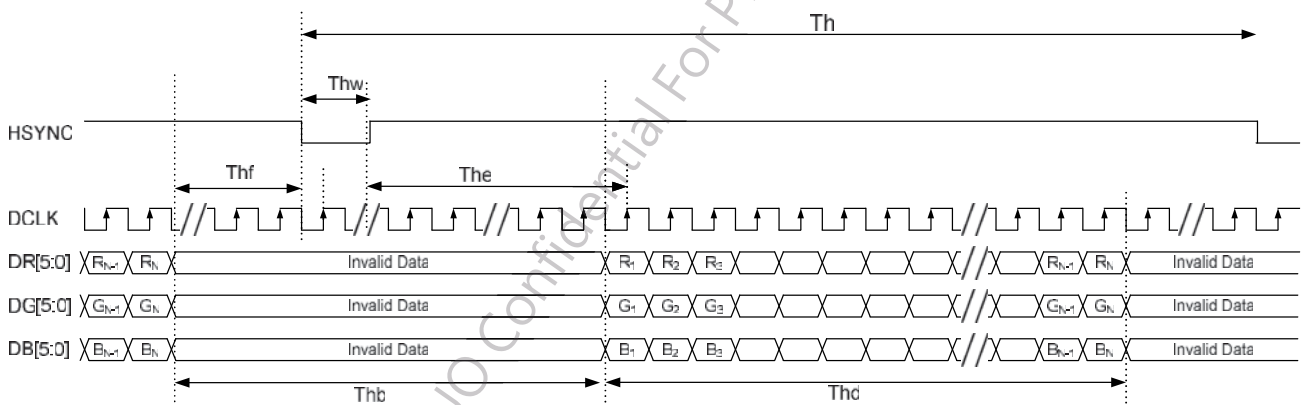

Fig. 6-9



## 7. Reliability Test Criteria

Test Items	Required Condition			Remark
High Temperature Operation	70°C	240Hours	Operation	
Low Temperature Operation	-20°C	240Hours	Operation	
High Temperature Storage	80°C	240Hours	Non-operation	
Low Temperature Storage	-30°C	240Hours	Non-operation	
High temperature and high humidity	60°C, 90% RH	240Hours	Operation	
Thermal Shock	-30°C/60 min ,80°C/60 min ,50cycles		Non-operation	
Mechanical shock	50G, 20ms, Half-sine wave, Once for each direction. (±x, ±y, ±z)		Non-operation	
Vibration	1.5G, 10~200~10Hz, Sine wave, 30min/axis (X, Y, Z)		Non-operation	
On/off	On/10 sec, off/10 sec, 30,000 cycles			
Electrostatic discharge	Contact = ± 8 kV, class B (R=330,C=150pF) Air = ± 15 kV, class B (R=330,C=150pF) 1sec, 8 points, 25times/point			

- Note 1 :** Each test is done by new TFT-LCD module. Don't use the same TFT-LCD module repeatedly for reliability test.
- Note 2 :** The reliability test is performed only to examine the TFT-LCD module capability.
- Note 3 :** In the standard condition, there is not display function NG issue occurred. All cosmetic specifications are judged before the reliability stress. To inspect TFT-LCD module after reliability test, please store it at room temperature and room humidity for 24 hours at least in advance.
- Note 4 :** There should be no condensation on the surface of module during test.
- Note 5 :** Short time operation between -20°C~-30°C doesn't provide full performance but a correct image on the LCD. The LCD is guaranteed to suffer no permanent damage.
- Note 6 :** The fixture of Vibration and Shock test should be hard and rigid enough in order to protect from module twisting or bending issue.
- Note 7 :** ESD criteria is as below :

Class A	Normal operation. No degradation. No failures
Class B	Some performance degradation allowed. No data lost. Self-recoverable. No hardware failures.
Class C	Temporary performance degradation. Recovery by operator is acceptable. No hardware failures.
Class D	Hardware failures.



# 8. Mechanical Characteristics

G070VVN01.100

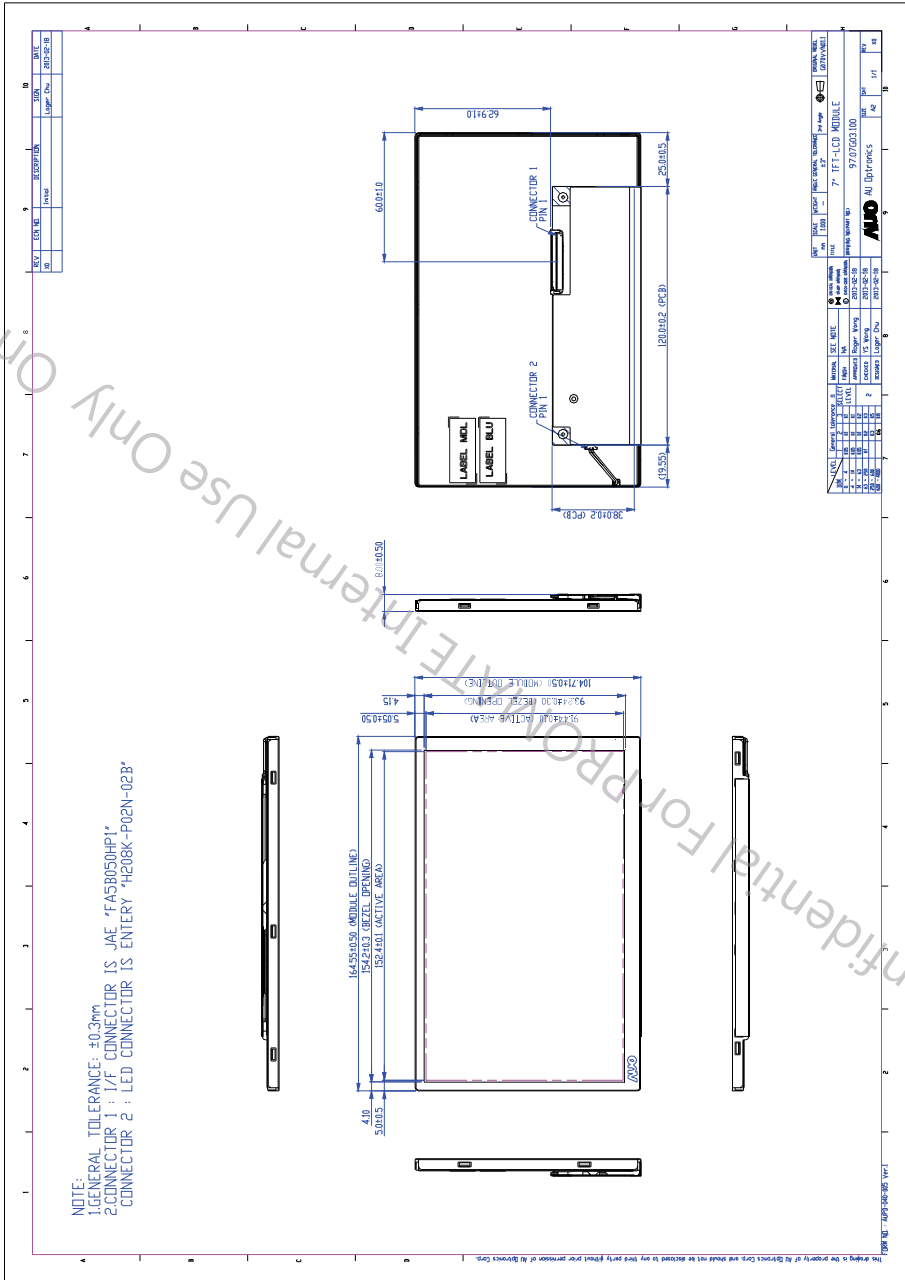

G070VVN01.100 Ver. 1.5  
20/23

## 9. Label and Packaging

### 9.1 Shipping Label (on the rear side of TFT-LCD display)

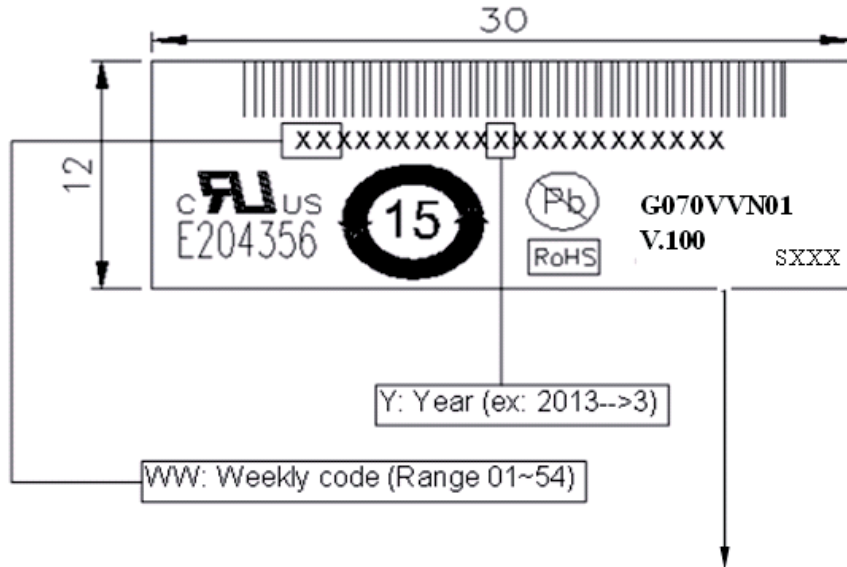

1	2	3	4	5	6	7	8	9	10	11
G	0	7	0	V	V	N	0	1	V.	100
<b>Application</b> A: AV C: Car G: GD	<b>Size</b> (7.0 inch)			<b>Resolution</b> (WVGA, 800×480)	<b>Technology</b> (MVA)	<b>Product Feature</b> (Normal)	<b>Serial No.</b>		NA	<b>Version &amp;Part Number</b>

Fig. 9-1 SN Label



## 9.2 Packing form

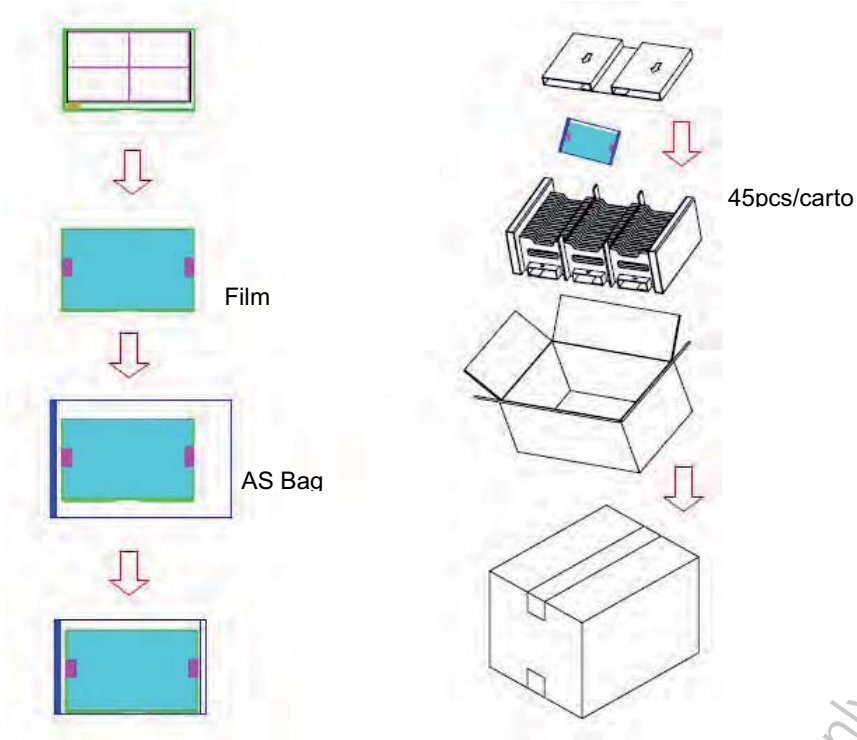

Fig. 9-2

Max capacity : 45 TFT-LCD module per carton

Max weight: 10.0 kg per carton

Outside dimension of carton: 608mm(L)\* 361mm(W)\*226mm(H)

Pallet size: 1230 mm \* 1110 mm \* 135mm

## 9.3 Palletizing sequence

	pcs / box	box / layer	layer / pallet	pcs / pallet
Shipping by air	45	6	5	1350
Shipping by sea	45	6	5	1350



## 10 Safety

### 10.1 Standard

The TFT-LCD Module will be satisfied all requirements for compliance with UL 60950 (U.S.A. Information Technology Equipment).

#### 10.1.1 Keen Edge Requirements

There will be no keen edges or corners on the display assembly that could cause injury.

#### 10.1.2 Flammability

All components including electrical components that do not meet the flammability grade UL94-V1 in the TFT-LCD Module.

The critical components of safety will be compliance with UL 60950 requirement exception approval process.

The printed circuit board will be made from material rated 94-V1 or better. The actual UL flammability rating will be printed on the printed circuit board.

### 10.2 Capacitors

If any polarized capacitors are used in the TFT-LCD module, provisions will be made to keep them from being inserted backwards.

### 10.3 National Test Lab Requirement

The TFT-LCD Module will satisfy all requirements for compliance to UL 60950 (U.S.A. Information Technology Equipment).

AUO Confidential For PROMATE Internal Use Only On 2014/01/10