





## Contents

<b>1. Operating Precautions</b> .....	<b>4</b>
<b>2. General Description</b> .....	<b>5</b>
2.1 Display Characteristics.....	5
2.2 Optical Characteristics .....	6
<b>3. Functional Block Diagram</b> .....	<b>9</b>
<b>4. Absolute Maximum Ratings</b> .....	<b>10</b>
4.1 Absolute Ratings of TFT LCD Module .....	10
4.2 Absolute Ratings of Environment .....	10
<b>5. Electrical Characteristics</b> .....	<b>11</b>
5.1 TFT LCD Module .....	11
5.2 Backlight Unit.....	12
<b>6. Signal Characteristic</b> .....	<b>13</b>
6.1 Pixel Format Image .....	13
6.2 Signal Description .....	14
6.3 Interface Timing .....	16
6.4 Power ON/OFF Sequence .....	18
<b>7. Connector &amp; Pin Assignment</b> .....	<b>19</b>
7.1 TFT LCD Module: Connector information.....	19
<b>8. Reliability Test Criteria</b> .....	<b>20</b>
<b>9. Mechanical Characteristics</b> .....	<b>21</b>
9.1 LCM Outline Dimension (Front View) .....	21
9.2 LCM Outline Dimension (Rear View).....	22
<b>10. Label and Packaging</b> .....	<b>23</b>
10.1 Shipping Label (on the rear side of TFT-LCD display) .....	23
10.2 Carton Package .....	23





## 1. Operating Precautions

- 1) Since front polarizer is easily damaged, please be cautious and not to scratch it.
- 2) Be sure to turn off power supply when inserting or disconnecting from input connector.
- 3) Wipe off water drop immediately. Long contact with water may cause discoloration or spots.
- 4) When the panel surface is soiled, wipe it with absorbent cotton or soft cloth.
- 5) Since the panel is made of glass, it may be broken or cracked if dropped or bumped on hard surface.
- 6) To avoid ESD (Electro Static Discharge) damage, be sure to ground yourself before handling TFT-LCD Module.
- 7) Do not open nor modify the module assembly.
- 8) Do not press the reflector sheet at the back of the module to any direction.
- 9) In case if a module has to be put back into the packing container slot after it was taken out from the container, do not press the center of the LED light bar edge. Instead, press at the far ends of the LED light bar edge softly. Otherwise the TFT Module may be damaged.
- 10) At the insertion or removal of the Signal Interface Connector, be sure not to rotate nor tilt the Interface Connector of the TFT Module.
- 11) TFT-LCD Module is not allowed to be twisted & bent even force is added on module in a very short time. Please design your display product well to avoid external force applying to module by end-user directly.
- 12) Small amount of materials having no flammability grade is used in the LCD module. The LCD module should be supplied by power complied with requirements of Limited Power Source (IEC60950 or UL1950), or be applied exemption.
- 13) Severe temperature condition may result in different luminance, response time and lamp ignition voltage.
- 14) Continuous operating TFT-LCD display under low temperature environment may accelerate lamp exhaustion and reduce luminance dramatically.
- 15) The data on this specification sheet is applicable when LCD module is placed in landscape position.
- 16) Continuous displaying fixed pattern may induce image sticking. It's recommended to use screen saver or shuffle content periodically if fixed pattern is displayed on the screen.

## 2. General Description

This specification applies to the Color Active Matrix Liquid Crystal Display G090VTN02.0 composed of a TFT-LCD display, a driver and power supply circuit, and a LED backlight system. The screen format is intended to support WVGA (800(H) x 480(V)) screen and 16.7M (6bit + Hi-FRC).

G090VTN02.0 is a RoHS product.

### 2.1 Display Characteristics

The following items are characteristics summary on the table under 25 °C condition:

Items	Unit	Specifications
Screen Diagonal	[inch]	9
Active Area	[mm]	198.000(H) x 111.696(V)
Pixels H x V		800x3(RGB) x 480
Pixel Pitch	[mm]	0.0825x3 (H) x 0.2327 (V)
Pixel Arrangement		R.G.B. Vertical Stripe
Display Mode		TN, Normally White
Nominal Input Voltage VDD	[Volt]	3.3 (typ.)
Typical Power Consumption	[Watt]	2.8
Weight	[Grams]	255 (typ.)
Physical Size	[mm]	211.1(H)x 128.4(V) x 6.6(D) (typ.)
Electrical Interface		TTL
Surface Treatment		Anti-glare, Hardness 3H
Support Color		16.7M (6bit+Hi-FRC)
Temperature Range Operating Storage (Non-Operating)	[°C] [°C]	-20 to +75 -30 to +80
RoHS Compliance		RoHS Compliance

## 2.2 Optical Characteristics

The optical characteristics are measured under stable conditions at 25 °C (Room Temperature):

Item	Unit	Conditions	Min.	Typ.	Max.	Note
White Luminance	[cd/m <sup>2</sup> ]	Center point	250	300	-	A, B, F
Uniformity	%	5 points	70	-	-	A, B, F
Contrast Ratio			400	500	-	A, B, D
Response Time	[msec]	Rising	-	10	14	A, B, E
	[msec]	Falling	-	15	21	
	[msec]	Rising + Falling	-	25	35	
Viewing Angle	[degree]	Horizontal (Right)	60	70	-	A, B, C
	[degree]	CR = 10 (Left)	60	70	-	
	[degree]	Vertical (Upper)	40	50	-	
Color / Chromaticity Coordinates (CIE 1931)	[degree]	CR = 10 (Lower)	60	70	-	A, B
		Red x	0.554	0.584	0.614	
		Red y	0.328	0.358	0.388	
		Green x	0.302	0.332	0.362	
		Green y	0.535	0.565	0.595	
		Blue x	0.125	0.155	0.185	
		Blue y	0.063	0.093	0.123	
	White x	0.263	0.313	0.363		
	White y	0.279	0.329	0.379		

Note: A. Measurement Setup:

The LCD module should be stabilized at given temperature for 15 minutes to avoid abrupt temperature change during measuring. In order to stabilize the luminance, the measurement should be executed after lighting backlight for 15 minutes in a windless room.

B. The LED input parameter setting as:

V\_LED: 12V (±0.1V) ; I\_LED: 60mA

PWM\_LED: Duty 100 %

## C. Definition of Viewing Angle

### Definition of Viewing Angle

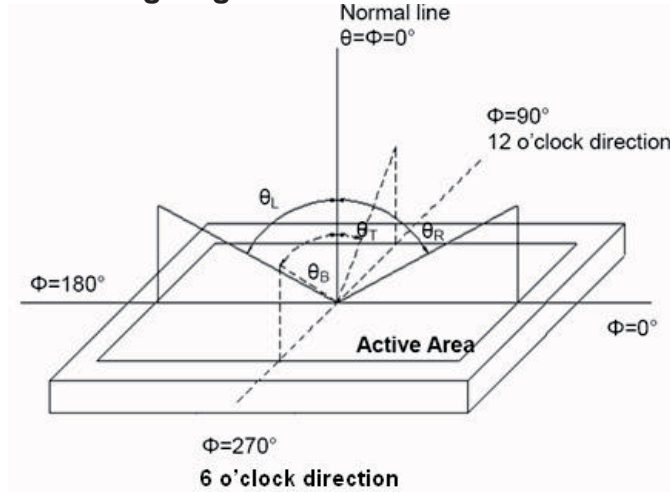

## D. Definition Of Contrast Ratio (CR)

The contrast ratio can be calculated by the following expression

$$\text{Contrast Ratio (CR)} = L_{63} / L_0$$

L63: Luminance of gray level 63, L0: Luminance of gray level 0

## E. Definition Of Response Time ( $T_R$ , $T_F$ )

**Figure 5 Definition of Response Time**

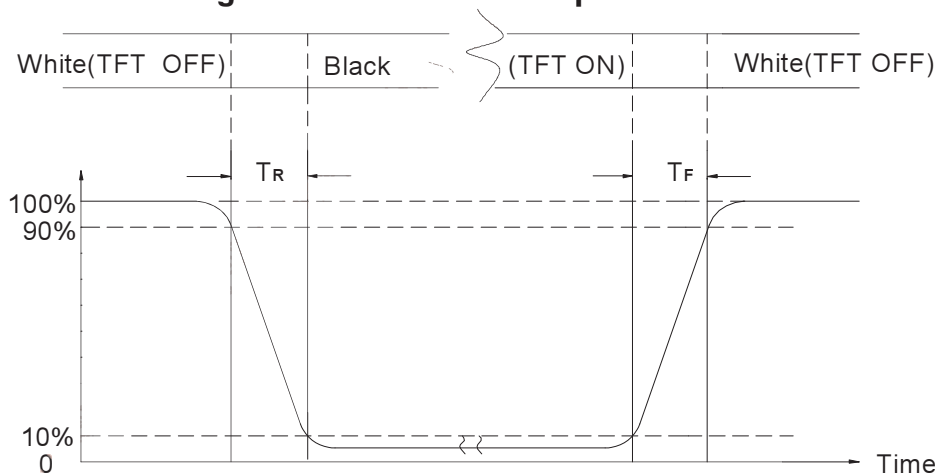

## F. Definition Of Brightness Luminance

$$\text{Luminance Uniformity} = \frac{(\text{MinLuminance of 9 points})}{(\text{MaxLuminance of 9 points})} \times 100\%$$

### Measurement Locations

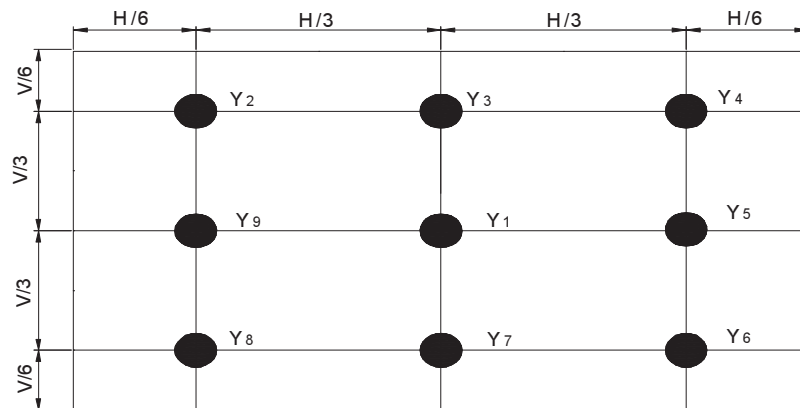



## 3. Functional Block Diagram

The following diagram shows the functional block of the 9 inch color TFT/LCD module:

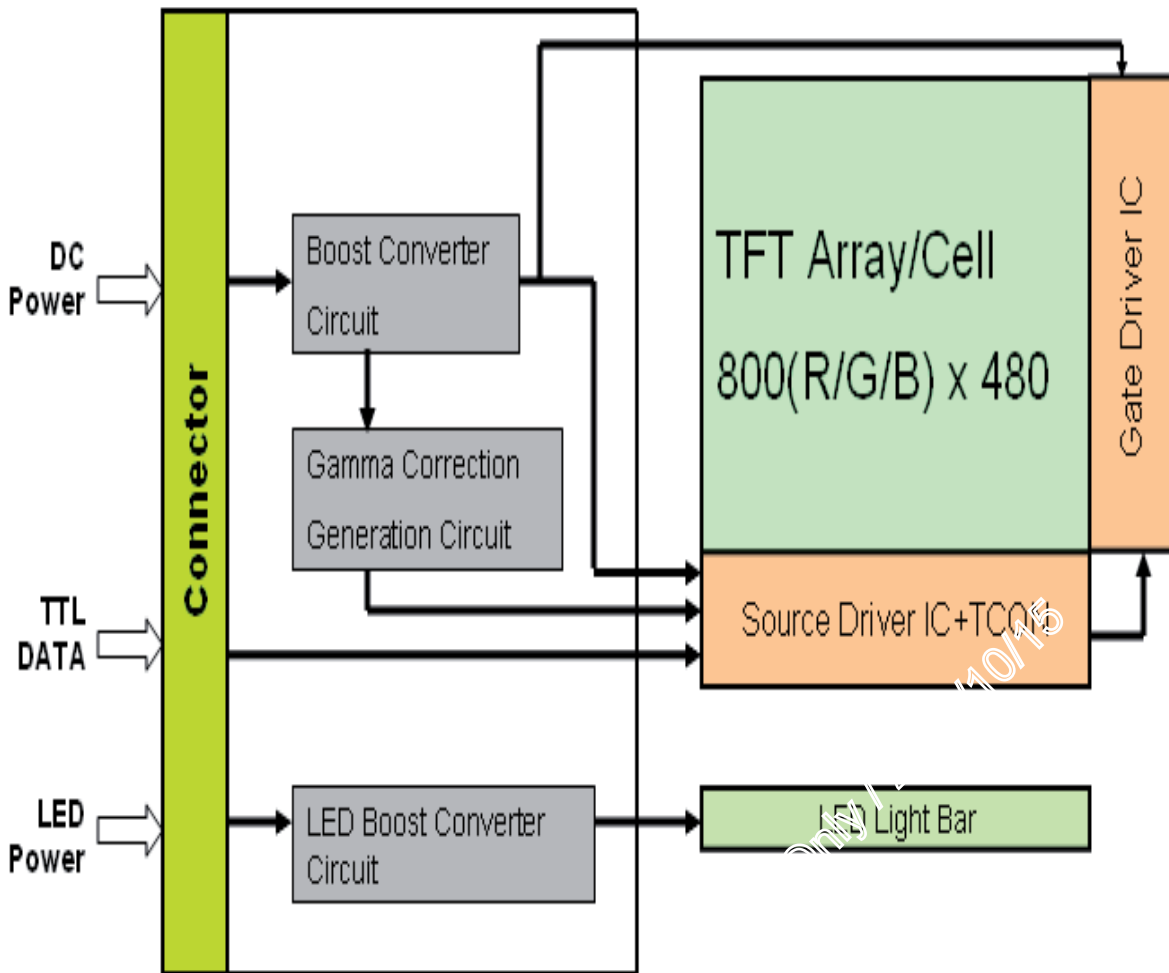



## 4. Absolute Maximum Ratings

### 4.1 Absolute Ratings of TFT LCD Module

Item	Symbol	Min	Max	Unit
Supply Voltage	VDD	-0.3	+4.0	[Volt]

### 4.2 Absolute Ratings of Environment

Item	Symbol	Min	Max	Unit
Operating	TOP	-20	+75	[°C]
Operation Humidity	HOP	10	90	[%RH]
Storage	TST	-30	+80	[°C]
Storage Humidity	HST	10	90	[%RH]

Note: When you apply the LCD module for OA system. Please make sure to keep the temperature of LCD module is less than 75℃

## 5. Electrical Characteristics

### 5.1 TFT LCD Module

#### 5.1.1 Power Specification

Symbol	Parameter	Min	Typ	Max	Units	Remark
VDD	Logic/LCD Drive Voltage	3.0	3.3	3.6	[Volt]	
IDD	VDD Current	-	0.1	-	[A]	
Irush	LCD Inrush Current	-	-	1.5	[A]	Note 1
PDD	VDD Power	-	-	0.7	[Watt]	Black Pattern (60Hz)
VDDrp	Allowable Logic/LCD Drive Ripple Voltage	-	-	200	[mV] p-p	Note 2

Note 1: Measurement condition:

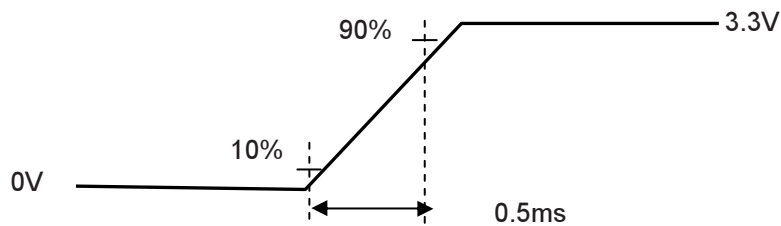

VDD rising time

Note 2: VDD Power Dip Condition

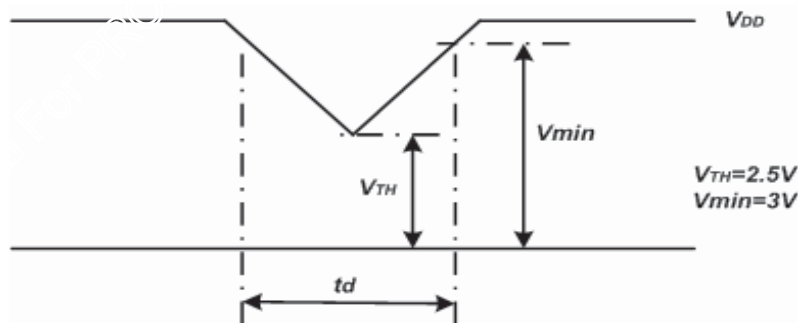

VDD Power Dip

If  $V_{TH} < V_{DD} \leq V_{min}$ , then  $t_d \leq 10ms$ ; When the voltage return to normal our panel must revive automatically.

## 5.2 Backlight Unit

### 5.2.1 Parameter guideline for LED

Following characteristics are measured under a stable condition using an inverter at 25°C (Room Temperature):

Symbol	Parameter	Min.	Typ.	Max.	Units	Condition	
VLED	LED Input	5	12	21	[V]	Ta=25°C Note B	
PLED	LED Power Consumption	-	-	2.1	W	Ta=25°C Note B	
VLED_PWM	PWM Signal Voltage	High	2.5	-	5.5	V	Ta=25°C
		Low	-	-	0.5	V	
F <sub>PWM</sub>	PWM Diming Frequency	100	-	1K	Hz	Ddim ≥ 1%	
		100	-	5K	Hz	Ddim ≥ 5%	
VLED_EN	LED Enable Voltage	High	2.5	-	5.5	V	-
		Low	-	-	0.5	V	
LT	LED Life Time	20,000	-	-	Hours	Ta=25°C Note A	

Note A: The LED life time define as the estimated time to 50% degradation of initial luminous.

Note B: A higher LED power supply voltage will result in better power efficiency. Keep the VLED between 12V and 21V is strongly recommended.

### LED Rush Current Measure Condition

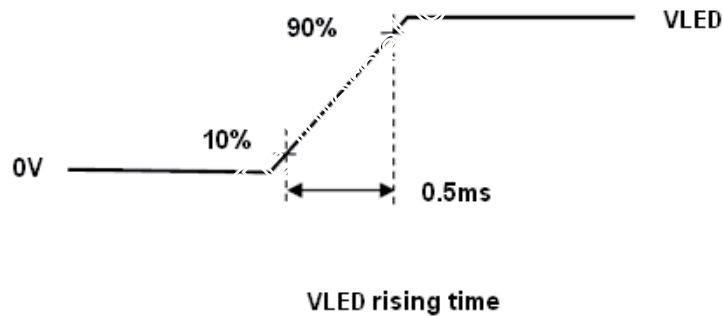

## 6. Signal Characteristic

### 6.1 Pixel Format Image

Following figure shows the relationship between input signal and LCD pixel format.

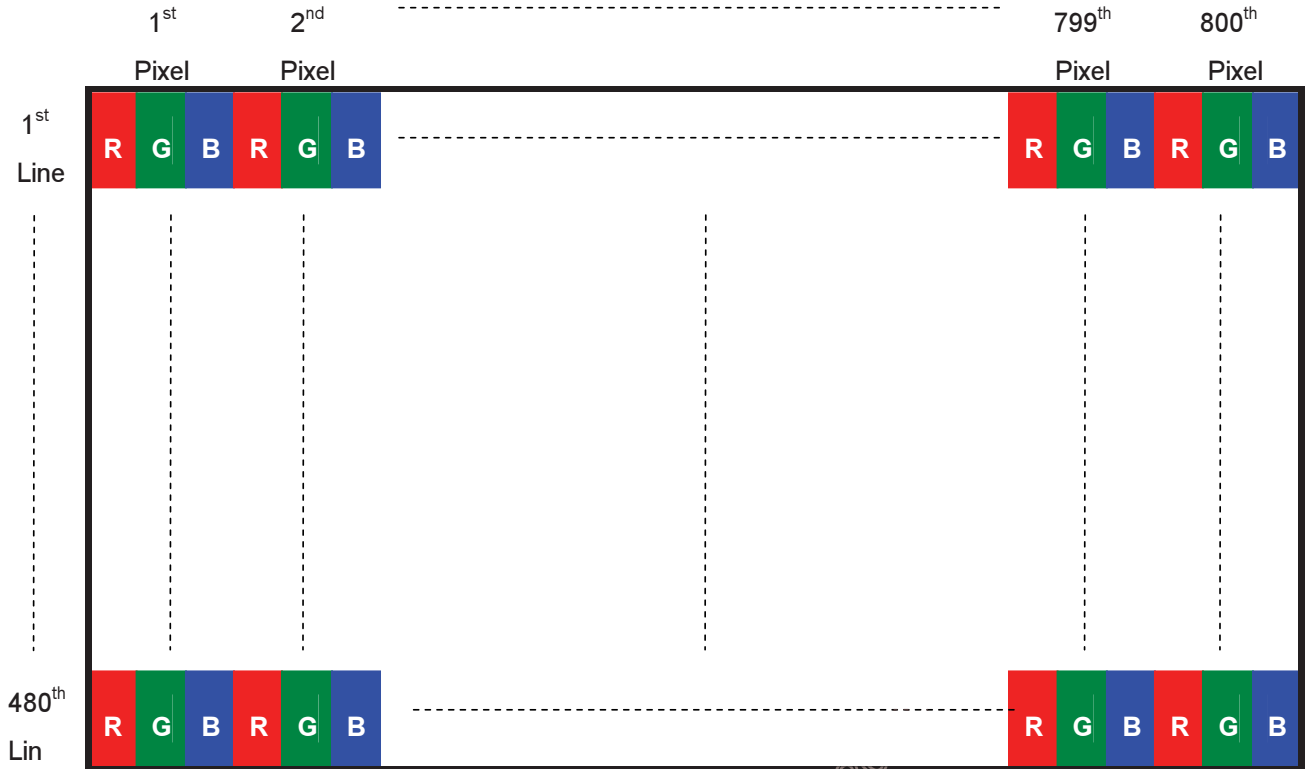

## 6.2 Signal Description

The module uses a TTL receiver and the input signal definition is as below table.

Pin #	Signal Name	Description	Remarks
1	GND	Ground	-
2	GND	Ground	-
3	VDD	Power Supply	<b>3.3V(typical)</b>
4	VDD	Power Supply	<b>3.3V(typical)</b>
5	UPDN	Gate up or down scan control	-
6	SHLR	Source right or left sequence control	-
7	GND	Ground	-
8	R0	Data Input (LSB)	-
9	R1	Data Input	-
10	R2	Data Input	-
11	R3	Data Input	-
12	GND	Ground	-
13	R4	Data Input	-
14	R5	Data Input	-
15	GND	Ground	-
16	R6	Data Input	-
17	R7	Data Input (MSB)	-
18	GND	Ground	--
19	G0	Data Input (LSB)	-
20	G1	Data Input	-
21	G2	Data Input	-
22	G3	Data Input	-
23	GND	Ground	-
24	G4	Data Input	-
25	G5	Data Input	-
26	GND	Ground	-
27	G6	Data Input	-
28	G7	Data Input (MSB)	-
29	GND	Ground	-
30	B0	Data Input (LSB)	-
31	B1	Data Input	-
32	B2	Data Input	-
33	B3	Data Input	-
34	GND	Ground	-
35	B4	Data Input	-
36	B5	Data Input	-
37	GND	Ground	-
38	B6	Data Input	-

39	B7	Data Input (MSB)	-
40	GND	Ground	-
41	DCLK	Clock Input	-
42	GND	Ground	-
43	DE	Data Input Enable	-
44	BIST	Aging Mode	High Enable
45	GND	Ground	-
46	GND	Ground	-
47	LED PWM	System PWM Signal Input	-
48	LED EN	LED Enable Pin	-
49	VLED	LED Power Supply	-
50	VLED	LED Power Supply	-

Note1: When input 18 bits RGB data, the two low bits of R, G and B data must be grounded.

Note2: Data shall be latched at falling edge of DCLK.

Note3: Selection of scanning mode.

Setting of scan control input		Scanning Direction
SHLR	UPDN	
VDD	GND	Left to Right, Up to Down
GND	GND	Right to Left, Up to Down
VDD	VDD	Left to Right, Down to Up

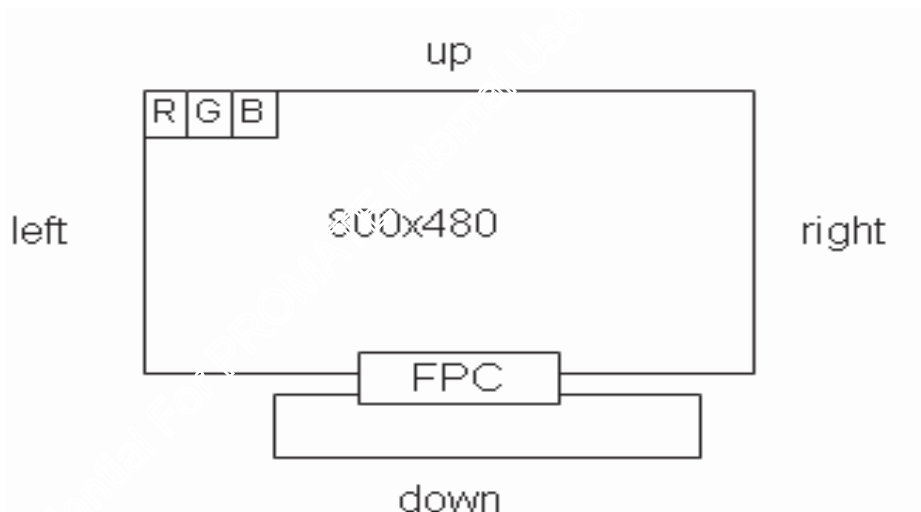

## 6.3 Interface Timing

### 6.3.1 Timing Characteristics

Synchronization Method : DE only

Parameter	Symbol	Min	Typ	Max	Unit	Note
CLKIN Cycle Time	Tcph	20	-	-	ns	-
CLKIN Pulse Duty	Tcyyh	40	50	60	%	-
Data Set-up Time	Tdsu	8	-	-	ns	-
Data Hold Time	Tdhd	8	-	-	ns	-
DE Set-up Time	Tesu	8	-	-	ns	-
DE Hold Time	Tehd	8	-	-	ns	-
Output Stable Time	Tsst	-	-	6	us	-
DCLK Frequency	Fclk	28	30	40	MHz	-
Horizontal Display Area	Thd	800			DCLK	-
One Horizontal Line	Th	908	928	1080	DCLK	-
H Blank Area	Th-blank	108	128	-	DCLK	-
Vertical Display Area	Tyd	480			H	-
V Period time	Ty	517	525	704	H	-
V Blank Area	Ty-blank	37	45	224	H	-

Note: H Blank area and V Blank area can not be changed at every frame

## DC Electrical

(VDD=2.7 to 3.6V ,TA=-20 to +85□)

Parameter	Symbol	Min.	Typ.	Max.	Unit	Conditions
Low level input voltage	Vil	0	-	0.3*VDD	V	For the digital circuit
High level input voltage	Vih	0.7*VDD	-	VDD	V	For the digital circuit



## 6.3.2 Input Timing Diagram

### Timing Characteristics

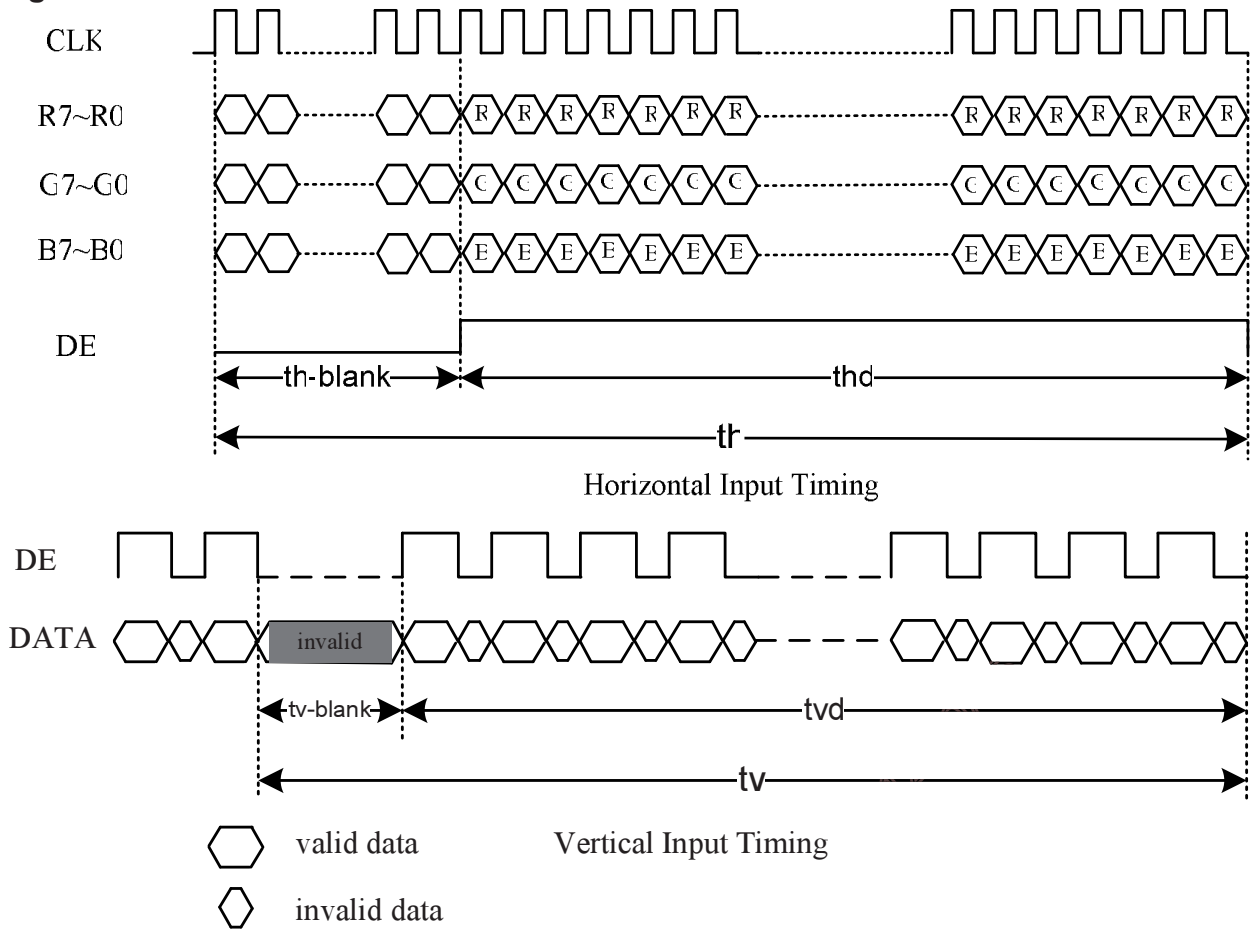

## 6.4 Power ON/OFF Sequence

VDD power on/off sequence is as follows. Interface signals are also shown in the chart. Signals from any system shall be Hi-Z state or low level when VDD is off.

### Power Sequence

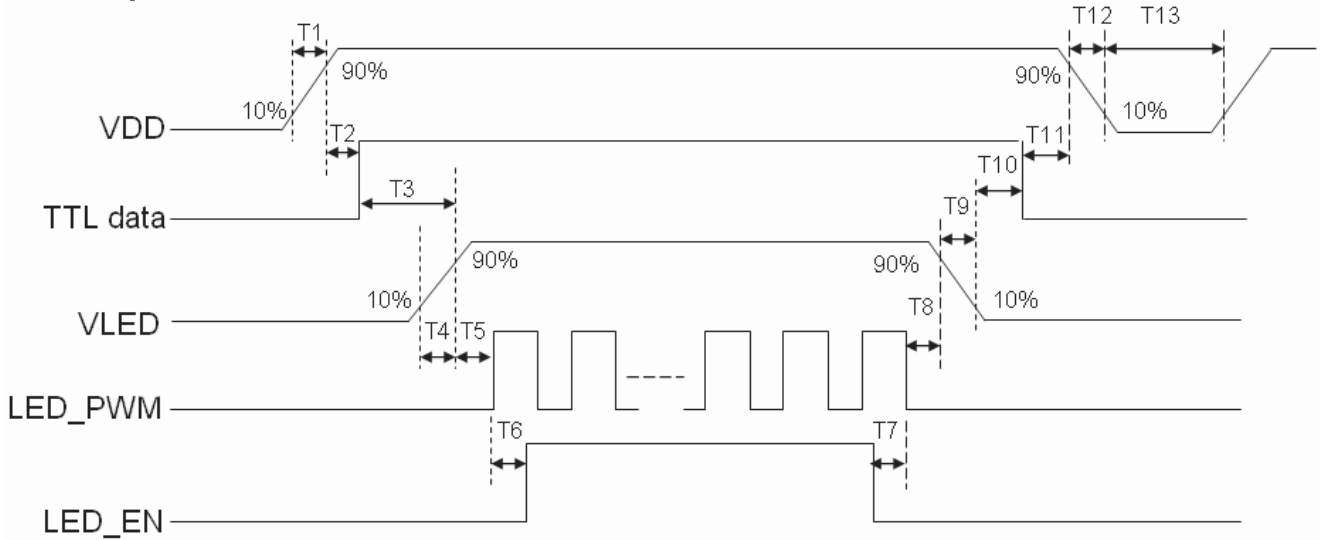

### Power Sequencing Requirements

Parameter	Symbol	Unit	Min	Typ	Max
VDD Rise Time	T1	ms	0.5	--	10
VDD Good to Signal Valid	T2	ms	30	--	90
Signal Valid to Backlight On	T3	ms	200	--	--
Backlight Power On Time	T4	ms	0.5	--	--
Backlight Power Good to System PWM On	T5	ms	10	--	--
System PWM ON to Backlight Enable On	T6	ms	10	--	--
Backlight Enable Off to System PWM Off	T7	ms	0	--	--
System PWM Off to B/L Power Disable	T8	ms	10	--	--
Backlight Power Off Time	T9	ms	--	10	30
Backlight Off to Signal Disable	T10	ms	200	--	--
Signal Disable to VDD Down	T11	ms	0	--	50
VDD Fall Time	T12	ms	1	--	30
VDD Off Time	T13	ms	500	--	--

## 7. Connector & Pin Assignment

Physical interface is described as for the connector on module. These connectors are capable of accommodating the following signals and will be following components.

### 7.1 TFT LCD Module: Connector information

Connector Name / Designation	Signal Connector
Manufacturer	Starconn or compatible
Connector Model Number	089H50-000000-G2-R or compatible

Pin No.	Symbol	Pin No.	Symbol
1	GND	26	GND
2	GND	27	G6
3	VDD	28	G7
4	VDD	29	GND
5	UPDN	30	B0
6	SHLR	31	B1
7	GND	32	B2
8	R0	33	B3
9	R1	34	GND
10	R2	35	B4
11	R3	36	B5
12	GND	37	GND
13	R4	38	B6
14	R5	39	B7
15	GND	40	GND
16	R6	41	DCLK
17	R7	42	GND
18	GND	43	DE
19	G0	44	BIST
20	G1	45	GND
21	G2	46	GND
22	G3	47	LED_PWM
23	GND	48	LED_EN
24	G4	49	VLED
25	G5	50	VLED

## 8. Reliability Test Criteria

Item	Criterion
A	There is no function defect and occurrence of any new defective shall not be allowed.
B	In case of malfunction defect caused by ESD damage. If it would be recovered to normal state after resetting, it would be judge as pass.
C	Image Sticking is not visible through 8% ND filter after 10 mins with pattern L127.

Item	Package	Test Conditions	Conditions
High Temperature Storage Test	Module	80°C, 300hrs	A
Low Temperature Storage Test	Module	-30°C, 300hrs	A
High Temp./High Humidity Storage Test	Module	50°C, 90%, 300hrs	A
High Temperature Operation Test	Module	75°C, 300hrs	A
Low Temperature Operating Test	Module	-20°C, 300hrs	A
High Temp./High Humidity Operating Test	Module	50°C, 90%, 300hrs	A
Thermal Shock Non-operation Test	Module	-30°C ~ 80°C; 1hr/each cycle, 200cycles	A
Shock Test	With package	Half Sine Wave ±X, Y, Z 240G, 2ms, 1 Times each axis	A
Vibration Test	With package	1.5G, 10~500 Hz, x, y, z each axis/1h	A
ESD Test	Module	<contact> operate ±8kV <Air> operate ±15kV	B
Image Sticking test	Module	25°C, chess pattern (5*7) test 8hrs	C

Note: 1. In Operating test, the B/L voltage and current must be in spec.

2. All the judgments are under normal temperature and the sample need to be static more than 2 hours in the normal temperature before judge.

3. During measurement, the condensation water or remains shall not be allowed.

4. The minimum sample quantity of test is 3pcs.

5. There is no display function fail issue occurred, all the cosmetic specification is judged before the reliability stress.

## 9. Mechanical Characteristics

### 9.1 LCM Outline Dimension (Front View)

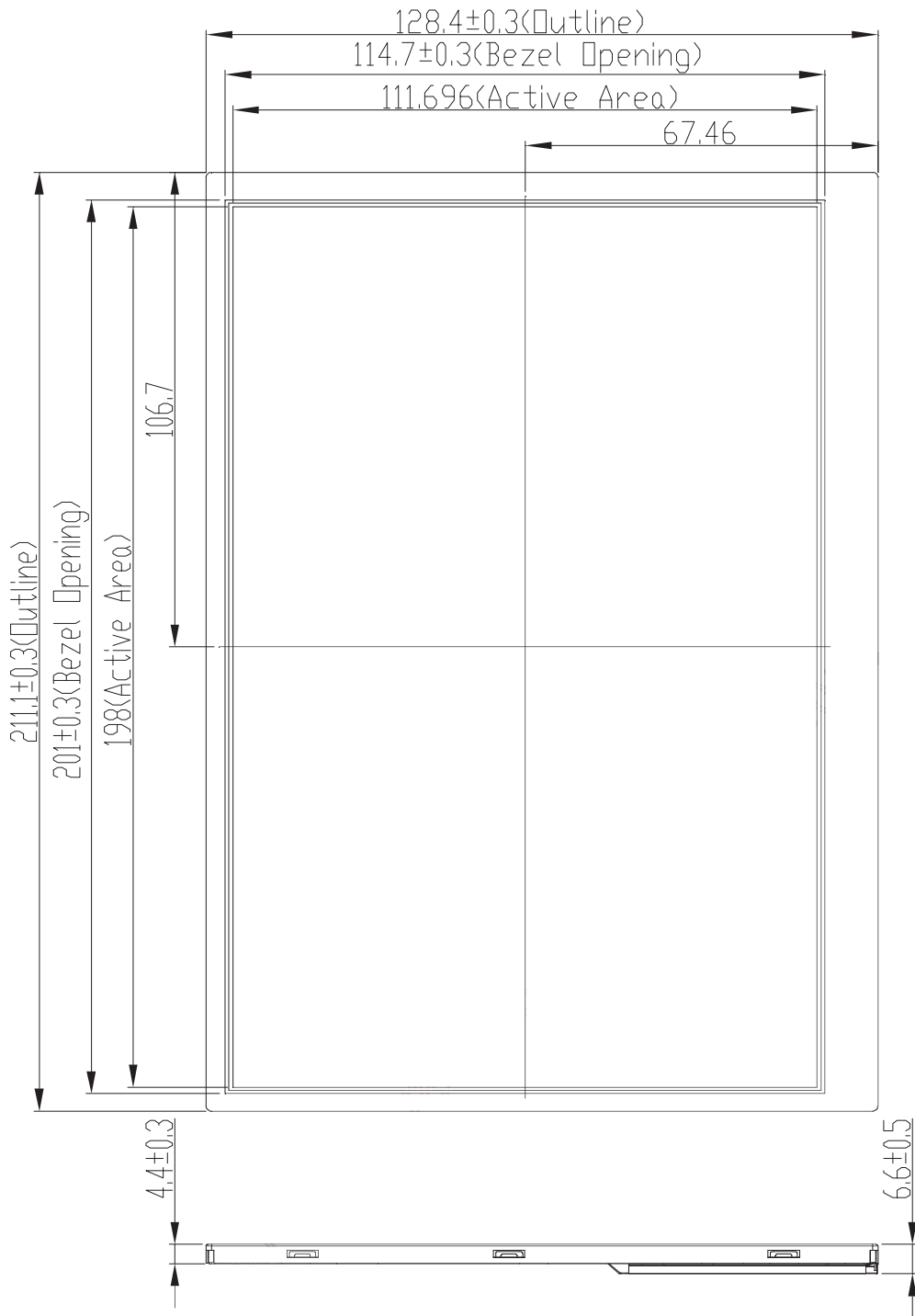

**9.2 LCM Outline Dimension (Rear View)**

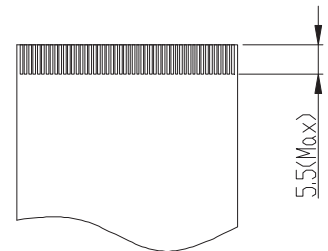
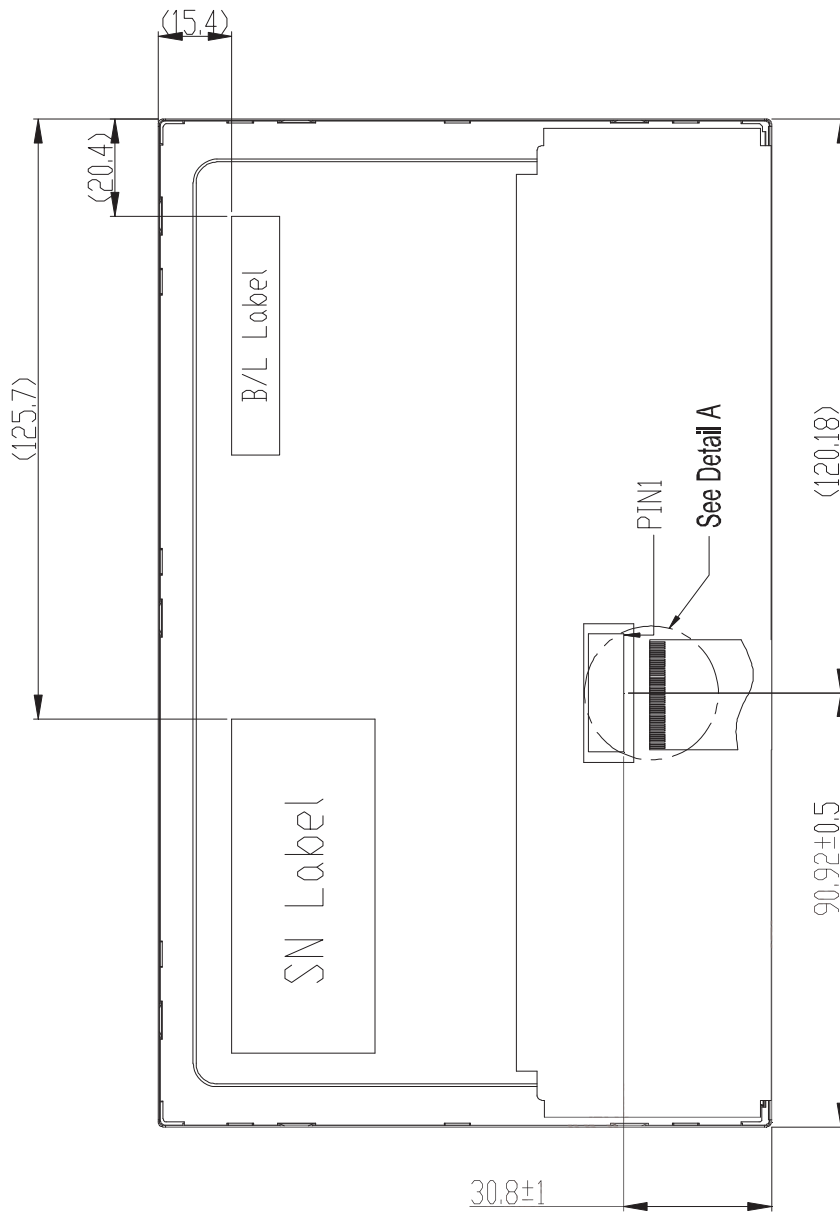

Detail A  
 Scale 2:1

## 10. Label and Packaging

### 10.1 Shipping Label (on the rear side of TFT-LCD display)



### 10.2 Carton Package

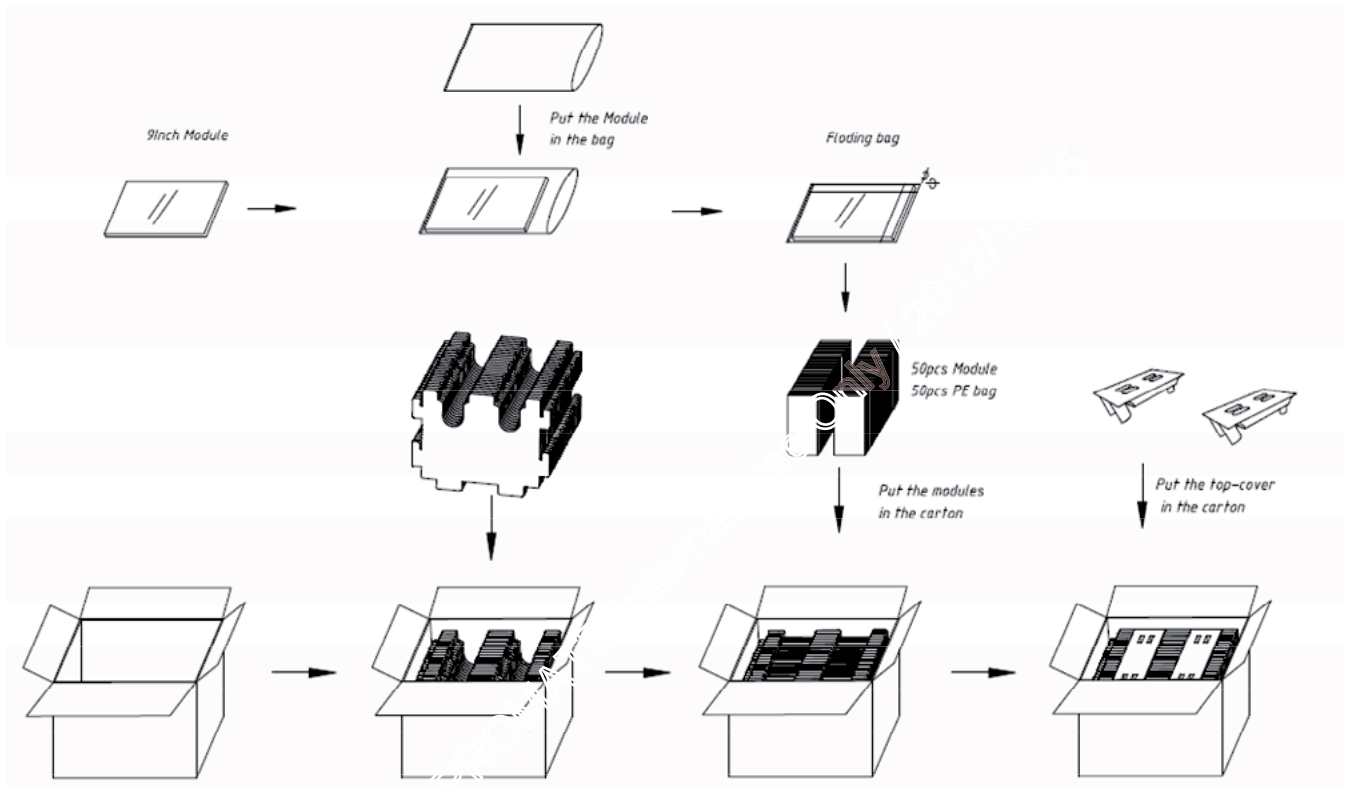

**Note:**

**Max. Capacity: 50 LCD Modules/Carton**

**Max. Weight: 15.5Kg / per Carton**