

## General Description

The G1007. combines advanced trench MOSFET technology with a low resistance package to provide extremely low  $R_{DS(ON)}$ . This device is ideal for power switching application and LED backlighting.

## Features

VDSS	RDS(ON) @10V (typ)	ID
100V	70mΩ	7A

- Ultra Low On-Resistance
- High UIS and UIS 100% Test

## Application

- Power switching application
- LED backlighting

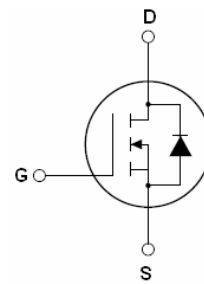

Schematic Diagram

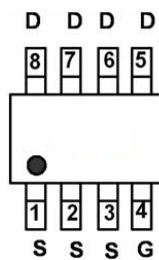

Marking and pin Assignment

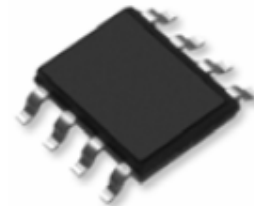

SOP-8

**Table 1. Absolute Maximum Ratings (TA=25°C)**

Symbol	Parameter	Value	Unit
$V_{DS}$	Drain-Source Voltage ( $V_{GS}=0V$ )	100	V
$V_{GS}$	Gate-Source Voltage ( $V_{DS}=0V$ )	±20	V
$I_{D(DC)}$	Drain Current (DC) at $T_c=25^\circ C$	7	A
$I_{D(DC)}$	Drain Current (DC) at $T_c=100^\circ C$	8.5	A
$I_{DM(pluse)}$	Drain Current-Continuous@ Current-Pulsed (Note 1)	56	A
$P_D$	Maximum Power Dissipation( $T_c=25^\circ C$ )	28	W
$E_{AS}$	Single Pulse Avalanche Energy (Note 2)	16	mJ
$T_J, T_{STG}$	Operating Junction and Storage Temperature Range	-55 To 175	°C

Notes 1.Repetitive Rating: Pulse width limited by maximum junction temperature

2.EAS condition: $T_J=25^\circ C, V_{DD}=50V, V_G=10V, R_G=25\Omega$

**Table 2. Thermal Characteristic**

Symbol	Parameter	Value	Unit
$R_{\theta JC}$	Thermal Resistance, Junction-to-Case	3.3	$^{\circ}C/W$

**Table 3. Electrical Characteristics (TA=25 $^{\circ}C$  unless otherwise noted)**

Symbol	Parameter	Conditions	Min	Typ	Max	Unit
<b>On/Off States</b>						
$BV_{DSS}$	Drain-Source Breakdown Voltage	$V_{GS}=0V, I_D=250\mu A$	100			V
$I_{DSS}$	Zero Gate Voltage Drain Current(Tc=25 $^{\circ}C$ )	$V_{DS}=100V, V_{GS}=0V$			1	$\mu A$
$I_{DSS}$	Zero Gate Voltage Drain Current(Tc=100 $^{\circ}C$ )	$V_{DS}=100V, V_{GS}=0V$			5	$\mu A$
$I_{GSS}$	Gate-Body Leakage Current	$V_{GS}=\pm 20V, V_{DS}=0V$			$\pm 100$	nA
$V_{GS(th)}$	Gate Threshold Voltage	$V_{DS}=V_{GS}, I_D=250\mu A$	1.5	2.0	2.6	V
$R_{DS(ON)}$	Drain-Source On-State Resistance	$V_{GS}=10V, I_D=4.5A$		70	85	m $\Omega$
<b>Dynamic Characteristics</b>						
$g_{FS}$	Forward Transconductance	$V_{DS}=5V, I_D=4.5A$	5			S
$C_{iss}$	Input Capacitance	$V_{DS}=50V, V_{GS}=0V$ $f=1.0MHz$		612		PF
$C_{oss}$	Output Capacitance			120		PF
$C_{riss}$	Reverse Transfer Capacitance			91		PF
$Q_g$	Total Gate Charge	$V_{DS}=50V, I_D=4.5A$ $V_{GS}=10V$		11		nC
$Q_{gs}$	Gate-Source Charge			1.9		nC
$Q_{gd}$	Gate-Drain Charge			2.8		nC
<b>Switching Times</b>						
$t_{d(on)}$	Turn-on Delay Time	$V_{DS}=50V, R_L=8.6\Omega$ $V_{GS}=10V, R_G=3\Omega$		8		nS
$t_r$	Turn-on Rise Time			3		nS
$t_{d(off)}$	Turn-Off Delay Time			17		nS
$t_f$	Turn-Off Fall Time			4.5		nS
<b>Source-Drain Diode Characteristics</b>						
$I_{SD}$	Source-Drain Current(Body Diode)			14		A
$I_{SDM}$	Pulsed Source-Drain Current(Body Diode)			56		A
$V_{SD}$	Forward On Voltage <sup>(Note 1)</sup>	$T_J=25^{\circ}C, I_{SD}=1A, V_{GS}=0V$		0.74	1	V
$t_{rr}$	Reverse Recovery Time <sup>(Note 1)</sup>	$T_J=25^{\circ}C, I_F=4.5A$ $di/dt=500A/\mu s$		21		nS
$Q_{rr}$	Reverse Recovery Charge <sup>(Note 1)</sup>			97		nC
$t_{on}$	Forward Turn-on Time	Intrinsic turn-on time is negligible(turn-on is dominated by $L_S+L_D$ )				

Notes 1. Pulse Test: Pulse Width  $\leq 300\mu s$ , Duty Cycle  $\leq 1.5\%$ , Starting  $T_J=25^{\circ}C$

## Test Circuit

### 1) $E_{AS}$ Test Circuits

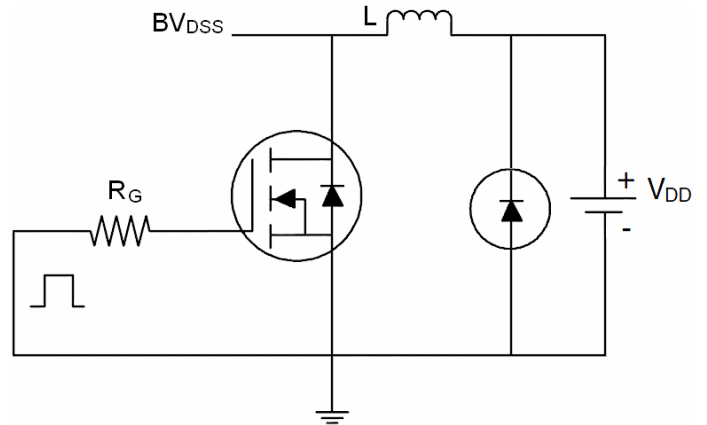
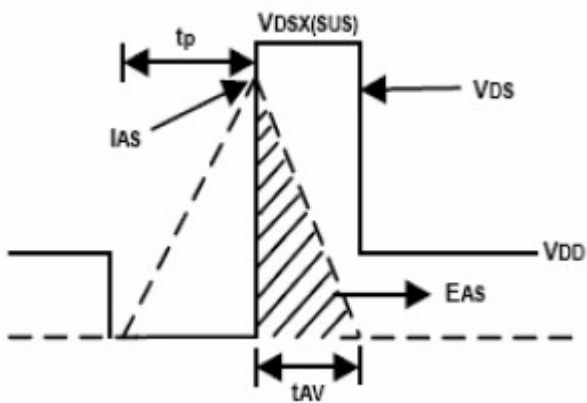

### 2) Gate Charge Test Circuit:

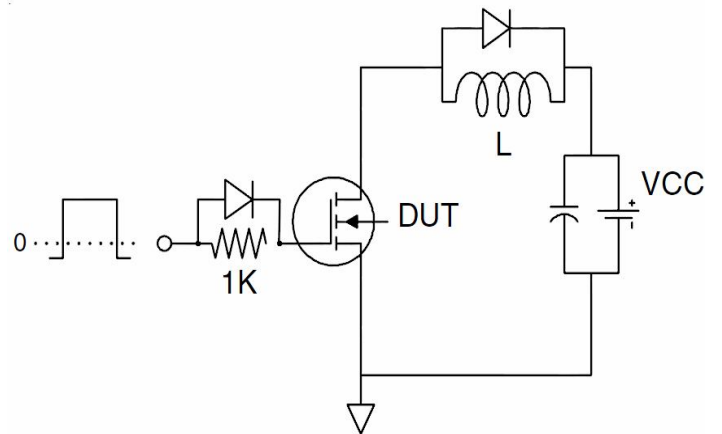
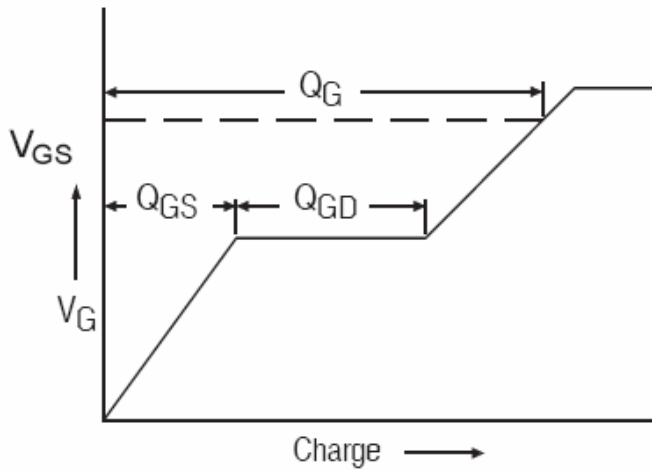

### 3) Switch Time Test Circuit:

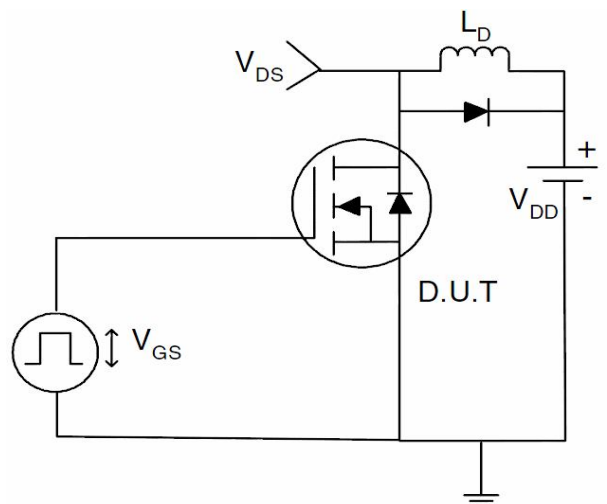
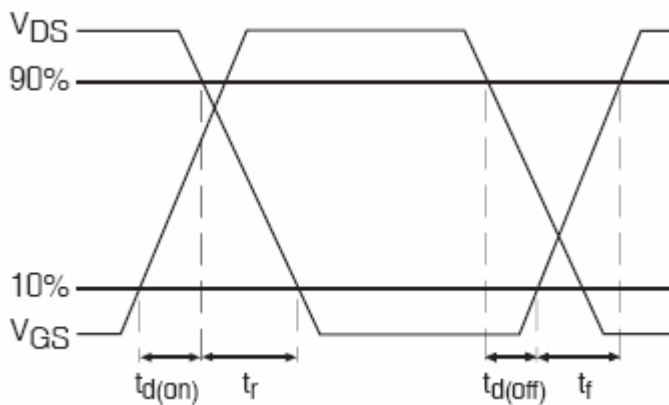

TYPICAL ELECTRICAL AND THERMAL CHARACTERISTICS (Curves)

Figure1. On-Region Characteristics

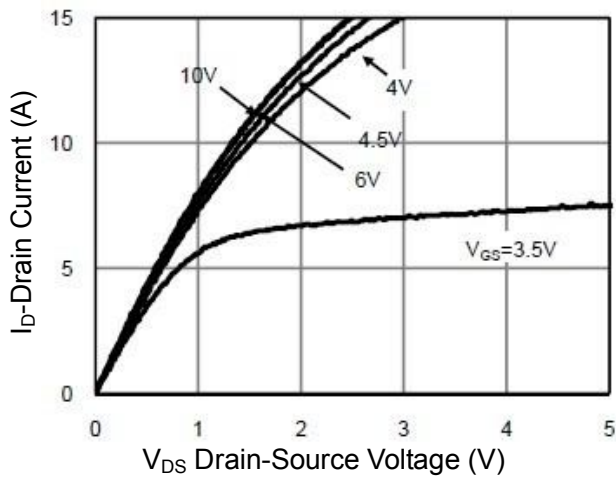

Figure 2: Transfer Characteristics

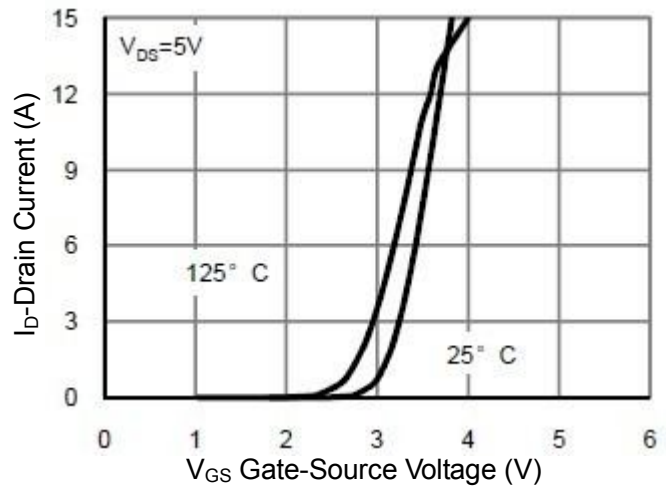

Figure3. On-Resistance vs. Drain Current and Gate Voltage

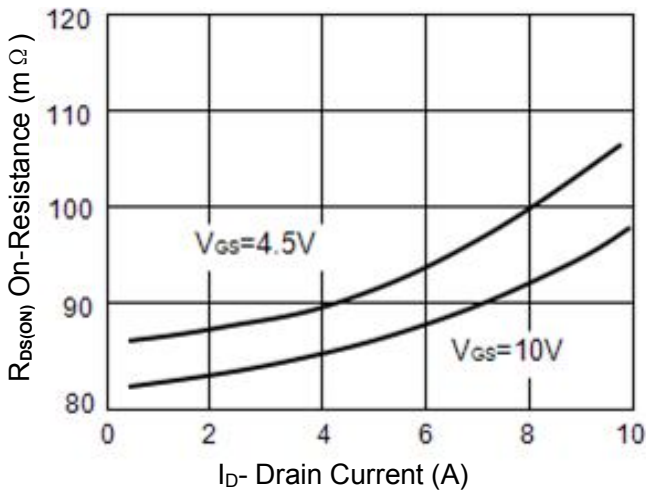

Figure4. On-Resistance vs. Junction Temperature

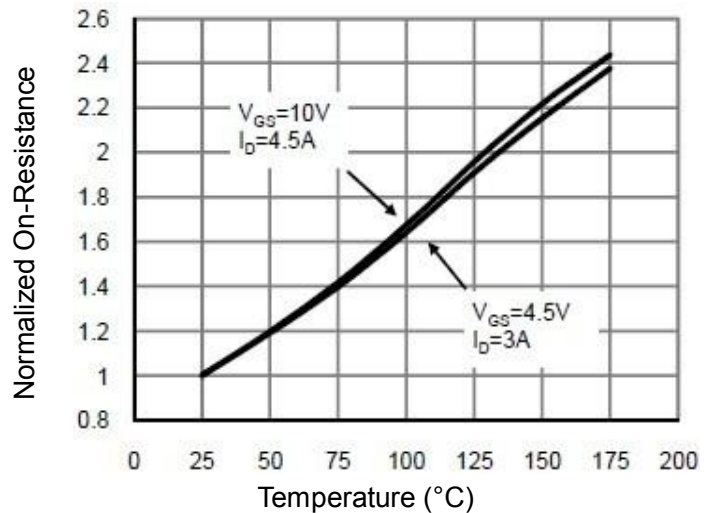

Figure5. On-Resistance vs. Gate-Source Voltage

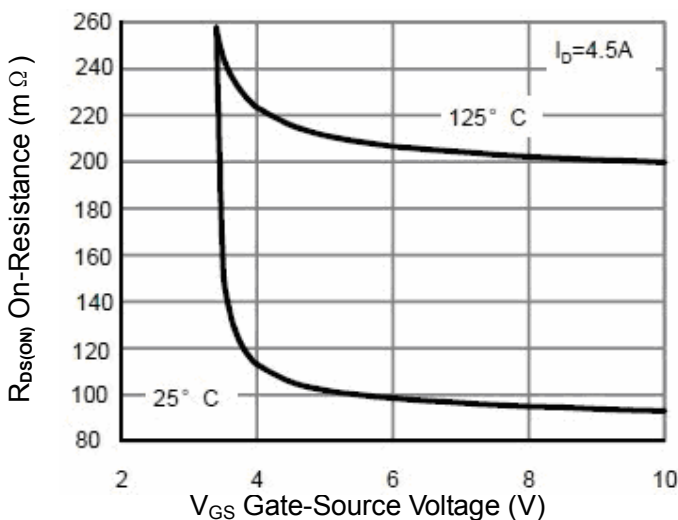

Figure6. Body-Diode Characteristics

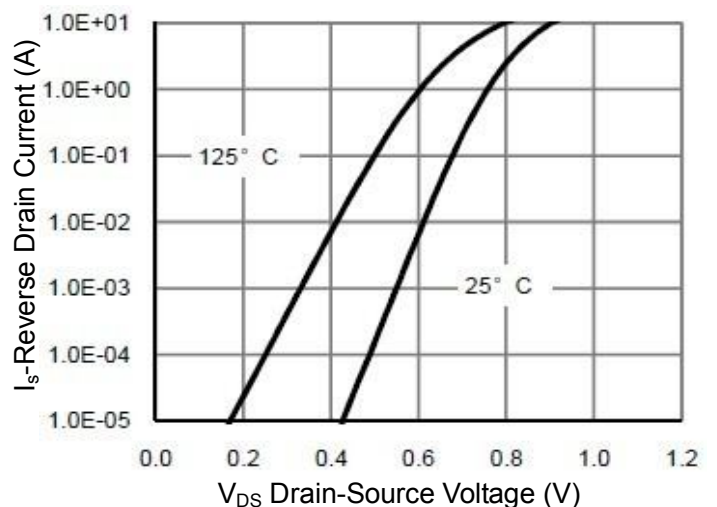

Figure 7. Gate-Charge Characteristics

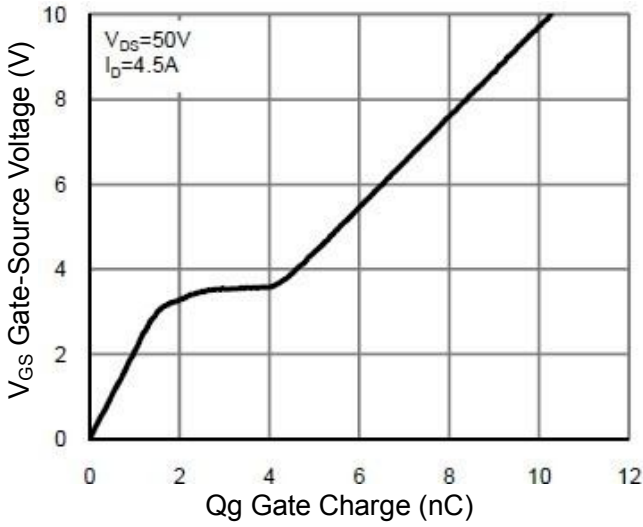

Figure 8. Capacitance Characteristics

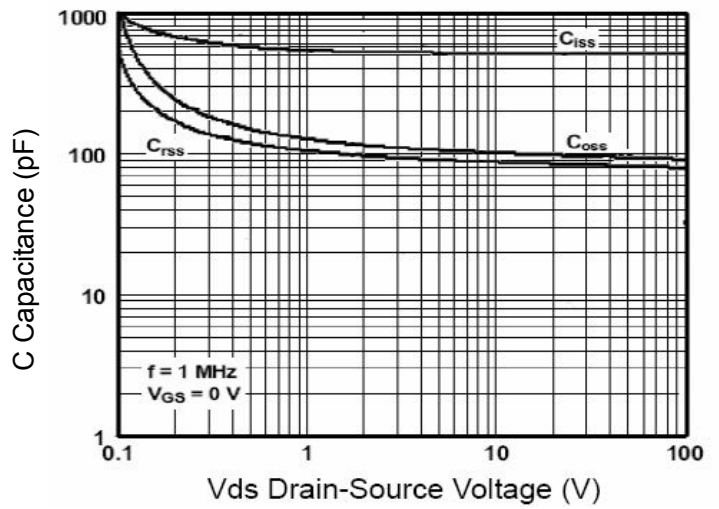

Figure 9. Maximum Forward Biased Safe Operating Area

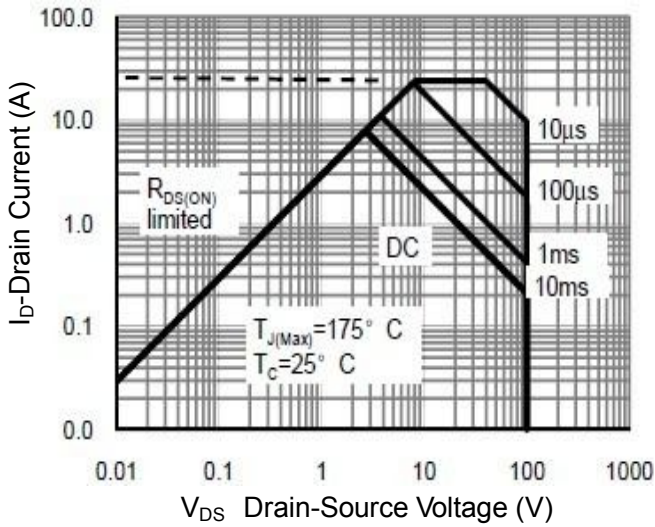

Figure 10. Single Pulse Power Rating Junction-to-Case

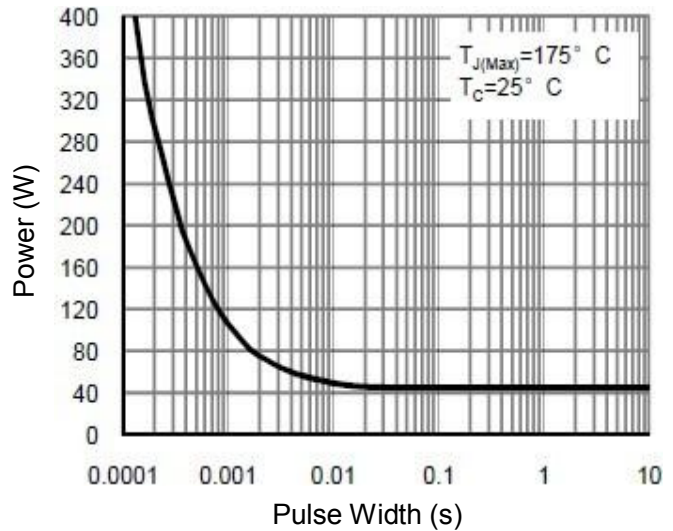

Figure 11. Normalized Maximum Transient Thermal Impedance

