

LIQUID CRYSTAL DISPLAY MODULE

G121C0DX000

G121C0AX000

USER'S MANUAL

Seiko Instruments Inc.

NOTICE

This manual describes the technical information, as well as the functions and operation of the G121C Liquid Crystal Display Module made by Seiko Instruments Inc. Please read this manual carefully to familiarize yourself with the functions, so you can make the best use of them.

The descriptions here are subject to change without notice.

Revision Record

<u>Edition</u>	<u>Revision</u>	<u>Date</u>
1	Original	Nov. 1995

© Seiko Instruments Inc. 1995

Printed in Japan

CONTENTS

1. SPECIFICATIONS	
1.1 General	1
1.2 Features	1
1.3 Absolute Maximum Ratings	2
1.4 Mechanical Characteristics	2
1.5 Electrical Characteristics	2
1.6 Optical Characteristics	3
1.7 LCD Panel Lifetime	5
1.8 Dimensions	6
2. CIRCUIT CONFIGURATION	
2.1 Liquid Crystal Driving Circuit	7
2.2 Circuit Configuration	10
2.3 Timing Characteristics	14
2.4 Interface Circuit	16
2.5 Examples of Command Setting to SED1351F0A	18
3. PRECAUTIONS	20

INDEX

1. SPECIFICATIONS

1.1 General

The G121C is a very thin LCD module on which a full-dot matrix ECB (Electric Controlled Birefringence) color LCD panel and CMOS IC drivers are integrated. The ECB color LCD panel used here features nice discrimination viewing angle and high contrast. This full dot configuration allows a wide variety of patterns to be displayed depending upon the input data. The display position is the intersection point of the matrix transparent electrodes. This prevents display distortion and displacement.

The ECB LCD can be easily performed some colors on the display using same controllers as gray scale of monochrome display.

1.2 Features

- 128×128 full dot matrix configuration
- 1/128 duty, 1/10 bias
- 4-bit parallel data input
- Dual power supplies : $V_{DD} = +5\text{ V}$, $V_{LC} = -15\text{ V}$ (for driving liquid crystal)
- STN LCD
- Reflective type
- ECB color mode
- 6 o'clock viewing angle
- Display colors:
 - G121C0DX000: 4 colors (Red, White, Green, Blue)
 - G121C0AX000: 3 colors (Red, Yellow, Black)

1.3 Absolute Maximum Ratings

V_{SS} = 0 V

Item	Symbol	Conditions	Min.	Max.	Unit
Power supply voltage	V _{DD}		- 0.3	7.0	V
	V _{LC}		V _{DD} - 30.0	V _{DD}	V
	V _O	V _O ≥ V _{LC}	V _{DD} - 30.0	V _{DD}	V
Input voltage	V _{IN}		- 0.3	V _{DD} + 0.3	V
Operating temperature	T _{opr}	≤ 65%RH	0	+ 60	°C
Storage temperature	T _{stg}		- 20	+ 70	°C
Storage humidity		≤ 48 hrs	+ 20	+ 85	%RH
		≤ 1000 hrs	+ 20	+ 65	%RH

1.4 Mechanical Characteristics

Item	Standard
Dot configuration [dots]	128 × 128
Module dimensions (H × V × T) [mm]	86.0 × 95.0 × 7.0 max.
Viewing area (H × V) [mm]	67.4 × 67.4
Active display area (H × V) [mm]	62.69 × 62.69
Dot dimensions (H × V) [mm]	0.46 × 0.46
Dot pitch (H × V) [mm]	0.49 × 0.49
Weight [g]	75 max.

H : Horizontal, V : Vertical, T : Thickness (max.)

1.5 Electrical Characteristics

V_{SS} = 0 V, Ta = 0°C ~ +60°C

Item	Symbol	Conditions	Min.	Typ.	Max.	Unit
Power supply voltage	V _{DD}		4.75	5.00	5.25	V
	V _{LC}	V _{DD} = 5 V	- 15.5	- 15.0	- 14.5	V
	V _O *1		V _{LC} + 1	-	V _{DD} - 1	V
Input voltage	High	V _{DD} = 5.0 ± 5%	0.8 V _{DD}	-	V _{DD}	V
	Low		V _{IL}	0	-	0.2 V _{DD}
Current consumption*2	I _{DD}	V _{DD} = 5 V, Ta = 25°C V _O = - 12.0 V V _{LC} = - 15.0 V	-	5.5	11.0	mA
	I _{LC}		-	5.3	10.6	mA
Frame frequency*3	f _{FLM}		240	250	260	Hz

*1 V_O = (V_{LC} + 1)

*2 Display data shift clock frequency: f_{CL2} = 2.0 MHz f_{FLM} = 250Hz

Display patterns:

- G121C0DX000 : Red and Blue 1dot checkered patterns.
- G121C0AX000 : Red and Black 1dot checkered patterns.

*3 LCD controller: SED1351F0A(EPSON)

1.6 Optical Characteristics

1.6.1 G121C0DX000

(1) Characteristics table

1/128 duty, 1/10 bias, $f_{FLM} = 250 \text{ Hz}$, $V_{opr} = V_{DD} - V_O$

Item	Symbol	Conditions*1	Temp.	Min.	Typ.	Max.	Unit	Reference	
Contrast	C	$\theta = 0^\circ, \phi = 0^\circ$ $V_{opr} = 17.0 \text{ V}$	25°C	2.0	2.5	-	-	Note 1	
Colors	Red	*4	25°C	-	12.3	-	-	-	
				x	-	0.378			-
				y	-	0.290			-
	White			Y	-	15.3			-
				x	-	0.330			-
				y	-	0.406			-
	Green*5			Y	-	12.7			-
				x	-	0.250			-
				y	-	0.386			-
	Blue			Y	-	6.2			-
				x	-	0.218			-
				y	-	0.196			-
Response time	t_{on}	$\theta = 0^\circ$ $\phi = 0^\circ$ $V_{opr} = 17.0 \text{ V}$	0°C	-	1800	2300	ms	Note 2	
	t_{off}			-	1600	2200			
	t_{on}	$\theta = 0^\circ$ $\phi = 0^\circ$ $V_{opr} = 17.0 \text{ V}$	25°C	-	370	480			
	t_{off}			-	400	520			
Operating voltage	V_{opr}	*2	25°C*3	16.0	17.0	18.0	V		

Measuring instrument:

Chromaticity & color difference meter : CR-200 (MINOLTA),
Illuminometer: LC-35 (CANON)

- *1 Angle " $\theta = 0^\circ, \phi = 0^\circ$ " means right angle with the LCD/LCM display surface.
- *2 Operating voltage means the condition that 4 colors (Red, White, Green and Blue) are displayed at good balance.
- *3 Operating voltage fluctuation at operating temperature range "0°C to 60°C" is within approximately $\pm 0.3\text{V}$ from the specified voltage at 25°C.
- *4 See refer to Table 3 of page 9.
- *5 Some stripes may be appeared on the display pattern according to the difference of wiring resistance.

(2) Effective voltage vs Reflectance & Display color

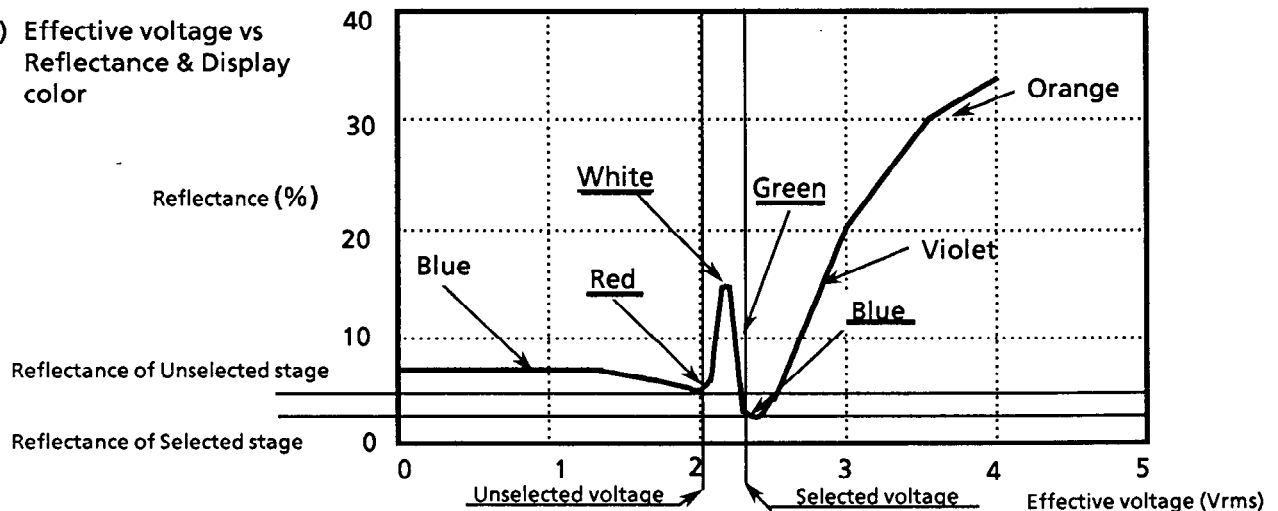

1.6.2 G121C0AX000

(1) Characteristics table

1/128 duty, 1/10 bias, $f_{FLM} = 250 \text{ Hz}$, $V_{opr} = V_{DD} - V_O$

Item	Symbol	Conditions*1	Temp.	Min.	Typ.	Max.	Unit	Reference	
Contrast	C	$\theta = 0^\circ, \phi = 0^\circ$ $V_{opr} = 17.0 \text{ V}$	25°C	3.0	3.5	-	-	Note 1	
Colors	Red	Y	*4	25°C	-	12.9	-	-	-
		x			-	0.419	-		
		y			-	0.346	-		
	Yellow	Y			-	16.0	-		
		x			-	0.337	-		
		y			-	0.377	-		
	Black	Y			-	4.2	-		
		x			-	0.276	-		
		y			-	0.245	-		
Response time	t_{on}	$\theta = 0^\circ$ $\phi = 0^\circ$	0°C	-	1800	2300	ms	Note 2	
	t_{off}	$V_{opr} = 17.0 \text{ V}$		-	1600	2200			
	t_{on}	$\theta = 0^\circ$ $\phi = 0^\circ$	25°C	-	370	480			
	t_{off}	$V_{opr} = 17.0 \text{ V}$		-	400	520			
Operating voltage	V_{opr}	*2	25°C *3	16.0	17.0	18.0	V		

Measuring instrument:

Chromaticity & color difference meter : CR-200 (MINOLTA),
Illuminometer: LC-35 (CANON)

- *1 Angle " $\theta = 0^\circ, \phi = 0^\circ$ " means right angle with the LCD/LCM display surface.
- *2 Operating voltage means the condition that 3 colors (Red, Yellow, Black) are displayed at good balance.
- *3 Operating voltage fluctuation at operating temperature range "0°C to 60°C" is within approximately $\pm 0.3\text{V}$ from the specified voltage at 25°C.
- *4 See refer to Table 3 of page 9.

(2) Effective voltage vs Reflectance vs Display color

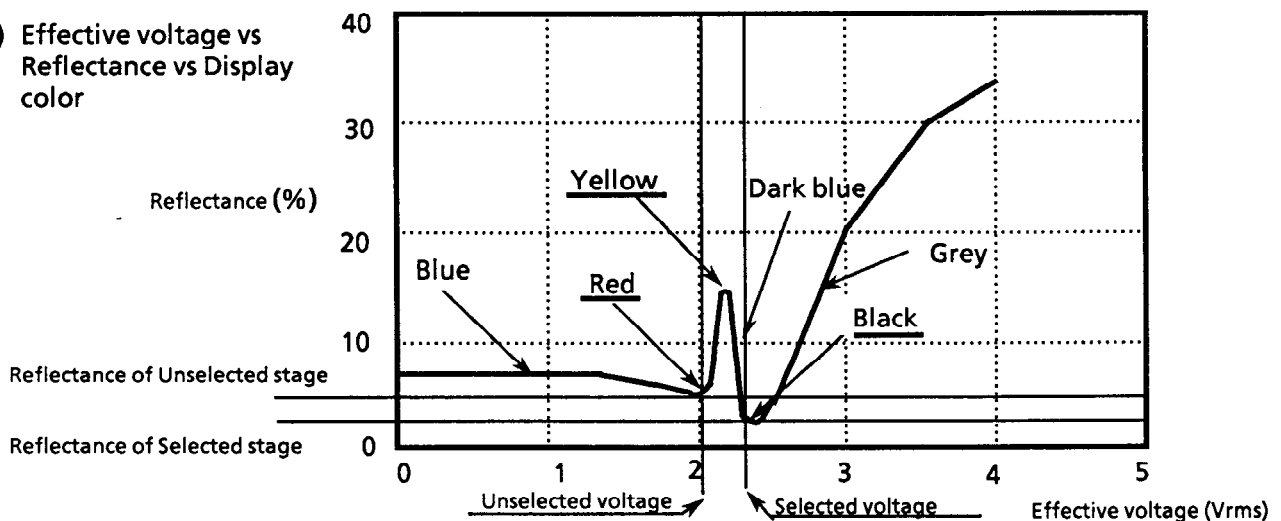

Note 1: Definition of contrast (C)

[G121C0DX000]

$$C = \frac{\text{Reflectance of selected area (White) } B_2}{\text{Reflectance of selected area (Blue) } B_1}$$

[G121C0AX000]

$$C = \frac{\text{Reflectance of selected area (Yellow) } B_2}{\text{Reflectance of selected area (Black) } B_1}$$

Note 2: Definition of response

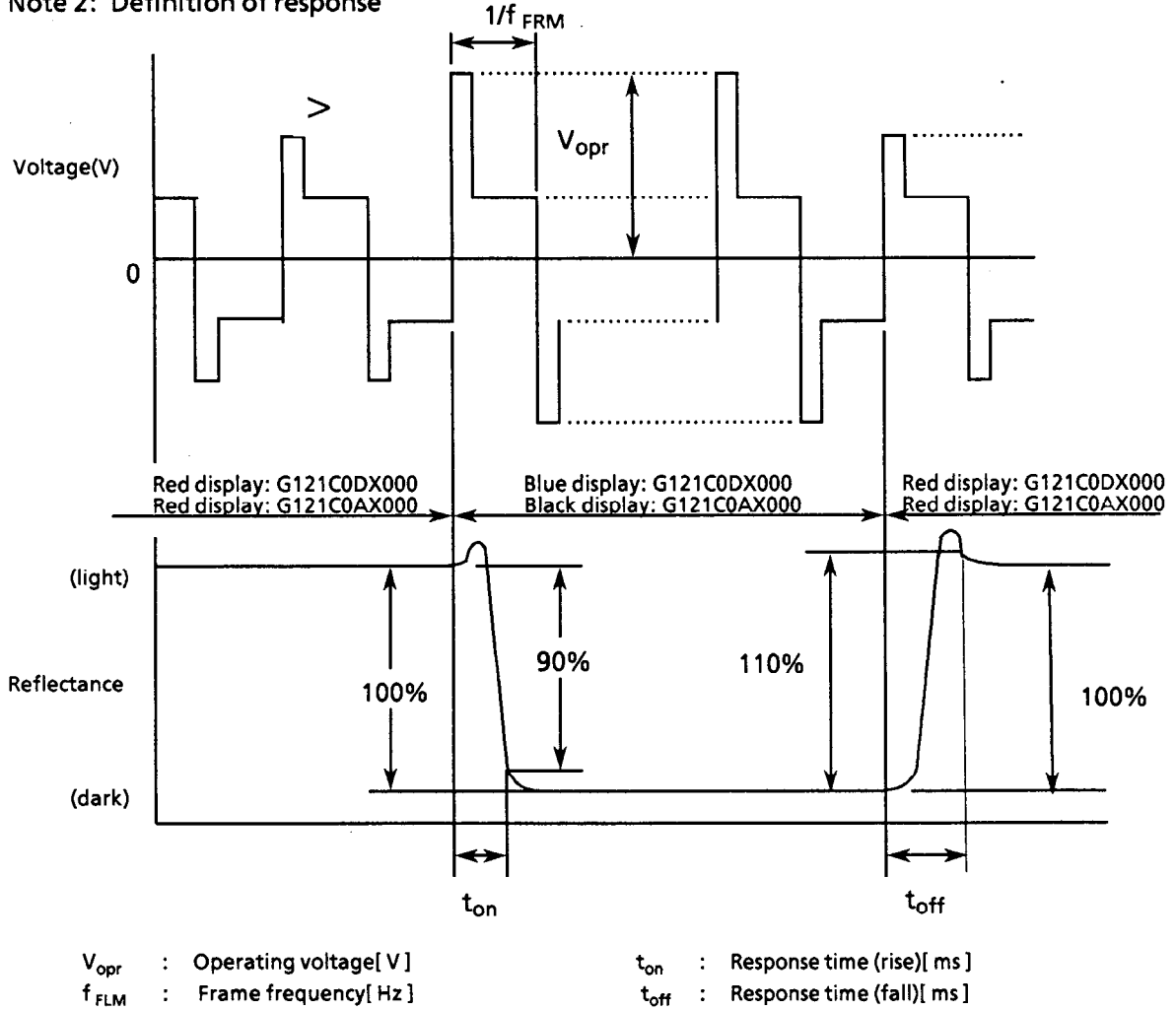

Figure 1 Definition

1.7 LCD Panel Lifetime

Item	Conditions	Standard	Unit
Lifetime*	25°C ± 10°C < 65% RH	> 100,000	hrs

- * Definition of lifetime: the time up to occurrence of any of the following:
- Contrast reduces to 30% of the initial value.
 - Current consumption becomes three times the initial value.
 - Orientation deteriorates significantly.
 - The display malfunctions.

1.8 Dimensions

Unit : mm

General tolerance : ± 0.5 

Figure 2 Dimensions

[I/O terminal functions]

No.	Symbol	Functions
1	V _{DD}	Power supply for logic : + 5 V
2	F _{GND}	Frame ground*1
3	CL2	Display data shift clock
4	$\overline{\text{INH}}$	Display ON/OFF control terminal*2
5	FLM	Frame timing signal
6	CL1	Common-line timing signal
7	V _{SS}	GND : 0 V
8	M	NC
9	D0	Display data input

No.	Symbol	Functions
10	D1	Display data input
11	D2	Display data input
12	D3	Display data input
13	V _{LC}	Power supply for LC drive : - 15 V
14	V _O	Liquid crystal drive voltage adjustment terminal
15	V _{SS}	GND : 0 V
16	NC	OPEN
17	NC	OPEN

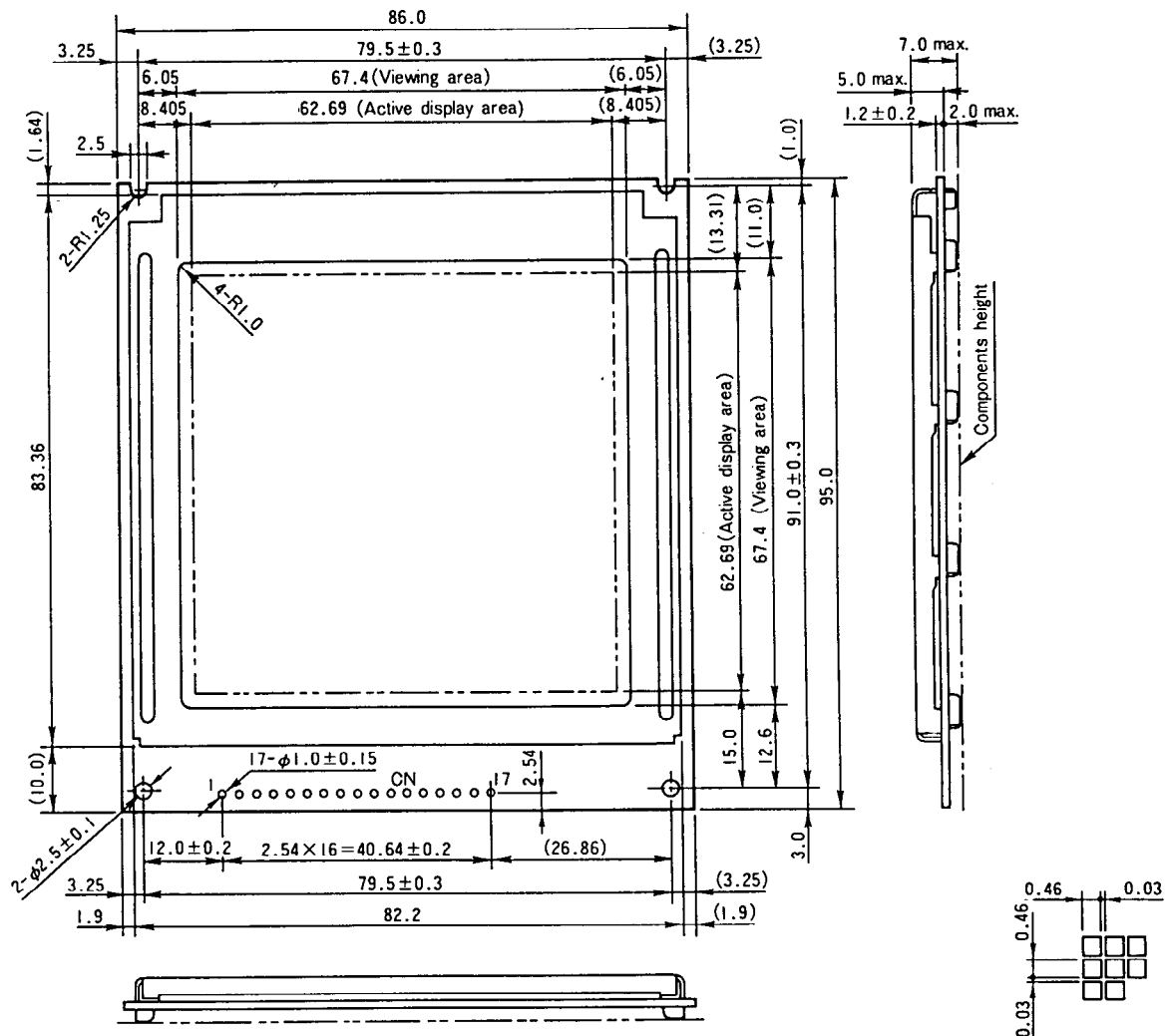
*1 The F_{GND} terminal is connected to the module metal frame. Use this terminal to ground the frame.

*2 The display is ON when $\overline{\text{INH}}$ is H, and OFF when $\overline{\text{INH}} = \text{L}$.

2. CIRCUIT CONFIGURATION

2.1 Liquid Crystal Driving Circuit

The G121C LCD panel drive waveform is shown in Figure 3. Since DC voltage will damage the liquid crystal, AC voltage is applied between the two frames. The signal controlling this is the liquid crystal AC drive control signal M .

Depending on the LCD panels, increasing the liquid crystal AC drive waveform frequency may improve the display quality. The G121C contains a circuit that generates AC drive control signal M' , which has a higher frequency than that of M . The frequency of the M' signal is adjusted according to the LCD panel to provide the best display quality.

The G121C has a 1/128 duty cycle, and the common electrodes are selected within a frame by time division from electrode 1 to electrode 128. This is called line sequential scanning. The voltage level of the segment electrodes determines whether or not the dots at the intersection of the segment electrodes are selected when the common electrode is selected. As shown in Table 1, there are six drive waveform voltage levels, V_a to V_f . The voltage level is determined by the bias value. The voltage between the segment and common electrodes is then applied to the liquid crystal. The selection waveform for SEG_0 - COM_0 and the non-selection waveform for SEG_1 - COM_1 are shown in Figure 3. The size of the effective voltage of the waveform determines whether the liquid crystal under the selected dots is in the selection or non-selection state.

Table 1 Definition of each voltage level

V_a	Common and segment selection level
V_b	Common non-selection level
V_c	Segment non-selection level
V_d	Segment non-selection level
V_e	Common non-selection level
V_f	Common and segment selection level

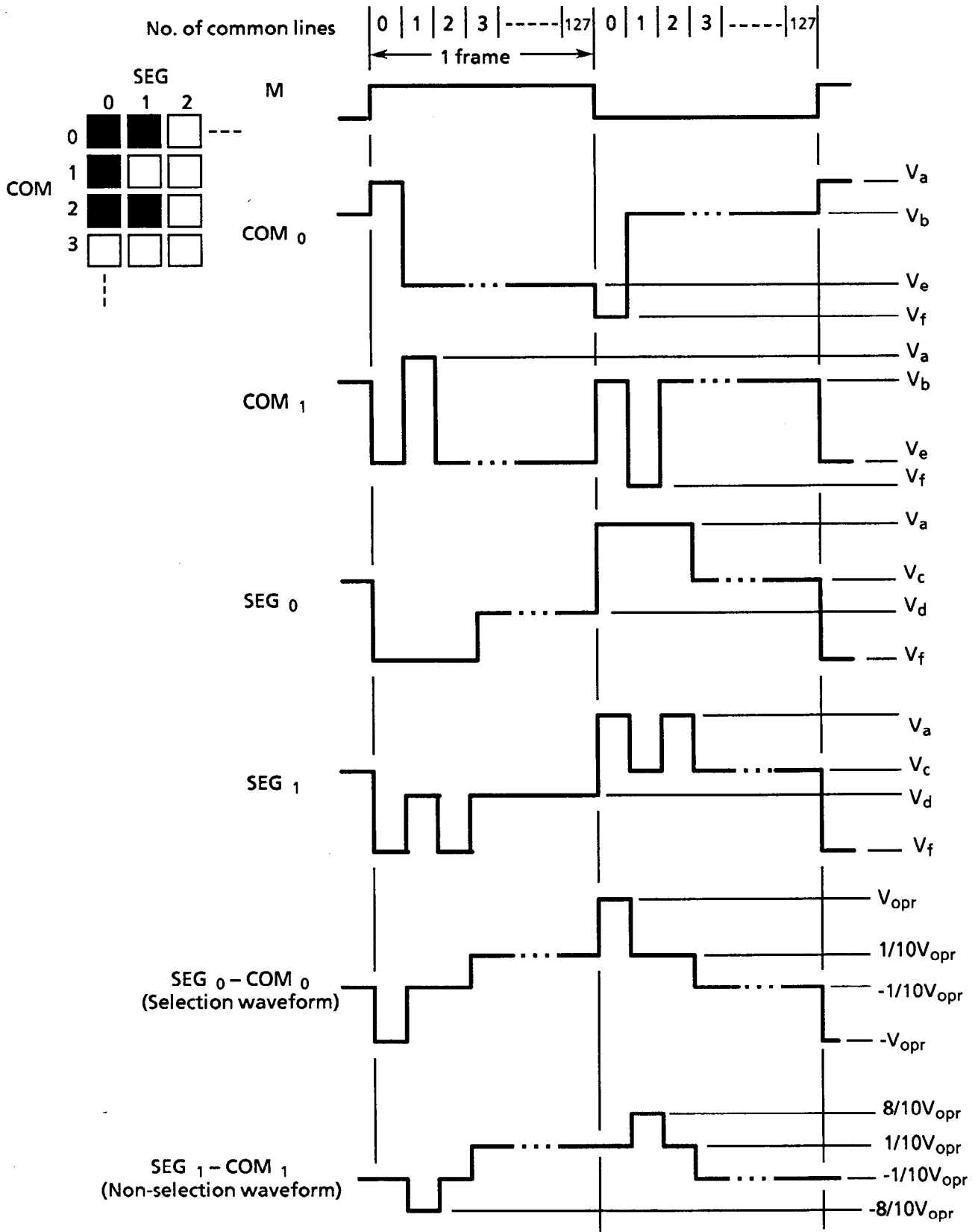

Figure 3 Drive Waveform

G121C displays colors by controlling effective voltage to the LCD.

LCD controllers which support gradation display on a monochrome simple matrix LCD module can control LCD input effective voltage easily.

G121C displays 4 or 3 colors based on the ECB color display method by choosing the gradation levels shown in Table 2 from 9 gradation levels.

The ECB color display method by FRC (Frame Rate Control), which is one of the gradation display methods of the monochrome simple matrix LCD module, is explained below.

Frame rate control, which can generate 9 gradation levels composed of 8 frames in 1 cycle, is shown in Table 2.

Gradation level 0/8 corresponds to the display OFF status in which all of the first frame to the eighth frame are unselected and the effective voltage is lowest.

Gradation level 8/8 corresponds to the display ON status in which all of the first frame to the eighth frame are selected and the effective voltage is highest.

Gradation levels from 1/8 to 7/8 are gray scale levels and increasing the selected level means increasing the effective voltage level.

Table 2 Selected frame numbers vs Gradation levels at 1 cycle (8 frames)

Frame \ Gradation level	1	2	3	4	5	6	7	8
0/8	□	□	□	□	□	□	□	□
1/8	□	□	□	■	□	□	□	□
2/8	□	□	■	□	□	□	■	□
3/8	□	■	□	■	□	□	■	□
4/8	■	□	■	□	■	□	■	□
5/8	■	□	■	□	■	□	■	■
6/8	■	■	□	■	■	■	□	■
7/8	■	■	■	■	■	■	□	■
8/8	■	■	■	■	■	■	■	■

□ : Unselected level, ■ : Selected level

Display colors are selected by the module and level as shown in Table 3.

The correspondence of each gradation level and display color is defined according to the optical design of a ECB LCD panel.

Table 3 Gradation levels vs ECB display color

Gradation level \ Model	0/8	1/8	2/8	3/8	4/8	5/8	6/8	7/8	8/8
G121C0DX000	Red▶	White▶	Green▶	Blue		
G121C0AX000	Red▶	Yellow▶	Black				

See refer to "2.5" for concrete examples of the command settings when using the EPSON LCD controller SED1351F0A with the G121C.

The frame frequency is normally set to 250±10Hz to prevent screen flicker.

2.2 Circuit Configuration

The G121C consists of common drivers, segment drivers, a bias voltage generation circuit, an M' generation circuit and a color tone adjustment circuit. Figure 4 shows the block diagram for the G121C.

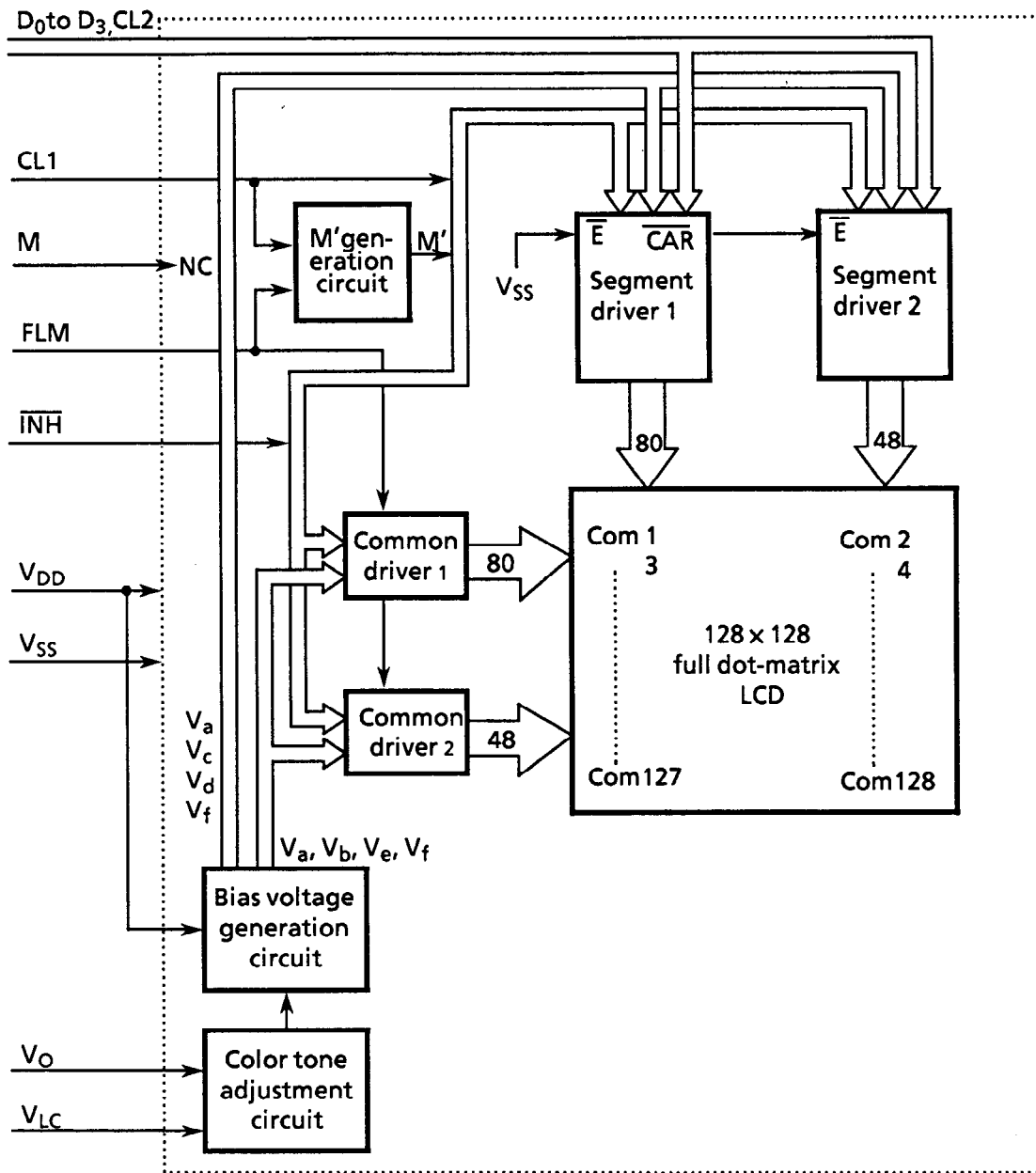

Common drivers : HD66205TF (HITACHI)
 Segment drivers : HD66204TF (HITACHI)

Figure 4 Block Diagram for G121C

(1) Common driver (HITACHI HD66205TF)

A common driver (CD) is a CMOS IC with 80 drive outputs. The G121C has two CDs, whose internal registers are connected to each other. They operate as follows.

Input frame timing signal (FLM) is taken into the internal shift register by the falling edge trigger of the common-line timing signal (CL1), and sequentially shifted. After 128-CL1 input, the next FLM is input and the same operation is repeated. As shown in Table 2, the common output is selected according to the shift register contents and the internally-generated liquid crystal AC drive control signal (M') in the drive circuit, and the common drive waveform are formed.

Table 4 Common Output

INH	Shift register content	M'	CD output	Display
H	H	H	V_a	ON
		L	V_f	
	L	H	V_e	
		L	V_b	
L	X	X	V_a	OFF

x: Invalid

The CD output is controlled by the $\overline{\text{INH}}$ signal; when the $\overline{\text{INH}}$ signal is low, the CD output is V_a , irrespective of the shift register contents or the M' signal.

(2) Segment driver (HITACHI HD66204TF)

A segment driver (SD) is a CMOS IC with 80 drive outputs. The G121C has two SDs, which operate as follows.

Input 4-bit data is sequentially taken into the internal register by the falling edge trigger of the display data shift clock (CL2). The SDs have chip enable functions. After 80 bits of data are taken into SD1, the next bit of data is automatically taken into SD2. Since G121C has two SDs, 128 bits of data can be taken. The display data taken into the internal register are latched by the falling edge trigger of CL1. The segment output is selected according to this display data and M' in the drive circuit, and the segment drive waveform is formed as shown in the Table 3.

Table 5 Segment Output

INH	Display data	M'	SD output	Display
H	H	H	V_f	ON
		L	V_a	
	L	H	V_d	
		L	V_c	
L	X	X	V_a	OFF

x: don't care

The segment output is controlled by the $\overline{\text{INH}}$ signal. When the $\overline{\text{INH}}$ signal is low, V_a is output to the segment, irrespective of the display data and of the M' signal.

Therefore, by bringing the INH signal to low, V_a is output both to the common and to the segment electrodes, making the voltage applied to the liquid crystal zero, and the display goes off.

The relationship between the display data and display screen is shown below..

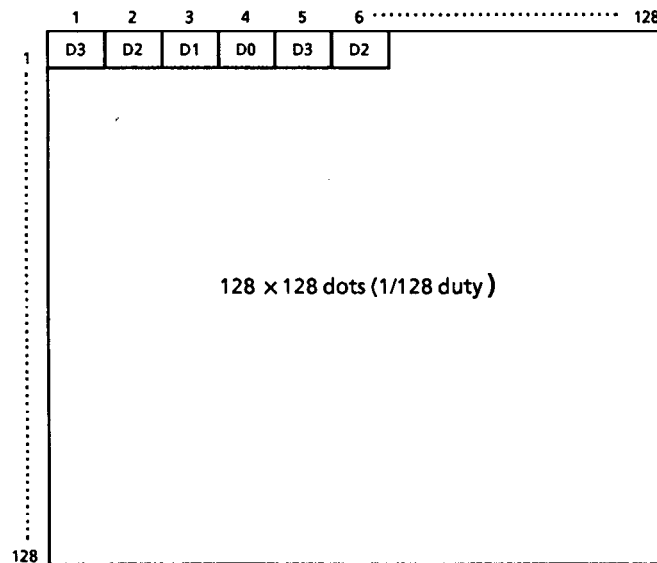

Figure 5 Relationship between the Display Data and Display Screen

(3) Color tone adjustment circuit

Display color tone and viewing angle are affected by changes in the liquid crystal operating voltage (V_{opr}). As shown in Figure 6, external V_{LC} is supplied to the operational amplifier and V_{opr} (V_a to V_f) is generated and applied to the LCD panel.

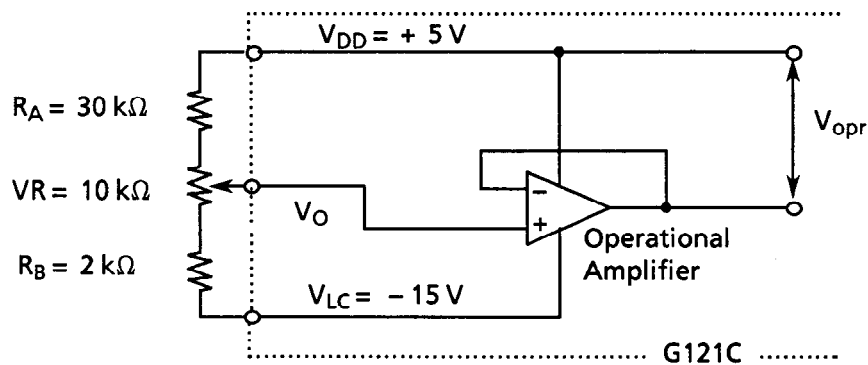

Figure 6 Color tone Adjustment Circuit

(4) Bias voltage generation circuit

Six voltage levels, V_a to V_f , are applied to the common and segment drivers. The voltage is generated through operational amplifiers by resistance division from the liquid crystal operating voltage (V_{opr}). Here, an operational amplifier is used as a voltage follower.

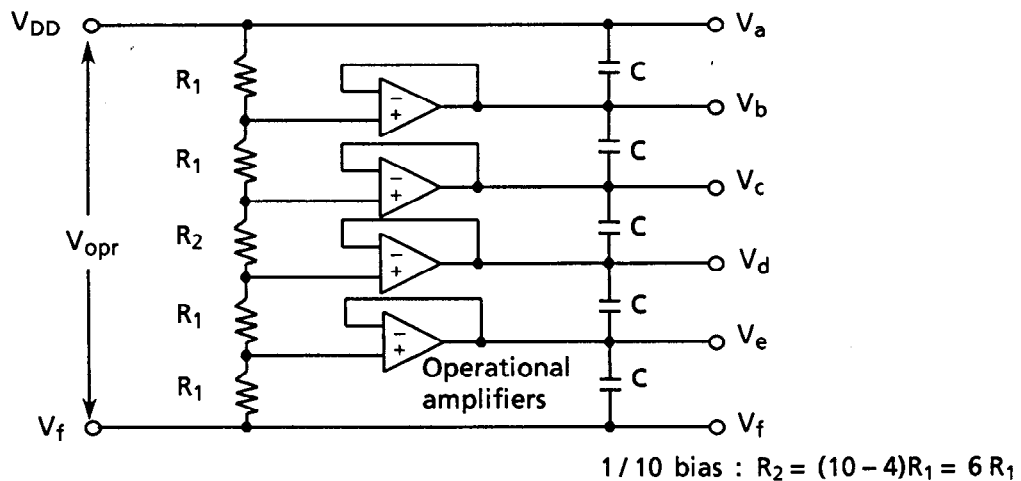

Figure 7 Bias Voltage Generation Circuit

(5) M' generation circuit

As Figure 8 shows, the M' generation circuit performs an XOR on the common-line timing signal (CL1) (on which A time division is performed) and the frame timing signal (FLM) (on which B time division is performed), and outputs liquid crystal AC drive control signal M' . Values A and B are set according to the LCD panel so that the best display quality can be obtained and the drive voltage can be changed.

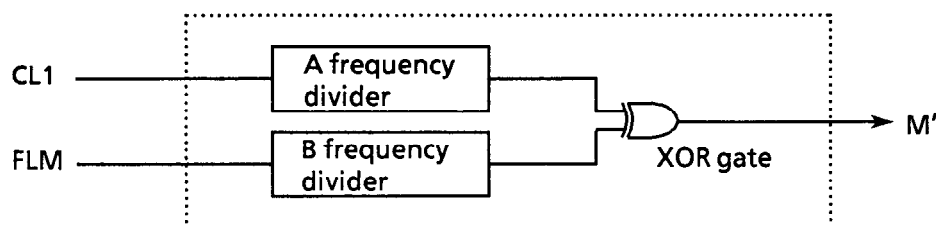

Figure 8 M' Generation Circuit

2.3 Timing Characteristics

2.3.1 Power ON/OFF and Signal Input Timing

Power ON/OFF and signal input should be performed according to the timing shown in the figure below in order not to damage the LCD driving circuit and the LCD panel.

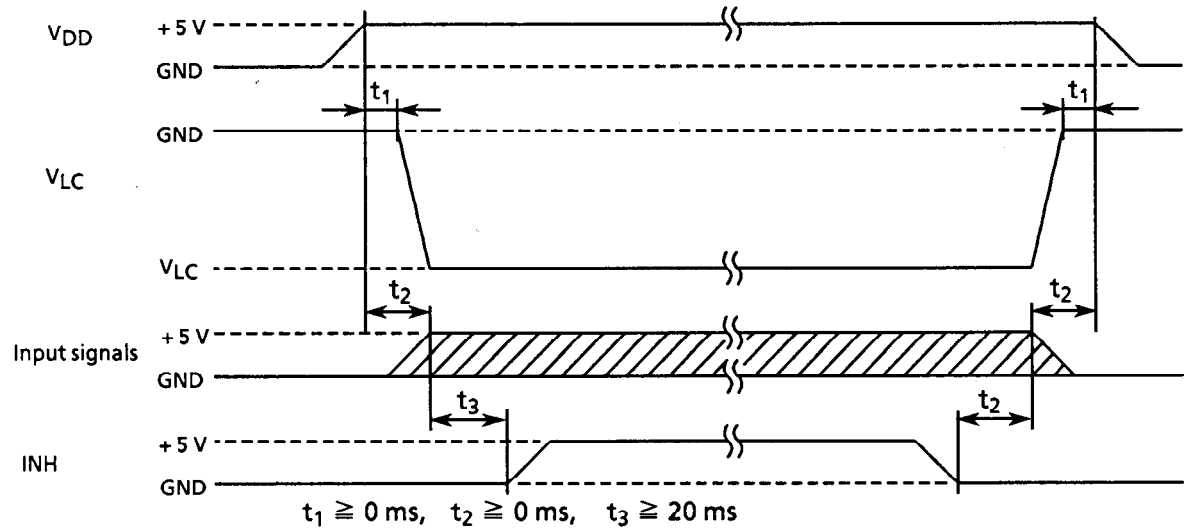

Figure 9 Power ON/OFF and Signal Input Timing

2.3.2 Timing Characteristics

$T_a = 0^\circ\text{C to } 60^\circ\text{C}$ $V_{DD} = 5.0\text{V} \pm 5\%$ $V_{SS} = 0\text{V}$

Item	Symbol	Min.	Typ.	Max.	Unit
FLM cycle time	t_{CLFM}	3.8	4.0	4.2	ms
CL1 cycle time	t_{CCL1}	10	—	—	μs
CL1 high level width	t_{WCL1H}	50	—	—	ns
CL1 low level width	t_{WCL1L}	1	—	—	μs
CL1 rise time	t_{RCL1}	—	—	30	ns
CL1 fall time	t_{FCL1}	—	—	30	ns
FLM setup time	t_{FLMS}	100	—	—	ns
FLM hold time	t_{FLMH}	100	—	—	ns
Allowable M delay time	t_{DM}	—	—	300	ns
CL2 cycle time	t_{CCL2}	125	—	—	ns
CL2 high level width	t_{WCL2H}	45	—	—	ns
CL2 low level width	t_{WCL2L}	45	—	—	ns
CL2 rise time	t_{RCL2}	—	—	50*	ns
CL2 fall time	t_{FCL2}	—	—	50*	ns
Data setup time	t_{DS}	20	—	—	ns
Data hold time	t_{DH}	20	—	—	ns
CL2 rise to CL1 rise	t_{LD}	—	—	—	ns
CL2 fall to CL1 fall	t_{SL}	80	—	—	ns
CL1 rise to CL2 rise	t_{LS}	—	—	—	ns
CL1 fall to CL2 fall	t_{LH}	80	—	—	ns

$$* t_{\text{RCL2}}, t_{\text{FCL2}} < \frac{t_{\text{CCL2}} - t_{\text{WCL2H}} - t_{\text{WCL2L}}}{2}$$

Timing Chart 1: Timing of Signal Input Into Common Driver

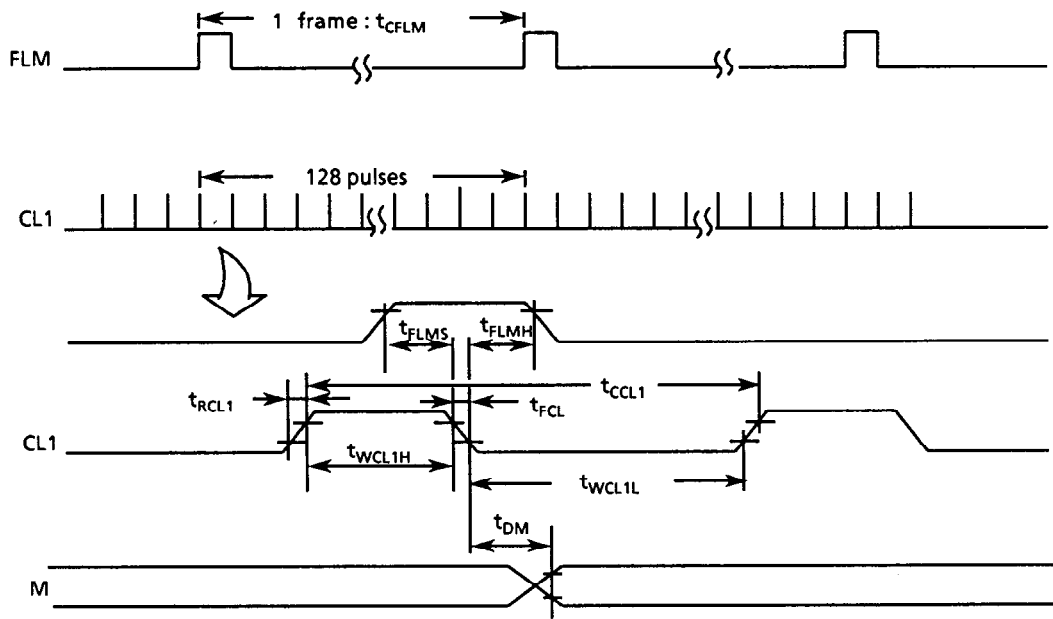

Figure 10

Timing Chart 2: Timing of Signal Input Into Segment Driver

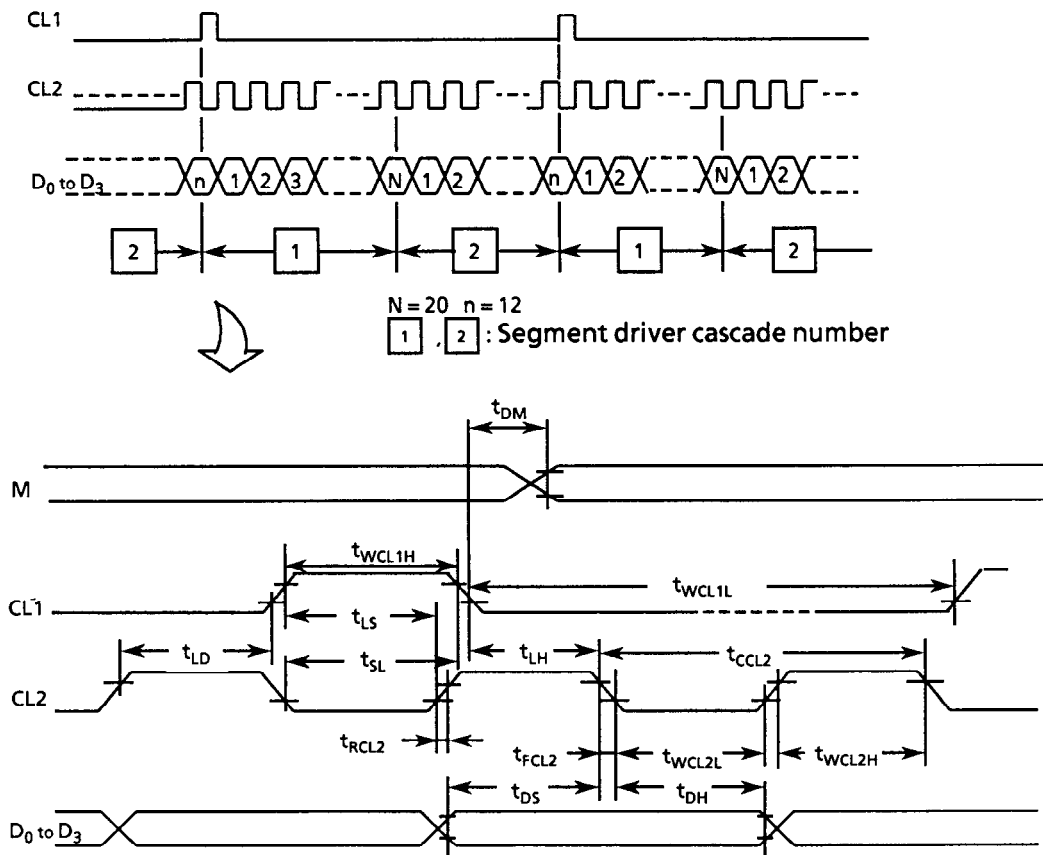

Figure 11

2.4 Interface Circuit

The G121C0DX000 and the G121C0AX000 are controlled by the MPU circuit, whose interface is easily set up when the LCD controller is used. The LCD controller has basic functions such as receiving information related to the display from the MPU circuit, sending display timing signals and display data to the LCD module, as well as other functions such as cursor display.

The G121C must use an LCD controller capable of to the following:

- Control of a full dot-matrix LCD module
- Gradiational display by frame rate control can be executed
(8 or more gradation display capability is recommended for the best color display.)
- Data transfer to the LCD module in 4-bit parallel
- Display by 1/128 duty
- An adjustment of the frame frequency for a flickerless screen

The following section gives examples of interfaces using the EPSON SED1351F0A controllers.

2.4.1 Example of interface with SED1351F0A

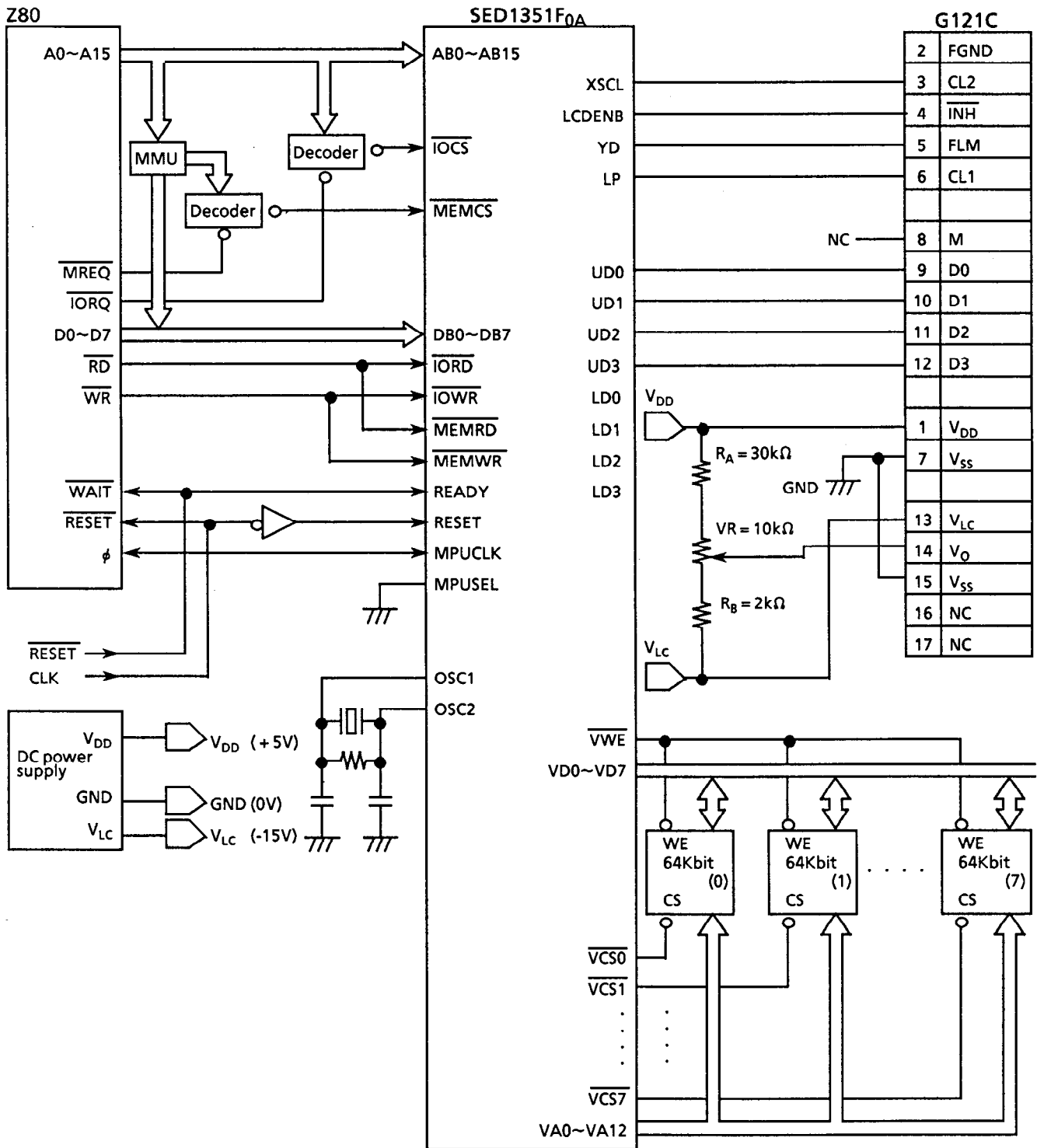

Figure 12 G121C0DX000/G121C0AX000 Interface with SED1351F0A

Features of the SED1351F0A:

- Interface with 80-series MPU possible.
- 4 gradational displays possible. 9 gradation levels selectable.
- Scrolling and paging in length.
- CMOS process.
- Power supply voltage $5V \pm 10\%$.

2.5 Examples of command setting to SED1351F0A

2.5.1 G121C0DX000

(1) Setting values

Command No.	Setting value	Register function
R1	89H	Mode setting DISPOFF
R1	8BH	DISPON
R2	1FH	Character numbers in horizontal display
R3	1DH	HD (Horizontal Drive) pulse width
R4	7FH	Number of vertical lines
R5	00H	
R6	00H	Start address for the first screen
R7	00H	
R8	00H	Start address for the second screen
R9	00H	
R10	7FH	Vertical line numbers of the first screen
R11	00H	
R13	00H	Address pitch adjustment
R14	49H	Gradiation converting code: GS1
R15	77H	Gradiation converting code: GS2

The clock to OSC1 pin: 4 MHz

(2) Explanation of GS1 and GS2 setting

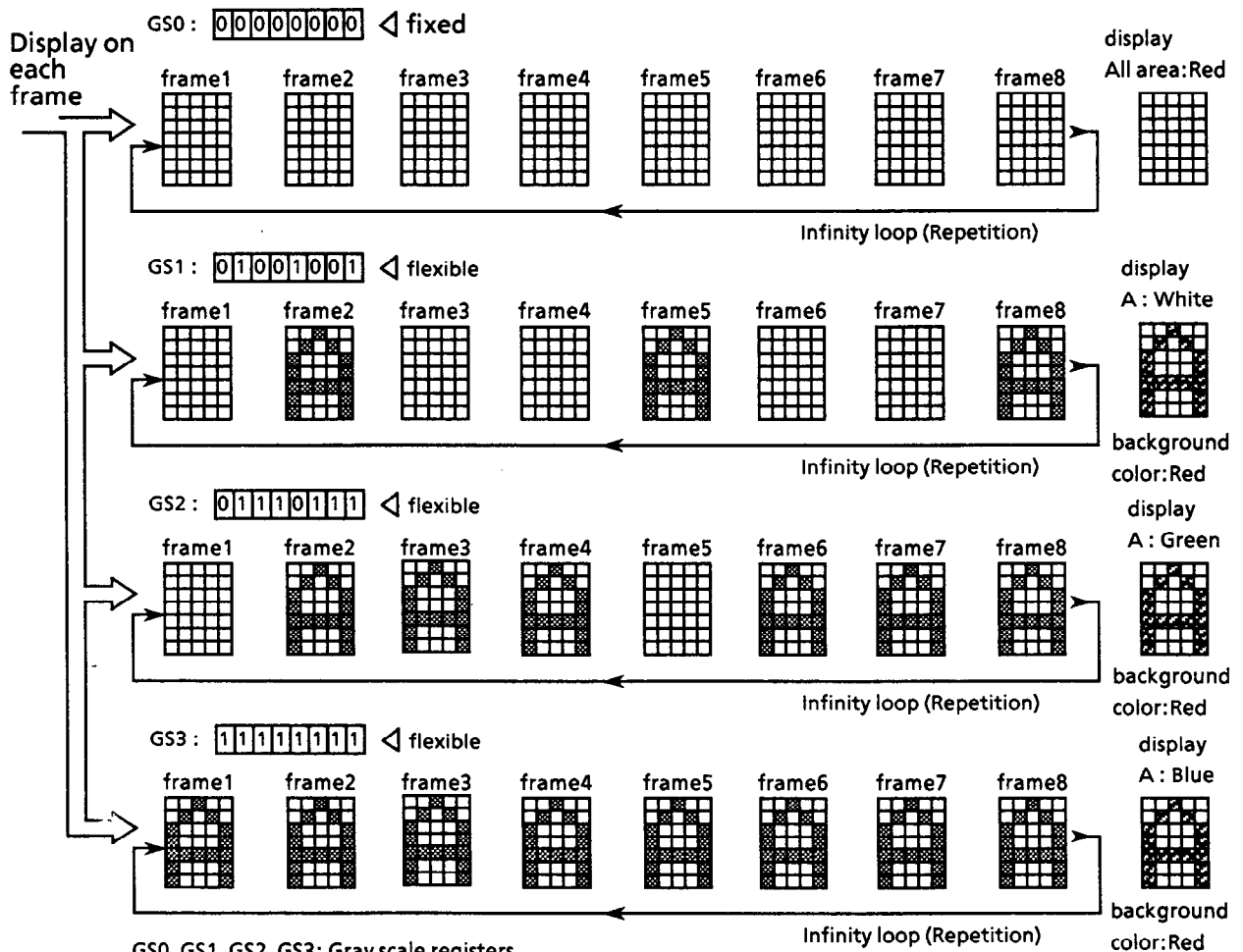

GS0, GS1, GS2, GS3: Gray scale registers.
A gradation cycle with the frame rate control is composed of 8 frames.

2.5.2 G121C0AX000

(1) Setting values

Command No.	Setting value	Register function
R1	89H	Mode setting DISPOFF
R1	8BH	DISPON
R2	1FH	Character numbers in horizontal display
R3	1DH	HD (Horizontal Drive) pulse width
R4	7FH	Number of vertical lines
R5	00H	
R6	00H	Start address for the first screen
R7	00H	
R8	00H	Start address for the second screen
R9	00H	
R10	7FH	Vertical line numbers of the first screen
R11	00H	
R13	00H	Address pitch adjustment
R14	49H	Gradiation converting code: GS1
R15	77H	Gradiation converting code: GS2

The clock to OSC1 pin: 4 MHz

(2) Explanation of GS1 and GS2 setting

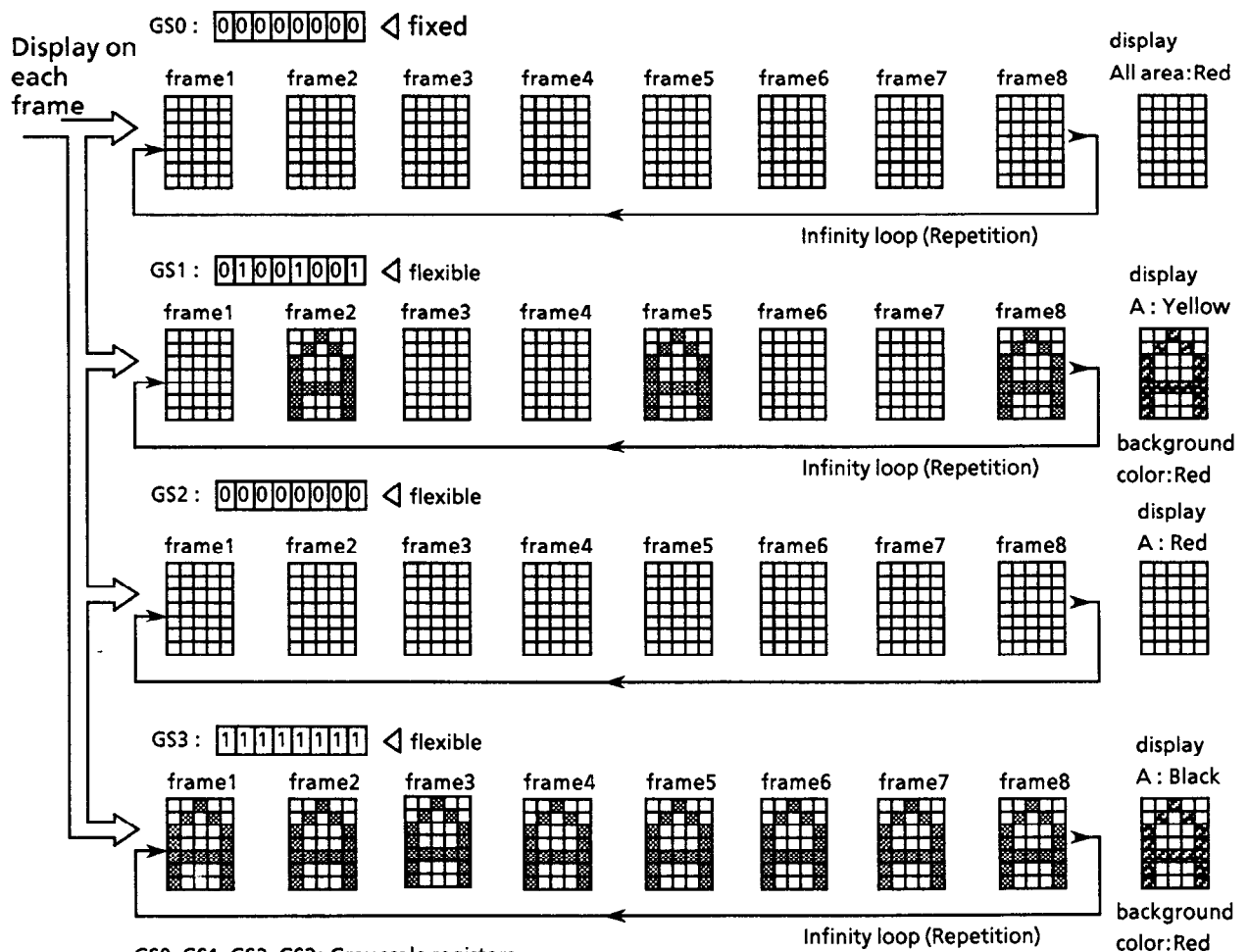

3. PRECAUTIONS

Safety

- First aid in case of damage to the LCD panel:
 - In getting in eyes: Clean eyes in clear running water at least 15 minutes without rubbing.
 - In attaching in skin: Wash it off thoroughly with soap and water after flowing out fragments of broken glass in running water.
 - In swallowing: Clean up inside of mouth after spitting out with giving a large quantity water. Receive a treatment by doctors immediately.
- Beware of glass fragments when touching the edge of the glass.

Handling

- Avoid static electricity, as it will damage the CMOS LSI.
- The LCD panel is made of plate glass. Do not hit, crush, or bend it.
- Do not remove the panel or frame from the module.
- The polarizer of the display is very fragile. Handle it with care.

Mounting and design

- Mount the module using the specified mounting parts and holes.
- Connecting a $10\mu\text{F}$ capacitor between power supply pins is recommended to remove the noise from the power input.
- To protect the module against external pressure, place a transparent plate (e.g., acrylic or glass) on the module, leaving a small gap between the display surface and transparent plate.

☆Example

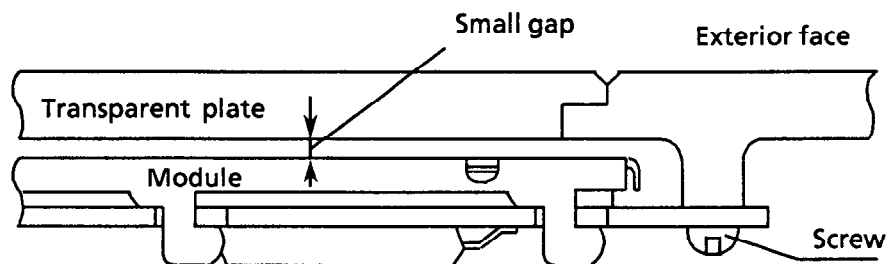

- No signal should be input in non-power voltage input.
- Do not use the module in a condensing environment to prevent the wires of the transparent electrodes from breaking.

Storage

- Store the module in a dark place, where the temperature is $25\text{ }^{\circ}\text{C} \pm 10\text{ }^{\circ}\text{C}$ and the relative humidity is below 65%.
- Do not store the module near organic solvents or corrosive gases.
- Keep the module (including accessories) safe from vibration, mechanical shock and external pressure.

Cleaning

- Do not wipe the polarizer with a dry cloth, as it may scratch the surface.
- Wipe the module gently with a soft cloth soaked with a petroleum benzine.
- Do not use ketonic (ketone) solvents (ketone and acetone) or aromatic solvents (toluene and xylene), as they may damage the polarizer.

Index

-B-

Bias value	7
Bias voltage generation circuit	10, 13
Block diagram	10

-C-

Chip enable function	11
Cleaning	20
Common drive waveform	11
Common driver	10, 11
Contrast	1, 3, 4, 5
Current consumption	2, 5

-D-

Definition of contrast	5
Definition of response time	5
Display data input	6
Display data shift clock	2, 6, 11
Display ON/OFF control terminal	6
Drive waveform	7

-E-

Effective voltage	3, 4, 7, 9
-------------------------	------------

-F-

Flicker	9
Frame frequency	2, 5, 9, 16
Frame ground	6

-I-

I/O terminal functions	6
Input voltage	2
Interface	16, 17

-L-

LCD controller	2, 9, 16
Liquid crystal drive voltage adjustment terminal	6
Liquid crystal operating voltage	12, 13

-M-

M' generation circuit	10, 13
-----------------------------	--------

-N-

Non-selection waveform	7, 8
------------------------------	------

-O-

Operating temperature	2, 3, 4
Operational amplifier	12, 13

-P-

Power supply voltage	2, 17
----------------------------	-------

-R-

Resistance division	13
Response time (fall)	5
Response time (rise)	5

-S-

Segment drive waveform	11
Segment driver	10, 11, 15
Selection waveform	7, 8
Storage	20
Storage humidity	2
Storage temperature	2

-V-

Viewing angle	1, 12
---------------------	-------

Seiko Instruments Inc.

Head Office

Components Overseas Marketing & Sales Department
1-8, Nakase, Mihama-ku, Chiba-shi, Chiba 261, Japan
Phone: 043-211-1213 FAX: 043-211-8035

Seiko Instruments U.S.A. Inc.

Electronic Components Division

2990 W. Lomita Blvd., Torrance Calif. 90505, USA Phone: 310-517-7770 FAX: 310-517-7792

Seiko Instruments GmbH

Siemensstrasse 9b, 63263 Neu-Isenburg, Germany Phone: 49-6102-297-0 FAX: 49-6102-297-222

Seiko Instruments (H. K.) Ltd. Sales Division

4-5/F, Wylar Centre 2, 200 Tai Lin Pai Road, Kwai Chung, N.T., Kowloon, Hong Kong
Phone: 852-4218611 FAX: 852-4805479

Seiko Instruments Taiwan Inc.

5F-1 No. 99, SEC.2, Chung Shan N. Rd., Taipei 104, Taiwan, R.O.C.
Phone: 886-2-563-5001 FAX: 886-2-521-9519