

**Doc. Number :**

- Tentative Specification
- Preliminary Specification
- Approval Specification

**MODEL NO.: G156HCE**  
**SUFFIX: E01**

<b>Customer:</b>	
<b>APPROVED BY</b>	<b>SIGNATURE</b>
<u>Name / Title</u> _____	_____
Note	
<hr/> Please return 1 copy for your confirmation with your signature and comments.	

Approved By	Checked By	Prepared By

## CONTENTS

<b>1. GENERAL DESCRIPTION .....</b>	<b>5</b>
1.1 OVERVIEW .....	5
1.2 GENERAL SPECIFICATIONS .....	5
<b>2. MECHANICAL SPECIFICATIONS .....</b>	<b>5</b>
<b>3. ABSOLUTE MAXIMUM RATINGS .....</b>	<b>6</b>
3.1 ABSOLUTE RATINGS OF ENVIRONMENT .....	6
3.2 ELECTRICAL ABSOLUTE RATINGS .....	6
3.2.1 TFT LCD MODULE .....	6
3.2.2 BACKLIGHT CONVERTER.....	6
<b>4. ELECTRICAL SPECIFICATIONS .....</b>	<b>7</b>
4.1 FUNCTION BLOCK DIAGRAM .....	7
4.2. INTERFACE CONNECTIONS .....	8
4.3 ELECTRICAL CHARACTERISTICS .....	9
4.3.1 LCD ELETRONICS SPECIFICATION .....	9
4.3.2 Vcc Power Dip Condition.....	錯誤! 尙未定義書籤。
4.3.3 BACKLIGHT UNIT.....	11
4.3.4 BACKLIGHT PIN ASSIGNMENT.....	11
4.4 LVDS INPUT SIGNAL SPECIFICATIONS .....	12
4.4.1 LVDS DATA MAPPING TABLE .....	錯誤! 尙未定義書籤。
4.4.2 COLOR DATA INPUT ASSIGNMENT.....	12
4.5 DISPLAY TIMING SPECIFICATIONS .....	14
4.6 POWER ON/OFF SEQUENCE.....	15
<b>5. OPTICAL CHARACTERISTICS .....</b>	<b>17</b>
5.1 TEST CONDITIONS .....	17
5.2 OPTICAL SPECIFICATIONS .....	17
<b>6. RELIABILITY TEST ITEM .....</b>	<b>20</b>
<b>7. PACKING .....</b>	<b>21</b>
<b>8. MODULE LABEL.....</b>	<b>23</b>
<b>9. PRECAUTIONS .....</b>	<b>24</b>
9.1 ASSEMBLY AND HANDLING PRECAUTIONS .....	24
9.2 STORAGE PRECAUTIONS .....	24
9.3 OPERATION PRECAUTIONS .....	24
9.4 SAFETY PRECAUTIONS .....	24
9.5 SAFETY STANDARDS .....	25
9.6 OTHER .....	25

10. Outline Drawing.....26

## **REVISION HISTORY**

Version	Date	Page	Description
1.0	Jan.06, 2017	All	Spec Ver. 1.0 was first issued.

## 1. GENERAL DESCRIPTION

### 1.1 OVERVIEW

G156HCE-E01 is a 15.6" TFT Liquid Crystal Display module with LED Backlight unit and 40 pins eDP interface. This module supports 1920 x 1080 FHD AAS mode and can display 262,144 colors. The LED driving device for Backlight is built in PCBA.

### 1.2 GENERAL SPECIFICATIONS

Item	Specification	Unit	Note
Screen Size	15.6" real diagonal		
Driver Element	a-si TFT active matrix	-	-
Pixel Number	1920 x R.G.B. x 1080	pixel	-
Pixel Pitch	0.17925 (H) x 0.17925 (V)	mm	-
Pixel Arrangement	RGB vertical stripe	-	-
Display Colors	16.7M	color	-
Transmissive Mode	Normally Black	-	-
Surface Treatment	Hard coating (3H), Anti-Glare	-	-
Luminance, White	450	Cd/m2	
Color Gamut	72 % of NTSC(Typ.)	-	-
Power Consumption	12.1	W	Max

## 2. MECHANICAL SPECIFICATIONS

Item	Min.	Typ.	Max.	Unit	Note	
Module Size	Horizontal (H)	363.30	363.80	364.30	mm	
	Vertical (V)	215.48	215.98	216.48	mm	
	Thickness (T)	9.00	9.30	9.60	mm	
Bezel Area	Horizontal	347.03	347.53	348.03	mm	
	Vertical	196.34	196.84	197.34	mm	
Active Area	Horizontal	-	344.16	-	mm	
	Vertical	-	193.59	-	mm	
Weight	-	1100	1135	g		

## 3. ABSOLUTE MAXIMUM RATINGS

### 3.1 ABSOLUTE RATINGS OF ENVIRONMENT

Item	Symbol	Value		Unit	Note
		Min.	Max.		
Storage Temperature	TST	-20	60	°C	(1)
Operating Ambient Temperature	TOP	0	50	°C	(1), (2)

Note (1)

(a) 90 %RH Max. ( $T_a < 40\text{ °C}$ ).

(b) Wet-bulb temperature should be  $39\text{ °C}$  Max. ( $T_a < 40\text{ °C}$ ).

(c) No condensation.

Note (2) The temperature of panel surface should be  $0\text{ °C}$  min. and  $60\text{ °C}$  max.

### 3.2 ELECTRICAL ABSOLUTE RATINGS

#### 3.2.1 TFT LCD MODULE

Item	Symbol	Value		Unit	Note
		Min.	Max.		
Power Supply Voltage	V <sub>CC</sub>	-0.3	4	V	(1)
Logic Input Voltage	V <sub>IN</sub>	-0.3	V <sub>CCS</sub> +0.3	V	

Note (1) Stresses beyond those listed in above “ELECTRICAL ABSOLUTE RATINGS” may cause permanent damage to the device. Normal operation should be restricted to the conditions

described in “ELECTRICAL CHARACTERISTICS” .

#### 3.2.2 BACKLIGHT CONVERTER

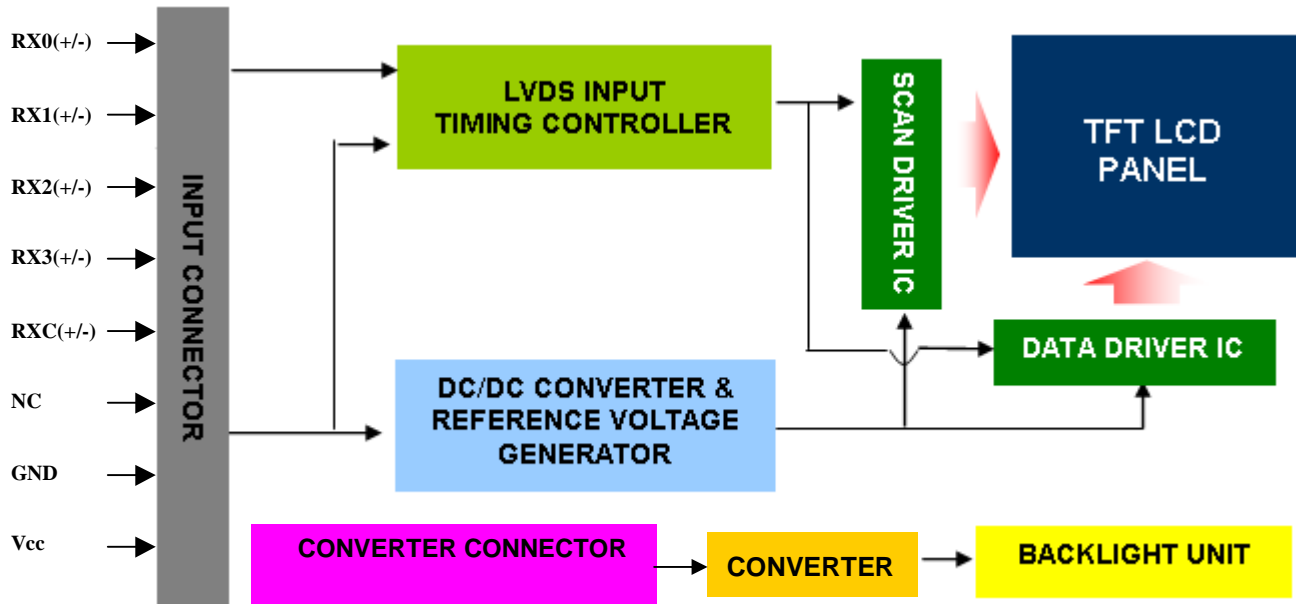
Item	Symbol	Value			Unit	Note
		Min.	Typ	Max.		
Converter Voltage	LED_V <sub>in</sub>	0	12	18	V	(1), (2) Duty=100%
Enable Voltage	LED_EN	0	3.3	7	V	
Backlight Adjust	LED_PWM	0	3.3	7	V	(1), (2) Pulse Width $\leq 10\text{msec.}$ and Duty $\leq 10\%$

Note (1) Permanent damage to the device may occur if maximum values are exceeded. Function operation should be restricted to the conditions described under Normal Operating Conditions.

Note (2) Specified values are for input pin of LED light bar at  $T_a = 25 \pm 2\text{ °C}$  (Refer to 4.3.3 and 4.3.4 for further information).

## 4. ELECTRICAL SPECIFICATIONS

### 4.1 FUNCTION BLOCK DIAGRAM



## 4.2. INTERFACE CONNECTIONS

### PIN ASSIGNMENT

Pin	Name	Description
1	NC	Reverse for INNOLUX test only.
2	H_GND	High Speed Ground.
3	Lane1_N	Comp Signal Lane1.
4	Lane1_P	True Signal Link Lane1.
5	H_GND	High Speed Ground.
6	Lane0_N	Comp Signal Lane0.
7	Lane0_P	True Signal Link Lane0.
8	H_GND	High Speed Ground.
9	AUX_CH_P	True Signal Auxiliary Ch.
10	AUX_CH_N	Comp Signal Auxiliary Ch
11	H_GND	High Speed Ground.
12	LCD_Vcc	LCD logic and Driver power
13	LCD_Vcc	LCD logic and Driver power
14	LCD_Self_Test or NC	LCD Panel Self Test Enable(Optional)
15	LCD_GND	LCD logic and Driver ground
16	LCD_GND	LCD logic and Driver ground
17	HPD-	HPD Signal pin
18	BL_GND	Backlight_ ground
19	BL_GND	Backlight_ ground
20	BL_GND	Backlight_ ground
21	BL_GND	Backlight_ ground
22	BL_Enable	Backlight ON / OFF
23	BL PWM DIM	System PWM Signal Input
24	NC	Reverse for INNOLUX test only.
25	NC	Reverse for INNOLUX test only.
26	BL PWR	Backlight Power (5V~21V)
27	BL PWR	Backlight Power (5V~21V)
28	BL PWR	Backlight Power (5V~21V)
29	BL PWR	Backlight Power (5V~21V)
30	NC	No Connect (Reserved for CM)
31	NC	No Connect (Reserved)
32	NC	No Connect (Reserved)
33	NC	No Connect (Reserved)
34	NC	No Connect (Reserved)
35	NC	No Connect (Reserved)
36	NC	No Connect (Reserved)
37	NC	No Connect (Reserved)
38	NC	No Connect (Reserved)
39	NC	No Connect (Reserved)
40	NC	No Connect (Reserved)

Note (1) Connector Part No.: xxxxxxx

Note (2) The first pixel is odd.

Note (3) Input signal of even and odd clock should be the same timing.



## 4.3 ELECTRICAL CHARACTERISTICS

### 4.3.1 LCD ELETRONICS SPECIFICATION

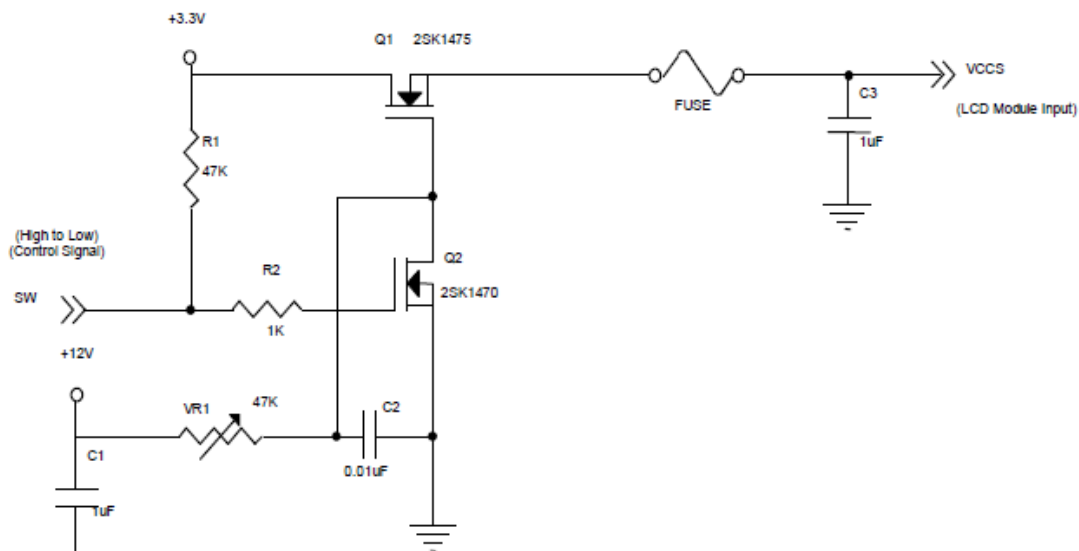
Parameter	Symbol	Value			Unit	Note
		Min.	Typ.	Max.		
Power Supply Voltage	V <sub>CC</sub>	3.0	3.3	3.6	V	(1)
Ripple Voltage	V <sub>RP</sub>	-	50-		mV	(1)
Rush Current	I <sub>RUSH</sub>	-	-	1.5	A	(1),(2)
Power Supply Current	Mosaic	-	230	260	mA	(3)a
	Black	-	210	240	mA	(3)
HPD	High Level	2.25-		2.75	V	(5)
	Low Level	0		0.4	V	(5)
HPD Impedance	R <sub>HPD</sub>	30K			ohm	(5)

Note (1) The ambient temperature is  $T_a = 25 \pm 2$  °C.

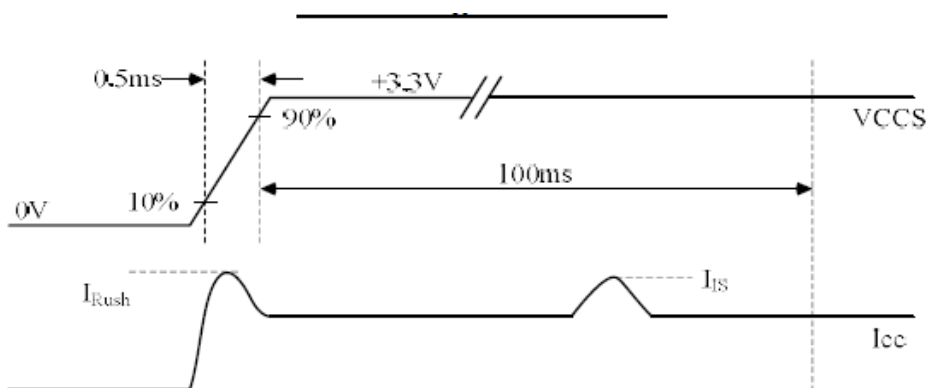
Note (2) I<sub>RUSH</sub>: the maximum current when V<sub>CCS</sub> is rising

I<sub>IS</sub>: the maximum current of the first 100ms after power-on

Measurement Conditions: Shown as the following figure. Test pattern: black.

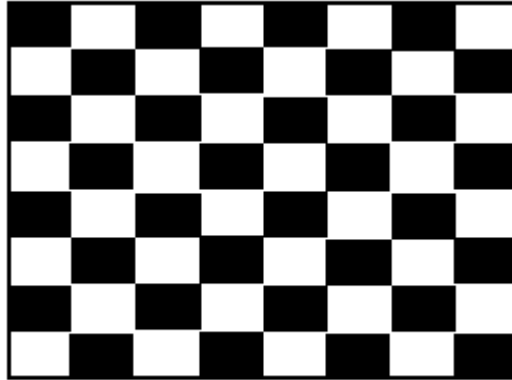


**VCCS rising time is 0.5ms**



Note (3) The specified power supply current is under the conditions at  $V_{CCS} = 3.3\text{ V}$ ,  $T_a = 25 \pm 2\text{ }^\circ\text{C}$ , DC Current and  $f_v = 60\text{ Hz}$ , whereas a power dissipation check pattern below is displayed.

a. Mosaic Pattern



Active Area

Note (4) The specified signals have equivalent impedances pull down to ground in the LCD module respectively. Customers should keep the input signal level requirement with the load of LCD module. Please refer to Note (4) of 4.3.2 LED CONVERTER SPECIFICATION to obtain more information.

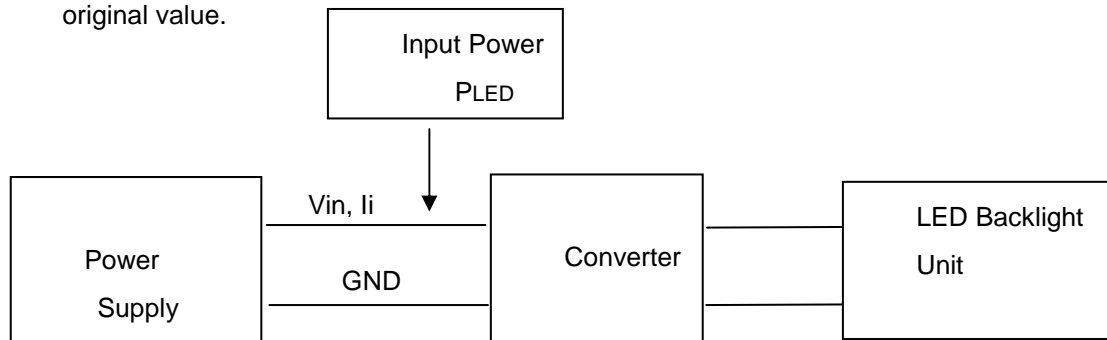
Note (5) When a source detects a low-going HPD pulse, it must be regarded as a HPD event. Thus, the source must read the link / sink status field or receiver capability field of the DPCD and take corrective action.

## 4.3.2 BACKLIGHT UNIT

Parameter	Symbol	Value			Unit	Note	
		Min.	Typ.	Max.			
Converter Power Supply Voltage	LED_Vin	10.8	12.0	13.2	V		
Converter Power Supply Current	li	0.8	1.0	1.2	A	@LED_Vin= 12V Duty=100%	
Power Consumption	P <sub>LED</sub>			10.5	W	@ LED_Vin = 12V Duty=100%	
EN Control Level	Backlight on	LED_EN	2.0	3.3	5.0	V	
	Backlight off		0	0	0.8		
PWM Control Level	PWM High Level	LED_PWM	2.0	3.3	5.0	V	
	PWM Low Level		0	0	0.15		
PWM Control Duty Ratio			10	--	100	%	
PWM Control Frequency		f <sub>PWM</sub>	190	200	20k	Hz	
LED Life Time		L <sub>L</sub>	50,000			Hrs	(2)

Note (1) LED light bar input voltage and current are measured by utilizing a true RMS multimeter as shown below:

Note (2) The lifetime of LED is defined as the time when LED packages continue to operate under the conditions at  $T_a = 25 \pm 2 \text{ }^\circ\text{C}$  and  $I = 70 \text{ mA}$  (per chip) until the brightness becomes  $\leq 50\%$  of its original value.



### 4.3.3 BACKLIGHT PIN ASSIGNMENT

Pin	Symbol	Description	Remark
1	$V_i$	Converter input voltage	12V
2	$V_{GND}$	Converter ground	Ground
3	EN	Enable pin	3.3 V
4	ADJ	Backlight Adjust	PWM Dimming (Hi: 3.3 $V_{DC}$ , Lo: 0 $V_{DC}$ )
5	NC	Not Connect	

Note (1) Connector Part No.:

### 4.4 LVDS INPUT SIGNAL SPECIFICATIONS

#### 4.4.1 COLOR DATA INPUT ASSIGNMENT

The brightness of each primary color (red, green and blue) is based on the 8-bit gray scale data input for the color. The higher the binary input, the brighter the color. The table below provides the assignment of color versus data input.

Color		Data Signal																							
		Red								Green								Blue							
		R7	R6	R5	R4	R3	R2	R1	R0	G7	G6	G5	G4	G3	G2	G1	G0	B7	B6	B5	B4	B3	B2	B1	B0
Basic Colors	Black	0	0	0	0	0	0	0	0	0	0	0	0	0	0	0	0	0	0	0	0	0	0	0	0
	Red	1	1	1	1	1	1	1	1	0	0	0	0	0	0	0	0	0	0	0	0	0	0	0	0
	Green	0	0	0	0	0	0	0	0	1	1	1	1	1	1	1	1	0	0	0	0	0	0	0	0
	Blue	0	0	0	0	0	0	0	0	0	0	0	0	0	0	0	0	1	1	1	1	1	1	1	1
	Cyan	0	0	0	0	0	0	0	0	1	1	1	1	1	1	1	1	1	1	1	1	1	1	1	1
	Magenta	1	1	1	1	1	1	1	1	0	0	0	0	0	0	0	0	1	1	1	1	1	1	1	1
	Yellow	1	1	1	1	1	1	1	1	1	1	1	1	1	1	1	1	0	0	0	0	0	0	0	0
	White	1	1	1	1	1	1	1	1	1	1	1	1	1	1	1	1	1	1	1	1	1	1	1	1
Gray Scale Of Red	Red(0) / Dark	0	0	0	0	0	0	0	0	0	0	0	0	0	0	0	0	0	0	0	0	0	0	0	0
	Red(1)	0	0	0	0	0	0	0	1	0	0	0	0	0	0	0	0	0	0	0	0	0	0	0	0
	Red(2)	0	0	0	0	0	0	1	0	0	0	0	0	0	0	0	0	0	0	0	0	0	0	0	0
	⋮	⋮	⋮	⋮	⋮	⋮	⋮	⋮	⋮	⋮	⋮	⋮	⋮	⋮	⋮	⋮	⋮	⋮	⋮	⋮	⋮	⋮	⋮	⋮	⋮
	⋮	⋮	⋮	⋮	⋮	⋮	⋮	⋮	⋮	⋮	⋮	⋮	⋮	⋮	⋮	⋮	⋮	⋮	⋮	⋮	⋮	⋮	⋮	⋮	⋮
	Red(253)	1	1	1	1	1	1	0	1	0	0	0	0	0	0	0	0	0	0	0	0	0	0	0	0
	Red(254)	1	1	1	1	1	1	1	0	0	0	0	0	0	0	0	0	0	0	0	0	0	0	0	0
	Red(255)	1	1	1	1	1	1	1	1	0	0	0	0	0	0	0	0	0	0	0	0	0	0	0	0
Gray Scale Of Green	Green(0) / Dark	0	0	0	0	0	0	0	0	0	0	0	0	0	0	0	0	0	0	0	0	0	0	0	0
	Green(1)	0	0	0	0	0	0	0	0	0	0	0	0	0	0	1	0	0	0	0	0	0	0	0	0
	Green(2)	0	0	0	0	0	0	0	0	0	0	0	0	0	0	1	0	0	0	0	0	0	0	0	0
	⋮	⋮	⋮	⋮	⋮	⋮	⋮	⋮	⋮	⋮	⋮	⋮	⋮	⋮	⋮	⋮	⋮	⋮	⋮	⋮	⋮	⋮	⋮	⋮	⋮
	⋮	⋮	⋮	⋮	⋮	⋮	⋮	⋮	⋮	⋮	⋮	⋮	⋮	⋮	⋮	⋮	⋮	⋮	⋮	⋮	⋮	⋮	⋮	⋮	⋮
	Green(253)	0	0	0	0	0	0	0	0	1	1	1	1	1	1	0	1	0	0	0	0	0	0	0	0
	Green(254)	0	0	0	0	0	0	0	0	1	1	1	1	1	1	1	0	0	0	0	0	0	0	0	0
	Green(255)	0	0	0	0	0	0	0	0	1	1	1	1	1	1	1	1	0	0	0	0	0	0	0	0
Gray Scale Of Blue	Blue(0) / Dark	0	0	0	0	0	0	0	0	0	0	0	0	0	0	0	0	0	0	0	0	0	0	0	0
	Blue(1)	0	0	0	0	0	0	0	0	0	0	0	0	0	0	0	0	0	0	0	0	0	0	0	1
	Blue(2)	0	0	0	0	0	0	0	0	0	0	0	0	0	0	0	0	0	0	0	0	0	0	1	0
	⋮	⋮	⋮	⋮	⋮	⋮	⋮	⋮	⋮	⋮	⋮	⋮	⋮	⋮	⋮	⋮	⋮	⋮	⋮	⋮	⋮	⋮	⋮	⋮	⋮
	⋮	⋮	⋮	⋮	⋮	⋮	⋮	⋮	⋮	⋮	⋮	⋮	⋮	⋮	⋮	⋮	⋮	⋮	⋮	⋮	⋮	⋮	⋮	⋮	⋮
	Blue(253)	0	0	0	0	0	0	0	0	0	0	0	0	0	0	0	0	1	1	1	1	1	1	0	1
	Blue(254)	0	0	0	0	0	0	0	0	0	0	0	0	0	0	0	0	1	1	1	1	1	1	1	0
	Blue(255)	0	0	0	0	0	0	0	0	0	0	0	0	0	0	0	0	1	1	1	1	1	1	1	1

Note (1) 0: Low Level Voltage, 1: High Level Voltage

## 4.5 DISPLAY TIMING SPECIFICATIONS

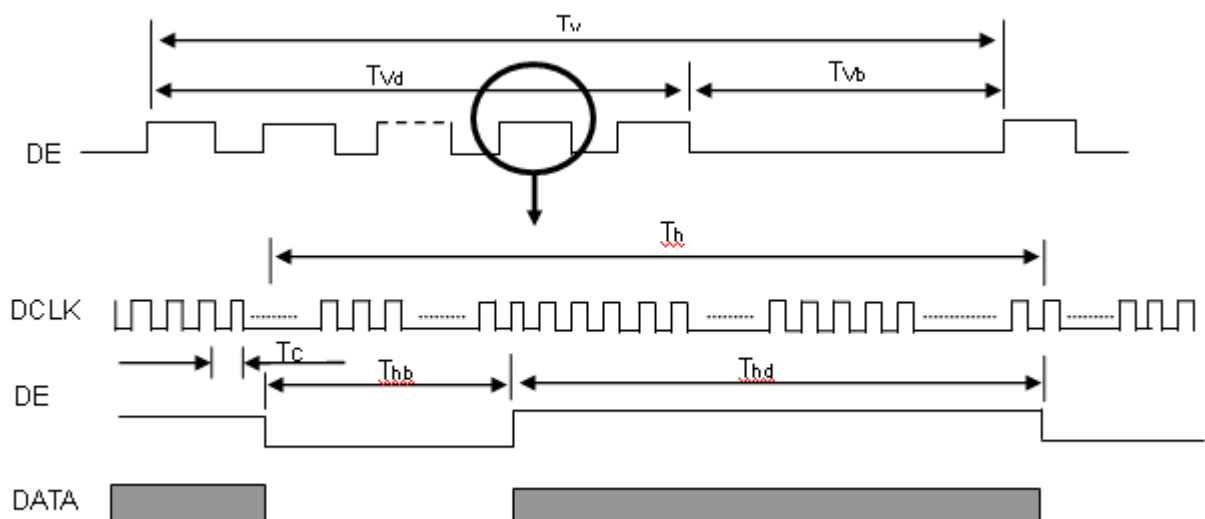
The input signal timing specifications are shown as the following table and timing diagram.

Signal	Item	Symbol	Min.	Typ.	Max.	Unit	Note
LVDS Clock	Frequency	F <sub>c</sub>	63	76	96	MHz	-
	Period	T <sub>c</sub>		13.15		ns	
	Input cycle to cycle jitter	T <sub>rcj</sub>	-0.02*T <sub>c</sub>		0.02*T <sub>c</sub>	ns	(3)
	Input Clock to data skew	TLVCCS	-0.02*T <sub>c</sub>		0.02*T <sub>c</sub>	ns	(4)
	Spread spectrum modulation range	F <sub>clkin_mod</sub>	FC*98%		FC*102%	MHz	(5)
	Spread spectrum modulation frequency	F <sub>SSM</sub>			200	KHz	
Vertical Display Term	Frame Rate	Fr	50	60	76	Hz	T <sub>v</sub> =T <sub>v</sub> d+T <sub>v</sub> b
	Total	T <sub>v</sub>	800	806	815	Th	-
	Active Display	T <sub>v</sub> d	768	768	768	Th	-
	Blank	T <sub>v</sub> b	32	38	47	Th	-
Horizontal Display Term	Total	T <sub>h</sub>	1500	1560	1570	T <sub>c</sub>	T <sub>h</sub> =T <sub>h</sub> d+T <sub>h</sub> b
	Active Display	T <sub>h</sub> d	1366	1366	1366	T <sub>c</sub>	-
	Blank	T <sub>h</sub> b	134	194	204	T <sub>c</sub>	-

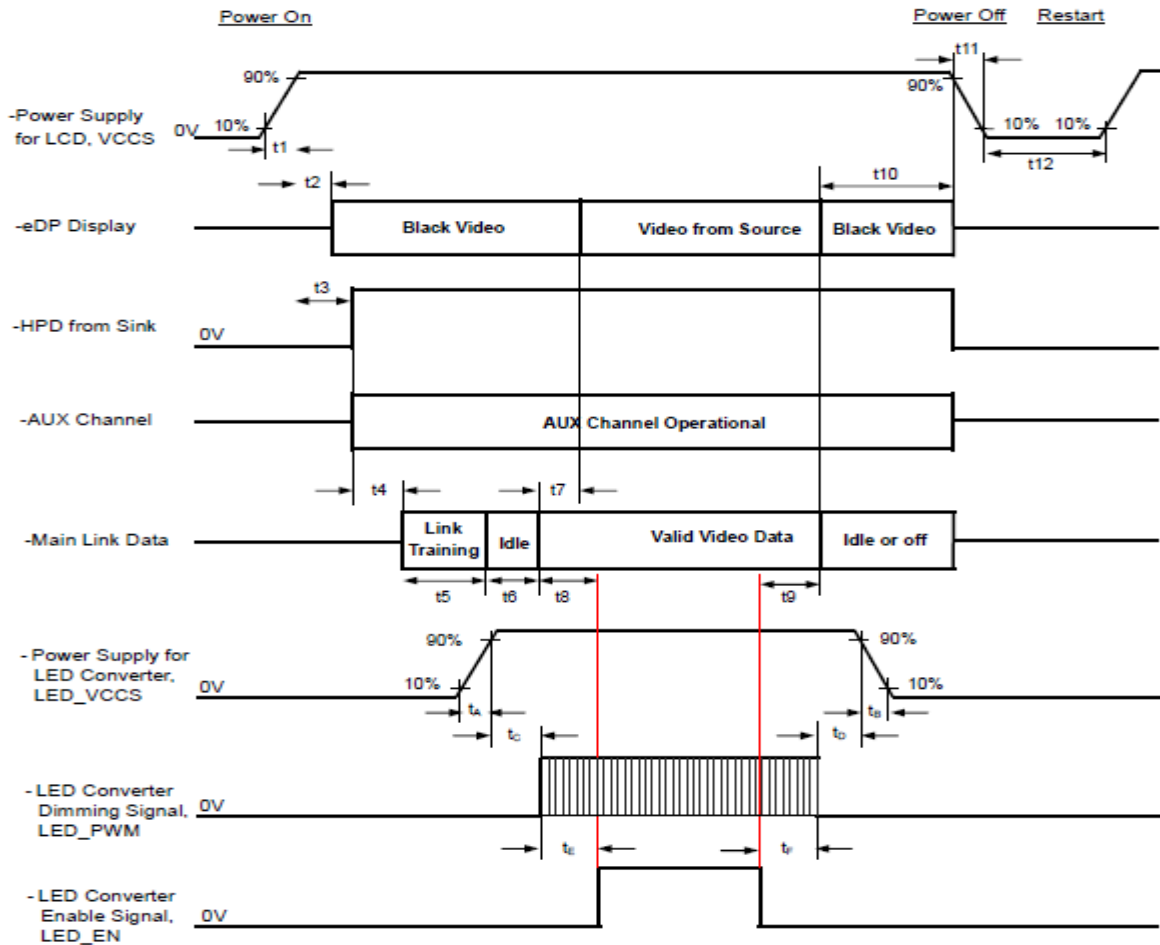
Note (1) Because this module is operated by DE only mode, Hsync and Vsync input signals are ignored.

Note (2) The T<sub>v</sub>(T<sub>v</sub>d+T<sub>v</sub>b) must be integer, otherwise, this module would operate abnormally.

### INPUT SIGNAL TIMING DIAGRAM



## 4.6 POWER ON/OFF SEQUENCE



Timing Specifications:

Parameter	Value			Units
	Min	Typ	Max	
T1	0.5	-	10	ms
T2	0	-	50	ms
T3	0	-	50	ms
T4	500	-	-	ms
T5	200	-	-	ms
T6	20	-	-	ms
T7	5	-	300	ms
T8	10	-	-	ms
T9	10	-	-	ms
T10	20	-	-	ms

Note (1) Please avoid floating state of interface signal at invalid period.

Note (2) When the interface signal is invalid, be sure to pull down the power supply of LCD VCC to 0 V.

Note (3) The Backlight converter power must be turned on after the power supply for the logic and the interface signal is valid. The Backlight converter power must be turned off before the power supply for the logic and the interface signal is invalid.



## 5. OPTICAL CHARACTERISTICS

### 5.1 TEST CONDITIONS

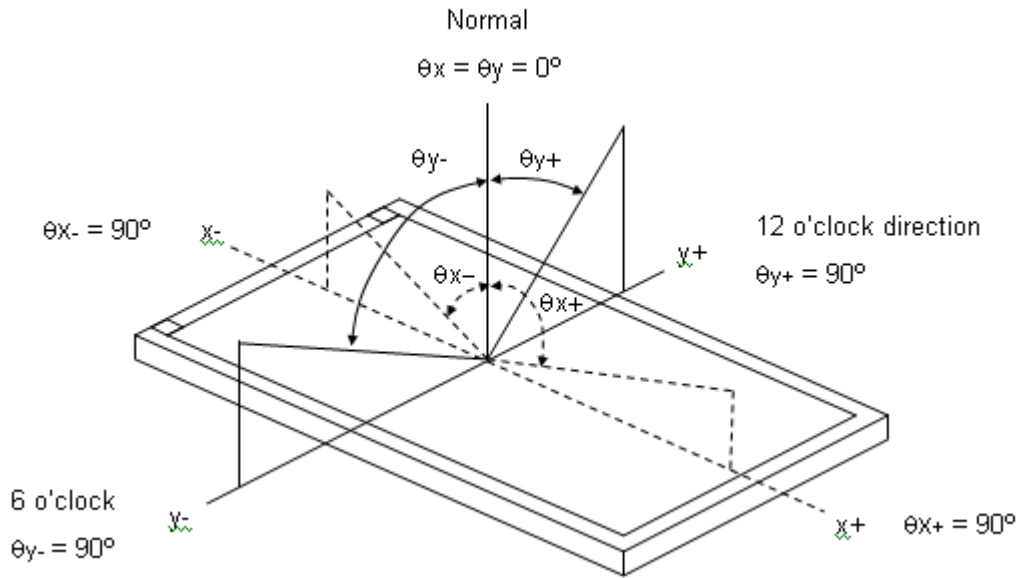
Item	Value	Unit
Ambient Temperature (Ta)	25±2	°C
Ambient Humidity (Ha)	50±10	%RH
Supply Voltage	According to typical value in "ELECTRICAL CHARACTERISTICS"	
Input Signal		
LED Light Bar Input Current Per Input Pin		

### 5.2 OPTICAL SPECIFICATIONS

The relative measurement methods of optical characteristics are shown in 5.2 and all items are measured at the center point of screen except white variation. The following items should be measured under the test conditions described in 5.1 and stable environment shown in Note (5).

Item	Symbol	Condition	Min.	Typ.	Max.	Unit	Note	
Color Chromaticity (CIE 1931)	Red	Rx	$\theta_x=0^\circ, \theta_y=0^\circ$ CS-2000 R=G=B=255 Gray scale	Typ – 0.045	0.627	Typ + 0.045	-	(1), (5)
		Ry			0.339			
	Green	Gx			0.328			
		Gy			0.590			
	Blue	Bx			0.160			
		By			0.063			
	White	Wx			0.313			
		Wy			0.329			
Center Luminance of White (Center of Screen)	L <sub>c</sub>		400	500	-	cd/m <sup>2</sup>	(4), (5)	
Contrast Ratio	CR		400	600	-	-	(2), (5)	
Response Time	T <sub>R</sub>	$\theta_x=0^\circ, \theta_y=0^\circ$	-	3	8	ms	(3)	
	T <sub>F</sub>		-	8	13			
White Variation	W	$\theta_x=0^\circ, \theta_y=0^\circ$	70	-	-	%	(5), (6)	
Viewing Angle	Horizontal	$\theta_{x-} + \theta_{x+}$	CR ≥ 10	140	160	---	Deg.	(1), (5)
	Vertical	$\theta_{y-} + \theta_{y+}$		130	150	---		

Note (1) Definition of Viewing Angle ( $\theta_x, \theta_y$ ):



Note (2) Definition of Contrast Ratio (CR):

The contrast ratio can be calculated by the following expression.

$$\text{Contrast Ratio (CR)} = L_{255} / L_0$$

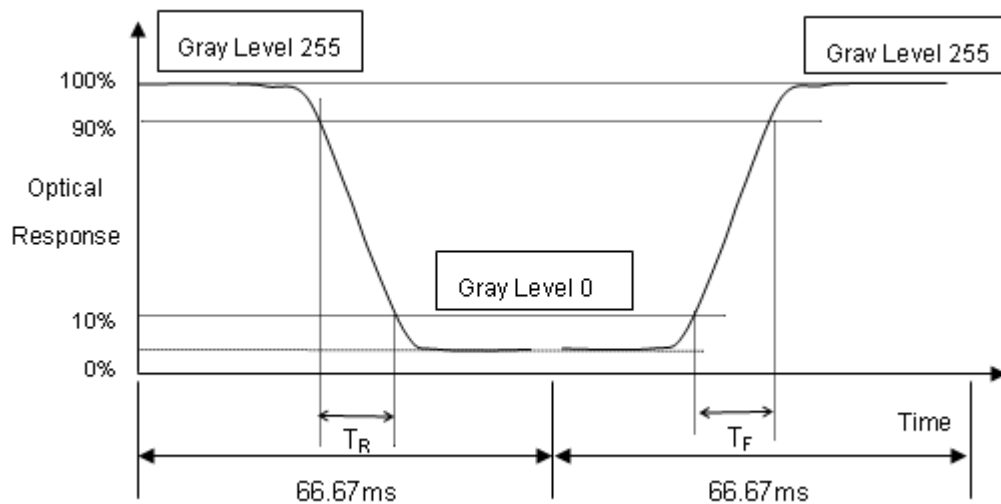
L255: Luminance of gray level 255

L 0: Luminance of gray level 0

$$\text{CR} = \text{CR} (5)$$

CR (X) is corresponding to the Contrast Ratio of the point X at Figure in Note (6).

Note (3) Definition of Response Time ( $T_R, T_F$ ):



Note (4) Definition of Luminance of White ( $L_c$ ):

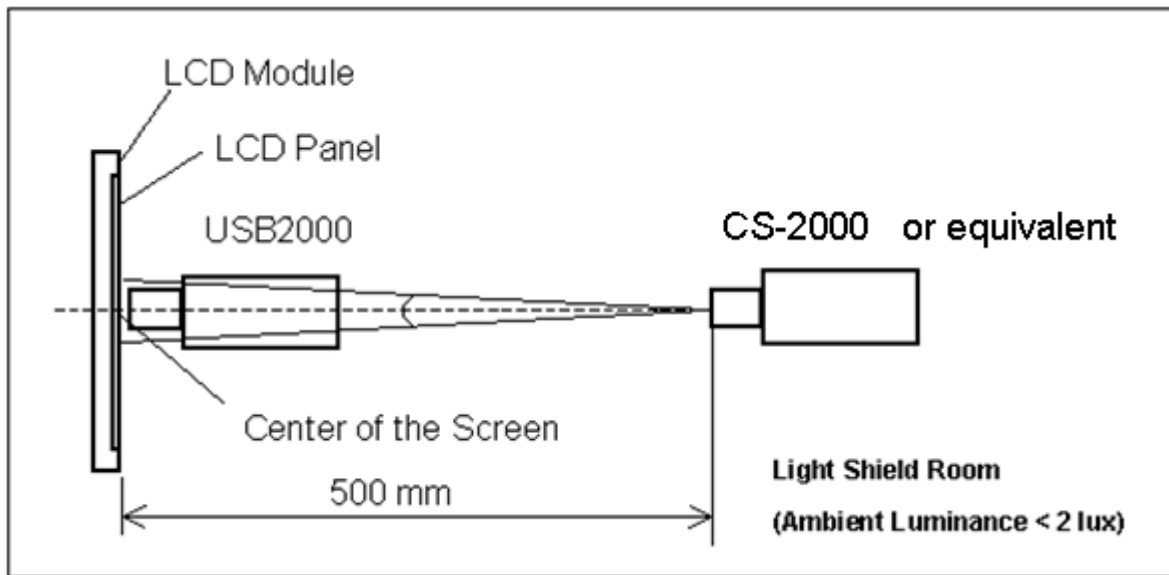
Measure the luminance of gray level 255 at center point

$$L_c = L(5)$$

$L(x)$  is corresponding to the luminance of the point X at Figure in Note (6).

Note (5) Measurement Setup:

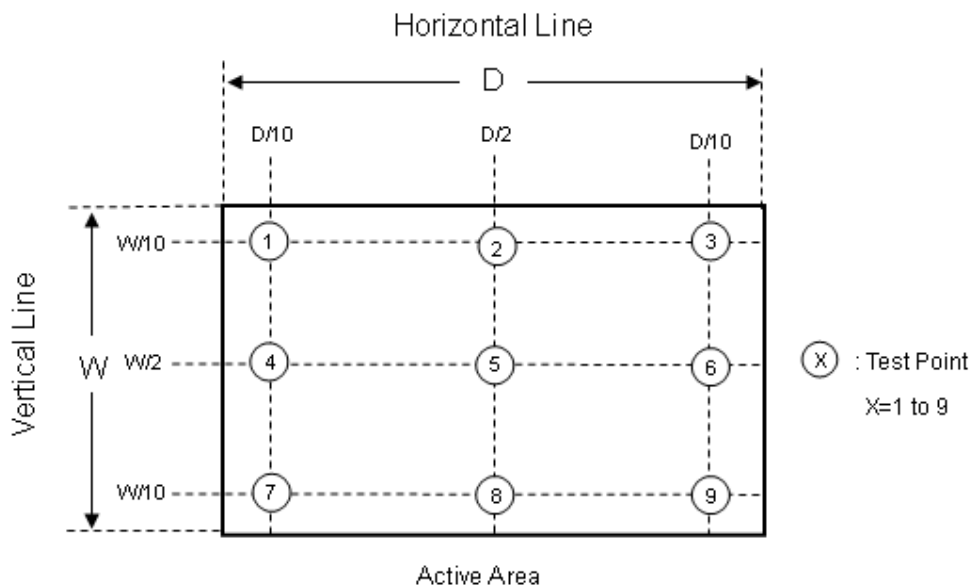
The LCD module should be stabilized at given temperature for 40 minutes to avoid abrupt temperature change during measuring. In order to stabilize the luminance, the measurement should be executed after lighting Backlight for 40 minutes in a windless room.



Note (6) Definition of White Variation ( $\delta W$ ):

Measure the luminance of gray level 255 at 9 points

$$\delta W = ( \text{Minimum } [L(1) \sim L(9)] / \text{Maximum } [L(1) \sim L(9)] ) * 100\%$$



## 6. RELIABILITY TEST ITEM

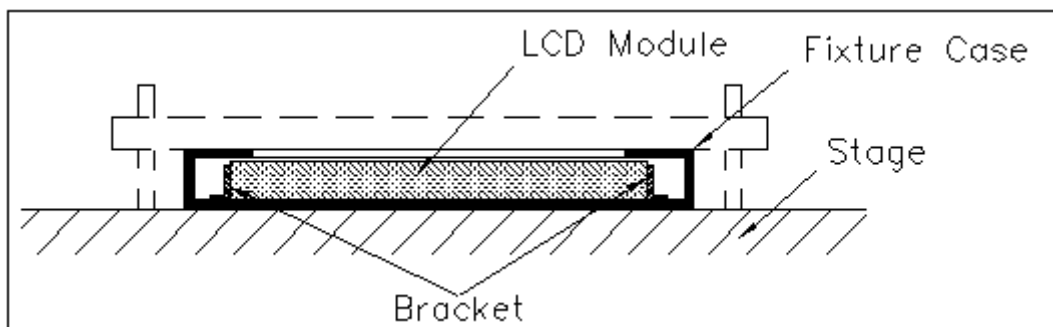
Items	Required Condition	Note
High Temperature Storage	50°C , 240hours	(1)(2)
Low Temperature Storage	-20°C , 240hours	(1)(2)
Thermal Shock Test	-20°C/30min , 50°C / 30min , 100 cycles	(1)(2)
High Temperature Operation	50°C , 240hours	(1)(2)
Low Temperature Operation	0°C , 240hours	(1)(2)
High Temperature & High Humidity Operation Test	50°C , RH 90%, 240 hours	(1)(2)
Vibration Test (Non-operation)	Acceleration: 1.5 Grms Wave: Half-sine Frequency: 10 - 300 Hz Sweep: 30 Minutes each Axis (X, Y, Z)	(3)
Shock Test (Non-operation)	Acceleration: 50 G Wave: Half-sine Active Time: 11 ms Direction : ± X, ± Y, ± Z.(one time for each Axis)	(3)
ESD (Electro Static Discharge)	Contact Discharge: ± 8KV, 150pF(330Ω)	(1)
	Air Discharge: ± 15KV, 150pF(330Ω)	(1)

Note (1) criteria : Normal display image with no obvious non-uniformity and no line defect.

Note (2) Evaluation should be tested after storage at room temperature for more than two hour

Note (3) At testing Vibration and Shock, the fixture in holding the module has to be hard and rigid enough so that the module would not be twisted or bent by the fixture.

The fixing condition is shown as below:

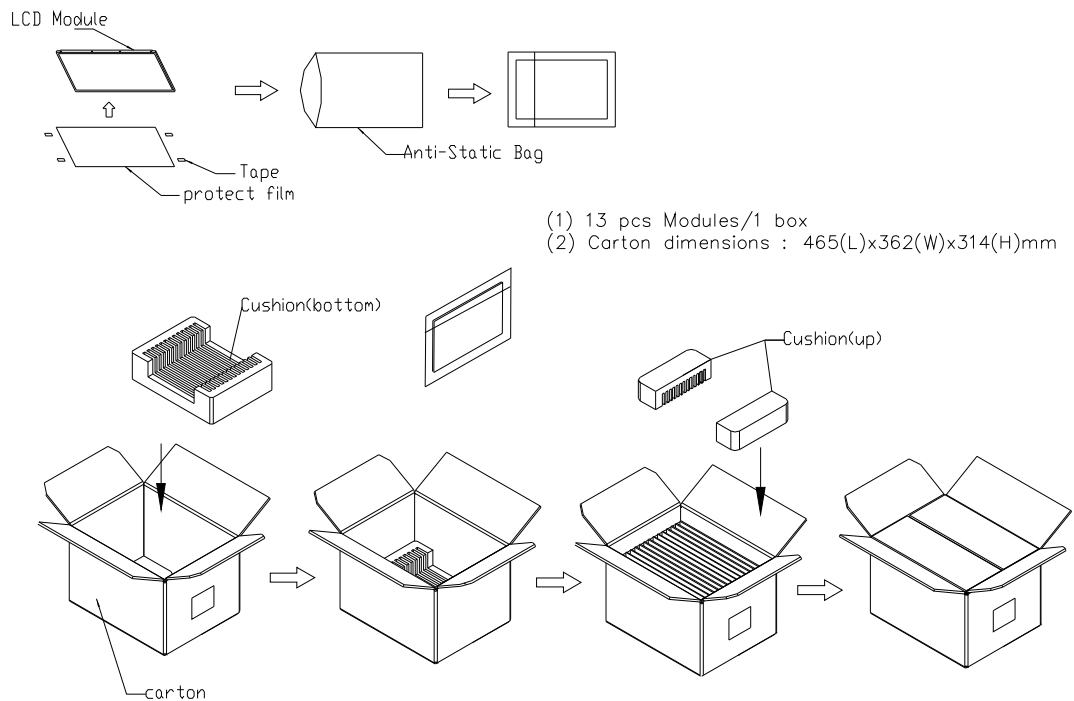


## 7. PACKING

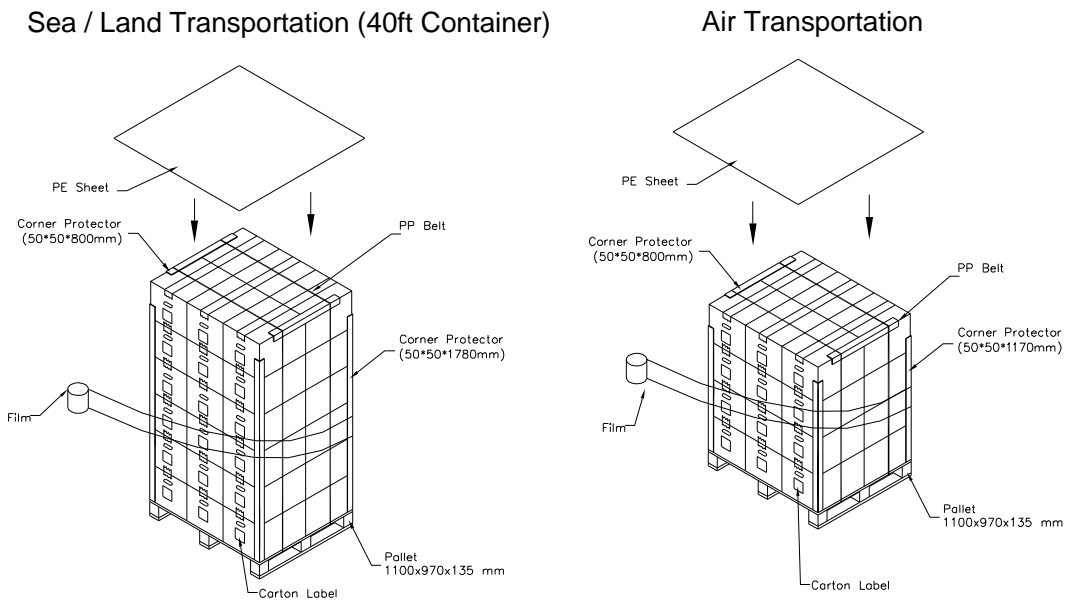
### 7.1 PACKING SPECIFICATIONS

- (1) 13 pcs LCD modules / 1 Box
- (2) Box dimensions: 465 (L) X 362 (W) X 314 (H) mm
- (3) Weight: approximately 12Kg (13 modules per box)

### 7.2 PACKING METHOD

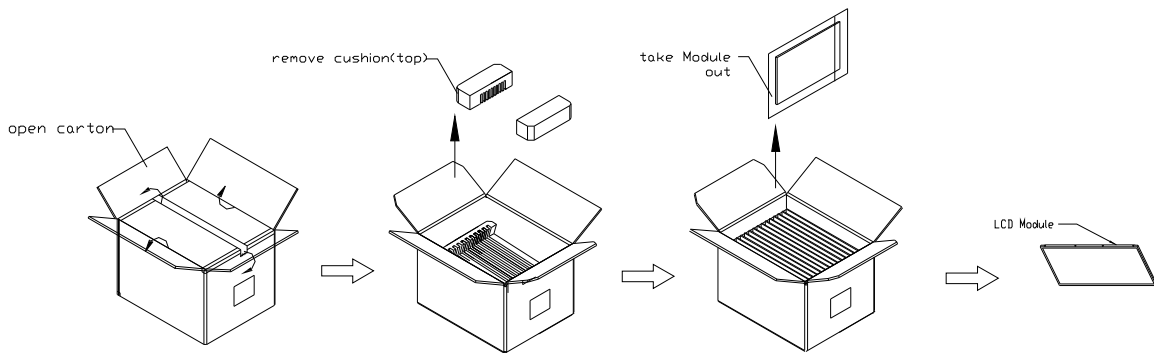


**Figure. 7-1 Packing**



**Figure. 7-2 Packing**

### 7.3 UN-PACKING METHOD

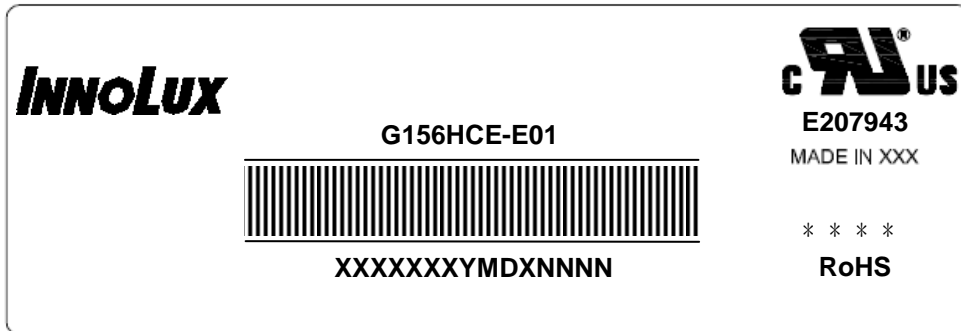


**Figure. 7-3 UN-Packing**

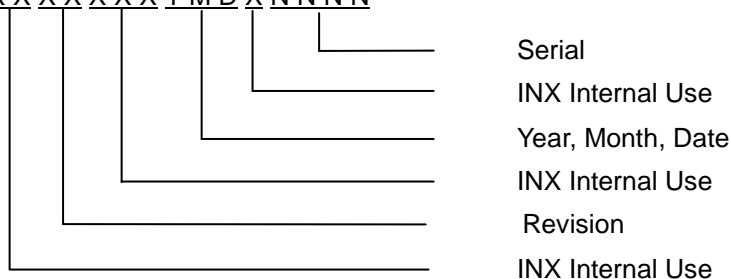
## 8. MODULE LABEL

### 10.1 INX MODULE LABEL

The barcode nameplate is pasted on each module as illustration, and its definitions are as following explanation.



- (a) Model Name: G156HCE-E01
- (b) Revision: Rev. XX, for example: A1, B1, C1, C2 ...etc.
- (c) \* \* \* \* : Factory ID
- (d) Serial ID: X X X X X X Y M D X N N N N



Serial ID includes the information as below:

- (a) Manufactured Date: Year: 1~9, for 2011~2019  
 Month: 1~9, A~C, for Jan. ~ Dec.  
 Day: 1~9, A~Y, for 1<sup>st</sup> to 31<sup>st</sup>, exclude I , O and U
- (b) Revision Code: cover all the change
- (c) Serial No.: Manufacturing sequence of product

## 9. PRECAUTIONS

### 9.1 ASSEMBLY AND HANDLING PRECAUTIONS

- (1) Do not apply rough force such as bending or twisting to the module during assembly.
- (2) To assemble or install module into user's system can be only in clean working areas. The dust and oil may cause electrical short or worsen the polarizer.
- (3) It's not permitted to have pressure or impulse on the module because the LCD panel and Backlight will be damaged.
- (4) Always follow the correct power sequence when LCD module is connecting and operating. This can prevent damage to the CMOS LSI chips during latch-up.
- (5) Do not pull the I/F connector in or out while the module is operating.
- (6) Do not disassemble the module.
- (7) Use a soft dry cloth without chemicals for cleaning, because the surface of polarizer is very soft and easily scratched.
- (8) It is dangerous that moisture come into or contacted the LCD module, because moisture may damage LCD module when it is operating.
- (9) High temperature or humidity may reduce the performance of module. Please store LCD module within the specified storage conditions.
- (10) When ambient temperature is lower than 10°C may reduce the display quality. For example, the response time will become slowly.

### 9.2 STORAGE PRECAUTIONS

- (1) Do not leave the module in high temperature, and high humidity for a long time. It is highly recommended to store the module with temperature from 0°C to 35°C and relative humidity of less than 70%
- (2) Do not store the TFT – LCD module in direct sunlight
- (3) The module should be stored in dark place. It is prohibited to apply sunlight or fluorescent light in storing

### 9.3 OPERATION PRECAUTIONS

- (1) The LCD product should be operated under normal condition.  
 Normal condition is defined as below :  
 Temperature : 20±15°C  
 Humidity: 65±20%  
 Display pattern : continually changing pattern(Not stationary)
- (2) If the product will be used in extreme conditions such as high temperature, high humidity, high altitude, display pattern or operation time etc... It is strongly recommended to contact INNOLUX for application engineering advice. Otherwise, its reliability and function may not be guaranteed.

### 9.4 SAFETY PRECAUTIONS

- (1) If the liquid crystal material leaks from the panel, it should be kept away from the eyes or mouth. In case of contact with hands, skin or clothes, it has to be washed away thoroughly with soap.
- (2) After the module's end of life, it is not harmful in case of normal operation and storage.



## 9.5 SAFETY STANDARDS

The LCD module should be certified with safety regulations as follows:

- (1) UL60950-1 or updated standard.
- (2) IEC60950-1 or updated standard.

## 9.6 OTHER

When fixed patterns are displayed for a long time, remnant image is likely to occur.

## 10. Outline Drawing

