



Rail-to-Rail Operational Amplifiers

Features

- Wide Supply Operation Range +4.5V to +20V
- Input Common Voltage Range Beyond the Rails
- Rail-to-Rail Output Voltage Swing
- High Peak Source Capability 1300mA
- High Peak Sink Capability 850mA
- Low Input Offset Voltage 3mV (Typical)
- Wide -3dB Bandwidth 35MHz
- Quiescent Current: 2.2mA
- Large DC Voltage Gain 80dB (Typical)
- Slew-Rate 50V/ μ s
- Unit-Gain Stable

Applications

- Portable Equipment
- LCD-TV Equipment
- Battery-Powered Equipment
- ASIC Input or Output Amplifier
- Low Power/Low Voltage Applications

General Description

The G1582 consists of one independent, high gain, internally frequency compensated operational amplifiers which was designed to operate from a single power supply over a wide range of voltages. Operation from split power supplies is also possible. The input common mode range of the G1582 can be beyond the rails, and the G1582 is with rail-to-rails output voltage swing. The quiescent current is 2.2mA, typically.

The G1582 also feature fast slewing and settle-times, as well as high output drive capability of source 1300mA /sink 850mA. These features make this amplifier ideal for use as reference buffers for TFT-LCD. Other applications include battery power, portable devices, and anywhere low power consumption is important.

The G1582 is housed in a TDFN3X3-8 & MSOP-8 (FD) package.

Ordering Information

ORDER NUMBER	MARKING	TEMP. RANGE	PACKAGE (Green)
G1582RD1U	1582	-40°C to 85°C	TDFN3X3-8
G1582F51U	G1582	-40°C~ +85°C	MSOP-8 (FD)

Note: RD: TDFN3X3-8 F5: MSOP-8 (FD)

1: Bonding Code

U: Tape & Reel

Pin Configuration

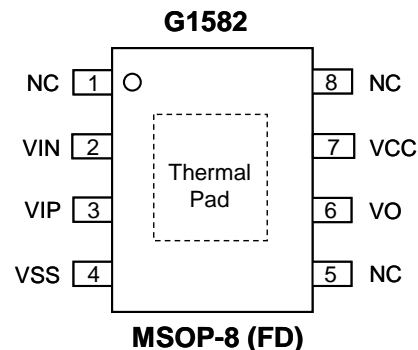
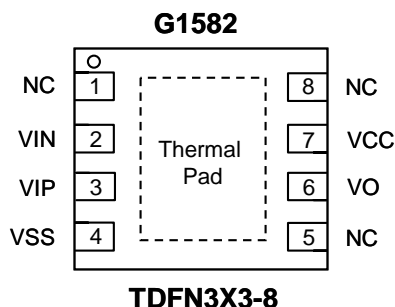

Note: Recommend connecting the Thermal Pad to the Pin#4 VSS for excellent power dissipation.