



# Product Specification

G286HAN01.0

AU OPTRONICS CORPORATION

Preliminary Specification

Final Specification

<b>Module</b>	28.6" Color TFT-LCD
<b>Model Name</b>	G286HAN01.0

<b>Customer</b>	<b>Date</b>
_____	_____
<b>Checked &amp; Approved by</b>	
_____	_____
Note: This Specification is subject to change without notice.	

<b>Approved by</b>	<b>Date</b>
Crystal Hsieh	2016/03/14
<b>Prepared by</b>	
Jimmy Tsai	2016/03/14
General Display Business Division / AU Optonics corporation	



**Contents**

- 1. Operating Precautions .....4
- 2. General Description .....5
  - 2.1 Display Characteristics ..... 5
  - 2.2 Optical Characteristics..... 6
- 3. Functional Block Diagram .....9
- 4. Absolute Maximum Ratings.....10
  - 4.1 TFT LCD Module ..... 10
  - 4.2 Backlight Unit..... 10
  - 4.3 Absolute Ratings of Environment ..... 10
- 5. Electrical Characteristics..... 11
  - 5.1 TFT LCD Module ..... 11
  - 5.2 Backlight Unit..... 13
- 6. Signal Characteristic..... 14
  - 6.1 Pixel Format Image ..... 14
  - 6.2 Signal Description..... 15
  - 6.3 The Input Data Format ..... 17
  - 6.4 Interface Timing ..... 18
  - 6.5 Power ON/OFF Sequence..... 19
- 7. Connector & Pin Assignment .....20
  - 7.1 TFT LCD Module: LVDS Connector ..... 20
  - 7.2 Backlight Unit: LED Light Bar Connector..... 21
- 8. Reliability Test .....22
- 9. Mechanical Characteristics .....23
- 10. Label and Packaging.....24
  - 10.1 Shipping Label (on the rear side of TFT-LCD display)..... 24
  - 10.2 Carton Package..... 24
- 11. Safety .....25
  - 11.1 Sharp Edge Requirements..... 25
  - 11.2 Materials ..... 25
  - 11.3 Capacitors..... 25
  - 11.4 National Test Lab Requirement..... 25



**Record of Revision**

Version and Date	Page	Old description	New Description	Remark																																																																		
0.1 2016/03/01	All	First Edition for Customer	All																																																																			
0.2 2016/03/14	6	<table border="1"> <thead> <tr> <th>Item</th> <th>Unit</th> <th>Conditions</th> <th>Min.</th> <th>Typ.</th> <th>Max.</th> <th>Note</th> </tr> </thead> <tbody> <tr> <td>White Luminance</td> <td>[cd/m<sup>2</sup>]</td> <td>I<sub>b</sub>= 100 mA, R13</td> <td>800</td> <td>1000</td> <td>∞</td> <td>1-</td> </tr> </tbody> </table>	Item	Unit	Conditions	Min.	Typ.	Max.	Note	White Luminance	[cd/m <sup>2</sup> ]	I <sub>b</sub> = 100 mA, R13	800	1000	∞	1-	<table border="1"> <thead> <tr> <th>Item</th> <th>Unit</th> <th>Conditions</th> <th>Min.</th> <th>Typ.</th> <th>Max.</th> <th>Note</th> </tr> </thead> <tbody> <tr> <td>White Luminance</td> <td>[cd/m<sup>2</sup>]</td> <td>I<sub>b</sub>= 120 mA</td> <td>800</td> <td>1000</td> <td>∞</td> <td>1-</td> </tr> </tbody> </table>	Item	Unit	Conditions	Min.	Typ.	Max.	Note	White Luminance	[cd/m <sup>2</sup> ]	I <sub>b</sub> = 120 mA	800	1000	∞	1-																																							
Item	Unit	Conditions	Min.	Typ.	Max.	Note																																																																
White Luminance	[cd/m <sup>2</sup> ]	I <sub>b</sub> = 100 mA, R13	800	1000	∞	1-																																																																
Item	Unit	Conditions	Min.	Typ.	Max.	Note																																																																
White Luminance	[cd/m <sup>2</sup> ]	I <sub>b</sub> = 120 mA	800	1000	∞	1-																																																																
	18	<table border="1"> <thead> <tr> <th rowspan="3">Horizontal Section</th> <th>Period</th> <th>I<sub>on</sub></th> <th>TDD</th> <th>258</th> <th>TBD</th> <th rowspan="3">Clock</th> </tr> </thead> <tbody> <tr> <th>Active</th> <th>I<sub>op</sub></th> <th>TDD</th> <th>132</th> <th>TBD</th> </tr> <tr> <th>Blanking</th> <th>I<sub>bp</sub></th> <th>TDD</th> <th>64</th> <th>TBD</th> </tr> </tbody> </table>	Horizontal Section	Period	I <sub>on</sub>	TDD	258	TBD	Clock	Active	I <sub>op</sub>	TDD	132	TBD	Blanking	I <sub>bp</sub>	TDD	64	TBD	<table border="1"> <thead> <tr> <th rowspan="3">Horizontal Section</th> <th>Period</th> <th>T<sub>on</sub></th> <th>TRF</th> <th>128</th> <th>TAD</th> </tr> </thead> <tbody> <tr> <th>Active</th> <th>I<sub>op</sub></th> <th>TDD</th> <th>98</th> <th>TAD</th> </tr> <tr> <th>Blanking</th> <th>T<sub>bp</sub></th> <th>TRF</th> <th>32</th> <th>TAD</th> </tr> </tbody> </table>	Horizontal Section	Period	T <sub>on</sub>	TRF	128	TAD	Active	I <sub>op</sub>	TDD	98	TAD	Blanking	T <sub>bp</sub>	TRF	32	TAD																																		
Horizontal Section	Period	I <sub>on</sub>		TDD	258	TBD	Clock																																																															
	Active	I <sub>op</sub>		TDD	132	TBD																																																																
	Blanking	I <sub>bp</sub>	TDD	64	TBD																																																																	
Horizontal Section	Period	T <sub>on</sub>	TRF	128	TAD																																																																	
	Active	I <sub>op</sub>	TDD	98	TAD																																																																	
	Blanking	T <sub>bp</sub>	TRF	32	TAD																																																																	
	19	<table border="1"> <thead> <tr> <th colspan="5">Power Sequence Timing</th> </tr> <tr> <th rowspan="2">Parameter</th> <th colspan="3">Value</th> <th rowspan="2">Units</th> </tr> <tr> <th>Min.</th> <th>Typ.</th> <th>Max.</th> </tr> </thead> <tbody> <tr> <td>T1</td> <td>0.5</td> <td>∞</td> <td>10</td> <td rowspan="7">ms</td> </tr> <tr> <td>T2</td> <td>30</td> <td>40</td> <td>50</td> </tr> <tr> <td>T11</td> <td>0</td> <td>16</td> <td>50</td> </tr> <tr> <td>T12</td> <td>∞</td> <td>∞</td> <td>10</td> </tr> <tr> <td>T13</td> <td>1000</td> <td>∞</td> <td>∞</td> </tr> </tbody> </table>	Power Sequence Timing					Parameter	Value			Units	Min.	Typ.	Max.	T1	0.5	∞	10	ms	T2	30	40	50	T11	0	16	50	T12	∞	∞	10	T13	1000	∞	∞	<table border="1"> <thead> <tr> <th colspan="4">Power Sequence Timing</th> </tr> <tr> <th rowspan="2">Parameter</th> <th colspan="2">Value</th> <th rowspan="2">Units</th> </tr> <tr> <th>Min.</th> <th>Max.</th> </tr> </thead> <tbody> <tr> <td>T1</td> <td>0.5</td> <td>10</td> <td rowspan="7">ms</td> </tr> <tr> <td>T2</td> <td>30</td> <td>50</td> </tr> <tr> <td>T3</td> <td>200</td> <td>∞</td> </tr> <tr> <td>T4</td> <td>200</td> <td>∞</td> </tr> <tr> <td>T5</td> <td>0</td> <td>50</td> </tr> <tr> <td>T6</td> <td>0</td> <td>10</td> </tr> <tr> <td>T7</td> <td>1000</td> <td>∞</td> </tr> </tbody> </table>	Power Sequence Timing				Parameter	Value		Units	Min.	Max.	T1	0.5	10	ms	T2	30	50	T3	200	∞	T4	200	∞	T5	0	50	T6	0	10	T7	1000	∞	
Power Sequence Timing																																																																						
Parameter	Value			Units																																																																		
	Min.	Typ.	Max.																																																																			
T1	0.5	∞	10	ms																																																																		
T2	30	40	50																																																																			
T11	0	16	50																																																																			
T12	∞	∞	10																																																																			
T13	1000	∞	∞																																																																			
Power Sequence Timing																																																																						
Parameter	Value		Units																																																																			
	Min.	Max.																																																																				
T1	0.5	10	ms																																																																			
T2	30	50																																																																				
T3	200	∞																																																																				
T4	200	∞																																																																				
T5	0	50																																																																				
T6	0	10																																																																				
T7	1000	∞																																																																				



## 1. Operating Precautions

- 1) Since front polarizer is easily damaged, pay attention not to scratch it.
- 2) Be sure to turn off power supply when inserting or disconnecting from input connector.
- 3) Wipe off water drop immediately. Long contact with water may cause discoloration or spots.
- 4) When the panel surface is soiled, wipe it with absorbent cotton or other soft cloth.
- 5) Since the panel is made of glass, it may break or crack if dropped or bumped on hard surface.
- 6) Since CMOS LSI is used in this module, take care of static electricity and insure human earth when handling.
- 7) Do not open or modify the Module Assembly.
- 8) In case if a Module has to be put back into the packing container slot after once it was taken out from the container, take it easily, or the TFT Module may be damaged.
- 9) At the insertion or removal of the Signal Interface Connector, be sure not to rotate nor tilt the Interface Connector of the TFT Module.
- 10) After installation of the TFT Module into an enclosure, do not twist nor bend the TFT Module even momentary. At designing the enclosure, it should be taken into consideration that no bending/twisting forces are applied to the TFT Module from outside. Otherwise the TFT Module may be damaged.
- 11) Small amount of materials having no flammability grade is used in the LCD module. The LCD module should be supplied by power complied with requirements of Limited Power Source (IEC60950 or UL1950), or be applied exemption.
- 12) Severe temperature condition may result in different luminance, response time and LED life time.
- 13) The data on this specification sheet is applicable when LCD module is placed in landscape position.
- 14) Continuous displaying fixed pattern may induce image sticking. It is recommended to use screen saver or shuffle content periodically if fixed pattern is displayed on the screen.



## 2. General Description

This specification applies to the 28.6 inch-wide Color TFT-LCD Module G286HAN01.0. The display supports the 1/2 of Full HD - 1920(H) x 540(V) screen format and 16.7M colors (RGB 8-bits data). All input signals are dual channel LVDS interface.

LED driver board is not included. G286HAN01.0 is designed for industrial display applications.

### 2.1 Display Characteristics

The following items are characteristics summary on the table under 25 °C condition:

ITEMS	Unit	SPECIFICATIONS
Screen Diagonal	[mm]	726.44(28.6")
Active Area	[mm]	698.400 (H) x 196.425 (V)
Pixels H x V		1920(x3) x 540
Pixel Pitch	[um]	363.75 (per one triad) ×363.75
Pixel Arrangement		R.G.B. Vertical Stripe
Display Mode		VA Mode, Normally Black
White Luminance ( Center )	[cd/m <sup>2</sup> ]	1000
Contrast Ratio		1000: 1
Optical Response Time	[msec]	25
Nominal Input Voltage VDD	[Volt]	+12 V
Power Consumption	[Watt]	TBD
Weight	[g]	2,700 (typical)
Physical Size	[mm]	731.46(H) x 229.49(V) x 20.34(D) (Typ)
Electrical Interface		Dual channel LVDS
Support Color		16.7M colors (true 8-bit)
Surface Treatment		Anti-Glare, 3H
Temperature Range Operating Storage (Shipping)	[°C] [°C]	-10 to +60 -20 to +70
RoHS Compliance		RoHS Compliance

## 2.2 Optical Characteristics

The optical characteristics are measured under stable conditions at 25°C (Room Temperature):

Item	Unit	Conditions	Min.	Typ.	Max.	Note
White Luminance	[cd/m <sup>2</sup> ]	I <sub>F</sub> = 120mA	800	1000	-	1
Uniformity	%	9 Points	75	80	-	1, 2, 3
Contrast Ratio			800	1000	-	4
Cross talk	%		-	-	1.5	5
Response Time	[msec]	Rising	-	16	-	6
		Falling	-	9	-	
		Rising + Falling	-	25	-	
Viewing Angle	[degree] [degree]	Horizontal (Right) CR = 10 (Left)	75 75	89 89	- -	7
	[degree] [degree]	Vertical (Upper) CR = 10 (Lower)	75 75	89 89	- -	
Color / Chromaticity Coordinates (CIE 1931)		Red x	-0.05	TBD	+0.05	
		Red y		TBD		
		Green x		TBD		
		Green y		TBD		
		Blue x		TBD		
		Blue y		TBD		
		White x		0.313		
		White y		0.329		
Color Gamut	%			72	-	

Note 1: Measurement method

Equipment Pattern Generator, Power Supply, Digital Voltmeter, Luminance meter (SR\_3 or equivalent)

Aperture 1□ with 50cm viewing distance

Test Point Center

Environment < 1 lux

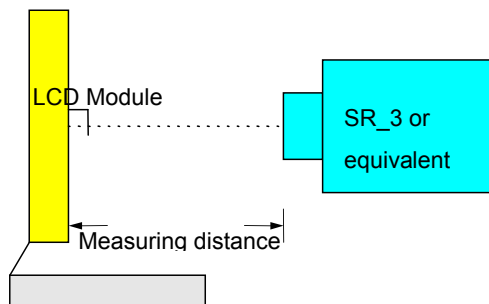

Note 2: Definition of 9 points position. Display active area:

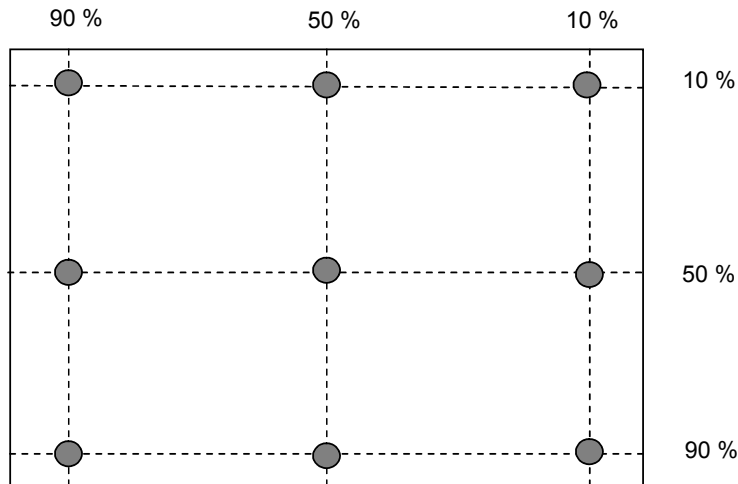

Note 3: The luminance uniformity of 9 points is defined by dividing the minimum luminance values by the maximum test point luminance

$$\delta_{w9} = \frac{\text{Minimum Brightness of nine points}}{\text{Maximum Brightness of nine points}}$$

Note 4 : Definition of contrast ratio (CR):

$$\text{Contrast ratio (CR)} = \frac{\text{Brightness on the "White" state}}{\text{Brightness on the "Black" state}}$$

Note 5 : Definition of cross talk (CT)

$$CT = |YB - YA| / YA \times 100 (\%)$$

Where

YA = Luminance of measured location without gray level 255 pattern (cd/m<sup>2</sup>)

YB = Luminance of measured location with gray level 255 pattern (cd/m<sup>2</sup>)

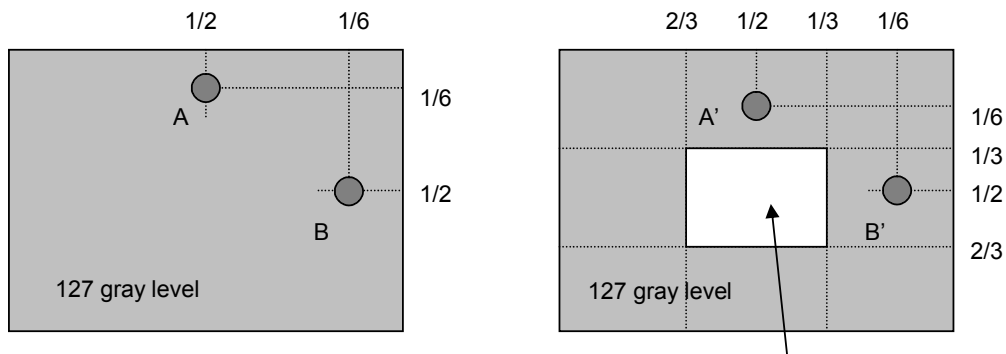

Note 6: Definition of response time:

The output signals of photo detector are measured when the input signals are changed from “White” to “Black” (falling time) and from “Black” to “White” (rising time), respectively. The response time interval is between 10% and 90% of amplitudes. Please refer to the figure as below.

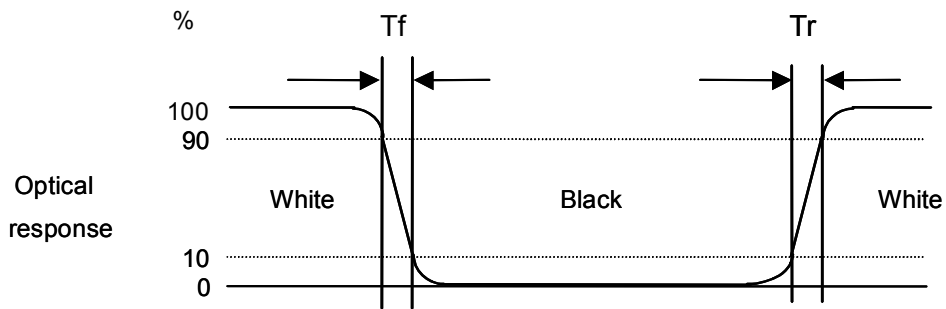

Note 7: Definition of viewing angle

Viewing angle is the measurement of contrast ratio  $\geq 10$ , at the screen center, over a 180° horizontal and 180° vertical range (off-normal viewing angles). The 180° viewing angle range is broken down as below: 90° ( $\theta$ ) horizontal left and right, and 90° ( $\phi$ ) vertical high (up) and low (down). The measurement direction is typically perpendicular to the display surface with the screen rotated to its center to develop the desired measurement viewing angle.

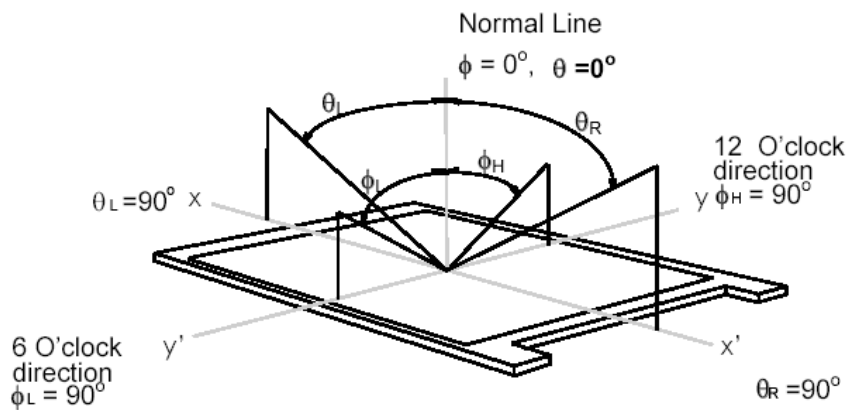



### 3. Functional Block Diagram

The following diagram shows the functional block of the 28.6 inches wide Color TFT-LCD Module:

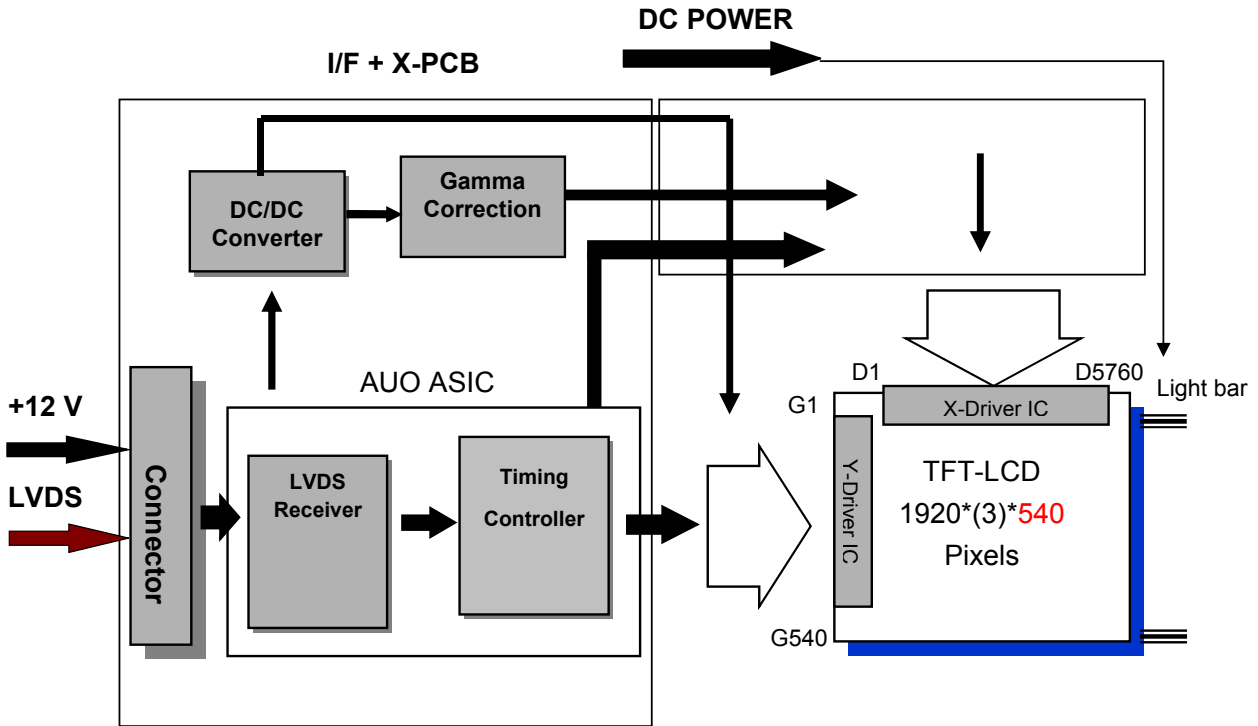

LVDS Connector: FCN CT110046-5133 or equivalent.  
 LED light bar Connector: ENTERY 3707K-S06N-01L or equivalent.



## 4. Absolute Maximum Ratings

### 4.1 TFT LCD Module

Item	Symbol	Min	Max	Unit	Conditions
Logic/LCD Drive Voltage	VDD	-0.3	13.2	[Volt]	<b>Note 1,2</b>

### 4.2 Backlight Unit

Item	Symbo	Min	Max	Unit	Conditions
LED LB Input Voltage	Vcc	TBD	TBD	[Volt]	<b>Note 1,2</b>

### 4.3 Absolute Ratings of Environment

Item	Symbol	Min.	Max.	Unit	Conditions
Operating Temperature	TOP	-10	60	[°C]	<b>Note 3</b>
Operation Humidity	HOP	5	90	[%RH]	
Storage Temperature	TST	-20	70	[°C]	
Storage Humidity	HST	5	90	[%RH]	

**Note 1:** With in Ta (25°C)

**Note 2:** Permanent damage to the device may occur if exceeding maximum values

**Note 3:** For quality performance, please refer to AUO IIS(Incoming Inspection Standard).

## 5. Electrical Characteristics

### 5.1 TFT LCD Module

#### 5.1.1 Power Specification

Symbol	Parameter	Min	Typ	Max	Units	Remark
VDD	Logic/LCD Drive Voltage	10.8	12	13.2	[Volt]	± 10%
IDD	VDD Current	-	TBD	TBD	[mA]	VDD= 5.0V, All White Pattern At 60Hz
Irush	LCD Inrush Current	-	-	TBD	[A]	Note 1
PDD	VDD Power	-	TBD	TBD	[Watt]	VDD= 5.0V, All White Pattern At 60Hz

Note 1: Measurement condition:

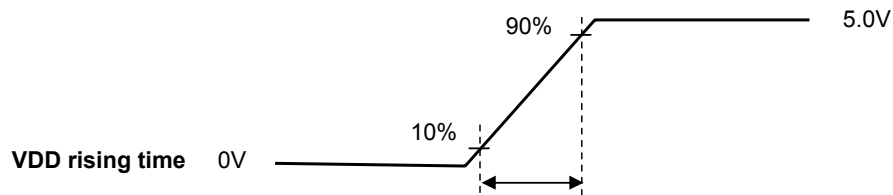
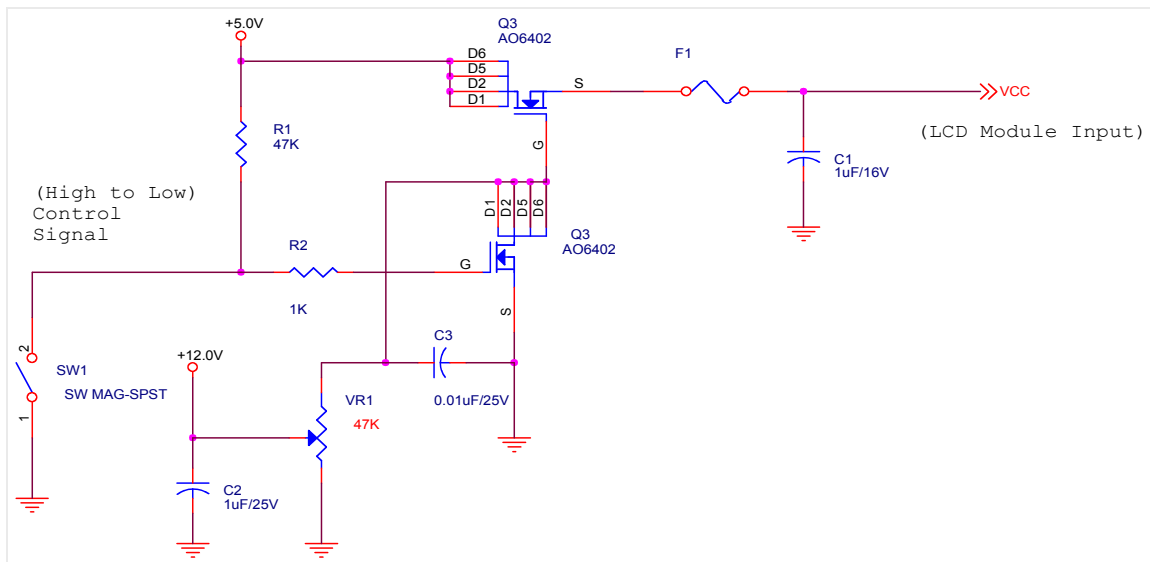

## 5.1.2 Signal Electrical Characteristics

Input signals shall be low or Hi-Z state when VDD is off.

Symbol	Item	Min.	Typ.	Max.	Unit	Remark
V <sub>TH</sub>	Differential Input High Threshold	-	-	100	[mV]	V <sub>CM</sub> =1.2V
V <sub>TL</sub>	Differential Input Low Threshold	-100	-	-	[mV]	V <sub>CM</sub> =1.2V
VID	Input Differential Voltage	100	400	600	[mV]	
V <sub>ICM</sub>	Differential Input Common Mode Voltage	0.3	-	1.25	[V]	V <sub>TH</sub> /V <sub>TL</sub> =±100mV

Note: LVDS Signal Waveform.

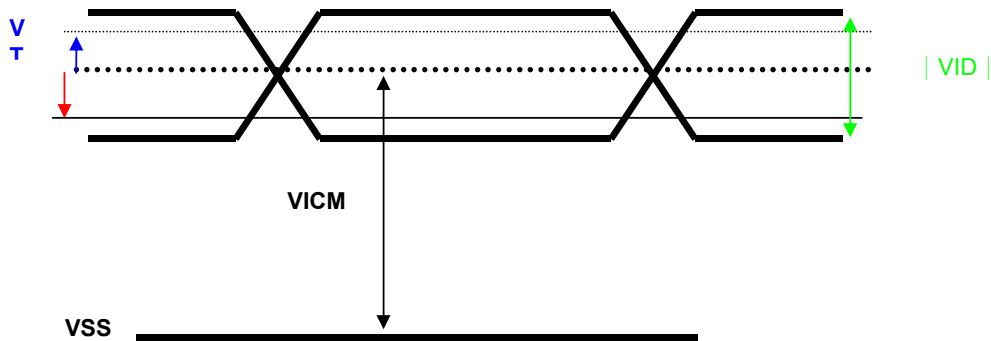



## 5.2 Backlight Unit

### 5.2.1 LED Light Bar

Following characteristics are measured under stable condition at 25°C (Room Temperature).

Symbol	Parameter	Min.	Typ.	Max.	Unit	Remark
I <sub>F</sub>	LED Forward Current		120		mA	Ta = 25°C
V <sub>F LED</sub>	Forward Voltage		TBD		Volt	Ta = 25°C
P <sub>LED</sub>	LED Power Consumption	-	TBD		Watt	Ta = 25°C, Note 3
LTLED	LED Life Time	50,000			Hrs	Ta = 25°C, Note 4

**6. Signal Characteristic**

**6.1 Pixel Format Image**

Following figure shows the relationship of the input signals and LCD pixel format.

	1			2			...						1919			1920		
1st Line	R	G	B	R	G	B	.....						R	G	B	R	G	B
	.	.	.	.	.	.	.						.	.	.	.	.	.
	.	.	.	.	.	.	.						.	.	.	.	.	.
	.	.	.	.	.	.	.						.	.	.	.	.	.
	.	.	.	.	.	.	.						.	.	.	.	.	.
	.	.	.	.	.	.	.						.	.	.	.	.	.
	.	.	.	.	.	.	.						.	.	.	.	.	.
	.	.	.	.	.	.	.						.	.	.	.	.	.
	.	.	.	.	.	.	.						.	.	.	.	.	.
	.	.	.	.	.	.	.						.	.	.	.	.	.
	.	.	.	.	.	.	.						.	.	.	.	.	.
540 Line	R	G	B	R	G	B	.....						R	G	B	R	G	B



## 6.2 Signal Description

The module using a pair of LVDS receiver SN75LVDS82(Texas Instruments) or compatible. LVDS is a differential signal technology for LCD interface and high speed data transfer device. Transmitter shall be SN75LVDS83(negative edge sampling) or compatible. The first LVDS port transmits odd pixels while the second LVDS port transmits even pixels.

PIN #	SIGNAL NAME	DESCRIPTION
1	N.C.	No Connection
2	N.C.	No Connection
3	N.C.	No Connection
4	N.C.	No Connection
5	N.C.	No Connection
6	N.C.	No Connection
7	SELLVDS	LVDS data format Selection
8	N.C.	No Connection
9	N.C.	No Connection
10	N.C.	No Connection
11	GND	Power Ground
12	RXinO0-	Negative LVDS differential data input (Odd data)
13	RXinO0+	Positive LVDS differential data input (Odd data)
14	RXinO1-	Negative LVDS differential data input (Odd data)
15	RXinO1+	Positive LVDS differential data input (Odd data)
16	RXinO2-	Negative LVDS differential data input (Odd data, H-Sync, V-Sync, DSPTMG)
17	RXinO2+	Positive LVDS differential data input (Odd data, H-Sync, V-Sync, DSPTMG)
18	GND	Power Ground
19	RxOCLKIN-	Negative LVDS differential clock input (Odd clock)
20	RxOCLKIN+	Positive LVDS differential clock input (Odd clock)
21	GND	
22	RXinO3-	Negative LVDS differential data input (Odd data)
23	RXinO3+	Positive LVDS differential data input (Odd data)
24	N.C.	No contact (For AUO test only)
25	N.C.	No contact (For AUO test only)
26	N.C.	No contact (For AUO test only)
27	N.C.	No contact (For AUO test only)
28	RXinE0-	Negative LVDS differential data input (Even data)
29	RXinE0+	Positive LVDS differential data input (Even data)
30	RXinE1-	Negative LVDS differential data input (Even data)



# Product Specification

G286HAN01.0

AU OPTRONICS CORPORATION

31	RXinE1+	Positive LVDS differential data input (Even data)
32	RXinE2-	Negative LVDS differential data input (Even data)
33	RXinE2+	Positive LVDS differential data input (Even data)
34	GND	
35	RxECLKIN-	Negative LVDS differential clock input (Even clock)
36	RxECLKIN+	Positive LVDS differential clock input (Even clock)
37	GND	
38	RXinE3-	Negative LVDS differential data input (Even data)
39	RXinE3+	Positive LVDS differential data input (Even data)
40	N.C.	No Connection
41	N.C.	No Connection
42	GND	Ground
43	GND	Ground
44	GND	Ground
45	GND	Ground
46	GND	Ground
47	N.C.	No Connection
48	VDD	Power +12V
49	VDD	Power +12V
50	VDD	Power +12V
51	VDD	Power +12V



### 6.3 The Input Data Format

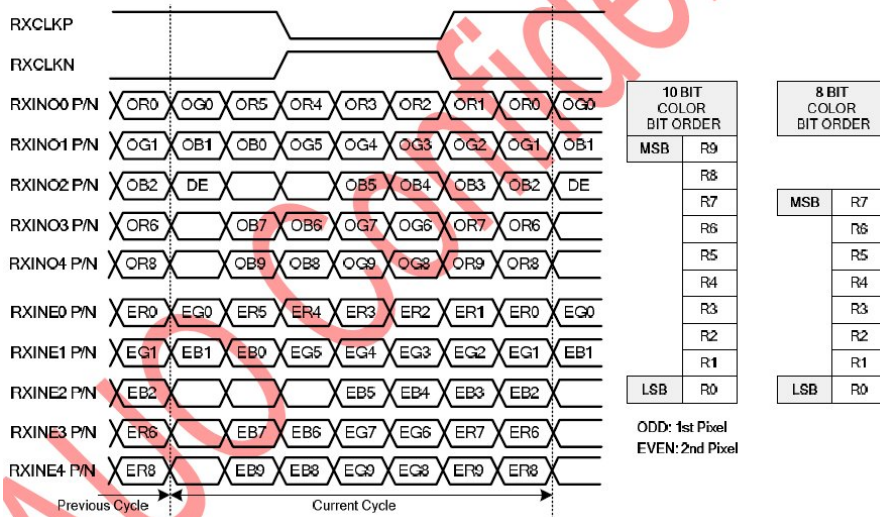

Data Mapping of VESA Format

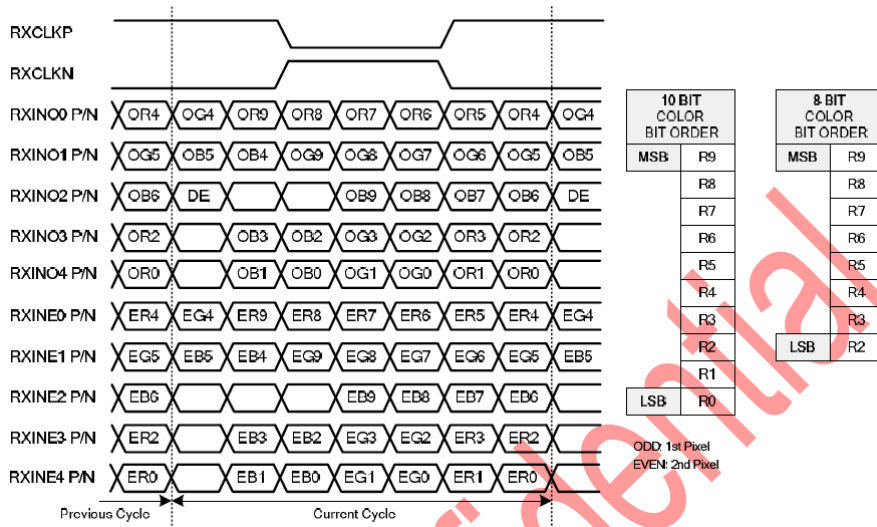

## 6.4 Interface Timing

### 6.4.1 Timing Characteristics

Signal	Item	Symbol	Min	Typ	Max	Unit
Clock	Frequency	$1/T_{\text{Clock}}$	TBD	91	TBD	MHz
Frame Rate	Frequency	$1/T_v$	50	60	75	Hz
Vertical Section	Period	$T_v$	TBD	585	TBD	T_line
	Active	$T_{vD}$	TBD	540	TBD	
	Blanking	$T_{vB}$	TBD	45	TBD	
Horizontal Section	Period	$T_H$	TBD	1283	TBD	T_clock
	Active	$T_{HD}$	TBD	960	TBD	
	Blanking	$T_{HB}$	TBD	323	TBD	

Note: DE mode only.

### 6.4.2 Input Timing Diagram

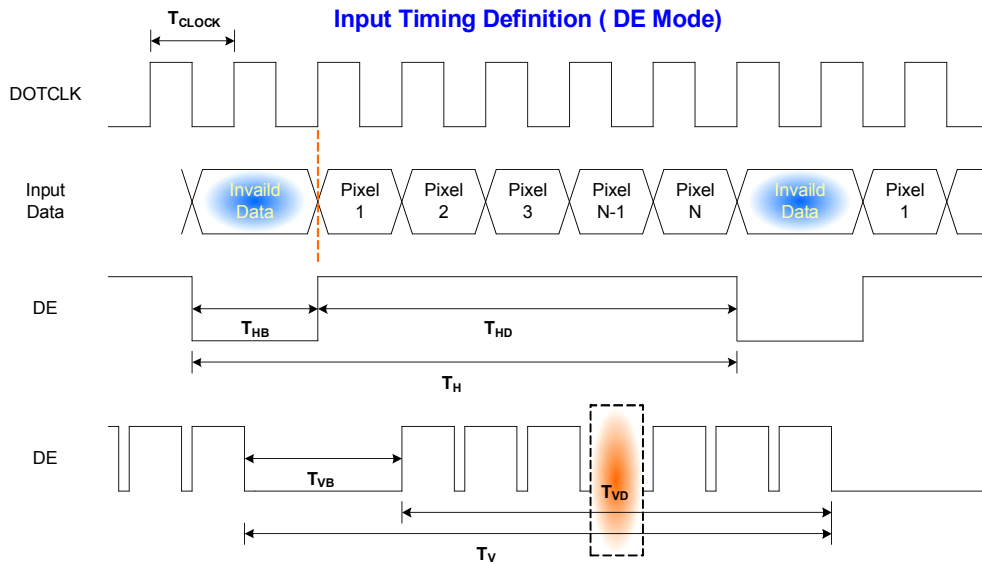

## 6.5 Power ON/OFF Sequence

VDD power on/off sequence is as follows. Interface signals are also shown in the chart. Signals from any system shall be Hi-Z state or low level when VDD is off.

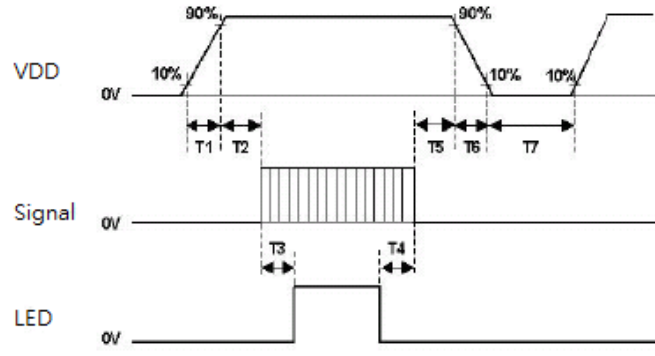

Power Sequence Timing			
Parameter	Value		Units
	Min.	Max.	
T1	0.5	10	ms
T2	30	50	
T3	200	-	
T4	200	-	
T5	0	50	
T6	0	10	
T7	1000	-	

The above on/off sequence should be applied to avoid abnormal function in the display. Please make sure to turn off the power when you plug the cable into the input connector or pull the cable out of the connector.

## 7. Connector & Pin Assignment

Physical interface is described as for the connector on module. These connectors are capable of accommodating the following signals and will be following components.

### 7.1 TFT LCD Module: LVDS Connector

Connector Name / Designation	Interface Connector / Interface card
Manufacturer	FCN
Type Part Number	CT110046-5133 or equivalent.
Mating Housing Part Number	JAE FI-RE51S-HF or compatible

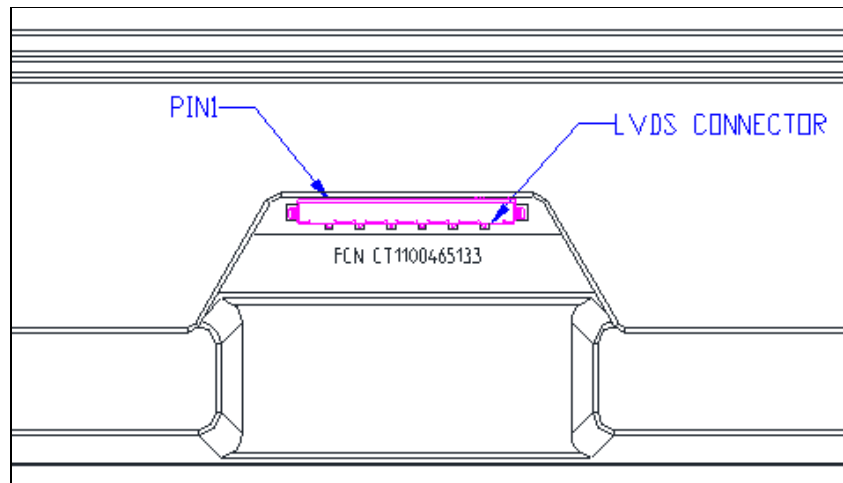

## 7.2 Backlight Unit: LED Light Bar Connector

Connector Name / Designation	LED Connector
Manufacturer	ENTERY
Connector Model Number	ENTERY 3707K-S06N-01L
Mating Housing Part Number	ENTERY H112K-D06N-21B or compatible

PIN #	SIGNAL NAME	DESCRIPTION
1	VLED+	Positive of LED String
2	VLED+	
3	N1	Negative of LED String
4	N2	
5	N3	
6	N4	

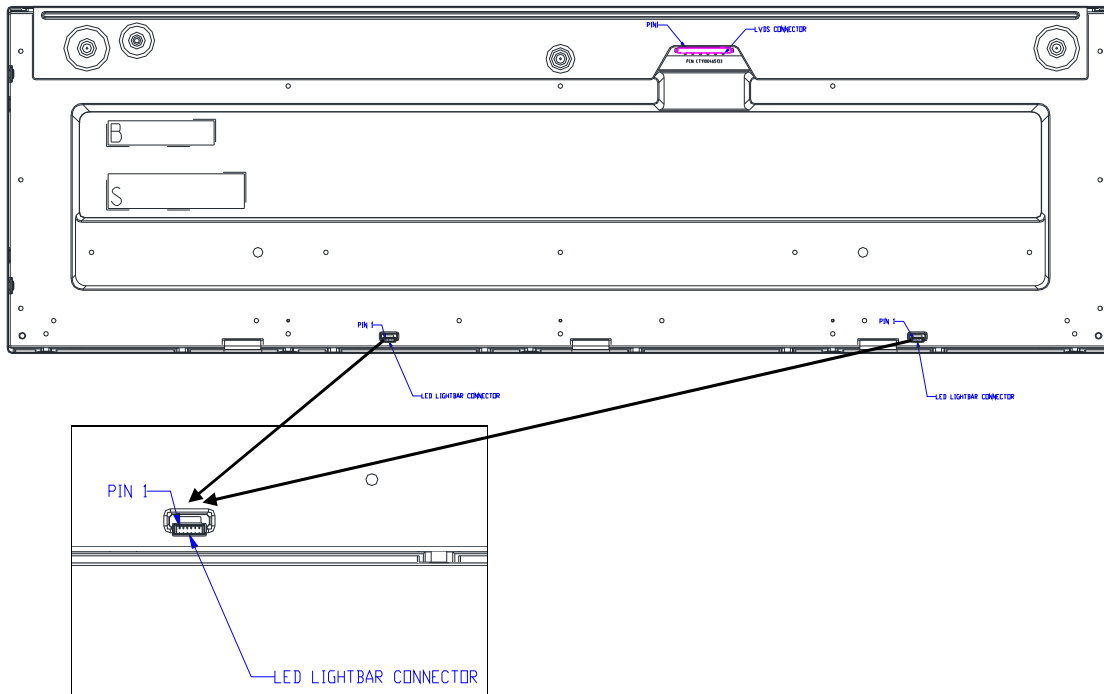



### 8. Reliability Test

Environment test conditions are listed as following table.

Items	Required Condition	Note
Temperature Humidity Bias (THB)	Ta= 60□, 80%RH, 300hours	
High Temperature Operation (HTO)	Ta= 60□, 50%RH, 300hours	
Low Temperature Operation (LTO)	Ta= -10□, 300hours	
High Temperature Storage (HTS)	Ta= 70□, 300hours	
Low Temperature Storage (LTS)	Ta= -20□, 300hours	
Vibration Test (Non-operation)	Acceleration: 1.5 Grms Wave: Random Frequency: 10 - 200 Hz Duration: 30 Minutes each Axis (X, Y, Z)	
Shock Test (Non-operation)	Acceleration: 50 G Wave: Half-sine Active Time: 20 ms Direction: ±X, ±Y, ±Z (one time for each Axis)	
Drop Test	Height: 46 cm, package test	
Thermal Shock Test (TST)	-20□/30min, 60□/30min, 100 cycles	
On/Off Test	On/10sec, Off/10sec, 30,000 cycles	
ESD (Electro Static Discharge)	Contact Discharge: ± 8KV, 150pF(330Ω ) 1sec, 8 points, 25 times/ point.	1
	Air Discharge: ± 15KV, 150pF(330Ω ) 1sec 8 points, 25 times/ point.	
Altitude Test	Operation:10,000 ft Non-Operation:30,000 ft	

Note 1: According to EN61000-4-2, ESD class B: Some performance degradation allowed. No data lost

Self-recoverable. No hardware failures.

Note2:

- Water condensation is not allowed for each test items.
- Each test is done by new TFT-LCD module. Don't use the same TFT-LCD module repeatedly for reliability test.
- The reliability test is performed only to examine the TFT-LCD module capability.
- To inspect TFT-LCD module after reliability test, please store it at room temperature and room humidity for 24 hours at least in advance.
- No function failure occurs.



## 10. Label and Packaging

### 10.1 Shipping Label (on the rear side of TFT-LCD display)

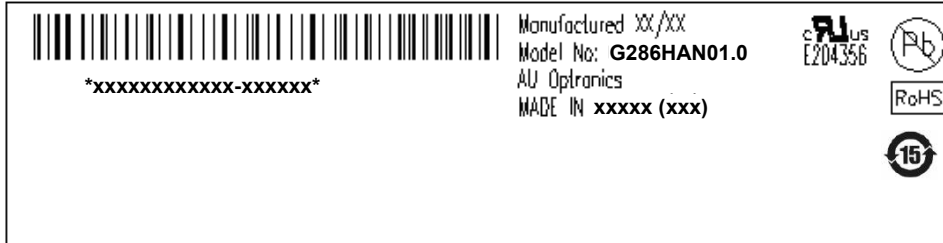

### 10.2 Carton Package

- The outside dimension of carton is 810 x 210x 430 (mm).
- 4 pieces per carton box.
- 1\*5 boxes per layer. By air, 3 layer / pallet. By sea, refer packing documents. Pallet size (not include carton boxes): 1150 mm \* 840 mm \* 135 mm

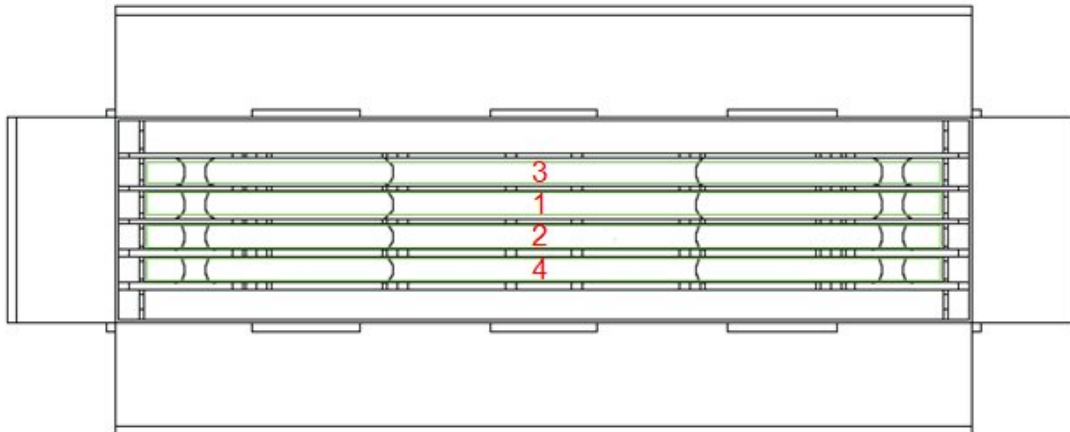





## 11. Safety

### 11.1 Sharp Edge Requirements

There will be no sharp edges or comers on the display assembly that could cause injury.

### 11.2 Materials

#### 11.2.1 Toxicity

There will be no carcinogenic materials used anywhere in the display module. If toxic materials are used, they will be reviewed and approved by the responsible AUO toxicologist.

#### 11.2.2 Flammability

All components including electrical components that do not meet the flammability grade UL94-V1 in the module will complete the flammability rating exception approval process.

The printed circuit board will be made from material rated 94-V1 or better. The actual UL flammability rating will be printed on the printed circuit board.

### 11.3 Capacitors

If any polarized capacitors are used in the display assembly, provisions will be made to keep them from being inserted backwards.

### 11.4 National Test Lab Requirement

The display module will satisfy all requirements for compliance to:

UL 1950, First Edition

U.S.A. Information Technology Equipment