

G2N7000

N-CHANNEL ENHANCEMENT MODE MOSFET

Description

The G2N7000 is designed for high voltage, high speed applications such as switching regulators, converters, solenoid and relay drivers.

Package Dimensions

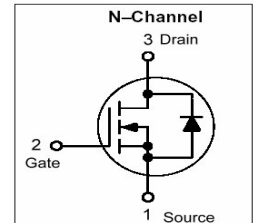
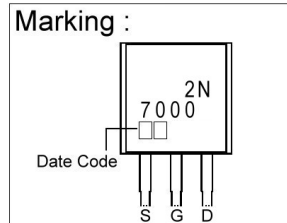
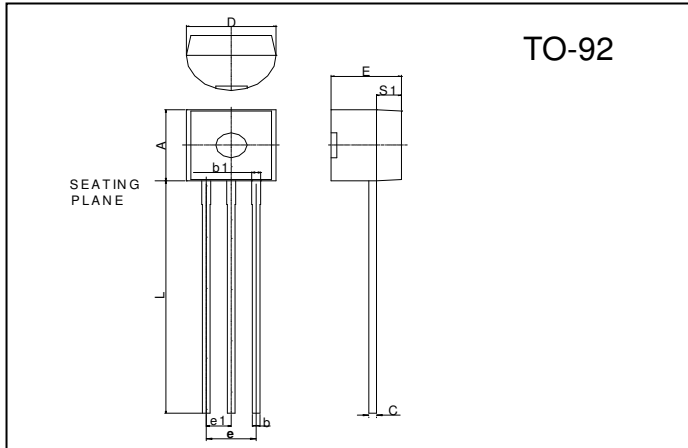

REF.	Millimeter		REF.	Millimeter	
	Min.	Max.		Min.	Max.
A	4.45	4.7	D	4.44	4.7
S1	1.02	-	E	3.30	3.81
b	0.36	0.51	L	12.70	-
b1	0.36	0.76	e1	1.150	1.390
C	0.36	0.51	e	2.42	2.66

Absolute Maximum Ratings at Ta = 25°C

Parameter	Symbol	Ratings	Unit	
Operating Junction and Storage Temperature Range	Tj, Tstg	-55 ~ +150	°C	
Drain-Source Voltage	Vdss	60	V	
Gate-Source Voltage	Vgs	±20	V	
-Continuous	Vgsm	±40	V	
-Non-repetitive (tp ≤ 50us)				
Drain Current	Id	200	mA	
-Continuous				
- Pulsed	Idm	500		
Power Dissipation	Pd	Ta=25°C	0.35	W
		Derate above 25°C	2.8	
Thermal Resistance ,Junction-to-Ambient	RθJA	357	°C/W	
Maximum Lead Temperature for Soldering Purposes, 1/16" from case for 10 seconds	Tl	300	°C	

Electrical Characteristics (Tc= 25°C unless otherwise noted)

Parameter	Symbol	Min.	Typ.	Max.	Unit	Test Conditions
Drain-Source Breakdown Voltage	V(BR)DSS	60	-	-	V	VGS=0, ID=250uA
Gate Threshold Voltage	VGS(th)	0.8	-	3.0	V	VDS= VGS, ID=1.0mA
Gate Body Leakage Current	IGSS	-	-	±100	nA	VGS=±20V, VDS=0
Zero Gate Voltage Drain Current	IDSS	-	-	1	uA	VDS=60V, VGS=0
On-State Drain Current	ID(ON)	75	-	-	mA	VGS=4.5V, VDS=10V
Static Drain-Source on-State Resistance	RDS(ON)	-	-	5.0	Ω	VGS=10V, ID=500mA
		-	-	6.0		VGS=4.5V, ID=75mA
Drain-Source on-Voltage	VDS(ON)	-	-	2.5	V	VGS=10V, ID=500mA
		-	-	0.45		VGS=4.5V, ID=75mA
Forward Transconductance	GFS	100	-	-	mS	VDS=10 V, ID=200mA
Input Capacitance	Ciss	-	-	60	pF	VDS=25V, VGS=0V, f=1MHz
Output Capacitance	Coss	-	-	25		
Reverse Transfer Capacitance	Crss	-	-	5		

Switching Characteristics (Note 1)

Turn-on Delay Time	t_{on}	-	-	10	ns	$V_{DD}=15V, I_D=500mA$ $R_G=25\Omega, R_L=30\Omega, V_{gen}=10V$
Turn-off Delay Time	t_{off}	-	-	10		

Note 1. Pulse Test: Pulse Width $\leq 300\mu s$, Duty cycle $\leq 2\%$.

Characteristics Curve

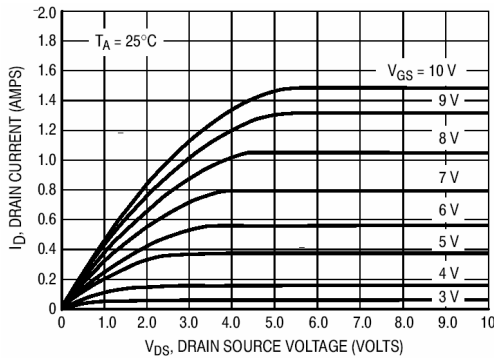

Figure 1. Ohmic Region

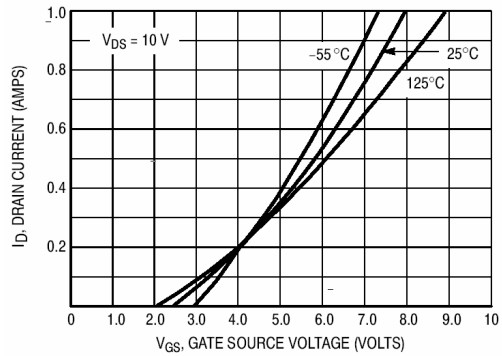

Figure 2. Transfer Characteristics

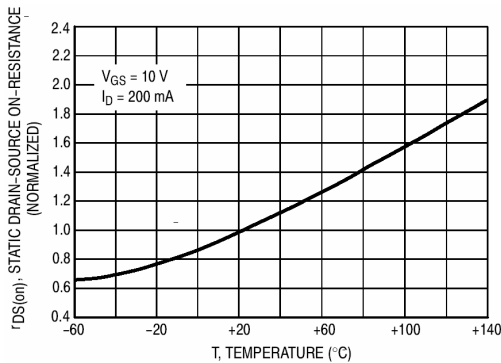

Figure 3. Temperature versus Static Drain-Source On-Resistance

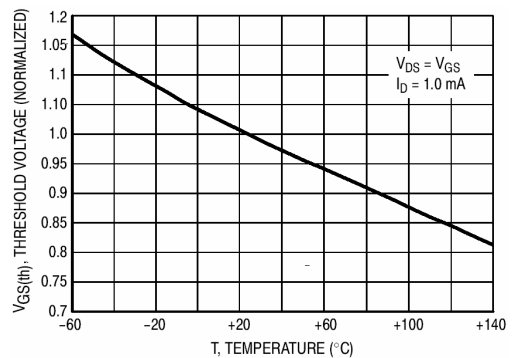

Figure 4. Temperature versus Gate Threshold Voltage

Important Notice:

- All rights are reserved. Reproduction in whole or in part is prohibited without the prior written approval of GTM.
- GTM reserves the right to make changes to its products without notice.
- GTM semiconductor products are not warranted to be suitable for use in life-support Applications, or systems.
- GTM assumes no liability for any consequence of customer product design, infringement of patents, or application assistance.

Head Office And Factory:

- Taiwan:** No. 17-1 Tatung Rd. Fu Kou Hsin-Chu Industrial Park, Hsin-Chu, Taiwan, R. O. C.
- TEL : 886-3-597-7061 FAX : 886-3-597-9220, 597-0785
- China:** (201203) No.255, Jang-Jiang Tsai-Lueng RD. , Pu-Dung-Hsin District, Shang-Hai City, China
- TEL : 86-21-5895-7671 ~ 4 FAX : 86-21-38950165