



Product Specification

G320ZAN01.0

AU OPTRONICS CORPORATION

(v) Preliminary Specifications

() Final Specifications

Module	32 Inch Color TFT-LCD
Model Name	G320ZAN01.0

Customer	Date
_____	_____
Checked & Approved by	Date
_____	_____
Customer's sign back page	

Approved by	Date
<u><i>Crystal Hsieh</i></u>	<u>2017/09/01</u>
Prepared by	Date
<u><i>Wennie Lee</i></u>	<u>2017/09/01</u>
General Display Business Unit / AU Optronics corporation	



Contents

1. Operating Precautions4

2. General Description5

 2.1 Display Characteristics..... 5

 2.2 Optical Characteristics6

3. Functional Block Diagram.....9

4. Absolute Maximum Ratings10

 4.1 Absolute Ratings of TFT LCD Module..... 10

 4.2 Absolute Ratings of Environment..... 10

5. Electrical Characteristics11

 5.1 TFT LCD Module 11

 5.2 Backlight Unit..... 12

6. Signal Characteristic14

 6.1 Pixel Format Image..... 14

 6.2 Scanning Direction..... 14

 6.3 Signal Description 15

 6.4 The Input Data Format..... 17

 6.5 Interface Timing 20

 6.6 Power ON/OFF Sequence 23

7. Reliability Test Criteria24

8. Mechanical Characteristics25

 8.1 LCM Outline Dimension 25

9. Label and Packaging27

 9.1 Shipping Label (on the rear side of TFT-LCD display)..... 27

 9.2 Carton Package 27

10 Safety28

 10.1 Sharp Edge Requirements..... 28

 10.2 Materials 28

 10.3 Capacitors..... 28

 10.4 National Test Lab Requirement..... 28



Product Specification

G320ZAN01.0

AU OPTRONICS CORPORATION

Record of Revision

Version	Date	Page	Old description	New Description
0.1	2016/12/27	All	First draft specification	
0.2	2017/9/1	5	Power Consumption: Logic: max. 15.6 W@ white pattern; BL power: max. 120.96 W	Logic: max. 17.28 W@ white pattern BL power: max. 110.08 W
			Weight: 5200	4630g +/- 10%
		6	Contrast Ratio: 700(min), 1000(typ)	800(min), 1350(typ)
				Add response time
		11	IDD: 1.08(typ); 1.30(max)	1.2(typ); 1.44(max)
			PDD: 12.96(typ); 15.6(max)	14.4(typ); 17.28(max)
			Irush: TBD	4
		12	Pin 13: SEL	NC
			Pin 14: E_PWM: Hi Level: 3.3V	Hi Level: 3V
				Add note
		13	PLED: 92.2(typ), 104.4(max)	82.56(typ): 93.57(max)
			I _{VDD} : 4.2(typ); 5.04(max)	4.05(typ); 4.59(max)
			P _{VDD} : 100.8(typ); 120.96(max)	97.13(typ); 110.08(max)
			Swing Voltage: 3.3(typ)	3(typ)
			I _{F (one channel)} : 120(typ)	107.5(typ)
		24	Vibration Test: 1.5G, 10~200~10Hz, Sine wave; 30mins/axis, 3 direction (X, Y, Z)	1.0G, 10~300Hz, Random wave 10mins/axis, 3 direction (X, Y, Z)



1. Operating Precautions

- 1) Since front polarizer is easily damaged, please be cautious and not to scratch it.
- 2) Be sure to turn off power supply when inserting or disconnecting from input connector.
- 3) Wipe off water drop immediately. Long contact with water may cause discoloration or spots.
- 4) When the panel surface is soiled, wipe it with absorbent cotton or soft cloth.
- 5) Since the panel is made of glass, it may be broken or cracked if dropped or bumped on hard surface.
- 6) To avoid ESD (Electro Static Discharge) damage, be sure to ground yourself before handling TFT-LCD Module.
- 7) Do not open nor modify the module assembly.
- 8) Do not press the reflector sheet at the back of the module to any direction.
- 9) In case if a module has to be put back into the packing container slot after it was taken out from the container, do not press the center of the LED light bar edge. Instead, press at the far ends of the LED light bar edge softly. Otherwise the TFT Module may be damaged.
- 10) At the insertion or removal of the Signal Interface Connector, be sure not to rotate nor tilt the Interface Connector of the TFT Module.
- 11) TFT-LCD Module is not allowed to be twisted & bent even force is added on module in a very short time. Please design your display product well to avoid external force applying to module by end-user directly.
- 12) Small amount of materials having no flammability grade is used in the LCD module. The LCD module should be supplied by power complied with requirements of Limited Power Source (IEC60950 or UL1950), or be applied exemption.
- 13) Severe temperature condition may result in different luminance, response time and lamp ignition voltage.
- 14) Continuous operating TFT-LCD display under low temperature environment may accelerate lamp exhaustion and reduce luminance dramatically.
- 15) The data on this specification sheet is applicable when LCD module is placed in landscape position.
- 16) Continuous displaying fixed pattern may induce image sticking. It's recommended to use screen saver or shuffle content periodically if fixed pattern is displayed on the screen.



2. General Description

This specification applies to the Color Active Matrix Liquid Crystal Display G320ZAN01.0 composed of a TFT-LCD display, a driver and power supply circuit, and a LED backlight system. The screen format is intended to support the UHD (3840(H)x2160(V)) screen and 1.07B colors. All input signals are V by one interface compatible. LED driving board for backlight unit is included in G320ZAN01.0.

2.1 Display Characteristics

The following items are characteristics summary on the table under 25 °C condition:

Items	Unit	Specifications
Screen Diagonal	[inch]	32.0" (812.8mm)
Active Area	[mm]	708.48 (H) x 398.52 (V)
Resolution		3840(x3) x 2160
Pixel Pitch	[mm]	0.1845 (per one triad) x 0.1845
Pixel Arrangement		R.G.B. Vertical Stripe
Display Mode		Normally Black, AHVA
Nominal Input Voltage VDD	[Volt]	+12.0 V
Power Consumption	[Watt]	Logic: max. 17.28 W@ white pattern BL power: max. 110.08 W
Weight	[Grams]	4630g +/- 10%
Physical Size	[mm]	727.3 (H) x 424.5 (V) x 20.48 (D) (Typ)
Electrical Interface		V by one
Surface Treatment		Anti-Glare treatment
Support Color		10bit(8bit+FRC)
Temperature Range (T surface)		
Operating	[°C]	0 to +50
Storage (Non-Operating)	[°C]	-20 to +60
RoHS Compliance		Yes

2.2 Optical Characteristics

The optical characteristics are measured under stable conditions(warm up 30 mins) at 25°C (Room Temperature):

Item	Unit	Conditions	Min.	Typ.	Max.	Note
White Luminance	cd/m ²	ILED=107.5mA(center point)	(600)	700	---	1
Uniformity	%	9 points	80	---	---	2,3
Contrast Ratio	--		800	1350		4
Response Time	msec	Rising	-	8	20	5
		Falling		10	20	
		Rising + Falling		18	40	
Viewing Angle	degree	Horizontal CR >= 10	(Right)	75	89	6
			(Left)	75	89	
		Vertical CR >= 10	(Upper)	75	89	
			(Lower)	75	89	
Color / Chromaticity Coordinates (CIE 1931)	--	Red x	0.655	0.685	0.715	
		Red y	0.279	0.309	0.339	
		Green x	0.180	0.210	0.240	
		Green y	0.680	0.710	0.740	
		Blue x	0.120	0.150	0.180	
		Blue y	0.030	0.060	0.090	
		White x	0.283	0.313	0.343	
		White y	0.299	0.329	0.359	
Adobe RGB coverage ratio	%		---	100	---	

Note 1: Measurement method

Equipment Pattern Generator, Power Supply, Digital Voltmeter, Luminance meter (SR_3 or equivalent)

Aperture 1° with 50cm viewing distance

Test Point Center

Environment < 1 lux

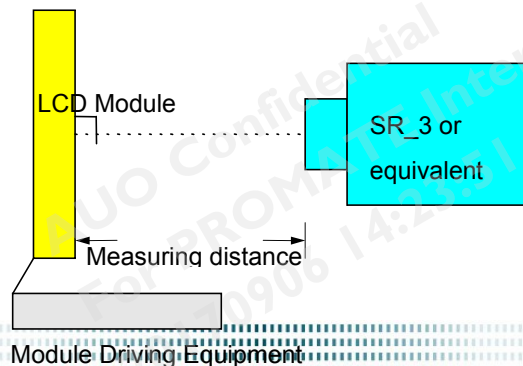

Note 2: Definition of 9 points position

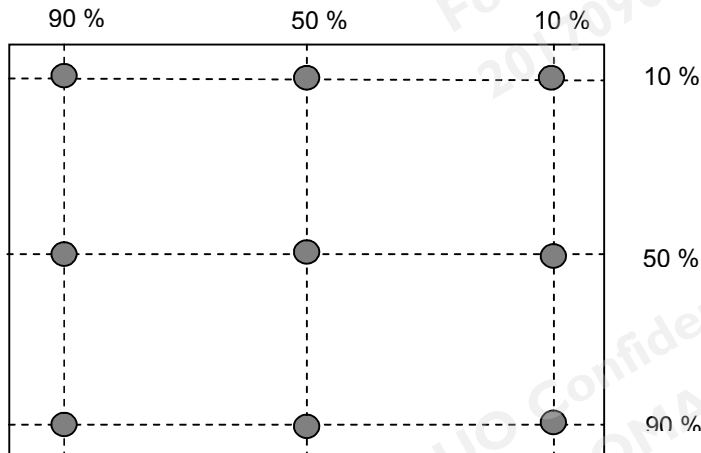

Note 3: The luminance uniformity of 9 points is defined by dividing the minimum luminance values by the maximum test point luminance

$$\delta_{w9} = \frac{\text{Minimum Brightness of nine points}}{\text{Maximum Brightness of nine points}}$$

Note 4: Definition of contrast ratio (CR):

$$\text{Contrast ratio (CR)} = \frac{\text{Brightness on the "White" state}}{\text{Brightness on the "Black" state}}$$

Note 5: Definition of response time:

The output signals of photo detector are measured when the input signals are changed from "White" to "Black" (falling time) and from "Black" to "White" (rising time), respectively. The response time interval is between 10% and 90% of amplitudes. Please refer to the figure as below.

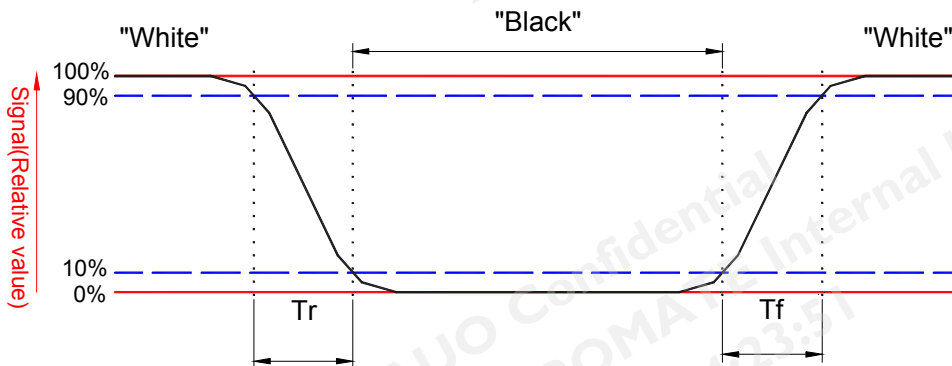

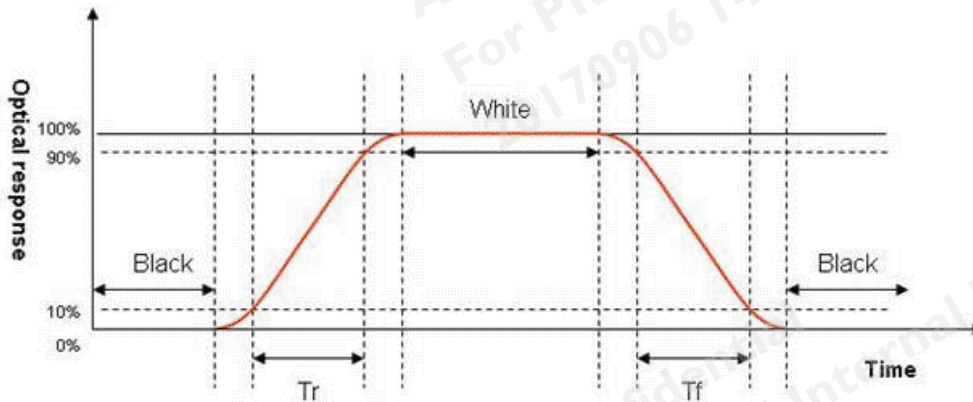

Note 6: Definition of viewing angle

Viewing angle is the measurement of contrast ratio ≥ 10 , at the screen center, over a 180° horizontal and 180° vertical range (off-normal viewing angles). The 180° viewing angle range is broken down as below: 90° (θ) horizontal left and right, and 90° (ϕ) vertical high (up) and low (down). The measurement direction is typically perpendicular to the display surface with the screen rotated to its center to develop the desired measurement viewing angle.

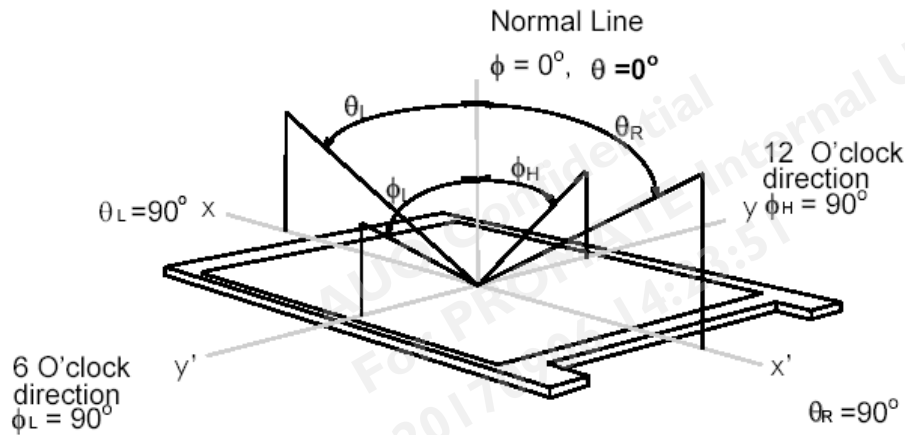

3. Functional Block Diagram

The following diagram shows the functional block of the 32 inch color TFT/LCD module:

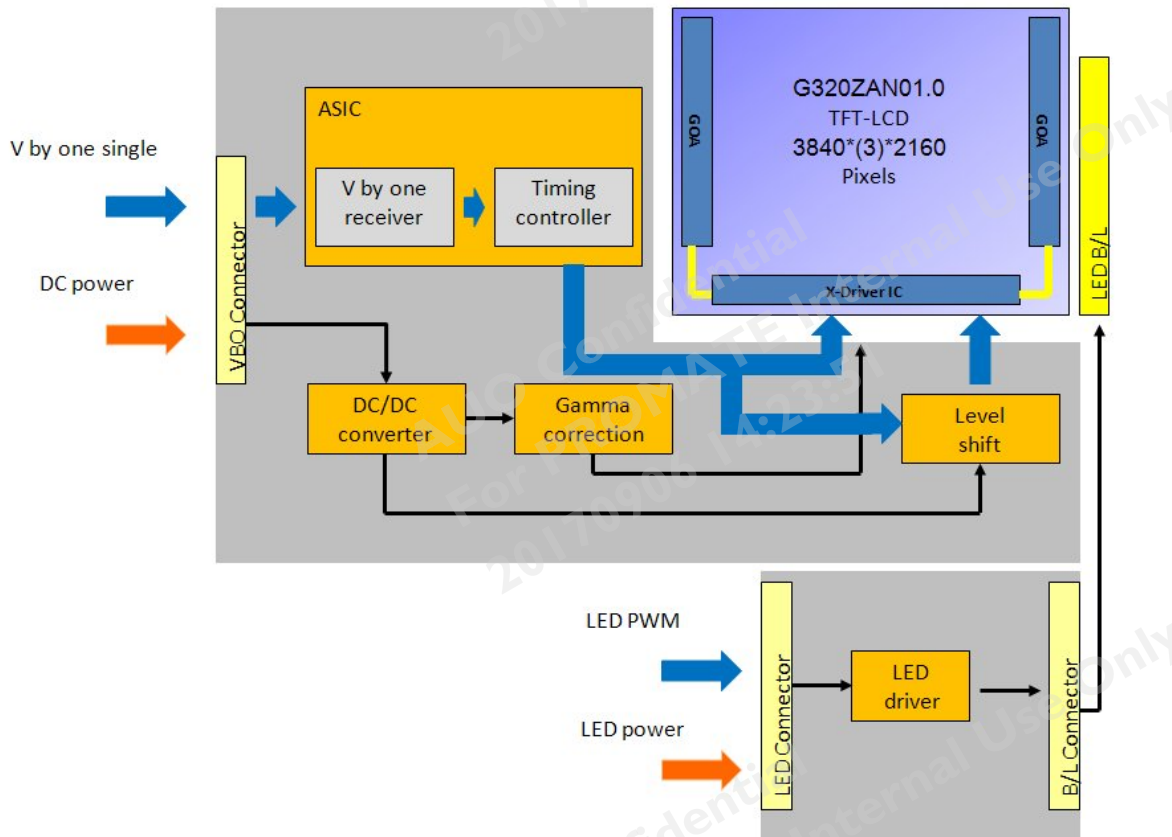

I/F PCB Interface:

FI-RE51S-HF

Mating Type:

FI-RE51HL

4. Absolute Maximum Ratings

4.1 Absolute Ratings of TFT LCD Module

Item	Symbol	Min	Max	Unit
Logic/LCD drive Voltage	Vin	-0.3	+16.5	[Volt]

4.2 Absolute Ratings of Environment

Item	Symbol	Min	Max	Unit
Operating Temperature	TOP	0	+50	[°C]
Operation Humidity	HOP	5	90	[%RH]
Storage Temperature	TST	-20	+60	[°C]
Storage Humidity	HST	5	90	[%RH]

Note: temperature is defined as surface temperature

Note: Maximum Wet-Bulb should be 39°C and no condensation.

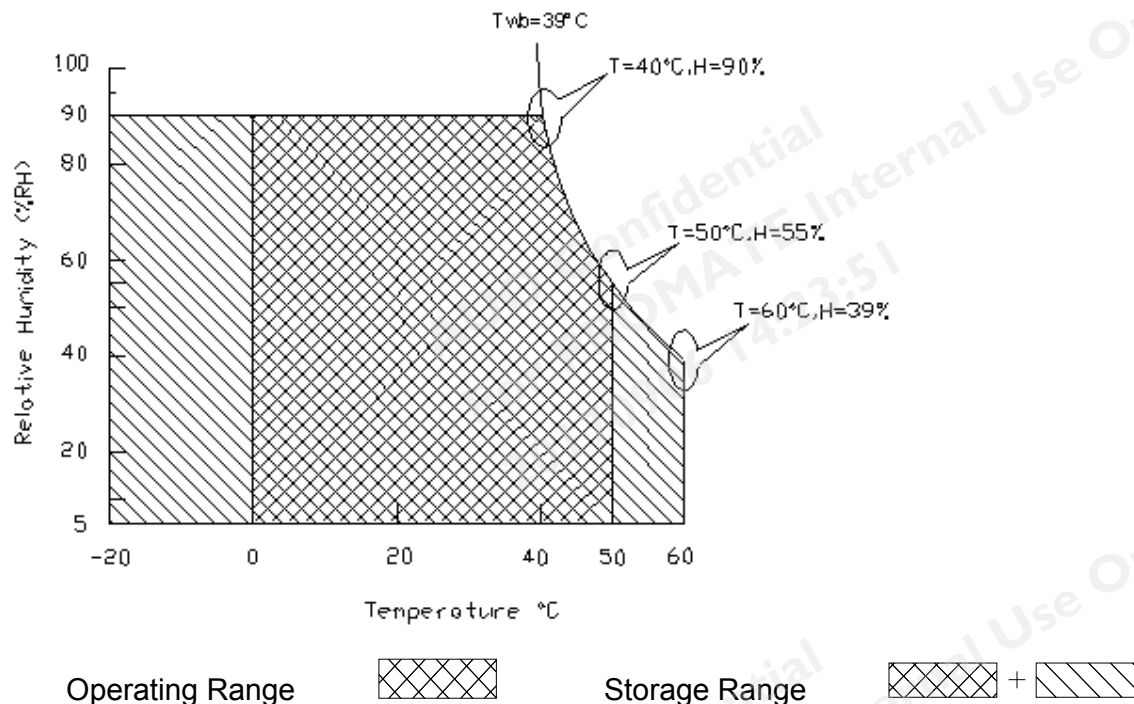

5. Electrical Characteristics

5.1 TFT LCD Module

5.1.1 Power Specification

Input power specifications are shown as follows;

Symbol	Parameter	Min	Typ	Max	Units	Remark
VDD	Logic/LCD Drive Voltage	10.8	12.0	13.2	[Volt]	±10%
IDD	VDD Current	-	1.2	1.44	[mA]	White Pattern (VDD=12V, at 60Hz)
Irush	LCD Inrush Current	-	-	4	[A]	Note 1 (VDD=12V, at 60Hz)
PDD	VDD Power	-	14.4	17.28	[Watt]	White Pattern (VDD=12V, at 60Hz)
VDDrp	Allowable Logic/LCD Drive Ripple Voltage	-	-	VDD* 5%	[mV]	White Pattern (VDD=12V, at 60Hz)

Note 1: Measurement condition:

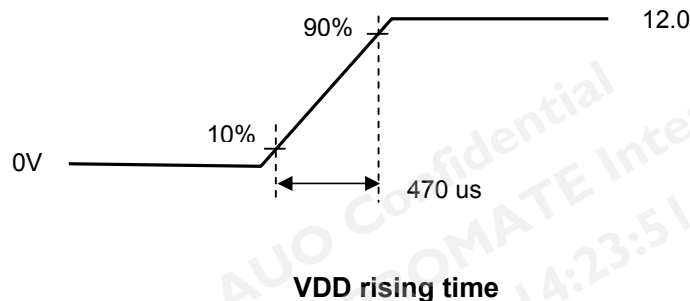
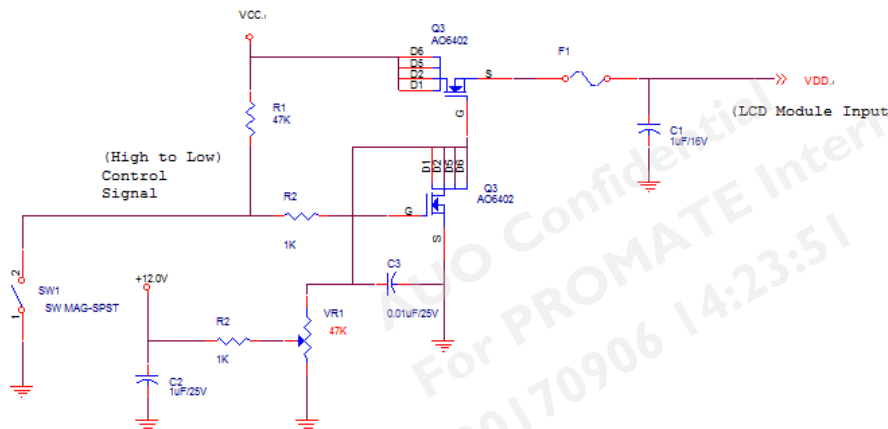



5.2 Backlight Unit

5.2.1 LED Backlight Unit: Driver Connector

Connector Name / Designation	Lamp Connector
Manufacturer	JST
Connector Model Number	S14B-PH-SM6-K-TB(HF)
Mating Model Number	PHR-14

Pin #	Symbol	Pin Description
1	VBL	+24V
2	VBL	+24V
3	VBL	+24V
4	VBL	+24V
5	VBL	+24V
6	GND	GND
7	GND	GND
8	GND	GND
9	GND	GND
10	GND	GND
11	DC_Dimming	DC Dimming (Hi: 3VDC, Lo:0VDC)
12	BLON	BL ON/OFF (ON:3.3V, OFF:0V)
13	NC	N/A
14	E_PWM	External PWM Control (Hi Level: 3V, Lo Level: 0V)

Note 1: Use the PWM mode. The pin.11 must be NC.

Note 2: Use the DC mode. The pin.14 must be NC.

5.2.2 Parameter guideline for LED

Following characteristics are measured under a stable condition using an inverter at 25°C (Room Temperature):

LED characteristics

Symbol	Parameter	Min	Typ	Max	Units	Condition
PLED	Backlight Power Consumption	-	82.56	93.57	[Watt]	LED only
LTLED	LED Life-Time	30,000	--	--	Hour	LED only

Note 1: Calculator value for reference $P_{LED} = V_F$ (Normal Distribution) * I_F (Normal Distribution) / Efficiency

Note 2: The LED life-time define as the estimated time to 50% degradation of initial luminous.

Backlight input signal characteristics

Symbol	Parameter	Min.	Typ.	Max.	Unit	Remark
VDD	Input Voltage	23.5	24.0	24.5	[Volt]	
I _{VDD}	Input Current		4.05	4.59	[A]	100% PWM Duty
P _{VDD}	Power Consumption		97.13	110.08	[Watt]	100% PWM Duty
Backlight on/off	On control Voltage	2	3.3	5	[Volt]	
	Off control Voltage			0.8	[Volt]	
SEL	SEL High level	2	3.3	5	[Volt]	
	SEL Low level			0.8	[Volt]	
DC	DC Dimming	0		3	[Volt]	
F _{PWM}	Dimming Frequency	0.2		15	[kHz]	
	Swing Voltage		3		V	
	Dimming Duty Cycle	10	-	100	%	
I _{F (one channel)}	LED Forward Current		107.5		mA	Ta = 25°C

Note 1: Ta means ambient temperature of TFT-LCD module.

Note 2: VDD, I_{VDD}, P_{VDD}, I_{rush} LED are defined for LED B/L.(100% duty of PWM dimming)

6. Signal Characteristic

6.1 Pixel Format Image

Following figure shows the relationship between input signal and LCD pixel format.

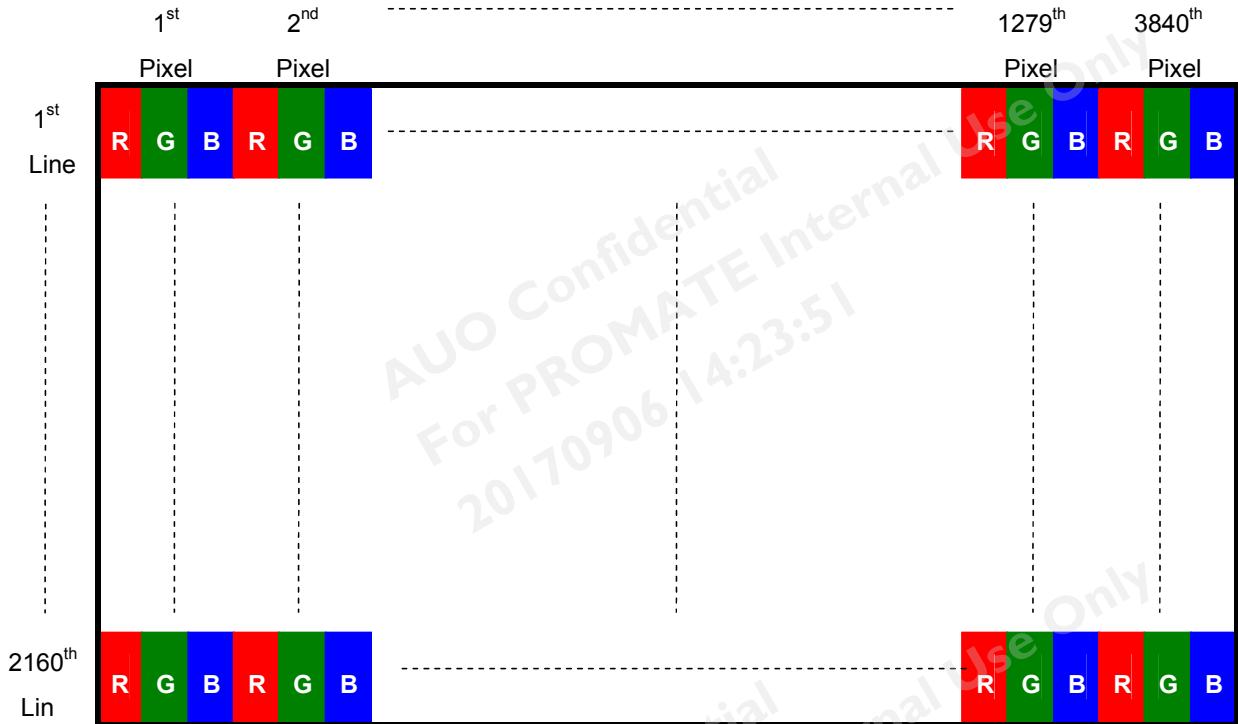

6.2 Scanning Direction

The following figures show the image seen from the front view. The arrow indicates the direction of scan.

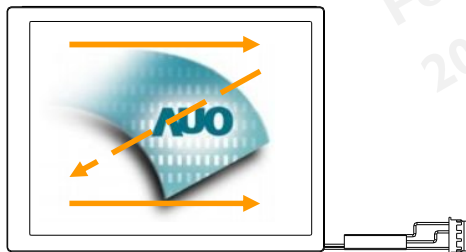



6.3 Signal Description

The module uses a LVDS receiver embedded in AUO's ASIC. LVDS is a differential signal technology for LCD interface and a high-speed data transfer device.

6.3.1 TFT LCD Module: LVDS Connector

Connector Name / Designation	Signal Connector
Manufacturer	JAE
Connector Model Number	FI-RE51S-HF
Adaptable Plug	FI-RE51HL

Pin No.	Function	Pin No.	Function
1	Power input (+12V)	26	Lock detect output, Open drain.
2	Power input (+12V)	27	Ground
3	Power input (+12V)	28	1st Pixel Negative VbyOne differential data input in area A. Lan 0
4	Power input (+12V)	29	1st Pixel Positive VbyOne differential data input in area A. Lan 0
5	Power input (+12V)	30	Ground
6	Power input (+12V)	31	2nd Pixel Negative VbyOne differential data input in area A. Lan 1
7	Power input (+12V)	32	2nd Pixel Positive VbyOne differential data input in area A. Lan 1
8	Power input (+12V)	33	Ground
9	No Connection	34	3rd Pixel Negative VbyOne differential data input in area A. Lan 2
10	Ground	35	3rd Pixel Positive VbyOne differential data input in area A. Lan 2
11	Ground	36	Ground
12	Ground	37	4th Pixel Negative VbyOne differential data input in area A. Lan 3
13	Ground	38	4th Pixel Positive VbyOne differential data input in area A. Lan 3
14	Ground	39	Ground
15	No Connection	40	5th Pixel Negative VbyOne differential data input in area A. Lan 4
16	No Connection	41	5th Pixel Positive VbyOne differential data input in area A. Lan 4
17	No Connection	42	Ground
18	For internal use, no connection	43	6th Pixel Negative VbyOne differential data input in area A. Lan 5
19	For internal use, no connection	44	6th Pixel Positive VbyOne differential data input in area A. Lan 5
20	No Connection	45	Ground
21	No Connection	46	7th Pixel Negative VbyOne differential data input in area A. Lan 6
22	No Connection	47	7th Pixel Positive VbyOne differential data input in area A. Lan 6
23	No Connection	48	Ground
24	No Connection	49	8th Pixel Negative VbyOne differential data input in area A. Lan 7
25	Hot plug detect output, Open drain.	50	8th Pixel Positive VbyOne differential data input in area A. Lan 7
		51	Ground



Product Specification

G320ZAN01.0

AU OPTRONICS CORPORATION

Note1: Pin1 start position

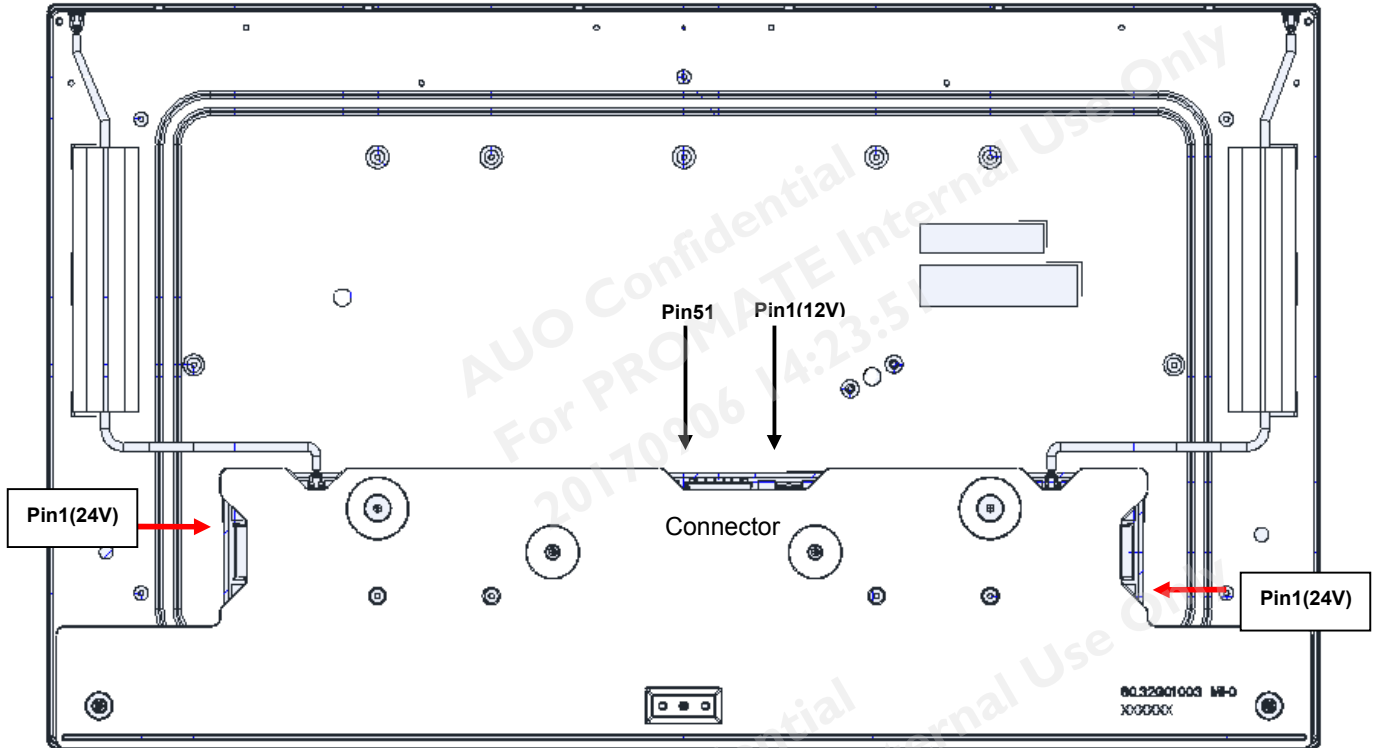



6.4 The Input Data Format

6.4.1 Color data input reference

The brightness of each primary color is based on the 10bit gray scale data input for the color; the higher the binary input, the brighter the color. The table below provides a reference for color versus data input.

Color	Input color data																													
	RED										GREEN										BLUE									
	MSB					LSB					MSB					LSB					MSB					LSB				
	R9	R8	R7	R6	R5	R4	R3	R2	R1	R0	G9	G8	G7	G6	G5	G4	G3	G2	G1	G0	B9	B8	B7	B6	B5	B4	B3	B2	B1	B0
Basic Color	Black	0	0	0	0	0	0	0	0	0	0	0	0	0	0	0	0	0	0	0	0	0	0	0	0	0	0	0	0	0
	Red(0123)	1	1	1	1	1	1	1	1	1	0	0	0	0	0	0	0	0	0	0	0	0	0	0	0	0	0	0	0	0
	Green(1023)	0	0	0	0	0	0	0	0	0	1	1	1	1	1	1	1	1	1	1	0	0	0	0	0	0	0	0	0	0
	Blue(1023)	0	0	0	0	0	0	0	0	0	0	0	0	0	0	0	0	0	0	0	1	1	1	1	1	1	1	1	1	1
	Cyan	0	0	0	0	0	0	0	0	0	1	1	1	1	1	1	1	1	1	1	1	1	1	1	1	1	1	1	1	1
	Magenta	1	1	1	1	1	1	1	1	1	0	0	0	0	0	0	0	0	0	0	1	1	1	1	1	1	1	1	1	1
	Yellow	1	1	1	1	1	1	1	1	1	1	1	1	1	1	1	1	1	1	1	0	0	0	0	0	0	0	0	0	0
	White	1	1	1	1	1	1	1	1	1	1	1	1	1	1	1	1	1	1	1	1	1	1	1	1	1	1	1	1	1
R	RED(000)	0	0	0	0	0	0	0	0	0	0	0	0	0	0	0	0	0	0	0	0	0	0	0	0	0	0	0	0	0
	RED(001)	0	0	0	0	0	0	0	0	1	0	0	0	0	0	0	0	0	0	0	0	0	0	0	0	0	0	0	0	0
																													
	RED(1022)	1	1	1	1	1	1	1	1	0	0	0	0	0	0	0	0	0	0	0	0	0	0	0	0	0	0	0	0	0
RED(1023)	1	1	1	1	1	1	1	1	1	0	0	0	0	0	0	0	0	0	0	0	0	0	0	0	0	0	0	0	0	
G	Green(000)	0	0	0	0	0	0	0	0	0	0	0	0	0	0	0	0	0	0	0	0	0	0	0	0	0	0	0	0	0
	Green(001)	0	0	0	0	0	0	0	0	0	0	0	0	0	0	0	0	0	0	1	0	0	0	0	0	0	0	0	0	0
																													
	Green(1022)	0	0	0	0	0	0	0	0	0	1	1	1	1	1	1	1	1	1	0	0	0	0	0	0	0	0	0	0	0
Green(1023)	0	0	0	0	0	0	0	0	0	1	1	1	1	1	1	1	1	1	1	0	0	0	0	0	0	0	0	0	0	
B	Blue(000)	0	0	0	0	0	0	0	0	0	0	0	0	0	0	0	0	0	0	0	0	0	0	0	0	0	0	0	0	0
	Blue(001)	0	0	0	0	0	0	0	0	0	0	0	0	0	0	0	0	0	0	0	0	0	0	0	0	0	0	0	0	1
																													
	Blue(1022)	0	0	0	0	0	0	0	0	0	0	0	0	0	0	0	0	0	0	0	1	1	1	1	1	1	1	1	1	0
Blue(1023)	0	0	0	0	0	0	0	0	0	0	0	0	0	0	0	0	0	0	0	1	1	1	1	1	1	1	1	1	1	



6.4.2 The Input Data Format

Mode	Packer input & Unpacker output	30bpp RGB / YCbCr444 (10bit)	
4byte mode	Byte0	D[0]	R/Cr[2]
		D[1]	R/Cr[3]
		D[2]	R/Cr[4]
		D[3]	R/Cr[5]
		D[4]	R/Cr[6]
		D[5]	R/Cr[7]
		D[6]	R/Cr[8]
	Byte1	D[7]	R/Cr[9]
		D[8]	G/Y[2]
		D[9]	G/Y[3]
		D[10]	G/Y[4]
		D[11]	G/Y[5]
		D[12]	G/Y[6]
	Byte2	D[13]	G/Y[7]
		D[14]	G/Y[8]
		D[15]	G/Y[9]
		D[16]	B/Cb[2]
		D[17]	B/Cb[3]
		D[18]	B/Cb[4]
	Byte3	D[19]	B/Cb[5]
		D[20]	B/Cb[6]
D[21]		B/Cb[7]	
D[22]		B/Cb[8]	
D[23]		B/Cb[9]	
D[24]		--	
D[25]		--	
D[26]		B/Cb[0]	
D[27]		B/Cb[1]	
D[28]	G/Y[0]		
D[29]	G/Y[1]		
D[30]	R/Cr[0]		
D[31]	R/Cr[1]		

6.4.3 Timing Diagram

(Lane1~8 V By One data:1, 2, 3, 4, 1921, 1922, 1923, 1924)

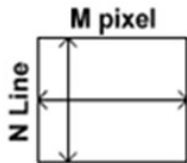
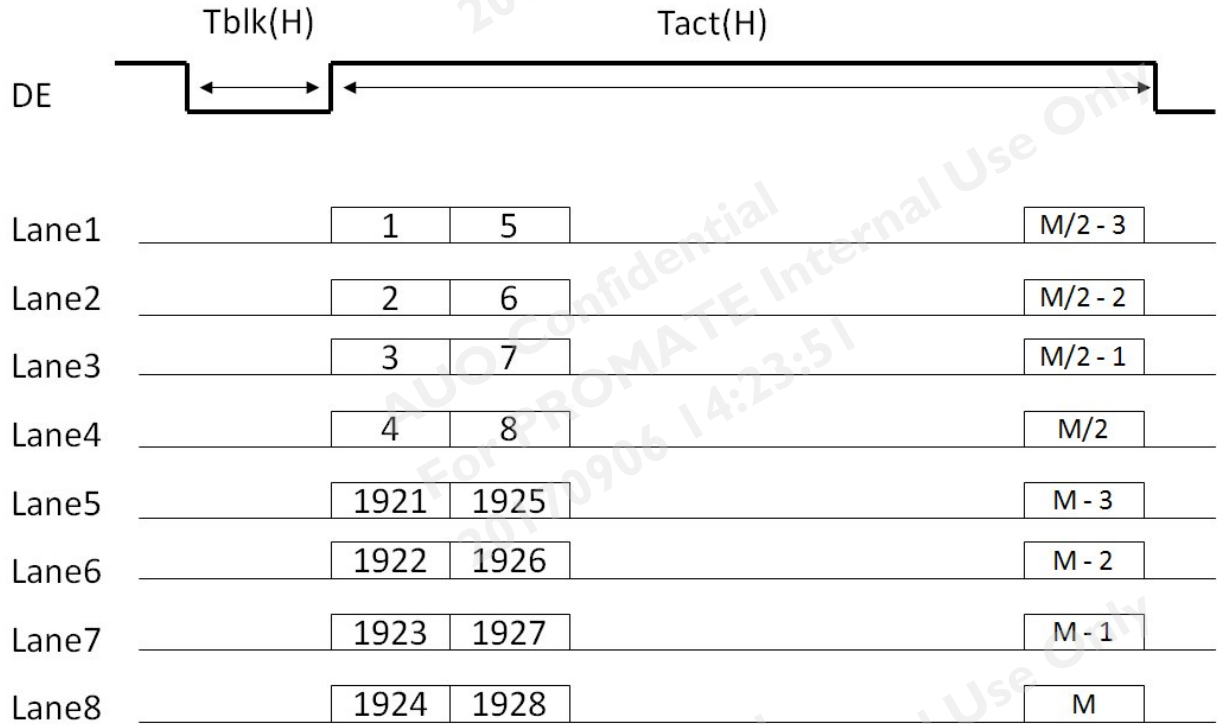



6.5 Interface Timing

6.5.1 Timing Characteristics

Signal	Item	Symbol	Min	Typ	Max	Unit
Vertical Section	Period	T_v	2200	2250	2660	Th
	Active	$T_{disp(v)}$	-	2160	-	Th
	Blanking	$T_{bp(v)}+T_{fp(v)}+PW_{vs}$	40	90	500	Th
Horizontal Section	Period	T_h	530	550	600	Tclk
	Active	$T_{disp(h)}$	-	480	-	Tclk
	Blanking	$T_{bp(h)}+T_{fp(h)}+PW_{hs}$	50	70	120	Tclk
Clock	Period	Tclk	15.15	13	12.98	ns
	Frequency	Freq.	66	74.25	77	MHz
Frame Rate	Frequency	$1/T_v$	45	60	63	Hz

Note : DE mode only

6.5.2 V-By-One SPEC

Item	Symbol	Min.	Typ.	Max	Unit	Note	
V-by-one Interface	VRXINP/N input each bit Period	TRRIP	310	--	379	ps	1
	CDR training pattern time	TLOCK	--	500	--	us	1
	Latency from LOCKN 'HIGH' to clock training pattern	L1	0	--	--	us	1
	Latency from LOCKN 'LOW' to normal 8b10b data	L2	--	--	70	us	1
	CML Differential Input High Threshold	V_{RTH}	+50			mV _{DC}	
	CML Differential Input Low Threshold	V_{RTL}			-50	mV _{DC}	
	CML Common mode Bias Voltage	V_{RCT}	0.8	0.9	1.0	mV _{DC}	
	Intra-pair skew	T_{INTRA}	--	--	0.3	UI	2
	Inter-pair skew	T_{INTER}	--	--	5	UI	3

1. V-By-One Signal diagram

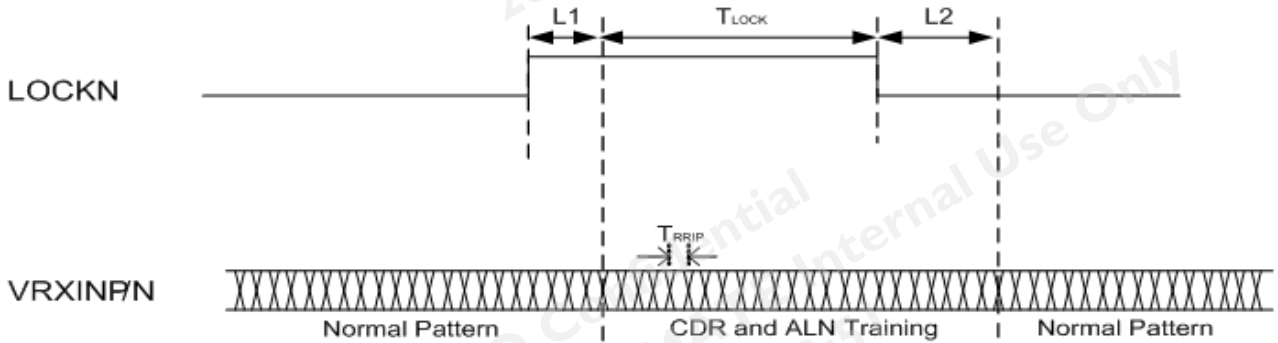

2. V-By-One intra-pair Skew

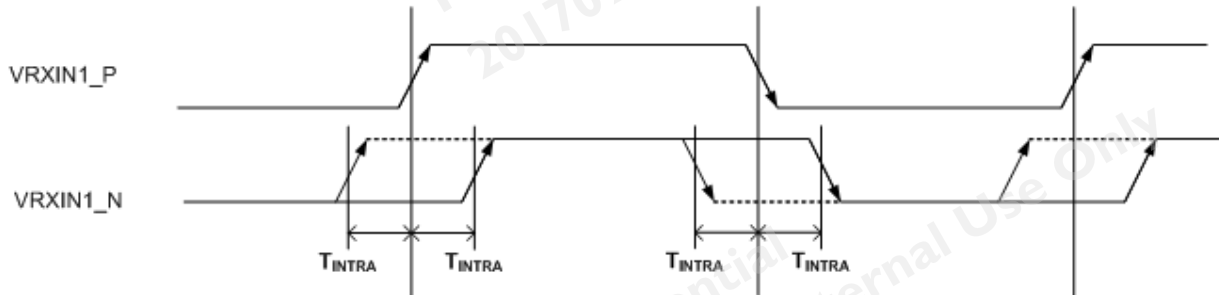

3. V-By-One intra-pair Skew

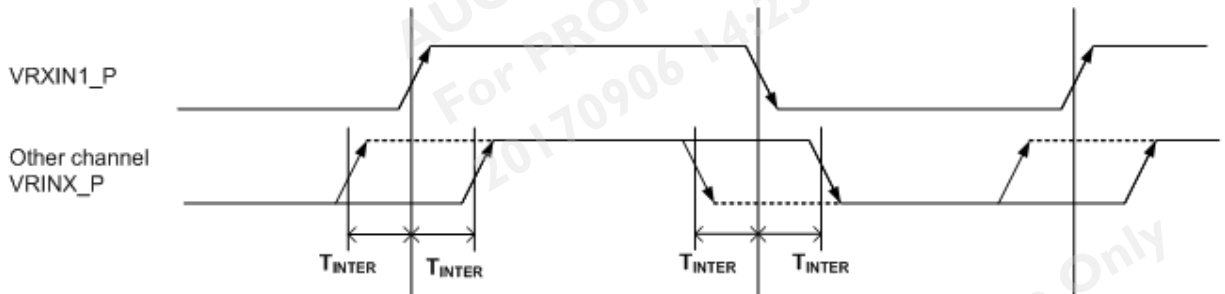

6.5.3 V-By-One Eye diagram at receiver

Item	Symbol	Min.	Typ.	Max	Unit	Note
V-by-one Interface	A_X	--	0.25	--	UI	1.
	A_Y	--	0	--	mV	
	B_X	--	0.3	--	UI	
	B_Y	--	50	--	mV	
	C_X	--	0.7	--	UI	
	C_Y	--	50	--	mV	
	D_X	--	0.75	--	UI	
	D_Y	--	0	--	mV	
	E_X	--	0.7	--	UI	
	E_Y	--	-50	--	mV	
	F_X	--	0.3	--	UI	
	F_Y	--	-50	--	mV	

Note1. Eye Mask

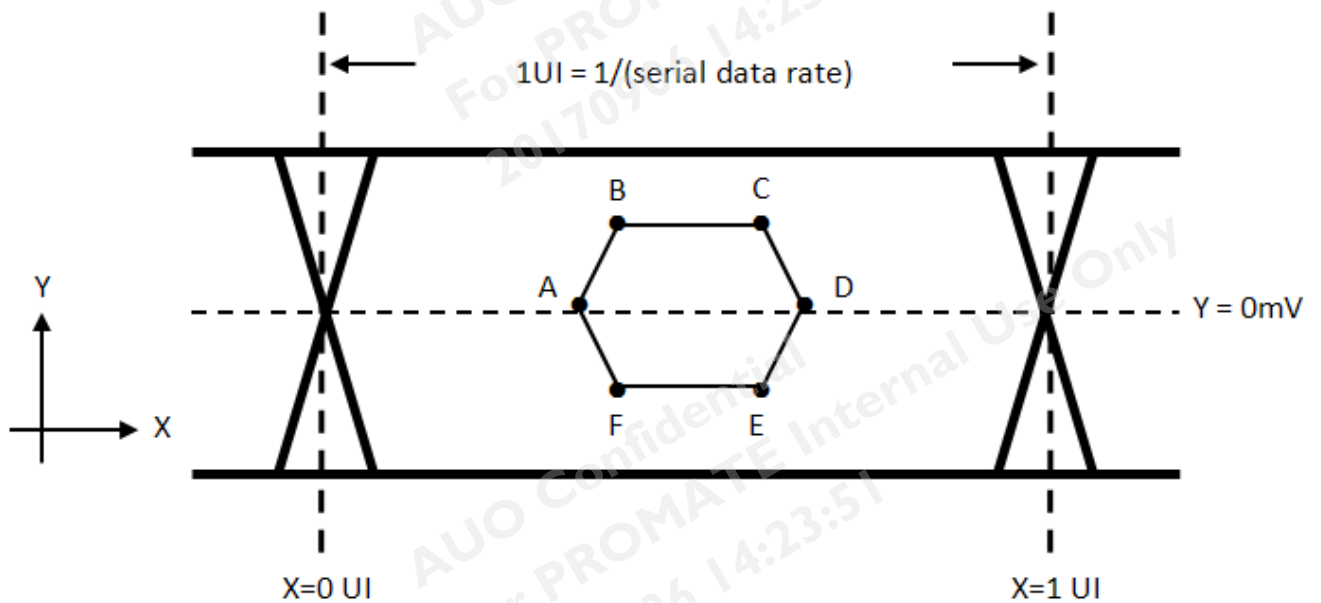

6.6 Power ON/OFF Sequence

VDD power and lamp on/off sequence is as below. Interface signals are also shown in the chart. Signals from any system shall be Hi-Z state or low level when VDD is off.

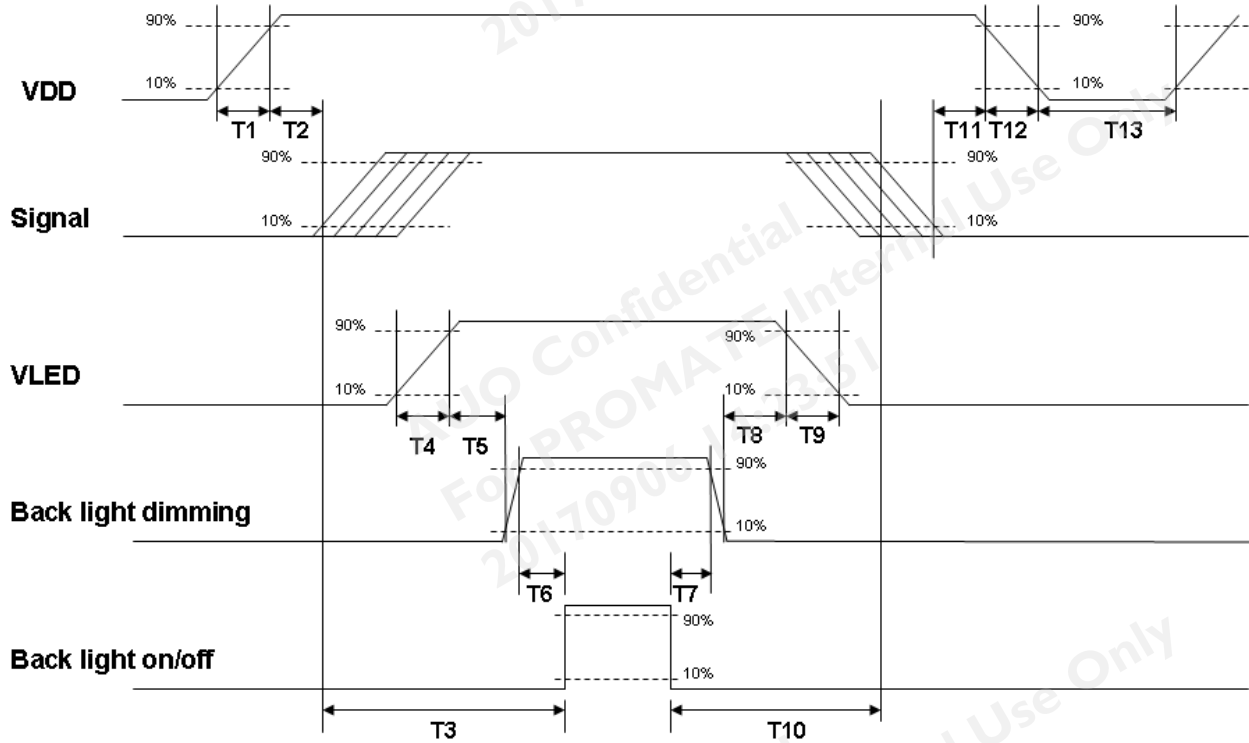

Power sequence timing

Parameter	Value			Units
	Min.	Typ.	Max.	
T1	0.5	-	10	[ms]
T2	30	40	50	[ms]
T3	200	-	--	[ms]
T4	0.5	-	10	[ms]
T5	10	-	-	[ms]
T6	10	-	-	[ms]
T7	0	-	-	[ms]
T8	10	-	-	[ms]
T9	-	-	10	[ms]
T10	110	-	-	[ms]
T11	0	16	50	[ms]
T12	0	-	10	[ms]
T13	1000	-	-	[ms]

The above on/off sequence should be applied to avoid abnormal function in the display. Please make sure to turn off the power when you plug the cable into the input connector or pull the cable out of the connector.



7. Reliability Test Criteria

Items	Required Condition	Note
Temperature Humidity Bias (Ts)	50 °C /80%,300Hr	
High Temperature Operation (Ts)	50 °C, 300Hr (center point of panel surface)	
Low Temperature Operation (Ts)	0 °C, 300Hr	
Hot Storage	60 °C, 300 hours	
Cold Storage	-20 °C, 300 hours	
Thermal Shock Test (Ts)	-20 °C /30 min ,60 °C /30 min ,100cycles, 40 °C minimum ramp rate	
Shock Test (Non-Operating)	50G,20ms,Half-sine wave,(+X,+Y,+Z)	
Vibration Test (Non-Operating)	1.0G, 10~300Hz, Random wave 10mins/axis, 3 direction (X, Y, Z)	
ESD	Contact : ± 8KV/ operation, Class B Air : ± 15KV / operation, Class B	Note 1

Note1: According to EN61000-4-2 , ESD class B: Some performance degradation allowed. No data lost
 . Self-recoverable. No hardware failures.

Note2:

- Ts is defined as panel surface temperature
- Water condensation is not allowed for each test items.
- Each test is done by new TFT-LCD module. Don't use the same TFT-LCD module repeatedly for reliability test.
- The reliability test is performed only to examine the TFT-LCD module capability.
- To inspect TFT-LCD module after reliability test, please store it at room temperature and room humidity for 24 hours at least in advance.
- No function failure occurs.



Product Specification

AU OPTRONICS CORPORATION

G320ZAN01.0

8. Mechanical Characteristics

8.1 LCM Outline Dimension

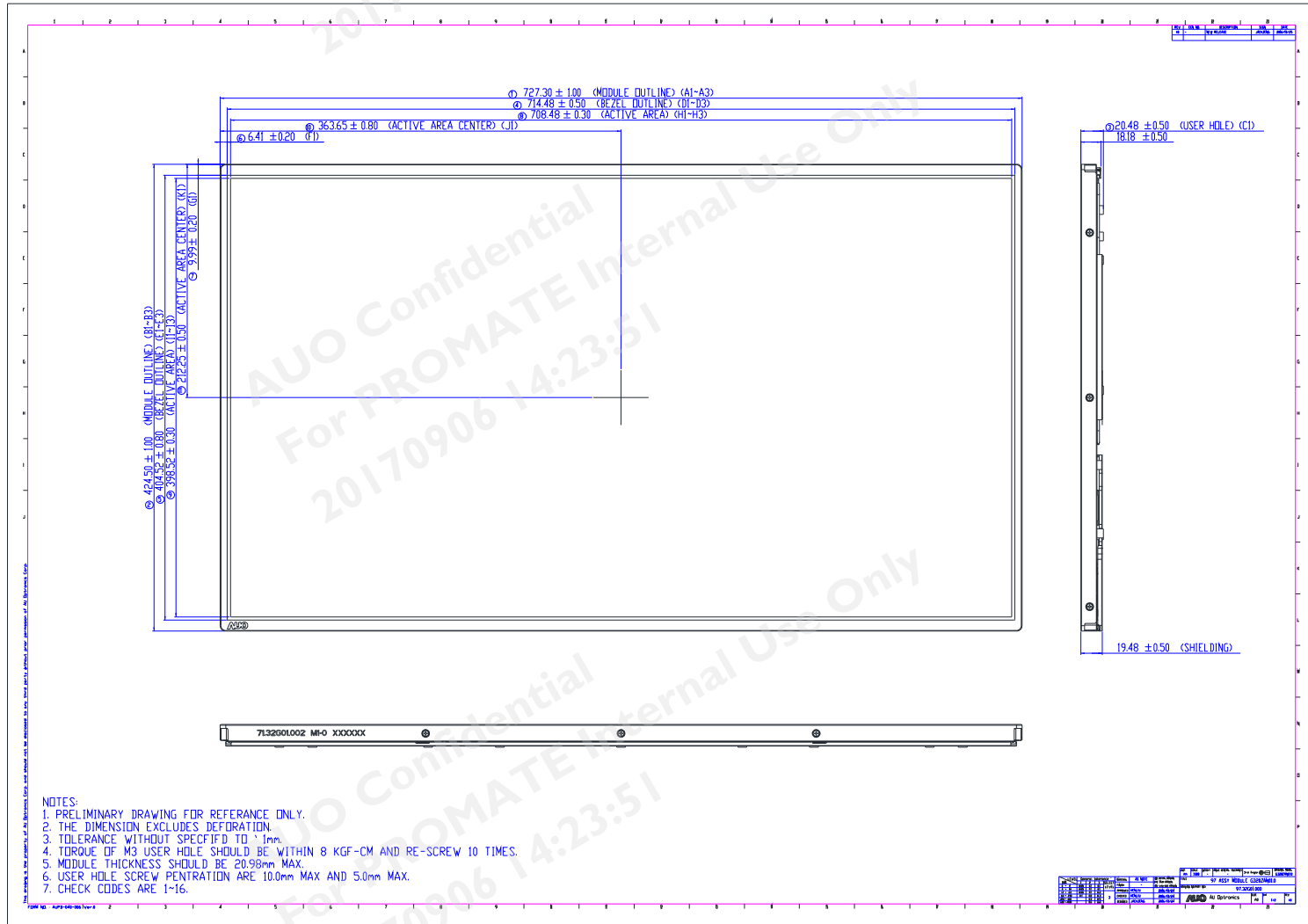



Product Specification

AU OPTRONICS CORPORATION

G320ZAN01.0

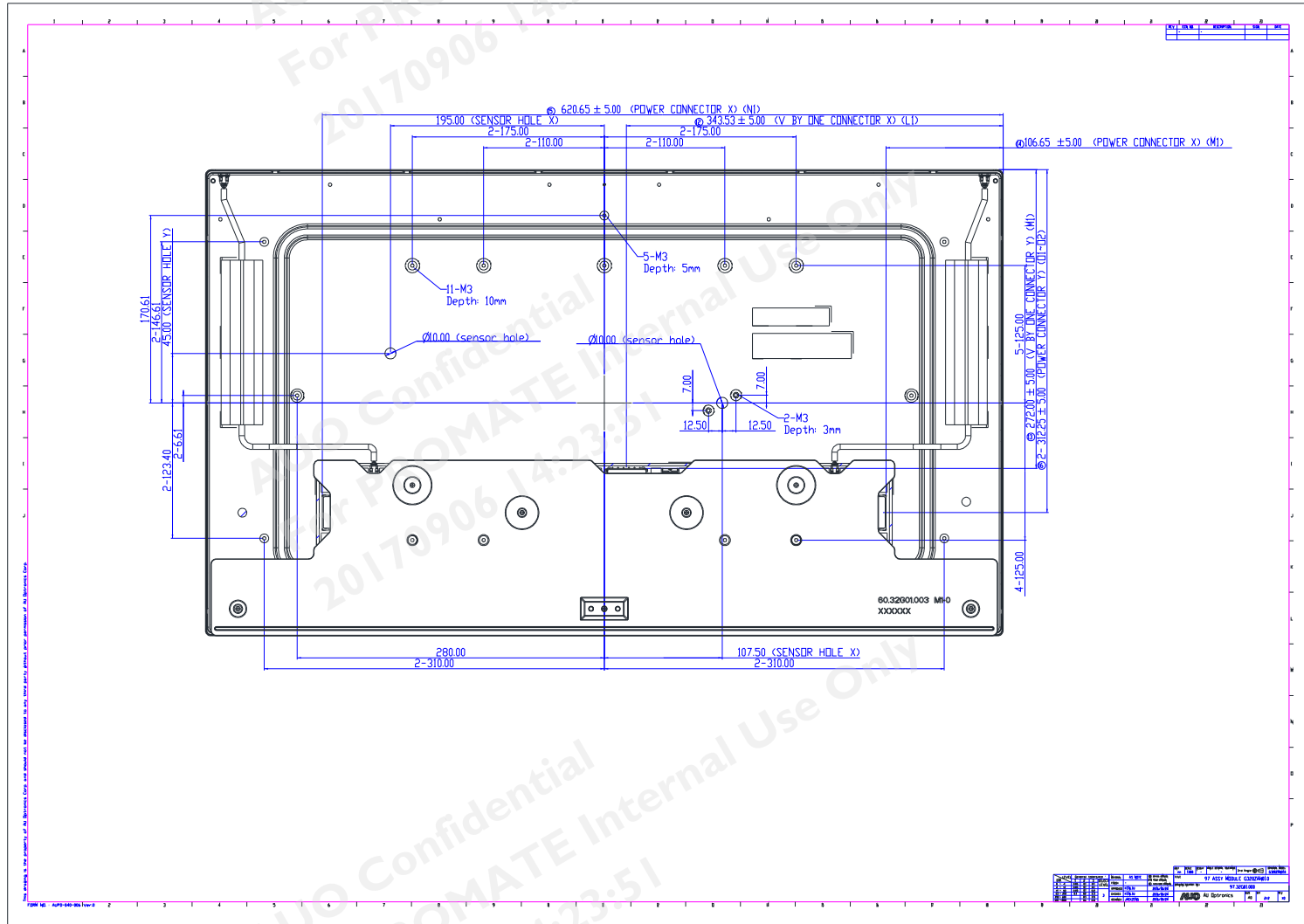

9. Label and Packaging

9.1 Shipping Label (on the rear side of TFT-LCD display)

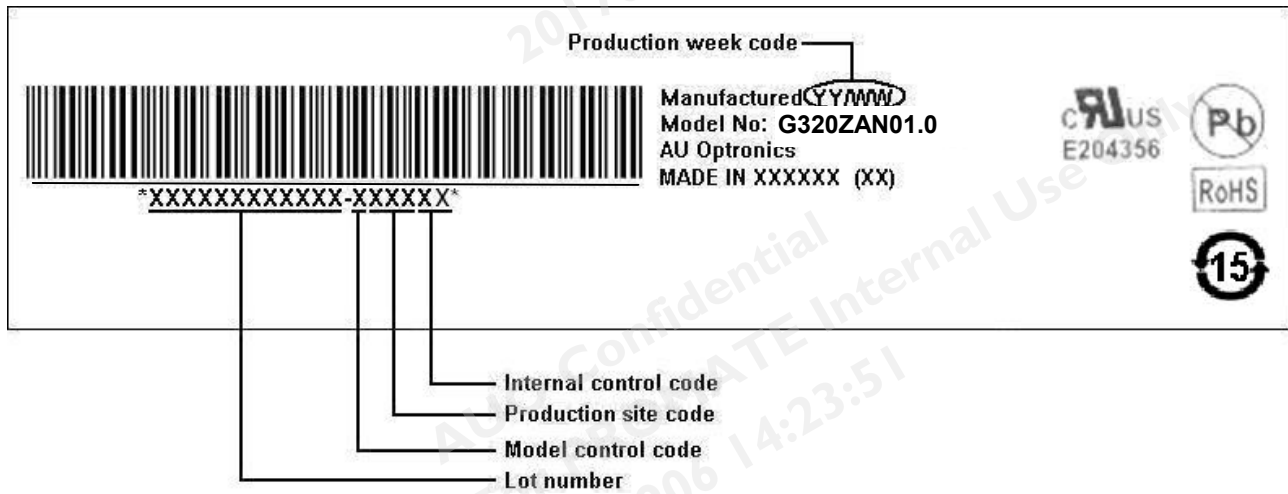

9.2 Carton Package

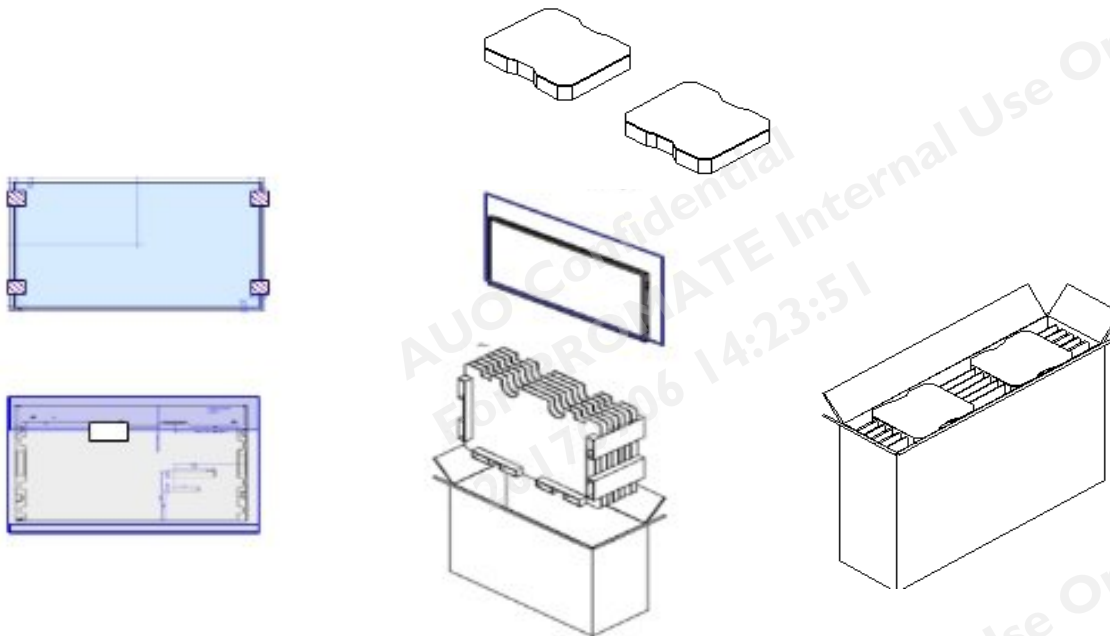

Max capacity : 4 PCS TFT-LCD module per carton

Max weight: 27kg per carton

Outside dimension of carton: 820mm(L)* 220mm(W)* 535mm(H)

Pallet size : 1150mm * 840mm * 133mm

Box stacked

Module by air_Max : (1*5) * 2 layers , one pallet put 10boxes , total 40pcs module

Module by sea_Max : (1 * 5) * 2 layers + (1 * 5) * 1 layers , two pallet put 15boxes , total 60pcs module

Module by sea_HQ_Max : (1 * 5) * 2 layers+(1 * 5) * 2 layers, two pallet put 20 boxes, total 80pcs module



10 Safety

10.1 Sharp Edge Requirements

There will be no sharp edges or comers on the display assembly that could cause injury.

10.2 Materials

10.2.1 Toxicity

There will be no carcinogenic materials used anywhere in the display module. If toxic materials are used, they will be reviewed and approved by the responsible AUO toxicologist.

10.2.2 Flammability

All components including electrical components that do not meet the flammability grade UL94-V1 in the module will complete the flammability rating exception approval process.

The printed circuit board will be made from material rated 94-V1 or better. The actual UL flammability rating will be printed on the printed circuit board.

10.3 Capacitors

If any polarized capacitors are used in the display assembly, provisions will be made to keep them from being inserted backwards.

10.4 National Test Lab Requirement

The display module will satisfy all requirements for compliance to:

UL 60950-1 second edition

U.S.A. Information Technology Equipment