

Issued date 29 Dec. 1994

Spec. No. MG321EV5B000-001

LIQUID CRYSTAL DISPLAY MODULE

G 3 2 1 E V 5 B 0 0 0

PRODUCT SPECIFICATION

APPROVAL

--

Seiko Instruments Inc. Display Division

Akita Seimitsu Denshi Kogyo Co., Ltd

Quality Assurance Section	<i>J. Motomura</i>
Technology Department	<i>A. Fujita</i>

Seiko Instruments Inc.

CONTENTS

1.	SCOPE	1
2.	PRODUCT SPECIFICATIONS	1
2.1	General	1
2.2	Mechanical Characteristics	1
2.3	Absolute Maximum Ratings	2
2.4	Electrical Characteristics	2
2.5	Optical Characteristics	3
2.6	Dimensions	7
2.7	Circuit Block Diagram	8
2.8	FL Backlight Characteristics	9
3.	RELIABILITY	11
4.	OPERATING INSTRUCTIONS	12
5.	NOTES	16
6.	OPERATION PRECAUTIONS	17

[REVISION RECORD]

DATE	ITEM	CONTENT	(Rev)	REASON
1994.12.29		Issued	(001)	

1. SCOPE

This specification covers the engineering requirements for the G321EV5B000 liquid crystal module delivered by Seiko Instruments Inc.

2. PRODUCT SPECIFICATIONS

2.1 General

- 320 × 240 dot matrix LCD
- Super New TN (SNTN) LCD panel
Blue mode
- 1/240 duty, 1/13.1 bias drive
- 4-bit parallel data input
- Negative type
(Display data "H" : Display ON : White , Display data "L" : Display OFF : Blue)
- Transmissive type
- 6 o'clock viewing angle
- Dual power supply : V_{DD}, V_{LCD}
- Built-in FL backlight (Lamp unit is exchangeable)

2.2 Mechanical Characteristics

Item	Characteristic
Dot configuration	320 × 240 dots
Dot dimensions [mm]	0.27 × 0.27
Dot spacing [mm]	0.03
Module dimensions (Horizontal x Vertical x Thickness, [mm])	150.0 × 96.0 × 14.0 max.
Viewing area (Horizontal x Vertical, [mm])	103.0 × 80.0
Active display area (Horizontal x Vertical, [mm])	95.97 × 71.97
Weight [g]	195 typ.

2.3 Absolute Maximum Ratings

$V_{SS} = 0V$

Item	Symbol	Conditions	Standard		Unit
			Min.	Max.	
Power supply voltage	V_{DD}	$T_a = 25^\circ C$ $50 \pm 10\% R.H$	-0.3	6.0	V
	V_{LC}		$V_{DD} - 30.0$	V_{DD}	V
	V_O^*		$V_{DD} - 30.0$	V_{DD}	V
Input voltage	V_{in}		-0.3	$V_{DD} + 0.3$	V
Operating temperature	T_{opr}	$\leq 65\% RH$	0	50	$^\circ C$
Storage temperature	T_{stg}		-20	60	$^\circ C$
Storage humidity		≤ 48 hrs	20	85	%RH
		≤ 1000 hrs	20	65	%RH

* $V_O \geq V_{LC}$

2.4 Electrical Characteristics (Without FL Backlight)

$V_{SS} = 0V$, $T_a = 0 \sim 50^\circ C$

Item	Symbol	Conditions	Standard			Unit
			Min.	Typ.	Max.	
Power supply voltage	V_{DD}	$V_{DD} = 5.0V$	4.75	5.00	5.25	V
	V_{LC}		-24.5	-24.0	-23.5	V
	V_O^{**}		-23.0	-	-5.0	V
Input voltage	High	$V_{DD} = 5.0V \pm 5\%$	$0.8V_{DD}$	-	V_{DD}	V
	Low		V_{IL}	0	-	$0.2V_{DD}$
Current consumption*	I_{DD}	$T_a = 25^\circ C$	-	6.4	15.0	mA
	I_{LC}		-	5.7	15.0	mA

* $V_{DD} = 5.0V$, $V_O = -16.2V$

Frequency of data shift clock : 3.0MHz , Frame frequency: 70.0Hz

Display pattern : Checker pattern

** $V_O \geq V_{LC}$

2.5 Optical Characteristics

2.5.1 Optical characteristics

1/240 duty, 1/13.1 bias, $V_{opr} = V_{DD} - V_O$

Item	Symbol	Conditions	Temp.	Min.	Typ.	Max.	Unit
Contrast	C	$\theta = 0^\circ$ $\phi = 0^\circ$ $V_{opr} = 21.2\text{ V}$	25°C	2.0	3.0	-	
Viewing angle	θ_1	$C \geq 2.0$ $\phi = 0^\circ$ $V_{opr} = 21.2\text{ V}$	25°C	-	-	-15	deg.
	θ_2			20	-	-	
	$\theta_2 - \theta_1$			35	-	-	
Response time	t_{on}	$\theta = 0^\circ$ $\phi = 0^\circ$ $V_{opr} = 21.2\text{ V}$	25°C	-	170	260	ms
	t_{off}			-	190	290	
	t_{on}	$\theta = 0^\circ$ $\phi = 0^\circ$ $V_{opr} = 22.8\text{ V}$	0°C	-	1100	1700	ms
	t_{off}			-	500	750	

(FL backlight : ON)

Measuring equipment: Canon illuminometer LC-35

* Optical characteristics measurement

Set the FL backlight behind the liquid crystal display panel, receive the transmitted light with a light-receiving element, convert the quantity of transmitted light to voltage, and measure the optical characteristics.

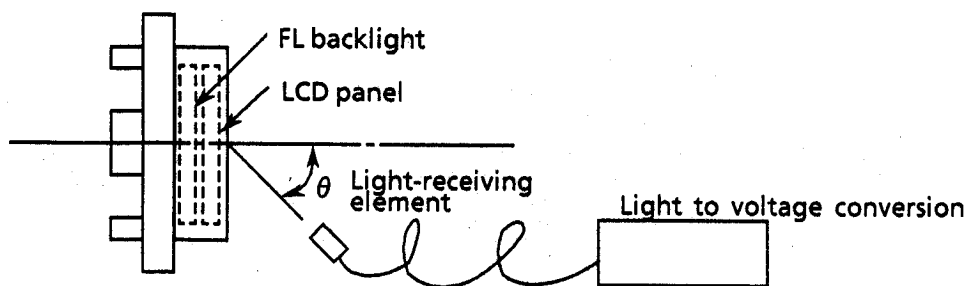

** Response time measurement

Use a transmissive panel to measure the response time.

2.5.2 Recommended operating voltage ($V_{opr} = V_{DD} - V_O$)

Temperature (°C)	0	25	50
V_{opr} (V)	22.8	21.2	19.7

2.5.3 Recommended frame frequency

Set the frame frequency to the following value to prevent screen flicker.

Frame frequency (FLM frequency) : 70Hz±5%

2.5.4 Definition of optical characteristics

*Definition of angles \varnothing and θ

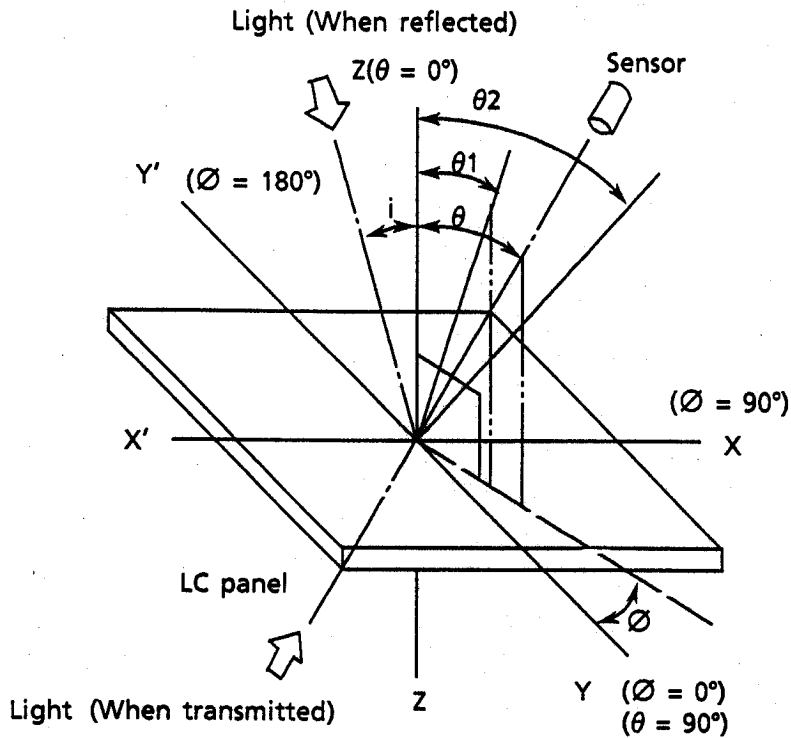

*Definition of contrast C

$$C = \frac{B_2}{B_1} = \frac{\text{Brightness of selected portion}}{\text{Brightness of unselected portion}}$$

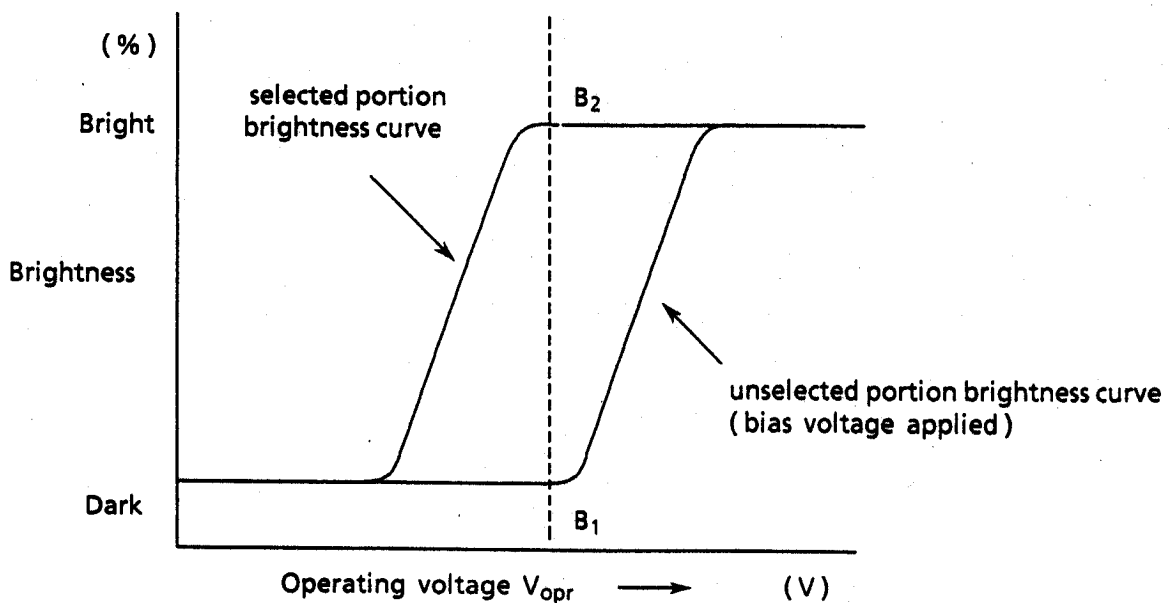

* Definition of viewing angles θ_1 and θ_2

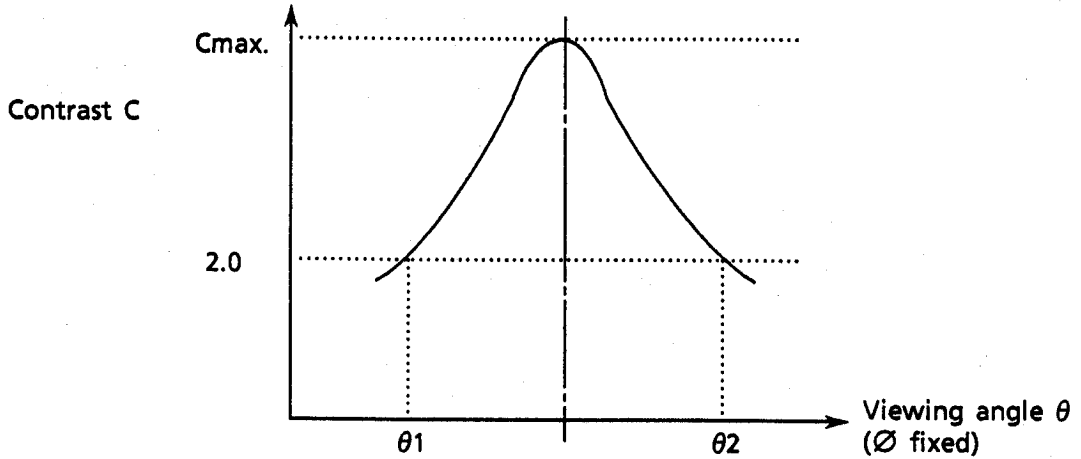

Note : Optimum vision with the naked eye and viewing angle θ at C_{max} above are not always the same.

* Definition of response time

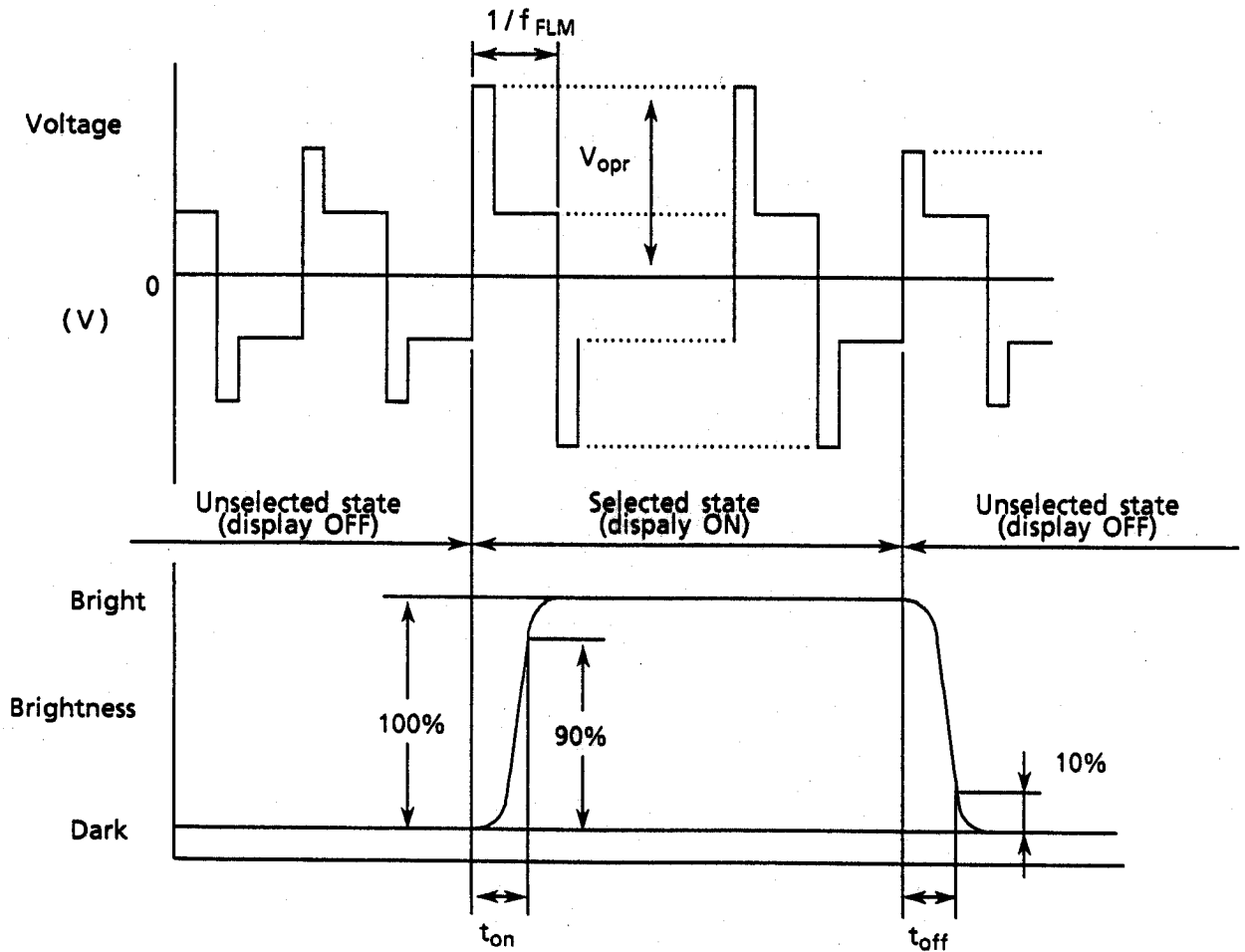

V_{opr} : Operating voltage (V)

t_{on} : Response time (rise) (ms)

f_{FLM} : Frame frequency (Hz)

t_{off} : Response time (fall) (ms)

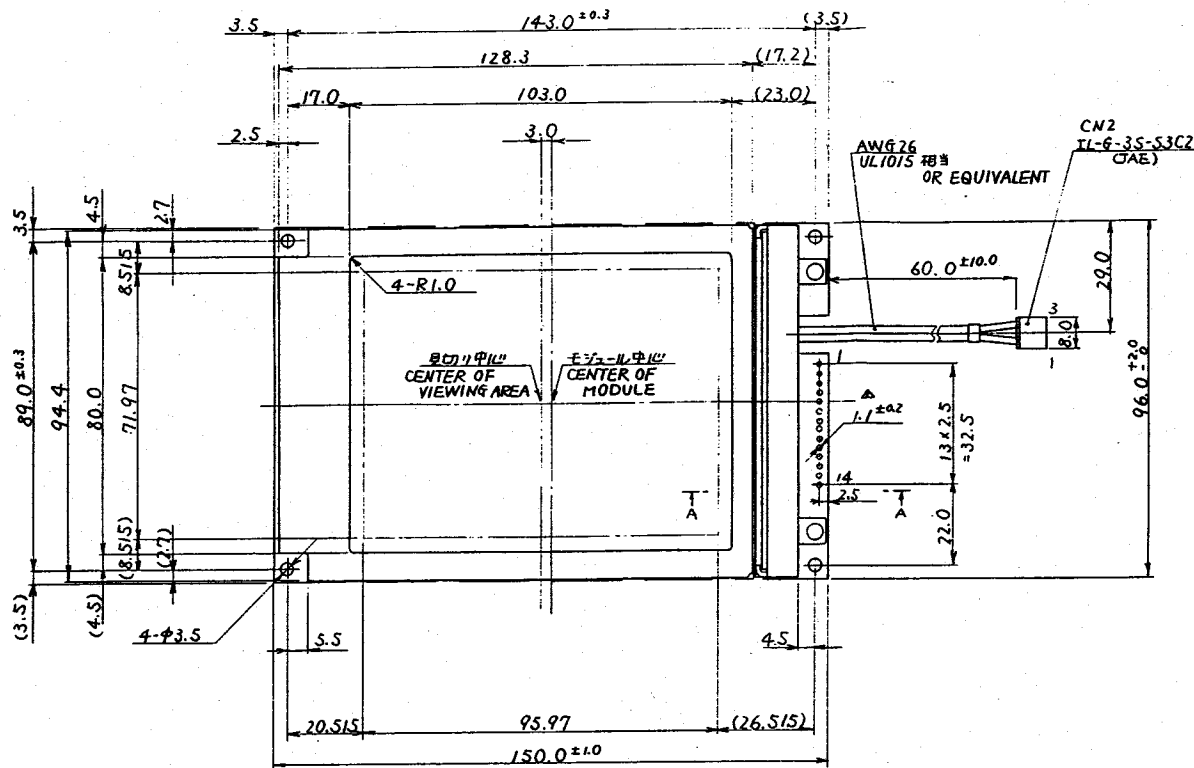

Dot Detail 20/1

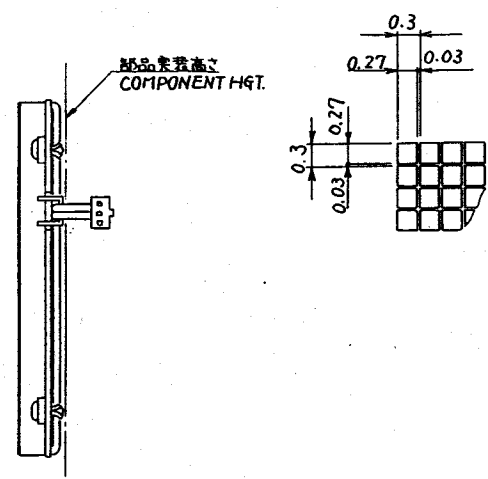

CN1

NO	SYMBOL
1	FLM
2	M
3	CL1
4	CL2
5	DISPOFF
6	D0
7	D1
8	D2
9	D3
10	VDD
11	VSS
12	VLC
13	Y0
14	FGND

CN2

NO	SYMBOL
1	VFLG
2	NC
3	VFLI

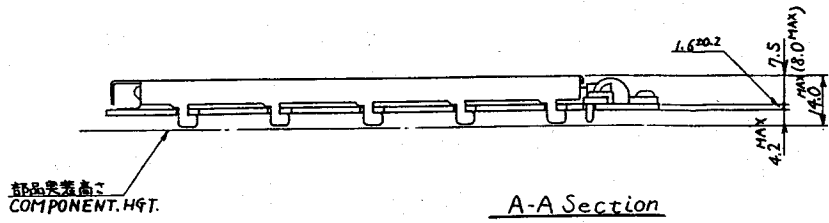

A-A Section

1994.12.15 試作品		DATE	1994.12.15
NUMBER	DATE	ITEM	CHECKED BY
CUSTOMER			
MODEL ORIGINAL NUMBER			
MATERIAL		QTY	
SCALE	UNIT	LEADER BY	DESIGNED BY
1/1	mm	Checked by	J. H. HALL
PART NUMBER		CHECKED BY	DRAWN BY
DRAWING NUMBER		DATE	
G321EV***00		1994.12.15	
TITLE		REV.	PAGE
組立図 ASSEMBLY DRAWING		A	1
Seiko Instruments Inc.			

2.7 Circuit Block diagram

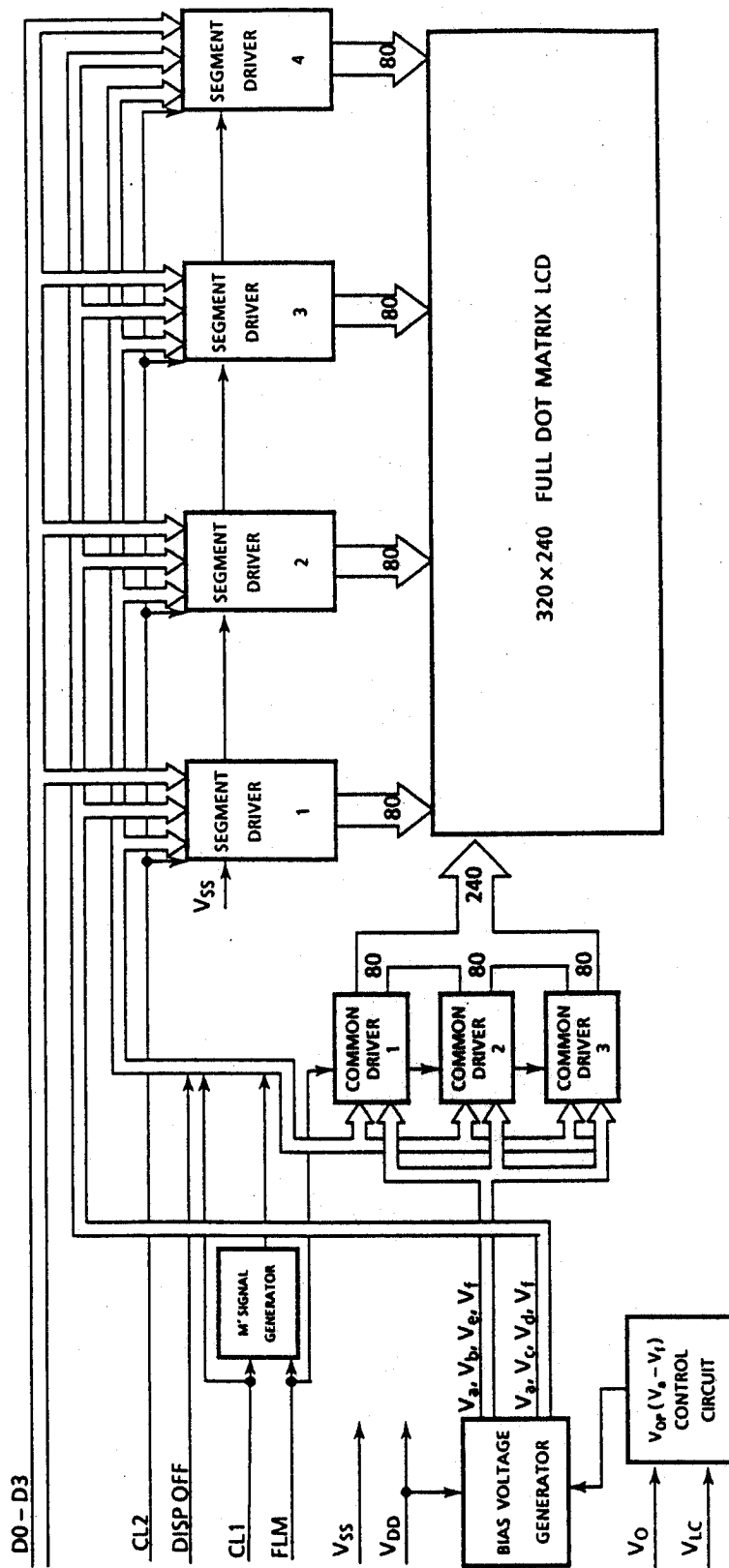

2.8 FL Backlight Characteristics

2.8.1 Absolute maximum ratings

Item	Symbol	Conditions	Standard			Unit
			Min.	Typ.	Max.	
Circuit voltage	V_S	$T_a = 25^\circ\text{C}$	-	-	2000	V rms
Lamp current	I_{FL}		-	-	10	mA rms
Frequency	f_{FL}		-	-	100	kHz

2.8.2 Electrical characteristics

Item	Symbol	Conditions	Standard			Unit
			Min.	Typ.	Max.	
Lamp voltage*1	V_{FL}	$T_a = 25^\circ\text{C}$	240	270	300	V rms
Starting voltage*2	V_S	$T_a = 0^\circ\text{C}$	-	-	650	V rms
Lamp current*1	I_{FL}	$T_a = 25^\circ\text{C}$	2.8	3.1	3.4	mA rms
Frequency*1	F_{FL}		41	47	53	KHz

*1 FL inverter: INVC303 (Hitachi, Ltd.)

FL inverter input voltage: $V_{IN} = 24.0\text{V}$

*2 The voltage capable of starting discharge and keeping stable discharge.

When the voltage gradually increases, glow discharge will increase and FL tube terminals will be connected electrically.

2.8.3 Optical characteristics

Item	Symbol	Condition	Standard			Unit
			Min.	Typ.	Max.	
Surface brightness*1*2*4	B _p	Ta = 25 ± 3°C	100	130	-	nit
Distribution of brightness*1*3	ΔB _p	30~85%RH	-	-	35	%

*1 Measurement, 30 minutes after turning on of FL tube

FL inverter: INVC303 (Hitachi, Ltd.)

FL inverter input voltage: V_{IN} = 24.0V

LCD driving conditions: Optimum V_{opr}, f_{FRM} = 70 Hz

LCD display pattern: All ON display (all data = "H")

*2 Initial brightness of LCD Panel center

*3 Definition of ΔB_p (Distribution of brightness)

$$\Delta B_p = (B_p(\text{max.}) - B_p(\text{min.})) / B_p(\text{max.}) \times 100 (\%)$$

B_p(max.) = Maximum brightness of 5 measuring points

B_p(min.) = Minimum brightness of 5 measuring points

5 measuring points

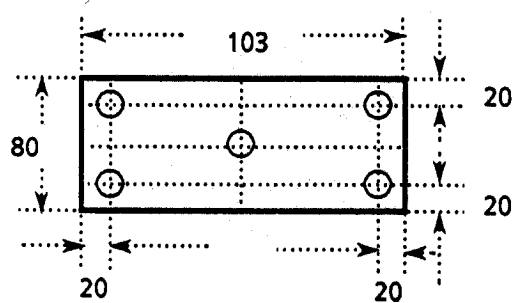

Unit: mm

*4 Ambient temperature affects brightness of FL tube. The reason is that radiation efficiency is depends on steam pressure of mercury enclosed in the tube. Practically the brightness is low in the cool.

As the steam pressure of mercury is also low just after turning on of FL tube, the brightness is low. The heat generated by FL tube will raise temperature on the tube surface, then brightness will increase with a rise in mercury steam pressure.

2.8.4 Life

Item	Condition	Standard		Unit
		Min.	Max.	
Life*1	Ta = 25 ± 3°C	10000	-	hrs

*1 FL driving condition: I_{FL} (lamp current) = 3.1 mArms

Time until the decreases to half of the initial brightness, or time until "not lit" because of increase in FL discharge start voltage.

3. RELIABILITY

3.1 Reliability

Test item	Test conditions	Evaluation and assessment
Operation at high temperature and humidity*1	40°C ± 2°C 90% RH for 500 hours	No abnormalities in functions*2 and appearance*3
Operation at high temperature*1	60°C ± 2°C for 500 hours	No abnormalities in functions*2 and appearance*3
Heat shock*1	- 20°C \rightleftharpoons + 60°C Left for 1 hour at each temperature, transition time 5 min, repeated 10 times	No abnormalities in functions*2 and appearance*3
Low temperature*1	- 20 ± 2°C for 500 hours	No abnormalities in functions*2 and appearance*3
Vibration	Sweep for 1 min at 10 Hz, 55 Hz, 10 Hz, amplitude 1.5 mm 2 hrs each in the X, Y, and Z directions	No abnormalities in functions*2 and appearance*3
Drop shock	Dropped onto a board from a height of 10 cm	No abnormalities in functions*2 and appearance*3

- *1 Evaluation and assessment are decided after 2 hours from each test is finished. There should be no dewing during test and 2-hour-storing.
- *2 Dissipation current, contrast and display functions
- *3 Polarizing filter deterioration, other appearance defects

3.2 Liquid crystal panel service life

100,000 hours minimum at 25°C ± 10°C, 65%RH maximum.

3.2 Definition of panel service life

- Cintrast increases 30% to initial value
- Current consumption increases three times higher to initial value
- Alignment deterioration occurs in LCD cell layer
- Unusual operation occurs in display functions

4. OPERATING INSTRUCTIONS

4.1 Input Signal Function

4.1.1 LCD

NO.	Symbol	Function
1	FLM	Frame signal (sync of display)
2	M	LCD drive signal (AC signal)
3	CL1	Display data latch signal
4	CL2	Display data shift clock
5	$\overline{\text{DISP OFF}}$	Display on/off control signal ("H":Display ON,"L":Display OFF)
6	D ₀	Display data
7	D ₁	Display data
8	D ₂	Display data
9	D ₃	Display data
10	V _{DD}	Power supply voltage : +5V
11	V _{SS}	GND : 0V
12	V _{LC}	Liquid crystal drive voltage : -24V
13	V _O	Liquid crystal drive voltage adjustment terminal
14	F _{GND}	(Frame GND) *

* F_{GND} is connected to the LCM metal vesel. Use this F_{GND} terminal to ground the LCM vesel.

4.1.2 FL backlight

NO.	Symbol	Function
1	V _{FLG}	Power supply voltage for FL backlight (GND)
2	NC	NC
3	V _{FL1}	Power supply voltage for FL backlight (High voltage)

4.2 Timing Characteristics

$T_a = 0 \sim 50^\circ\text{C}$, $V_{DD} = 5.0\text{V} \pm 5\%$, $V_{SS} = 0\text{V}$

Item	Symbol	Min.	Typ.	Max.	Unit
FLM cycle time	t_{CFLM}	13.6	14.3	15.0	mS
CL1 cycle time	t_{CCL1}	10	59.6	-	μS
CL1 "H" pulse width	t_{WCL1H}	50	-	-	nS
CL1 "L" pulse width	t_{WCL1L}	1000	-	-	nS
FLM setup time	t_{FLMS}	100	-	-	nS
FLM hold time	t_{FLMH}	100	-	-	nS
Input signal rise time	t_{R}	-	-	30	nS
Input signal fall time	t_{F}	-	-	30	nS
CL2 period	t_{CCL2}	125	-	-	nS
CL2 "H" pulse width	t_{WCL2H}	45	-	-	nS
CL2 "L" pulse width	t_{WCL2L}	45	-	-	nS
Data setup time	t_{DS}	20	-	-	nS
Data hold time	t_{DH}	20	-	-	nS
CL2 rise to CL1 rise time	t_{LD}	-	-	-	nS
CL2 fall to CL1 fall time	t_{SL}	80	-	-	nS
CL1 rise to CL2 rise time	t_{LS}	-	-	-	nS
CL1 fall to CL2 fall time	t_{LH}	80	-	-	nS

Timing chart 1 Timing of signal input into common driver

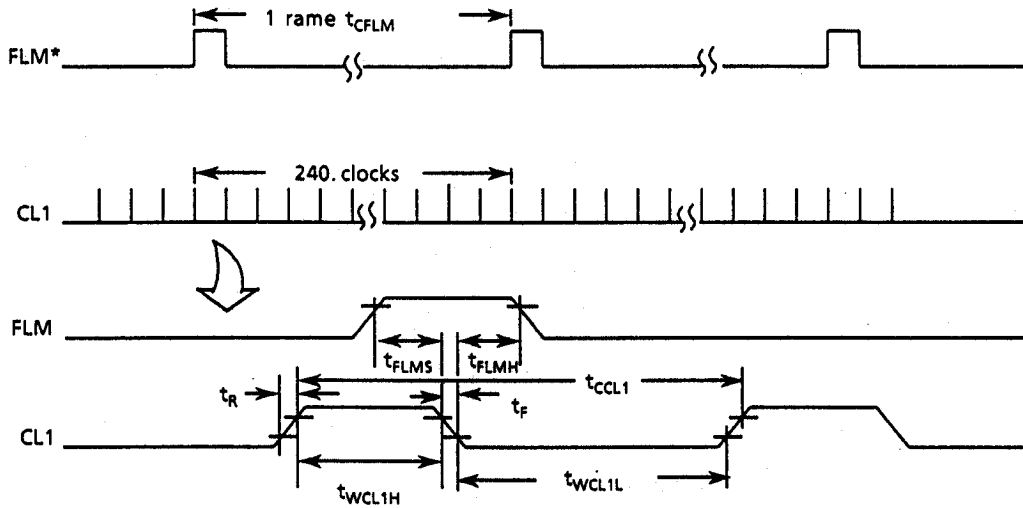

*FLM = First line marker

Timing chart 2 Timing of signal input into segment driver

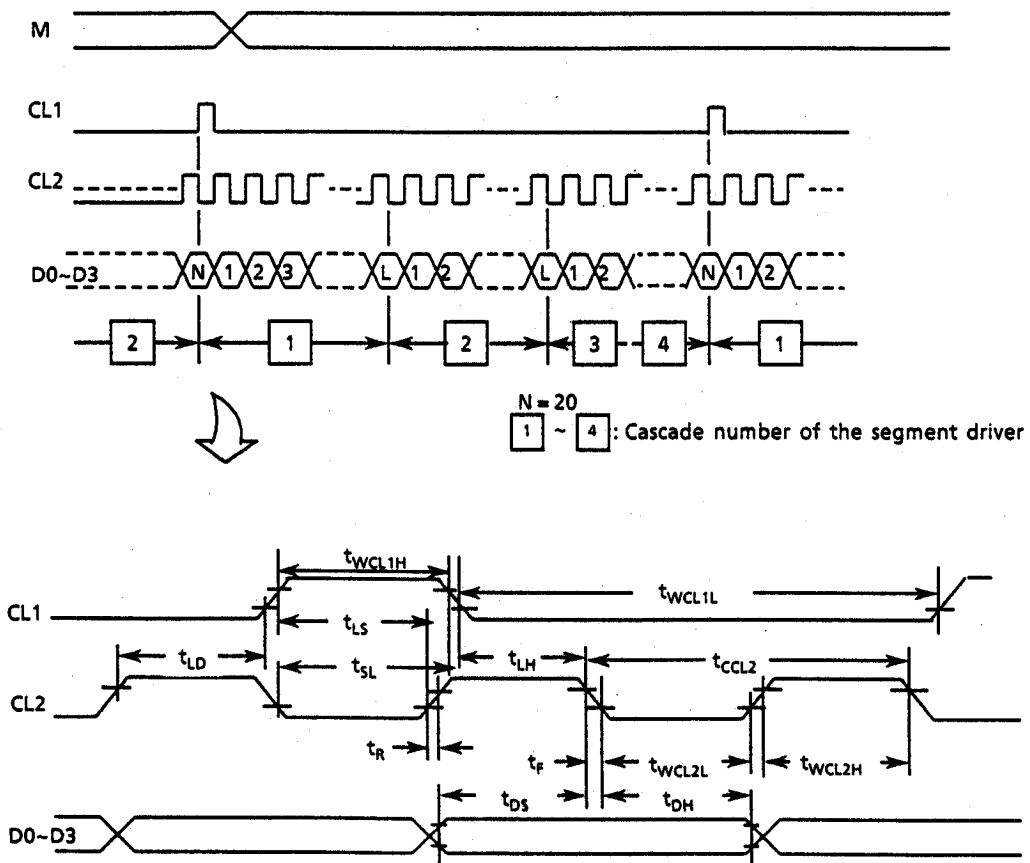

4.3 Vopr control circuit

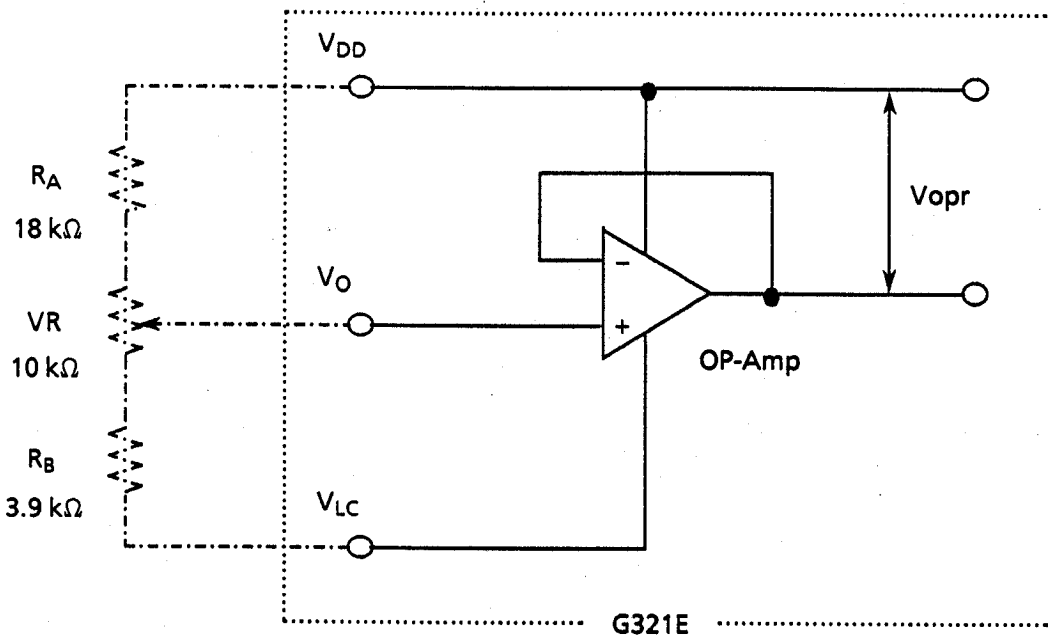

4.4 Power ON/OFF and Signal Input Timing

Power ON/OFF and signal input should be performed according to the timing shown in the figure below in order to prevent the damage of the LCD driving circuit and the LCD panel.

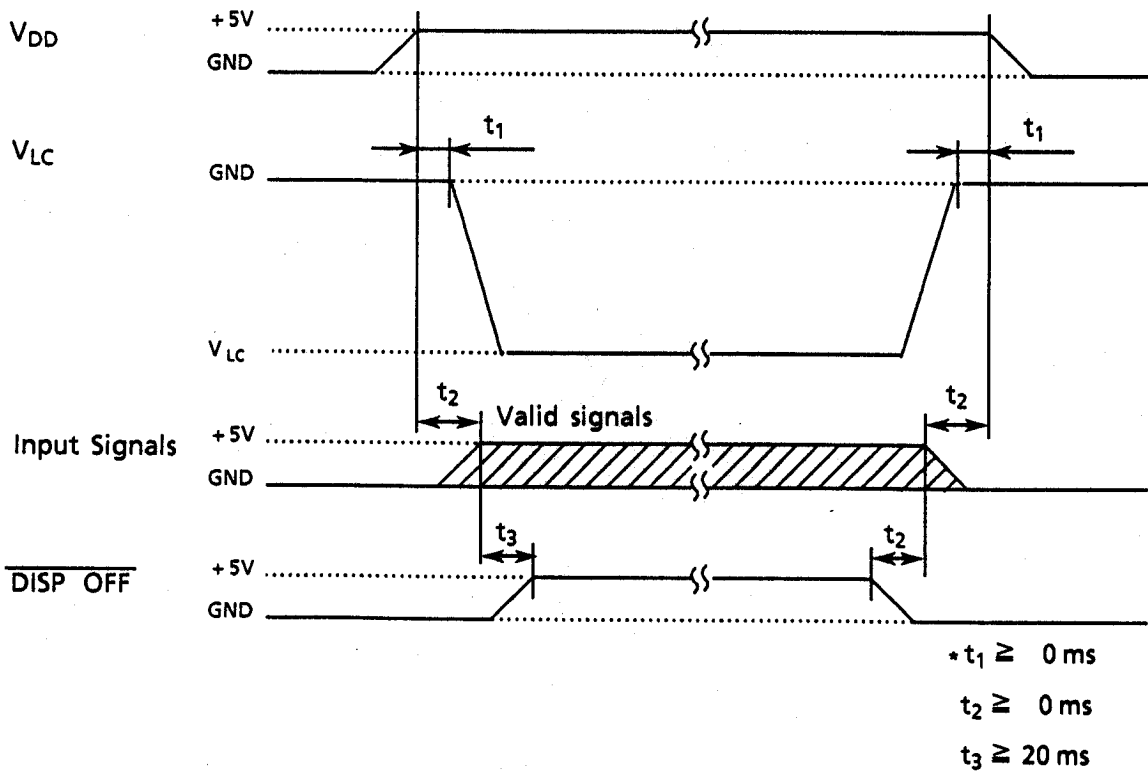

5. NOTES

Safety

- If the LCD panel breaks, be careful not to get the liquid crystal in your mouth.
- If the liquid crystal touches your skin or clothes, wash it off immediately using soap and plenty of water.
- While FL tube is energized, high voltage is supplied to the terminals. Do not touch the terminals. When connecting or disconnecting the FL cable, always turn off the power source.

Handling

- Avoid static electricity as this can damage the CMOS LSI.
- The LCD panel is plate glass; do not hit or crush it.
- Do not remove the panel or frame from the module.
- The polarizing plate of the display is very fragile; handle it very carefully
- Do not pull the cable for FL-backlight, as it may go off the unit.

Mounting and Design

- Mount the module by using the specified mounting part and holes.
- To protect the module from external pressure, recommend to leave a small gap by placing transparent plates (e.g. acrylic or glass) on the display surface, frame, and polarizing plate.

☆ Example

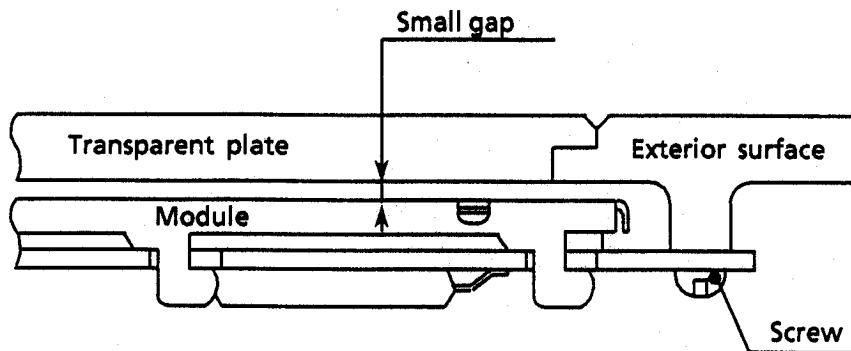

- Design the system so that no input signal is given unless the power-supply voltage is applied.
- Keep the module dry. Avoid condensation, otherwise the transparent electrodes may break.
- If the cable of FL tube is close to metal plate, metal foil or plating of case inside, stray capacity may cause voltage drop and deterioration of brightness and starting characteristics. Recommend consideration when designing case and positioning cable.

Storage

- Store the module in a dark place where the temperature is $25^{\circ}\text{C} \pm 10^{\circ}\text{C}$ and the humidity below 65% RH.
- Do not store the module near organic solvents or corrosive gases.
- Do not crush, shake, or jolt the module (including accessories).

Cleaning

- Do not wipe the polarizing plate with a dry cloth, as it may scratch the surface.
- Wipe the module gently with a soft cloth soaked with a petroleum benzine.
- Do not use ketonic solvents (ketone and acetone) or aromatic solvents (toluene and xylene), as they may damage the polarizing plate.

6. OPERATION PRECAUTIONS

We are not responsible for any accidents, injuries and damages that caused by ignoring NOTES.

Any changes that need to be made in this specification or any problems arising from it will be dealt with quickly by discussion between both companies.