

# Datasheet

**G32A1465**

**Arm<sup>®</sup> Cortex<sup>®</sup> -M4F core-based 32-bit MCU**

**Version: V1.2**

## 1 Product Characteristics

### ■ Core

- 32-bit Arm® Cortex® -M4F core with FPU
- Up to 112MHz working frequency

### ■ Memory and interface

- Flash with ECC: 1024KB
- SRAM with ECC: 128KB
- 64KB Data Flash with ECC
- 4KB CFGRAM for use as SRAM or analog EEPROM

### ■ Clock

- HSE: External 4~40MHz crystal oscillator
- HSI: Internal 48MHz RC oscillator
- LSI: Internal 8MHz RC oscillator
- LPO: Internal 128 kHz low-power RC oscillator
- SYSPLL: Main phase-locked loop up to 112MHz

### ■ Power supply and power supply management

- VDD range: 2.7V~5.5V
- VDDA range: VDD ~5.5V
- Power-on/low-power reset (POR/LVR) supported
- Low-voltage detector (LVD) supported

### ■ DMA

- A 16-channel DMA controller
- DMA channel multiplexer DMACHM

### ■ Debugging Interface

- JTAG
- SWD

### ■ Debugging function

- SWJ-DP
- DWT
- ITM

- TPIU

- FPB

### ■ I/O

- Up to 89 I/Os
- All I/O can be mapped to external interrupt vector

### ■ Communication peripherals

- 1×LPI2C interface
- 3×LPUART
- 3×LPSPI
- 3×CAN (all support CAN FD)
- 1×CFGIO configurable communication interface

### ■ Analog peripherals

- 2×12-bit ADC
- 1×comparator (built-in 8-bit DAC)

### ■ Timer

- 6×independent 16-bit timer CFGTMR, each offering 8 standard channels
- 1×16-bit LPTMR with flexible wake-up control
- 1×32-bit LPITMR with 4-channel
- 2×Programmable delay unit PDU
- 1×RTC, support calendar function, support alarm and regular wake-up from stop/standby mode

### ■ Safety and Security

- Cryptographic Services Engine (CSEc) implements a complete set of encryption capabilities described in the SHE (Secure Hardware Extension) functional specification
- 128-bit unique device ID
- CRC computing unit
- 1×internal watchdog (WDT)
- 1×external watchdog monitor (EWDT)
- System Memory Protection Unit (MPU)

- ECC on FLASH and SRAM
- **Chip package**
- LQFP64
- LQFP100

# Contents

<b>1</b>	<b>Product Characteristics .....</b>	<b>1</b>
<b>2</b>	<b>Product Information .....</b>	<b>5</b>
<b>3</b>	<b>System Block Diagram .....</b>	<b>5</b>
<b>4</b>	<b>Pin Configuration and Functions .....</b>	<b>7</b>
<b>5</b>	<b>Pin Multiplexing .....</b>	<b>14</b>
<b>6</b>	<b>Input Multiplexing Priority.....</b>	<b>22</b>
<b>7</b>	<b>Electrical Characteristics .....</b>	<b>33</b>
7.1	Test under general operating conditions.....	33
7.1.1	Absolute maximum rated value .....	33
7.1.2	Voltage and current operation requirements .....	34
7.1.3	Temperature operation characteristics .....	35
7.1.4	Power supply and ground pins .....	36
7.1.5	Low-voltage reset and detection system characteristics .....	38
7.1.6	Power mode conversion characteristics.....	38
7.1.7	Power Consumption .....	40
7.1.8	ESD and Latch-up protection characteristics .....	42
7.1.9	EMC radiated emission characteristics (to be tested).....	43
7.2	Memory and interface .....	43
7.2.1	Time characteristics of Flash command.....	43
7.2.2	Reliability specifications.....	46
7.3	Clock .....	47
7.3.1	Characteristics of external clock source.....	47
7.3.2	Electrical characteristics of system clock generator.....	49
7.3.3	Electrical characteristics of low-power oscillators .....	50
7.3.4	Electrical characteristics of system PLL .....	50
7.4	Clock frequency .....	50
7.5	Pin characteristics .....	51
7.5.1	AC electrical characteristics .....	51

7.5.2	General AC specifications .....	51
7.5.3	Characteristics of IO port.....	52
7.6	Communication peripherals .....	54
7.6.1	Electrical characteristics of LPUART.....	54
7.6.2	Electrical characteristics of LPSPI.....	54
7.6.3	Electrical characteristics of LPI2C.....	69
7.6.4	Electrical characteristics of CAN .....	69
7.7	Analog peripherals .....	69
7.7.1	ADC .....	69
7.7.2	Comparator with internal 8-bit DAC.....	74
7.8	Debugging module .....	78
7.8.1	SWD electrical specifications .....	78
7.8.2	Electrical characteristics of JTAG .....	83
7.9	Temperature characteristics.....	90
7.9.1	General precautions for specifications at maximum junction temperature .....	90
7.9.2	Temperature characteristics .....	91
<b>8</b>	<b>Package Information .....</b>	<b>93</b>
8.1	LQFP100 package information .....	93
8.2	LQFP64 package information .....	96
<b>9</b>	<b>Packaging Information .....</b>	<b>99</b>
9.1	Reel Packaging .....	99
9.2	Tray packaging.....	100
<b>10</b>	<b>Ordering Information .....</b>	<b>102</b>
<b>11</b>	<b>Commonly Used Function Module Denomination .....</b>	<b>104</b>
<b>12</b>	<b>Revision History .....</b>	<b>105</b>

## 2 Product Information

See the following table for G32A1465 product functions and peripheral configuration.

Table 1 Functions and Peripherals of G32A1465 Series Chips

Product		G32A1465							
Model		UAT0MLH	HAT0MLH	UAT0VLH	HAT0VLH	UAT0MLL	HAT0MLL	UAT0VLL	HAT0VLL
Package		LQFP64				LQFP100			
Core		Arm® 32-bit Cortex®-M4F							
Maximum operating frequency (MHz)		112	80	112	80	112	80	112	80
Working voltage		2.7-5.5V							
Flash (KB)		1024							
SRAM (KB)		128							
GPIOs		58				89			
Communication interface	LPUART	3							
	LPSPi	3							
	LPI2C	1							
	CAN	3							
	CFGIO	1							
Timer	16-bit CFGTMR	6(6*8)							
	16-bit LPTMR	1							
	32-bit LPITMR	1							
	WDT	1							
	EWDT	1							
	PDU	2							
Real-time clock		1							
12-bit ADC	Unit	2							
	External channel	16+13				16+16			
Analog comparator (8-bit DAC)		1(1)							
Operating temperature		Ambient temperature: -40°C to 125°C Junction temperature: -40°C to 135°C	Ambient temperature: -40°C to 105°C Junction temperature: -40°C to 125°C	Ambient temperature: -40°C to 125°C Junction temperature: -40°C to 135°C	Ambient temperature: -40°C to 105°C Junction temperature: -40°C to 125°C				

### 3 System Block Diagram

Figure 1 System Block Diagram

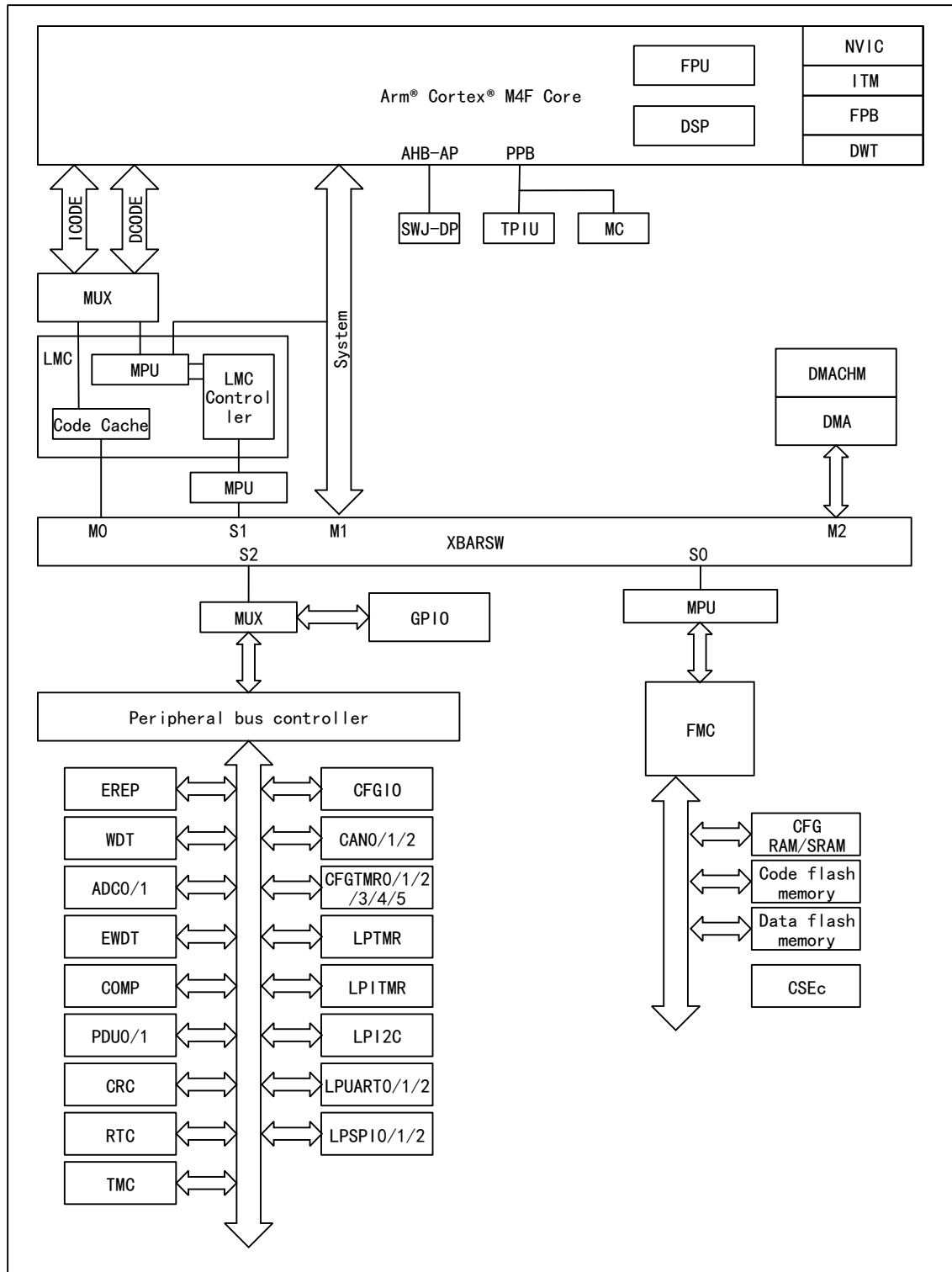

## 4 Pin Configuration and Functions

Figure 2 64-Pin LQFP Top View

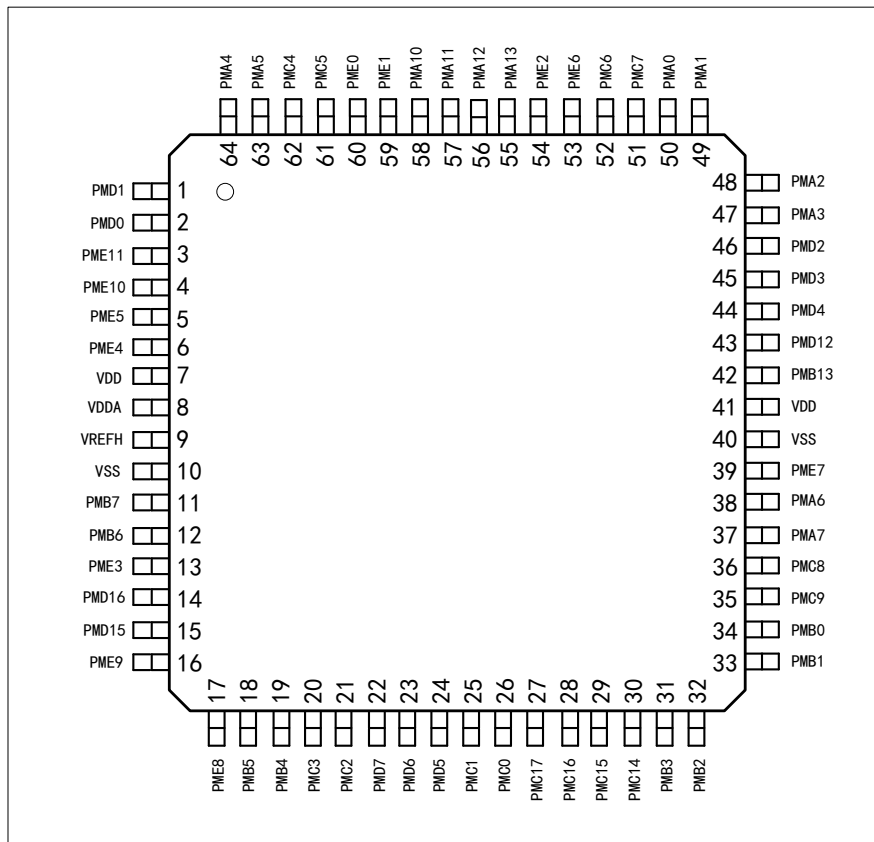

Table 2 Pin Functions

PIN		TYPE	DESCRIPTION
NAME	NO.		
PMA0	50	I/O	Default: ADC0_CH0/COMP0_IN0 (ADC0 channel 0/COMP0 input channel 0)
PMA1	49	I/O	Default: ADC0_CH1/COMP0_IN1 (ADC0 channel 1/COMP0 input channel 1)
PMA2	48	I/O	Default: ADC1_CH0 (ADC1 channel 0)
PMA3	47	I/O	Default: ADC1_CH1 (ADC1 channel 1)
PMA4	64	I/O	JTAG_TMS/SWD_DIO
PMA5	63	I/O	RESET_b
PMA6	38	I/O	Default: ADC0_CH2 (ADC0 channel 2)
PMA7	37	I/O	Default: ADC0_CH3 (ADC0 channel 3)
PMA10	58	I/O	JTAG_TDO/hoetm_TRACE_SWO



PIN		TYPE	DESCRIPTION
NAME	NO.		
PMA11	57	I/O	GPIO
PMA12	56	I/O	GPIO
PMA13	55	I/O	GPIO
PMB0	34	I/O	Default: ADC0_CH4/ADC1_CH14(ADC0 channel 4/ ADC1 channel 14)
PMB1	33	I/O	Default: ADC0_CH5/ADC1_CH15(ADC0 channel 5/ ADC1 channel 15)
PMB2	32	I/O	Default: ADC0_CH6(ADC0 channel 6)
PMB3	31	I/O	Default: ADC0_CH7(ADC0 channel 7)
PMB4	19	I/O	GPIO
PMB5	18	I/O	GPIO
PMB6	12	I/O	XTAL
PMB7	11	I/O	EXTAL
PMB12	43	I/O	Default: ADC1_CH7(ADC1 channel 7)
PMB13	42	I/O	Default: ADC1_CH8/ADC0_CH8(ADC1 channel 8/ADC0 channel 8)
PMC0	26	I/O	Default: ADC0_CH8(ADC0 channel 8)
PMC1	25	I/O	Default: ADC0_CH9(ADC0 channel 9)
PMC2	21	I/O	Default: ADC0_CH10/COMP0_IN5(ADC0 channel 10/COMP0 channel 5)
PMC3	20	I/O	Default: ADC0_CH11/COMP0_IN4(ADC0 channel 11/COMP0 channel 4)
PMC4	62	I/O	JTAG_TCLK/SWD_CLK
PMC5	61	I/O	JTAG_TDI
PMC6	52	I/O	Default: ADC1_CH4(ADC1 channel 4)
PMC7	51	I/O	Default: ADC1_CH5(ADC1 channel 5)
PMC8	36	I/O	GPIO
PMC9	35	I/O	GPIO
PMC14	30	I/O	Default: ADC0_CH12(ADC0 channel 12)
PMC15	29	I/O	Default: ADC0_CH13(ADC0 channel 13)
PMC16	28	I/O	Default: ADC0_CH14(ADC0 channel 14)

PIN		TYPE	DESCRIPTION
NAME	NO.		
PMC17	27	I/O	Default: ADC0_CH15(ADC0 channel 15)
PMD0	2	I/O	GPIO
PMD1	1	I/O	GPIO
PMD2	46	I/O	Default: ADC1_CH2(ADC1 channel 2)
PMD3	45	I/O	Default: ADC1_CH3(ADC1 channel 3)
PMD4	44	I/O	Default: ADC1_CH6(ADC1 channel 6)
PMD5	24	I/O	GPIO
PMD6	23	I/O	Default: COMP0_IN7(COMP0 channel 7)
PMD7	22	I/O	Default: COMP0_IN6(COMP0 channel 6)
PMD15	15	I/O	GPIO
PMD16	14	I/O	GPIO
PME0	60	I/O	GPIO
PME1	59	I/O	GPIO
PME2	54	I/O	Default: ADC1_CH10(ADC1 channel 10)
PME3	13	I/O	GPIO
PME4	6	I/O	GPIO
PME5	5	I/O	GPIO
PME6	53	I/O	Default: ADC1_CH11(ADC1 channel 11)
PME7	39	I/O	GPIO
PME8	17	I/O	Default: COMP0_IN3(COMP0 channel 3)
PME9	16	I/O	GPIO
PME10	4	I/O	GPIO
PME11	3	I/O	GPIO
VREFH	9	I	AD Reference Voltage
VDDA	8	I	Analog voltage, peripheral connection with VDD
VDD	7/41	I	Power supply voltage, peripheral connection
VSS	10/40	G	GND, peripheral connection

Figure 3 100-Pin LQFP Top View

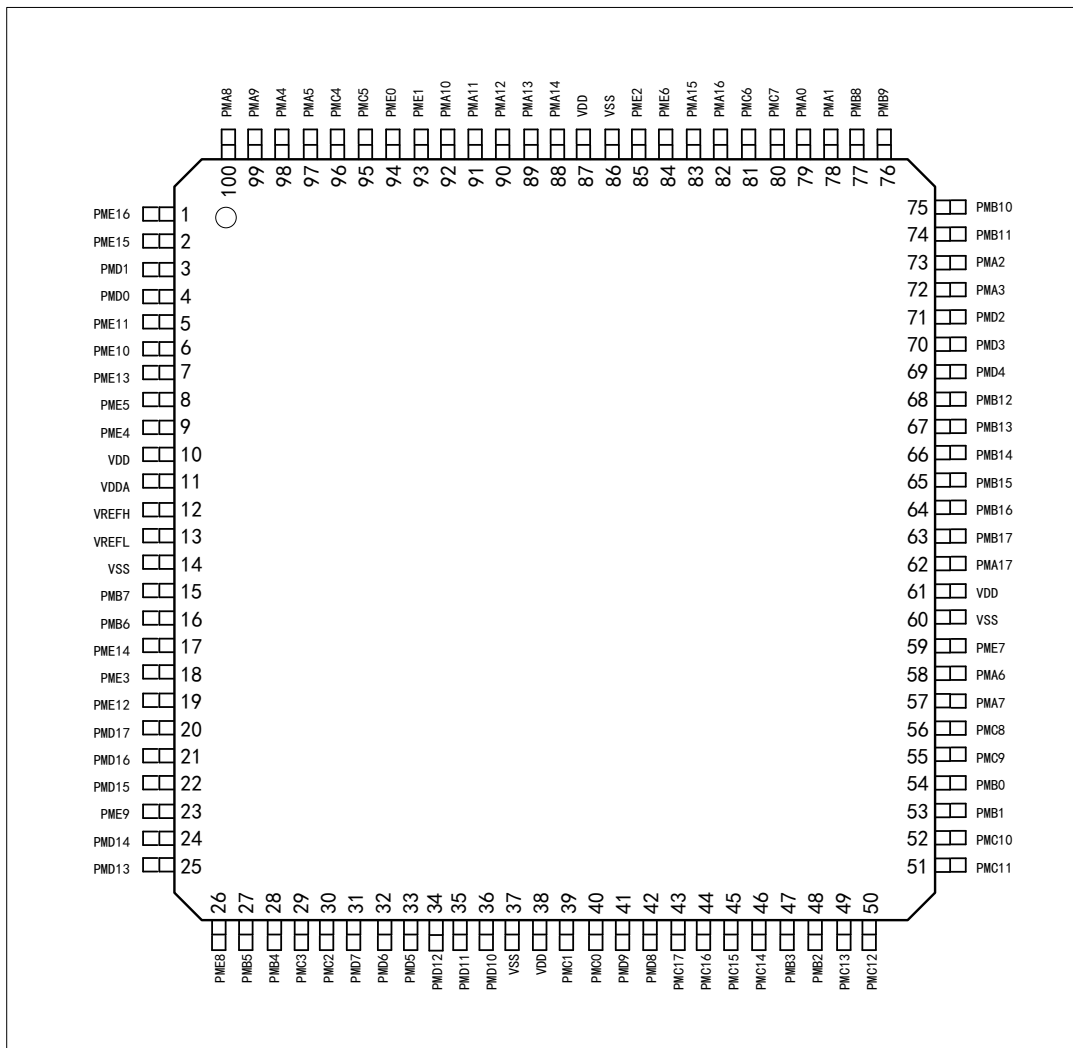

Table 3 Pin Functions

PIN		TYPE	DESCRIPTION
NAME	NO.		
PMA0	79	I/O	Default: ADC0_CH0/COMP0_IN0 (ADC0 channel 0/COMP0 input channel 0)
PMA1	78	I/O	Default: ADC0_CH1/COMP0_IN1 (ADC0 channel 1/COMP0 input channel 1)
PMA2	73	I/O	Default: ADC1_CH0 (ADC1 channel 0)
PMA3	72	I/O	Default: ADC1_CH1 (ADC1 channel 1)
PMA4	98	I/O	JTAG_TMS/SWD_DIO
PMA5	97	I/O	RESET_b
PMA6	58	I/O	Default: ADC0_CH2 (ADC0 channel 2)
PMA7	57	I/O	Default: ADC0_CH3 (ADC0 channel 3)
PMA8	100	I/O	GPIO

PIN		TYPE	DESCRIPTION
NAME	NO.		
PMA9	99	I/O	GPIO
PMA10	92	I/O	JTAG_TDO/noetm_TRACE_SWO
PMA11	91	I/O	GPIO
PMA12	90	I/O	GPIO
PMA13	89	I/O	GPIO
PMA14	88	I/O	GPIO
PMA15	83	I/O	Default: ADC1_CH12 (ADC1 channel 12)
PMA16	82	I/O	Default: ADC1_CH13 (ADC1 channel 13)
PMA17	62	I/O	GPIO
PMB0	54	I/O	Default: ADC0_CH4/ADC1_CH14(ADC0 channel 4/ ADC1 channel 14)
PMB1	53	I/O	Default: ADC0_CH5/ADC1_CH15(ADC0 channel 5/ ADC1 channel 15)
PMB2	48	I/O	Default: ADC0_CH6(ADC0 channel 6)
PMB3	47	I/O	Default: ADC0_CH7(ADC0 channel 7)
PMB4	28	I/O	GPIO
PMB5	27	I/O	GPIO
PMB6	16	I/O	XTAL
PMB7	15	I/O	EXTAL
PMB8	77	I/O	GPIO
PMB9	76	I/O	GPIO
PMB10	75	I/O	GPIO
PMB11	74	I/O	GPIO
PMB12	68	I/O	Default: ADC1_CH7(ADC1 channel 7)
PMB13	67	I/O	Default: ADC1_CH8/ADC0_CH8(ADC1 channel 8/ADC0 channel 8)
PMB14	66	I/O	Default: ADC1_CH9/ADC0_CH9(ADC1 channel 9/ADC0 channel 9)
PMB15	65	I/O	Default: ADC1_CH14(ADC1 channel 14)
PMB16	64	I/O	Default: ADC1_CH15(ADC1 channel 15)
PMB17	63	I/O	GPIO
PMC0	40	I/O	Default: ADC0_CH8(ADC0 channel 8)
PMC1	39	I/O	Default: ADC0_CH9(ADC0 channel 9)
PMC2	30	I/O	Default: ADC0_CH10/COMP0_IN5(ADC0 channel 10/COMP0 channel 5)

PIN		TYPE	DESCRIPTION
NAME	NO.		
PMC3	29	I/O	Default: ADC0_CH11/COMP0_IN4(ADC0 channel 11/COMP0 channel 4)
PMC4	96	I/O	JTAG_TCLK/SWD_CLK
PMC5	95	I/O	JTAG_TDI
PMC6	81	I/O	Default: ADC1_CH4(ADC1 channel 4)
PMC7	80	I/O	Default: ADC1_CH5(ADC1 channel 5)
PMC8	56	I/O	GPIO
PMC9	55	I/O	GPIO
PMC10	52	I/O	GPIO
PMC11	51	I/O	GPIO
PMC12	50	I/O	GPIO
PMC13	49	I/O	GPIO
PMC14	46	I/O	Default: ADC0_CH12(ADC0 channel 12)
PMC15	45	I/O	Default: ADC0_CH13(ADC0 channel 13)
PMC16	44	I/O	Default: ADC0_CH14(ADC0 channel 14)
PMC17	43	I/O	Default: ADC0_CH15(ADC0 channel 15)
PMD0	4	I/O	GPIO
PMD1	3	I/O	GPIO
PMD2	71	I/O	Default: ADC1_CH2(ADC1 channel 2)
PMD3	70	I/O	Default: ADC1_CH3(ADC1 channel 3)
PMD4	69	I/O	Default: ADC1_CH6(ADC1 channel 6)
PMD5	33	I/O	GPIO
PMD6	32	I/O	Default: COMP0_IN7(COMP0 channel 7)
PMD7	31	I/O	Default: COMP0_IN6(COMP0 channel 6)
PMD8	42	I/O	GPIO
PMD9	41	I/O	GPIO
PMD10	36	I/O	GPIO
PMD11	35	I/O	GPIO
PMD12	34	I/O	GPIO
PMD13	25	I/O	GPIO
PMD14	24	I/O	GPIO
PMD15	22	I/O	GPIO

PIN		TYPE	DESCRIPTION
NAME	NO.		
PMD16	21	I/O	GPIO
PMD17	20	I/O	GPIO
PME0	94	I/O	GPIO
PME1	93	I/O	GPIO
PME2	85	I/O	Default: ADC1_CH10(ADC1 channel 10)
PME3	18	I/O	GPIO
PME4	9	I/O	GPIO
PME5	8	I/O	GPIO
PME6	84	I/O	Default: ADC1_CH11(ADC1 channel 11)
PME7	59	I/O	GPIO
PME8	26	I/O	Default: COMP0_IN3(COMP0 channel 3)
PME9	23	I/O	GPIO
PME10	6	I/O	GPIO
PME11	5	I/O	GPIO
PME12	19	I/O	GPIO
PME13	7	I/O	GPIO
PME14	17	I/O	GPIO
PME15	2	I/O	GPIO
PME16	1	I/O	GPIO
VREFH	12	I	AD Reference Voltage
VDDA	11	I	Analog voltage, peripheral connection with VDD
VDD	10/38/6 1/87	I	Power supply voltage, peripheral connection
VREFL	13	G	AD Reference GND
VSS	86/60/3 7/14	G	GND, peripheral connection

## 5 Pin Multiplexing

Table 4 Pin Multiplexing

G32A1465		GPIO	AF0	AF1	AF2	AF3	AF4	AF5	AF6	AF7
64pin LQFP	100pin LQFP									
-	1	PME16	-	PME16	LPUART1_RTS	LPSPi2_SIN	CFGTM2R2_CH7	CFGTM4R4_FLT0	CFGIO_D3	TMC_OUT7
-	2	PME15	-	PME15	LPUART1_CTS	LPSPi2_SCK	CFGTM2R2_CH6	CFGTM4R4_FLT1	CFGIO_D2	TMC_OUT6
1	3	PMD1	-	PMD1	CFGTM2R2_CH3	LPSPi1_SIN	CFGTM2R2_CH1	-	CFGIO_D1	TMC_OUT2
2	4	PMD0	-	PMD0	CFGTM2R2_CH2	LPSPi1_SCK	CFGTM2R2_CH0	-	CFGIO_D0	TMC_OUT1
3	5	PME11	-	PME11	LPSPi2_PCS0	LPTMR0_ALT1	CFGTM2R2_CH5	-	CFGIO_D5	TMC_OUT5
4	6	PME10	-	PME10	CLKOUT	LPSPi2_PCS1	CFGTM2R2_CH4	-	CFGIO_D4	TMC_OUT4
-	7	PME13	-	PME13	CFGTM4R4_CH5	LPSPi2_PCS2	CFGTM2R2_FLT0	-	-	-
5	8	PME5	-	PME5	TCLK2	CFGTM2R2_QD_PHA	CFGTM2R2_CH3	CAN0_TX	CFGIO_D7	EWDT_IN
6	9	PME4	-	PME4	-	CFGTM2R2_QD_PHB	CFGTM2R2_CH2	CAN0_RX	CFGIO_D6	EWDT_OUT_b
7	10	VDD	VDD	-	-	-	-	-	-	-
8	11	VDDA	VDDA	-	-	-	-	-	-	-
9	12	VREFH	VREFH	-	-	-	-	-	-	-
-	13	VREFL	VREFL	-	-	-	-	-	-	-
10	14	VSS	VSS	-	-	-	-	-	-	-
11	15	PMB7	EXTAL	PMB7	LPI2C0_SCL	-	-	-	-	-
12	16	PMB6	XTAL	PMB6	LPI2C0_SDA	-	-	-	-	-

G32A1465		GPIO	AF0	AF1	AF2	AF3	AF4	AF5	AF6	AF7
64pin LQFP	100pin LQFP									
-	17	PME14	-	PME14	CFGTMR0_FLT1	-	CFGTMR2_FLT1	-	-	-
13	18	PME3	-	PME3	CFGTMR0_FLT0	LPUART2_RTS	CFGTMR2_FLT0	-	TMC_IN6	COMP0_OUT
-	19	PME12	-	PME12	CFGTMR0_FLT3	LPUART2_TX	CFGTMR5_FLT0	-	-	-
-	20	PMD17	-	PMD17	CFGTMR0_FLT2	LPUART2_RX	CFGTMR5_FLT1	-	-	-
14	21	PMD16	-	PMD16	CFGTMR0_CH1	-	LPSPi0_SIN	COMP0_RRT	-	-
15	22	PMD15	-	PMD15	CFGTMR0_CH0	-	LPSPi0_SCK	-	-	-
16	23	PME9	-	PME9	CFGTMR0_CH7	LPUART2_CTS	-	-	-	-
-	24	PMD14	-	PMD14	CFGTMR2_CH5	LPUART1_TX	-	-	-	CLKOUT
-	25	PMD13	-	PMD13	CFGTMR2_CH4	LPUART1_RX	-	-	-	RTC_CLKOUT
17	26	PME8	COMP0_IN3	PME8	CFGTMR0_CH6	-	-	-	-	-
18	27	PMB5	-	PMB5	CFGTMR0_CH5	LPSPi0_PCS1	LPSPi0_PCS0	CLKOUT	TMC_IN0	-
19	28	PMB4	-	PMB4	CFGTMR0_CH4	LPSPi0_SOUT	-	-	TMC_IN1	-
20	29	PMC3	ADC0_C H11/COMP0_IN4	PMC3	CFGTMR0_CH3	CAN0_TX	LPUART0_TX	-	-	-



G32A1465		GPIO	AF0	AF1	AF2	AF3	AF4	AF5	AF6	AF7
64pin LQFP	100pin LQFP									
21	30	PMC2	ADC0_C H10/CO MP0_IN5	PMC2	CFGTMR0_CH2	CAN0_RX	LPUART0_RX	-	-	-
22	31	PMD7	COMP0_ IN6	PMD7	LPUART2_TX	-	CFGTMR2_FLT3	-	-	-
23	32	PMD6	COMP0_ IN7	PMD6	LPUART2_RX	-	CFGTMR2_FLT2	-	-	-
24	33	PMD5	-	PMD5	CFGTMR2_CH3	LPTMR0_ALT2	CFGTMR2_FLT1	-	TMC_IN7	-
-	34	PMD12	-	PMD12	CFGTMR2_CH2	-	-	-	LPUART2_RT S	-
-	35	PMD11	-	PMD11	CFGTMR2_CH1	CFGTMR2_QD_PHA	-	-	LPUART2_CT S	-
-	36	PMD10	-	PMD10	CFGTMR2_CH0	CFGTMR2_QD_PHB	-	-	CLKOUT	-
-	37	VSS	VSS	-	-	-	-	-	-	-
-	38	VDD	VDD	-	-	-	-	-	-	-
25	39	PMC1	ADC0_C H9	PMC1	CFGTMR0_CH1	LPSPi2_SOUT	-	-	CFGTMR1_C H7	-
26	40	PMC0	ADC0_C H8	PMC0	CFGTMR0_CH0	LPSPi2_SIN	-	-	CFGTMR1_C H6	-
-	41	PMD9	-	PMD9	-	CFGIO_D0	CFGTMR2_FLT3	-	CFGTMR1_C H5	-
-	42	PMD8	-	PMD8	-	-	CFGTMR2_FLT2	CFGIO_D1	CFGTMR1_C H4	-

G32A1465		GPIO	AF0	AF1	AF2	AF3	AF4	AF5	AF6	AF7
64pin LQFP	100pin LQFP									
27	43	PMC17	ADC0_C H15	PMC17	CFGTMR1_FLT 3	CAN2_TX	-	-	-	-
28	44	PMC16	ADC0_C H14	PMC16	CFGTMR1_FLT 2	CAN2_RX	-	-	-	-
29	45	PMC15	ADC0_C H13	PMC15	CFGTMR1_CH3	LPSPi2_SCK	-	-	TMC_IN8	-
30	46	PMC14	ADC0_C H12	PMC14	CFGTMR1_CH2	LPSPi2_PCS0	-	-	TMC_IN9	-
31	47	PMB3	ADC0_C H7	PMB3	CFGTMR1_CH1	LPSPi0_SIN	CFGTMR1_QD_PH A	-	TMC_IN2	-
32	48	PMB2	ADC0_C H6	PMB2	CFGTMR1_CH0	LPSPi0_SCK	CFGTMR1_QD_PH B	-	TMC_IN3	-
-	49	PMC13	-	PMC13	CFGTMR3_CH7	CFGTMR2_CH7	LPUART2_RTS	-	-	-
-	50	PMC12	-	PMC12	CFGTMR3_CH6	CFGTMR2_CH6	LPUART2_CTS	-	-	-
-	51	PMC11	-	PMC11	CFGTMR3_CH5	CFGTMR4_CH2	-	-	TMC_IN10	-
-	52	PMC10	-	PMC10	CFGTMR3_CH4	-	-	-	TMC_IN11	-
33	53	PMB1	ADC0_C H5/ADC 1_CH15	PMB1	LPUART0_TX	LPSPi0_SOUT	TCLK0	CAN0_TX	CFGTMR4_C H5	-
34	54	PMB0	ADC0_C H4/ADC 1_CH14	PMB0	LPUART0_RX	LPSPi0_PCS0	LPTMR0_ALT3	CAN0_RX	CFGTMR4_C H6	-

G32A1465		GPIO	AF0	AF1	AF2	AF3	AF4	AF5	AF6	AF7
64pin LQFP	100pin LQFP									
35	55	PMC9	-	PMC9	LPUART1_TX	CFGTMR1_FLT1	CFGTMR5_CH0	-	LPUART0_RT S	-
36	56	PMC8	-	PMC8	LPUART1_RX	CFGTMR1_FLT0	CFGTMR5_CH1	-	LPUART0_CT S	-
37	57	PMA7	ADC0_C H3	PMA7	CFGTMR0_FLT 2	CFGTMR5_CH3	RTC_CLKIN	-	LPUART1_RT S	-
38	58	PMA6	ADC0_C H2	PMA6	CFGTMR0_FLT 1	LPSP11_PCS1	CFGTMR5_CH5	-	LPUART1_CT S	-
39	59	PME7	-	PME7	CFGTMR0_CH7	CFGTMR3_FLT0	-	-	-	-
40	60	VSS	VSS	-	-	-	-	-	-	-
41	61	VDD	VDD	-	-	-	-	-	-	-
-	62	PMA17	-	PMA17	CFGTMR0_CH6	CFGTMR3_FLT0	EWDT_OUT_b	CFGTMR5_ FLT0	-	-
-	63	PMB17	-	PMB17	CFGTMR0_CH5	LPSP11_PCS3	CFGTMR5_FLT1	-	-	-
-	64	PMB16	ADC1_C H15	PMB16	CFGTMR0_CH4	LPSP11_SOUT	-	-	-	-
-	65	PMB15	ADC1_C H14	PMB15	CFGTMR0_CH3	LPSP11_SIN	-	-	-	-
-	66	PMB14	ADC1_C H9/ADC 0_CH9	PMB14	CFGTMR0_CH2	LPSP11_SCK	-	-	-	-

G32A1465		GPIO	AF0	AF1	AF2	AF3	AF4	AF5	AF6	AF7
64pin LQFP	100pin LQFP									
42	67	PMB13	ADC1_C H8/ADC 0_CH8	PMB13	CFGTMR0_CH1	CFGTMR3_FLT1	CAN2_TX	-	-	-
43	68	PMB12	ADC1_C H7	PMB12	CFGTMR0_CH0	CFGTMR3_FLT2	CAN2_RX	-	-	-
44	69	PMD4	ADC1_C H6	PMD4	CFGTMR0_FLT 3	CFGTMR3_FLT3	-	-	-	-
45	70	PMD3	ADC1_C H3	PMD3	CFGTMR3_CH5	LPSP11_PCS0	CFGIO_D5	CFGIO_D7	TMC_IN4	NMI_b
46	71	PMD2	ADC1_C H2	PMD2	CFGTMR3_CH4	LPSP11_SOUT	CFGIO_D4	CFGIO_D6	TMC_IN5	-
47	72	PMA3	ADC1_C H1	PMA3	CFGTMR3_CH1	LPI2C0_SCL	EWDI_IN	CFGIO_D5	LPUART0_TX	-
48	73	PMA2	ADC1_C H0	PMA2	CFGTMR3_CH0	LPI2C0_SDA	EWDI_OUT_b	CFGIO_D4	LPUART0_RX	-
-	74	PMB11	-	PMB11	CFGTMR3_CH3	LPI2C0_HREQ	-	-	-	-
-	75	PMB10	-	PMB10	CFGTMR3_CH2	LPI2C0_SDAS	-	-	-	-
-	76	PMB9	-	PMB9	CFGTMR3_CH1	LPI2C0_SCLS	-	-	-	-
-	77	PMB8	-	PMB8	CFGTMR3_CH0	-	-	-	-	-
49	78	PMA1	ADC0_C H1/COM P0_IN1	PMA1	CFGTMR1_CH1	LPI2C0_SDAS	CFGIO_D3	CFGTMR1_ QD_PHA	LPUART0_RT S	TMC_OUT0

G32A1465		GPIO	AF0	AF1	AF2	AF3	AF4	AF5	AF6	AF7
64pin LQFP	100pin LQFP									
50	79	PMA0	ADC0_C H0/COM P0_IN0	PMA0	CFGTMR2_CH1	LPI2C0_SCLS	CFGIO_D2	CFGTMR2_ QD_PHA	LPUART0_CT S	TMC_OUT3
51	80	PMC7	ADC1_C H5	PMC7	LPUART1_TX	CAN1_TX	CFGTMR3_CH3	-	CFGTMR1_Q D_PHA	-
52	81	PMC6	ADC1_C H4	PMC6	LPUART1_RX	CAN1_RX	CFGTMR3_CH2	-	CFGTMR1_Q D_PHB	-
-	82	PMA16	ADC1_C H13	PMA16	CFGTMR1_CH3	LPSP11_PCS2	-	-	-	-
-	83	PMA15	ADC1_C H12	PMA15	CFGTMR1_CH2	LPSP10_PCS3	LPSP12_PCS3	-	-	-
53	84	PME6	ADC1_C H11	PME6	LPSP10_PCS2	-	CFGTMR3_CH7	-	LPUART1_RT S	-
54	85	PME2	ADC1_C H10	PME2	LPSP10_SOUT	LPTMR0_ALT3	CFGTMR3_CH6	-	LPUART1_CT S	-
-	86	VSS	VSS	-	-	-	-	-	-	-
-	87	VDD	VDD	-	-	-	-	-	-	-
-	88	PMA14	-	PMA14	CFGTMR0_FLT 0	CFGTMR3_FLT1	EWDT_IN	-	CFGTMR1_FL T0	-
55	89	PMA13	-	PMA13	CFGTMR1_CH7	CAN1_TX	-	-	CFGTMR2_Q D_PHA	-
56	90	PMA12	-	PMA12	CFGTMR1_CH6	CAN1_RX	-	-	CFGTMR2_Q D_PHB	-

G32A1465		GPIO	AF0	AF1	AF2	AF3	AF4	AF5	AF6	AF7
64pin LQFP	100pin LQFP									
57	91	PMA11	-	PMA11	CFGTMR1_CH5	-	CFGIO_D1	COMP0_RRT	-	-
58	92	PMA10	-	PMA10	CFGTMR1_CH4	-	CFGIO_D0	-	-	JTAG_TDO/noretm_TRACE_SWO
59	93	PME1	-	PME1	LPSP10_SIN	LPI2C0_HREQ	-	LPSP11_PC S0	CFGTMR1_FL T1	-
60	94	PME0	-	PME0	LPSP10_SCK	TCLK1	-	LPSP11_SO UT	CFGTMR1_FL T2	-
61	95	PMC5	-	PMC5	CFGTMR2_CH0	RTC_CLKOUT	-	-	CFGTMR2_Q D_PHB	JTAG_TDI
62	96	PMC4	COMP0_IN2	PMC4	CFGTMR1_CH0	RTC_CLKOUT	-	EWDT_IN	CFGTMR1_Q D_PHB	JTAG_TCLK/SWD_CLK
63	97	PMA5	-	PMA5	-	TCLK1	-	-	-	RESET_b
64	98	PMA4	-	PMA4	-	-	COMP0_OUT	EWDT_OUT_b	-	JTAG_TMS/SWD_DIO
-	99	PMA9	-	PMA9	LPUART2_TX	LPSP12_PCS0	CFGIO_D7	CFGTMR3_FLT2	CFGTMR1_FL T3	CFGTMR4_FL T0
-	100	PMA8	-	PMA8	LPUART2_RX	LPSP12_SOUT	CFGIO_D6	CFGTMR3_FLT3	CFGTMR4_FL T1	-

## 6 Input Multiplexing Priority

Input multiplexing priority is shown in the table below:

Table 5 Input multiplexing priority

Function	Priority	PM_PINCTRLx[ MUXCTRL]	Number of 100 Pins	Number of 64 Pins	Pin
CAN0_RX	1	0000 0011	30	21	PMC2
	2	0000 0101	9	6	PME4
	3	0000 0101	54	34	PMB0
	4	-	-	-	Disable low
CAN1_RX	1	0000 0011	81	52	PMC6
	2	0000 0011	90	56	PMA12
	3	-	-	-	Disable low
CAN2_RX	1	0000 0011	44	28	PMC16
	2	0000 0100	68	43	PMB12
	3	-	-	-	Disable low
EWDT_IN	1	0000 0100	72	47	PMA3
	2	0000 0101	96	62	PMC4
	3	0000 0100	88	-	PMA14
	4	0000 0111	8	5	PME5
	5	-	-	-	Disable low
TCLK1	1	0000 0011	94	60	PME0
	2	0000 0011	97	63	PMA5
	3	-	-	-	Disable low
CFGTMR0_CH0	1	0000 0010	68	43	PMB12
	2	0000 0010	22	15	PMD15
	3	0000 0010	40	26	PMC0
	4	-	-	-	Disable low
CFGTMR0_CH1	1	0000 0010	39	25	PMC1
	2	0000 0010	67	42	PMB13
	3	0000 0010	21	14	PMD16
	4	-	-	-	Disable low
CFGTMR0_CH2	1	0000 0010	4	2	PMD0
	2	0000 0010	30	21	PMC2

Function	Priority	PM_PINCTRLx[ MUXCTRL]	Number of 100 Pins	Number of 64 Pins	Pin
	3	0000 0010	66	-	PMB14
	4	-	-	-	Disable low
CFGTMR0_CH3	1	0000 0010	65	-	PMB15
	2	0000 0010	3	1	PMD1
	3	0000 0010	29	20	PMC3
	4	-	-	-	Disable low
CFGTMR0_CH4	1	0000 0010	28	19	PMB4
	2	0000 0010	64	-	PMB16
	3	-	-	-	Disable low
CFGTMR0_CH5	1	0000 0010	27	18	PMB5
	2	0000 0010	63	-	PMB17
	3	-	-	-	Disable low
CFGTMR0_CH6	1	0000 0010	26	17	PME8
	2	0000 0010	62	-	PMA17
	3	-	-	-	Disable low
CFGTMR0_CH7	1	0000 0010	23	16	PME9
	2	0000 0010	59	39	PME7
	3	-	-	-	Disable low
CFGTMR0_FLT0	1	0000 0010	88	-	PMA14
	2	0000 0010	18	13	PME3
	3	-	-	-	Disable low
CFGTMR0_FLT1	1	0000 0010	58	38	PMA6
	2	0000 0010	17	-	PME14
	3	-	-	-	Disable low
CFGTMR0_FLT2	1	0000 0010	57	37	PMA7
	2	0000 0010	20	-	PMD17
	3	-	-	-	Disable low
CFGTMR0_FLT3	1	0000 0010	69	44	PMD4
	2	0000 0010	19	-	PME12
	3	-	-	-	Disable low
CFGTMR1_CH0	1	0000 0010	48	32	PMB2
	2	0000 0010	96	62	PMC4



Function	Priority	PM_PINCTRLx[ MUXCTRL]	Number of 100 Pins	Number of 64 Pins	Pin
	3	-	-	-	Disable low
CFGTMR1_CH1	1	0000 0010	78	49	PMA1
	2	0000 0010	47	31	PMB3
	3	-	-	-	Disable low
CFGTMR1_CH2	1	0000 0010	46	30	PMC14
	2	0000 0010	83	-	PMA15
	3	-	-	-	Disable low
CFGTMR1_CH3	1	0000 0010	45	29	PMC15
	2	0000 0010	82	-	PMA16
	3	-	-	-	Disable low
CFGTMR1_CH4	1	0000 0110	42	-	PMD8
	2	0000 0010	92	58	PMA10
	3	-	-	-	Disable low
CFGTMR1_CH5	1	0000 0010	91	57	PMA11
	2	0000 0110	41	-	PMD9
	3	-	-	-	Disable low
CFGTMR1_CH6	1	0000 0010	90	56	PMA12
	2	0000 0110	40	26	PMC0
	3	-	-	-	Disable low
CFGTMR1_CH7	1	0000 0110	39	25	PMC1
	2	0000 0010	89	55	PMA13
	3	-	-	-	Disable low
CFGTMR1_FLT0	1	0000 0110	88	-	PMA14
	2	0000 0011	56	36	PMC8
	3	-	-	-	Disable low
CFGTMR1_FLT1	1	0000 0110	93	59	PME1
	2	0000 0011	55	35	PMC9
	3	-	-	-	Disable low
CFGTMR1_FLT2	1	0000 0010	44	28	PMC16
	2	0000 0110	94	60	PME0
	3	-	-	-	Disable low
CFGTMR1_FLT3	1	0000 0110	99	-	PMA9

Function	Priority	PM_PINCTRLx[ MUXCTRL]	Number of 100 Pins	Number of 64 Pins	Pin
	2	0000 0010	43	27	PMC17
	3	-	-	-	Disable low
CFGTMR1_QD_PH A	1	0000 0101	78	49	PMA1
	2	0000 0100	47	31	PMB3
	3	0000 0110	80	51	PMC7
	4	-	-	-	Disable low
CFGTMR1_QD_PH B	1	0000 0100	48	32	PMB2
	2	0000 0110	96	62	PMC4
	3	0000 0110	81	52	PMC6
	4	-	-	-	Disable low
CFGTMR2_CH0	1	0000 0100	4	2	PMD0
	2	0000 0010	95	61	PMC5
	3	0000 0010	36	-	PMD10
	4	-	-	-	Disable low
CFGTMR2_CH1	1	0000 0100	3	1	PMD1
	2	0000 0010	79	50	PMA0
	3	0000 0010	35	-	PMD11
	4	-	-	-	Disable low
CFGTMR2_CH2	1	0000 0010	34	-	PMD12
	2	0000 0100	9	6	PME4
	3	-	-	-	Disable low
CFGTMR2_CH3	1	0000 0100	8	5	PME5
	2	0000 0010	33	24	PMD5
	3	-	-	-	Disable low
CFGTMR2_CH4	1	0000 0010	25	-	PMD13
	2	0000 0100	6	4	PME10
	3	-	-	-	Disable low
CFGTMR2_CH5	1	0000 0010	24	-	PMD14
	2	0000 0100	5	3	PME11
	3	-	-	-	Disable low
CFGTMR2_CH6	1	0000 0100	2	-	PME15
	2	0000 0011	50	-	PMC12

Function	Priority	PM_PINCTRLx[ MUXCTRL]	Number of 100 Pins	Number of 64 Pins	Pin
	3	-	-	-	Disable low
CFGTMR2_CH7	1	0000 0011	49	-	PMC13
	2	0000 0100	1	-	PME16
	3	-	-	-	Disable low
CFGTMR2_FLT0	1	0000 0100	7	-	PME13
	2	0000 0100	18	13	PME3
	3	-	-	-	Disable low
CFGTMR2_FLT1	1	0000 0100	17	-	PME14
	2	0000 0100	33	24	PMD5
	3	-	-	-	Disable low
CFGTMR2_FLT2	1	0000 0100	32	23	PMD6
	2	0000 0100	42	-	PMD8
	3	-	-	-	Disable low
CFGTMR2_FLT3	1	0000 0100	31	22	PMD7
	2	0000 0100	41	-	PMD9
	3	-	-	-	Disable low
CFGTMR2_QD_PH A	1	0000 0011	8	5	PME5
	2	0000 0101	79	50	PMA0
	3	0000 0011	35	-	PMD11
	4	0000 0110	89	55	PMA13
	5	-	-	-	Disable low
CFGTMR2_QD_PH B	1	0000 0110	95	61	PMC5
	2	0000 0011	36	-	PMD10
	3	0000 0011	9	6	PME4
	4	0000 0110	90	56	PMA12
	5	-	-	-	Disable low
CFGTMR3_CH0	1	0000 0010	77	-	PMB8
	2	0000 0010	73	48	PMA2
	3	-	-	-	Disable low
CFGTMR3_CH1	1	0000 0010	72	47	PMA3
	2	0000 0010	76	-	PMB9
	3	-	-	-	Disable low

Function	Priority	PM_PINCTRLx[ MUXCTRL]	Number of 100 Pins	Number of 64 Pins	Pin
CFGTMR3_CH2	1	0000 0100	81	52	PMC6
	2	0000 0010	75	-	PMB10
	3	-	-	-	Disable low
CFGTMR3_CH3	1	0000 0010	74	-	PMB11
	2	0000 0100	80	51	PMC7
	3	-	-	-	Disable low
CFGTMR3_CH4	1	0000 0010	71	46	PMD2
	2	0000 0010	52	-	PMC10
	3	-	-	-	Disable low
CFGTMR3_CH5	1	0000 0010	51	-	PMC11
	2	0000 0010	70	45	PMD3
	3	-	-	-	Disable low
CFGTMR3_CH6	1	0000 0100	85	54	PME2
	2	0000 0010	50	-	PMC12
	3	-	-	-	Disable low
CFGTMR3_CH7	1	0000 0010	49	-	PMC13
	2	0000 0100	84	53	PME6
	3	-	-	-	Disable low
CFGTMR3_FLT0	1	0000 0011	59	39	PME7
	2	0000 0011	62	-	PMA17
	3	-	-	-	Disable low
CFGTMR3_FLT1	1	0000 0011	67	42	PMB13
	2	0000 0011	88	-	PMA14
	3	-	-	-	Disable low
CFGTMR3_FLT2	1	0000 0011	68	43	PMB12
	2	0000 0101	99	-	PMA9
	3	-	-	-	Disable low
CFGTMR3_FLT3	1	0000 0011	69	44	PMD4
	2	0000 0101	100	-	PMA8
	3	-	-	-	Disable low
CFGTMR4_CH2	1	0000 0011	51	-	PMC11
	2	-	-	-	Disable low

Function	Priority	PM_PINCTRLx[ MUXCTRL]	Number of 100 Pins	Number of 64 Pins	Pin
CFGTMR4_CH5	1	0000 0110	53	33	PMB1
	2	0000 0010	7	-	PME13
	3	-	-	-	Disable low
CFGTMR4_FLT0	1	0000 0101	1	-	PME16
	2	0000 0111	99	-	PMA9
	3	-	-	-	Disable low
CFGTMR4_FLT1	1	0000 0101	2	-	PME15
	2	0000 0110	100	-	PMA8
	3	-	-	-	Disable low
CFGTMR5_CH0	1	0000 0100	55	35	PMC9
	2	-	-	-	Disable low
CFGTMR5_CH1	1	0000 0100	56	36	PMC8
	2	-	-	-	Disable low
CFGTMR5_CH3	1	0000 0011	57	37	PMA7
	2	-	-	-	Disable low
CFGTMR5_CH5	1	0000 0100	58	38	PMA6
	2	-	-	-	Disable low
CFGTMR5_FLT0	1	0000 0100	19	-	PME12
	2	0000 0101	62	-	PMA17
	3	-	-	-	Disable low
CFGTMR5_FLT1	1	0000 0100	20	-	PMD17
	2	0000 0100	63	-	PMB17
	3	-	-	-	Disable low
CFGIO_D0	1	0000 0110	4	2	PMD0
	2	0000 0100	92	58	PMA10
	3	0000 0011	41	-	PMD9
	4	-	-	-	Disable low
CFGIO_D1	1	0000 0110	3	1	PMD1
	2	0000 0100	91	57	PMA11
	3	0000 0101	42	-	PMD8
	4	-	-	-	Disable low
CFGIO_D2	1	0000 0110	2	-	PME15

Function	Priority	PM_PINCTRLx[ MUXCTRL]	Number of 100 Pins	Number of 64 Pins	Pin
	2	0000 0100	79	50	PMA0
	3	-	-	-	Disable low
CFGIO_D3	1	0000 0100	78	49	PMA1
	2	0000 0110	1	-	PME16
	3	-	-	-	Disable low
CFGIO_D4	1	0000 0100	71	46	PMD2
	2	0000 0110	6	4	PME10
	3	0000 0101	73	48	PMA2
	4	-	-	-	Disable low
CFGIO_D5	1	0000 0110	5	3	PME11
	2	0000 0100	70	45	PMD3
	3	0000 0101	72	47	PMA3
	4	-	-	-	Disable low
CFGIO_D6	1	0000 0110	9	6	PME4
	2	0000 0100	100	-	PMA8
	3	0000 0101	71	46	PMD2
	4	-	-	-	Disable low
CFGIO_D7	1	0000 0110	8	5	PME5
	2	0000 0100	99	-	PMA9
	3	0000 0101	70	45	PMD3
	4	-	-	-	Disable low
LPI2C0_HREQ	1	0000 0011	74	-	PMB11
	2	0000 0011	93	59	PME1
	3	-	-	-	Disable low
LPI2C0_SCL	1	0000 0011	72	47	PMA3
	2	0000 0010	15	11	PMB7
	3	-	-	-	Disable low
LPI2C0_SCLS	1	0000 0011	76	-	PMB9
	2	0000 0011	79	50	PMA0
	3	-	-	-	Disable low
LPI2C0_SDA	1	0000 0010	16	12	PMB6
	2	0000 0011	73	48	PMA2

Function	Priority	PM_PINCTRLx[ MUXCTRL]	Number of 100 Pins	Number of 64 Pins	Pin
	3	-	-	-	Disable low
LPI2C0_SDAS	1	0000 0011	78	49	PMA1
	2	0000 0011	75	-	PMB10
	3	-	-	-	Disable low
LPSPi0_PCS0	1	0000 0011	54	34	PMB0
	2	0000 0100	27	18	PMB5
	3	-	-	-	Disable low
LPSPi0_PCS1	1	0000 0011	27	18	PMB5
	2	-	-	-	Disable low
LPSPi0_SCK	1	0000 0011	48	32	PMB2
	2	0000 0010	94	60	PME0
	3	0000 0100	22	15	PMD15
	4	-	-	-	Disable low
LPSPi0_SIN	1	0000 0010	93	59	PME1
	2	0000 0011	47	31	PMB3
	3	0000 0100	21	14	PMD16
	4	-	-	-	Disable low
LPSPi0_SOUT	1	0000 0010	85	54	PME2
	2	0000 0011	28	19	PMB4
	3	0000 0011	53	33	PMB1
	4	-	-	-	Disable low
LPSPi1_PCS0	1	0000 0011	70	45	PMD3
	2	0000 0101	93	59	PME1
	3	-	-	-	Disable low
LPSPi1_PCS1	1	0000 0011	58	38	PMA6
	2	-	-	-	Disable low
LPSPi1_SCK	1	0000 0011	4	2	PMD0
	2	0000 0011	66	-	PMB14
	3	-	-	-	Disable low
LPSPi1_SIN	1	0000 0011	65	-	PMB15
	2	0000 0011	3	1	PMD1
	3	-	-	-	Disable low

Function	Priority	PM_PINCTRLx[ MUXCTRL]	Number of 100 Pins	Number of 64 Pins	Pin
LPSP11_SOUT	1	0000 0011	71	46	PMD2
	2	0000 0011	64	-	PMB16
	3	0000 0101	94	60	PME0
	4	-	-	-	Disable low
LPSP12_PCS0	1	0000 0011	99	-	PMA9
	2	0000 0011	46	30	PMC14
	3	0000 0010	5	3	PME11
	4	-	-	-	Disable low
LPSP12_PCS1	1	0000 0011	6	4	PME10
	2	-	-	-	Disable low
LPSP12_SCK	1	0000 0011	2	-	PME15
	2	0000 0011	45	29	PMC15
	3	-	-	-	Disable low
LPSP12_SIN	1	0000 0011	1	-	PME16
	2	0000 0011	40	26	PMC0
	3	-	-	-	Disable low
LPSP12_SOUT	1	0000 0011	100	-	PMA8
	2	0000 0011	39	25	PMC1
	3	-	-	-	Disable low
LPTMR0_ALT3	1	0000 0011	85	54	PME2
	2	0000 0100	54	34	PMB0
	3	-	-	-	Disable low
LPUART0_CTS	1	0000 0110	56	36	PMC8
	2	0000 0110	79	50	PMA0
	3	-	-	-	Disable low
LPUART0_RX	1	0000 0110	73	48	PMA2
	2	0000 0010	54	34	PMB0
	3	0000 0100	30	21	PMC2
	4	-	-	-	Disable low
LPUART0_TX	1	0000 0110	72	47	PMA3
	2	0000 0010	53	33	PMB1
	3	0000 0100	29	20	PMC3



Function	Priority	PM_PINCTRLx[ MUXCTRL]	Number of 100 Pins	Number of 64 Pins	Pin
	4	-	-	-	Disable low
LPUART1_CTS	1	0000 0110	58	38	PMA6
	2	0000 0110	85	54	PME2
	3	0000 0010	2	-	PME15
	4	-	-	-	Disable low
LPUART1_RX	1	0000 0010	81	52	PMC6
	2	0000 0010	56	36	PMC8
	3	0000 0011	25	-	PMD13
	4	-	-	-	Disable low
LPUART1_TX	1	0000 0010	55	35	PMC9
	2	0000 0010	80	51	PMC7
	3	0000 0011	24	-	PMD14
	4	-	-	-	Disable low
LPUART2_CTS	1	0000 0011	23	16	PME9
	2	0000 0110	35	-	PMD11
	3	0000 0100	50	-	PMC12
	4	-	-	-	Disable low
LPUART2_RX	1	0000 0010	32	23	PMD6
	2	0000 0011	20	-	PMD17
	3	0000 0010	100	-	PMA8
	4	-	-	-	Disable low
LPUART2_TX	1	0000 0010	31	22	PMD7
	2	0000 0011	19	-	PME12
	3	0000 0010	99	-	PMA9
	4	-	-	-	Disable low

## 7 Electrical Characteristics

### 7.1 Test under general operating conditions

#### 7.1.1 Absolute maximum rated value

If the load on the device exceeds the absolute maximum rated value, it may cause permanent damage to the device. Here, only the maximum load that can be borne is given, and it cannot be ensured that the device functions normally under this condition. At the same time, operation shall be performed strictly according to all the conditions defined in the table, and violating any one or more conditions cannot guarantee normal operation of the function.

Unless otherwise specified, all maximum and minimum values can support the full voltage and temperature range.

Table 6 Absolute Maximum Ratings

Symbol	Parameter <sup>(1)</sup>	Minimum value	Typical value	Maximum value	Unit
T <sub>A</sub> <sup>(2)</sup>	Ambient temperature	-40	-	125	°C
T <sub>STG</sub>	Storage temperature range	-55	-	165	
I <sub>INJ</sub> <sup>(3)</sup>	Continuous DC input current(positive/negative) for injection into I/O pins	-3	-	+3	mA
Σ I <sub>INJ</sub>	Total injection current of all pins (continuous DC limit)	-	-	30	
V <sub>DD</sub> <sup>(4)</sup>	2.7V~5.5V input power supply voltage	-0.3	-	5.8 <sup>(5)</sup>	V
V <sub>REFH</sub>	3.3V/5.0V ADC high reference voltage	-0.3	-	5.8 <sup>(5)</sup>	
V <sub>IN</sub>	Continuous DC voltage on any I/O pin relative to V <sub>SS</sub>	-0.8	-	5.8 <sup>(6)</sup>	
V <sub>IN_TRANSIENT</sub>	Transient overshoot voltage allowed on I/O pins exceeds the V <sub>IN</sub> limit	-	-	6.8 <sup>(7)</sup>	
T <sub>ramp_MCU</sub> <sup>(8)</sup>	MCU supply rise slope	0.5V/min	-	100V/ms	-
T <sub>ramp</sub> <sup>(9)</sup>	ECU supply rise slope	0.5V/min	-	500V/ms	-

Notes:

- (1) Unless otherwise specified, all voltages are referred to V<sub>SS</sub> ;
- (2) T<sub>J</sub> (junction temperature)=135°C. Assuming T<sub>A</sub>=125°C in run mode;  
T<sub>J</sub> (junction temperature)=125°C. Assuming T<sub>A</sub>=105°C in high-speed run mode;  
Assuming the maximum of the 2s2p board is θ<sub>JA</sub>. Refer to Temperature Characteristics);
- (3) When the input pad voltage is close to V<sub>DD</sub> or V<sub>SS</sub>, current injection cannot be conducted;

- (4) When  $V_{DD}$  changes between the minimum and absolute maximum values, both I/O and ADC will change. For detailed information, please refer to the I/O parameters and ADC electrical specifications;
- (5) When the lifespan is 60 seconds: unlimited, that is, this part is not held in a reset state and can be switched;  
 When the service life is 10 hours: this part is held in the reset state through external circuits, and cannot be switched;  
 When operating with a power supply between 5.5V and 5.8V not in reset state, a total of 60 seconds is allowed, but this part will run with reduced function;  
 When operating with a power supply between 5.5V and 5.8V while the system is held in the reset state through external circuit, a total of 10 hours is allowed;  
 All power supplies shall be always maintained within the given working conditions, and once they deviate from the working conditions, the equipment shall be reset or powered off. If the given time or power supply voltage limit is exceeded, permanent damage might be caused to the equipment;
- (6) Obey the maximum current injection limit.
- (7) Under the condition of 60-second lifespan; the equipment is in a reset state (no output enabled/switched);
- (8) The supply rise slope of the electronic control unit (ECU) under typical operating conditions and absolute maximum slope;
- (9) The supply rise slope of MCU under typical operating conditions and absolute maximum slope.

### 7.1.2 Voltage and current operation requirements

The functionality of the equipment is guaranteed above the LVR level, but when the voltage is below 2.7V, the electrical performance of the ADC, COMP, IO, and communication modules will correspondingly decrease.

Table 7 Electrical Characteristics of Voltage and Current <sup>(1)</sup>

Symbol	Parameter	Minimum value	Typical value	Maximum value	Unit
$V_{DD}^{(2)(3)}$	Supply voltage	2.7 <sup>(4)</sup>	-	5.5	V
$V_{DDA}^{(3)}$	Analog power supply voltage	2.7	-	5.5	
$V_{DD} - V_{DDA}^{(3)}$	$V_{DD} - V_{DDA}$ voltage difference	-0.1	-	0.1	
$V_{ODPU}^{(5)}$	Open-drain pull-up voltage	$V_{DD}$	-	$V_{DD}$	
$V_{DD(OFF)}$	The voltage allowed to be generated on the VDD pin when the VDD is not powered by any external power supply	0	-	0.1	
$I_{INJ}^{(6)}$	Injection current of I/O pin (continuous DC)	-3	-	+3	mA
$\Sigma I_{INJ\_OP}$	The total injection current (continuous DC) of all I/O pins, in order not to reduce the accuracy of the analog module: ADC and ACOMP (refer to the "Analog Module" section)	-	-	30	

Symbol	Parameter	Minimum value	Typical value	Maximum value	Unit
$V_{REFINTL}$	Low level of ADC built-in reference voltage	-0.1	-	0.1	V
$V_{REFINTH}^{(7)}$	High level of ADC built-in reference voltage	2.7	-	$V_{DDA}+0.1$	

Notes:

- (1) Unless otherwise specified, the data in the table is tested with the typical silicon process under the conditions of  $T_A=25^{\circ}\text{C}$  and  $V_{DD}=V_{DDA}=V_{REFH}=5\text{V}$ .
- (2) The analog characteristics of I/O and ADC will change with the change of  $V_{DD}$  between the minimum and maximum values.
- (3)  $V_{DD}$  and  $V_{DDA}$  must be shorted to the common power supply on the PCB. The differential voltage between  $V_{DD}$  and  $V_{DDA}$  is only used for RF-AC. Select a suitable decoupling capacitor to filter the noise on the power supply.
- (4) When executing from internal HSICLK, it will work at 2.7V in all modes
- (5) The open-drain output must be pulled to  $V_{DD}$ .
- (6) When the input pad voltage is close to  $V_{DD}$  or  $V_{SS}$ , current injection cannot be conducted.
- (7)  $V_{REFINTH}$  should always be  $\leq V_{DDA}+0.1\text{ V}$  and  $V_{DD}+0.1\text{ V}$ .

### 7.1.3 Temperature operation characteristics

Table 8 Temperature Operation Characteristics

Symbol	Parameter	Condition	Minimum value	Typical value	Maximum value	Unit
$T_{A(MGP)}$	Ambient temperature under bias conditions	$\leq 80\text{ MHz, RUN mode}$	-40	-	125	°C
$T_{J(MGP)}$	Junction temperature under bias conditions	$\leq 80\text{ MHz, RUN mode}$	-40	-	135	
$T_{A(CGP)}$	Ambient temperature under bias conditions	$\leq 112\text{ MHz, HSR mode}$	-40	-	85	
$T_{J(CGP)}$	Junction temperature under bias conditions	$\leq 112\text{ MHz, HSR mode}$	-40	-	105	
$T_{A(VGP)}$	Ambient temperature under bias conditions	$\leq 112\text{ MHz, HSR mode}$	-40	-	105	
$T_{J(VGP)}$	Junction temperature under bias conditions	$\leq 112\text{ MHz, HSR mode}$	-40	-	125	

### 7.1.4 Power supply and ground pins

Figure 4 LQFP64 Encapsulation Outgoing Line Separate Decoupling

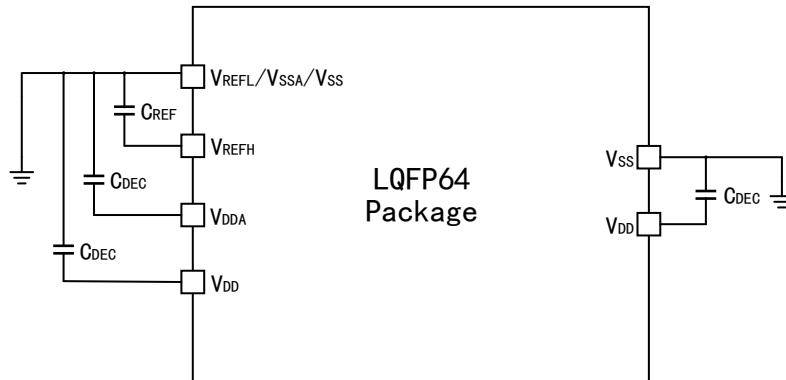
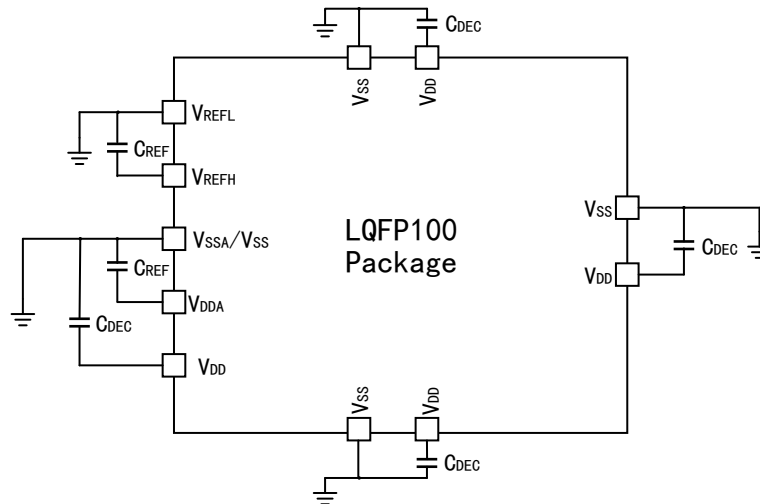

Figure 5 LQFP100 Encapsulation Outgoing Line Separate Decoupling



Note:  $V_{DD}$  and  $V_{DDA}$  must be shorted to the common power supply on the PCB.

Table 9 Decoupling capacitor (1) (2)

Symbol	Parameter	Minimum value <sup>(3)</sup>	Typical value	Maximum value	Unit
$C_{DEC}^{(4) (6) (7)}$	Decoupling capacitance	70	100	-	nF
$C_{REFINT}^{(4) (5)}$	ADC built-in reference high decoupling capacitance	70	100	-	

Notes:

- (1)  $V_{DD}$  and  $V_{DDA}$  must be shorted to the common power supply on the PCB. The differential voltage between  $V_{DD}$  and  $V_{DDA}$  is only used for RF-AC. Select a suitable decoupling capacitor to filter the noise on the power supply.
- (2) All  $V_{SS}$  pins should be connected to a PCB-level common ground.
- (3) Low-ESR ceramic capacitor (e.g. X7R type) shall be selected as decoupling capacitor.
- (4) Recommended minimum value while considering the component aging and tolerance.
- (5) All decoupling capacitors shall be as close as possible to the corresponding power supply and ground pin.

- (6) To improve the performance, it is recommended to use 0.1µF, 10µF and 1 nF capacitors in parallel.
- (7) The filtering of decoupling device power supply must comply with the following best practice rules:
- The grounding of the protective device and the grounding plane under the integrated circuit shall be connected as short as possible.
  - The length of the trace from the protective device to the trace or to the ground shall not exceed 1 mm.
  - The protective/decoupling capacitor must be located on the trace path connected to the component.
  - The protective/decoupling capacitor must be as close to the input pin of the equipment as possible (at most 2 mm).

Figure 6 Power Supply Scheme

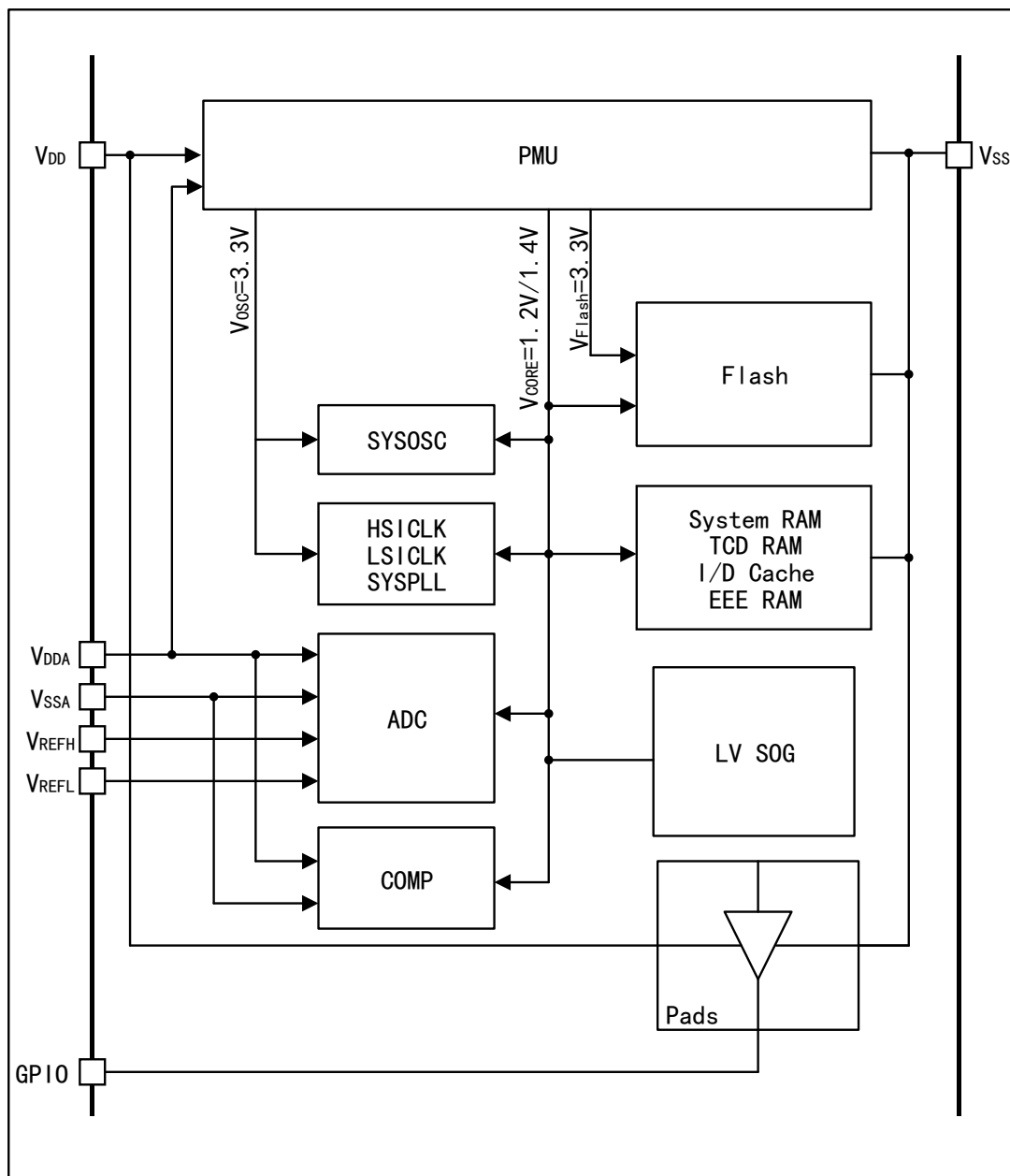

## 7.1.5 Low-voltage reset and detection system characteristics

Table 10 POR Characteristics

Symbol	Parameter	Minimum value	Typical value	Maximum value	Unit
$V_{POR}$	$V_{DD}$ power-on reset rising and falling detection voltage	1.1	1.6	2.0	V
$V_{BG}$	Band-gap voltage reference	0.97	1.00	1.03	

Table 11 LVR Characteristics

Symbol	Parameter	Minimum value	Typical value	Maximum value	Unit
$V_{LVR}$	Low-voltage reset falling threshold (RUN, HSR, STOP mode)	2.50	2.58	2.7	V
	Low-voltage reset falling threshold (VLPS/VLPR mode)	1.97	2.22	2.44	
$V_{LVR(HYST)}^{(1)}$	Low-voltage reset hysteresis (When power-on-voltage is higher than $V_{POR}$ )	-	45	-	mV
	Low-voltage reset hysteresis (When power-on-voltage is lower than $V_{POR}$ )	-	110	-	

Note: (1) The rising threshold is the sum of falling threshold and hysteresis voltage.

Table 12 LVD Characteristics

Symbol	Parameter	Minimum value	Typical value	Maximum value	Unit
$V_{LVD}$	Low-voltage detection falling threshold	2.8	2.875	3	V
$V_{LVD(HYST)}^{(1)}$	Low-voltage detection hysteresis	-	60	-	mV

Note: (1) The rising threshold is the sum of falling threshold and hysteresis voltage.

Table 13 LVW Characteristics <sup>(1)</sup>

Symbol	Parameter	Minimum value	Typical value	Maximum value	Unit
$V_{LVW}$	Low-voltage alarm falling threshold	4.19	4.305	4.5	V
$V_{LVW(HYST)}^{(2)}$	Low-voltage alarm hysteresis	-	75	-	mV

Notes:

- (1) When the power supply is working within 3.3 V, as the power supply is less than  $V_{LVW}$  all along, it is necessary to always set  $V_{LVW}$  (i.e. PMU\_LVDCSTS2 [LVWHWINTREN] should remain clear state).
- (2) The rising threshold is the sum of falling threshold and hysteresis voltage.

## 7.1.6 Power mode conversion characteristics

All specifications in the table below use this clock configuration

Table 14 Clock Configuration

Mode	Clock configuration	
RUN mode	Clock Source	HSICLK
	SYS_CLK/CORE_CLK	48MHz
	BUS_CLK	48MHz
	FLASH_CLK	24MHz
HSR mode	Clock Source	SYSPLL
	SYS_CLK/CORE_CLK	112MHz
	BUS_CLK	56MHz
	FLASH_CLK	28MHz
VLPR mode	Clock Source	LSICLK
	SYS_CLK/CORE_CLK	4MHz
	BUS_CLK	4MHz
	FLASH_CLK	1MHz
STOP1/STOP2 mode	Clock Source	HSICLK
	SYS_CLK/CORE_CLK	48MHz
	BUS_CLK	48MHz
	FLASH_CLK	24MHz
VLPS mode	Disable all clock sources <sup>(1)</sup>	

Note: (1) It refers to HSICLK/SYSOSC/SYSPLL

Table 15 Power Mode Conversion Operation Behavior

Symbol	Parameter	Minimum value	Typical value	Maximum value	Unit
t <sub>POR</sub>	The time required to execute the first command from V <sub>DD</sub> to 2.7V within the operating temperature range of the chip after the power-on reset event occurs.	-	325	-	μs
	RUN→STOP1	0.35	0.38	0.4	μs
	RUN→STOP2	0.2	0.23	0.25	μs
	RUN→VLPS	0.3	0.35	0.4	μs
	RUN→VLPR	3.5	3.8	5	μs
	RUN→Compute operation	0.72	0.75	0.77	μs
	HSR <sup>(1)</sup> →Compute operation	0.3	0.31	0.35	μs
	VLPS→RUN	8	-	17	μs
	VLPS→VLPR	18.8	23	27.75	μs



Symbol	Parameter	Minimum value	Typical value	Maximum value	Unit
	VLPS→Asynchronous DMA Wake-up	105	110	125	μs
	VLPR→VLPS	5.1	5.7	6.5	μs
	VLPR→RUN	19	-	26	μs
	STOP1→RUN	0.07	0.075	0.08	μs
	STOP2→RUN	0.07	0.075	0.08	μs
	STOP1→Asynchronous DMA Wake-up	1	1.1	1.3	μs
	STOP2→Asynchronous DMA Wake-up	1	1.1	1.3	μs
	Pin reset→Code execution	-	214	-	μs

Note: (1) HSR mode shall only be used when it is necessary to use frequency exceeding 80 MHz. When using a frequency of 80 MHz and below, it is recommended to use the RUN mode.

### 7.1.7 Power Consumption

Table 16 Power Consumption <sup>(1)</sup>

Working mode	Condition	Typical value				Maximum value			Unit
		25°C	85°C	105°C	125°C	85°C	105°C	125°C	
VLPS <sup>2)</sup>	Disable peripherals ( <sup>3)</sup> )	56	330	674	-	974	2004	3358	μA
	Enable LPTMR	62	330	680	-	981	2017	3380	
VLPR	Disable peripherals ( <sup>4)</sup> )	1.57	1.79	1.99	-	3.32	4.06	5.28	mA
	Enable peripherals, (situation 1) ( <sup>4)</sup> )	1.61	1.83	2.04	-	3.38	4.13	5.38	mA
	Enable peripherals, (situation 2) ( <sup>5)</sup> )	3.3	3.54	3.78	4.44	-	-	-	mA
STOP1	-	8	8.9	9.8	-	12.7	17.1	22.6	mA
STOP2	-	9.2	10.1	11	-	13.9	18.3	23.7	mA
RUN	48MHz, disable peripherals	23.4	24.4	25.3	-	29.3	34.1	40.2	mA

Working mode	Condition	Typical value				Maximum value			Unit
		25°C	85°C	105°C	125°C	85°C	105°C	125°C	
	48MHz, enable peripherals	31.4	32.4	33.4	-	37.9	42.6	48.8	mA
	64MHz, disable peripherals	30.5	31.5	32.5	-	36.7	41.3	47.3	mA
	64MHz, enable peripherals	40.2	41.3	42.2	-	47	51.4	57.4	mA
	80MHz, disable peripherals	36.2	37.2	38.1	-	42.4	46.9	52.8	mA
	80MHz, enable peripherals	47.6	48.7	49.6	-	54.4	58.8	64.8	mA
	HSR <sup>(6)</sup>	112MHz, disable peripherals	52	53.3	54.4	-	60.3	65.7	-
112MHz, enable peripherals		68.3	69.8	70.8	-	78	82.8	-	mA
IDDA/MHz <sup>(7)</sup>		452	465	577	-	530	587	660	( $\mu$ A/MHz)

Notes:

- (1) Unless otherwise specified, the data in the table is tested with the typical silicon process under the conditions of  $T_A=25^\circ\text{C}$  and  $V_{DD}=V_{DDA}=V_{REFINTH}=5\text{V}$ . These values are only used as indexes of typical silicon processes and user configurations. The actual values may vary due to the differences in silicon distribution and user configuration. All output pins are suspended and the on-chip pull-down resistor is enabled for all unused input pins.
- (2) The current data is data based on simplified configuration, which may vary due to the differences in silicon distribution and user configuration.
- (3) When PMU\_REGCSTS [CLKBDIS] is set to 1. Please refer to the *User Manual* for details.
- (4) Data collected by RAM
- (5) Limited sample size and data collected by Flash
- (6) The maximum ambient temperature for HSR mode is  $105^\circ\text{C}$ , and HSR mode shall not be used at  $125^\circ\text{C}$ .
- (7) The above values are obtained during testing in RUN mode at 80 MHz with the peripheral disabled.

Table 17 Power Consumption of VLPS Additional Cases <sup>(1)</sup> <sup>(2)</sup> <sup>(3)</sup>

Cases	Condition	Typical value (3)				Unit
		25°C	85°C	105°C	125°C	
VLPS and RTC	Clock source: LPO or RTC_CLKIN	57	340	687	1441	μA
VLPS and LPUART wake-up	Clock source: LSICLK Enable address wake-up function Baud rate: 19.2 kbps	160	336	576	1200	
VLPS and LPUART TX/RX	Clock source: LSICLK Use DMA to transmit or receive data Baud rate: 19.2 kbps	250	524	880	1617	
VLPS and LPSPI master mode <sup>(4)</sup>	Clock source: LSICLK Use DMA to transmit or receive data Baud rate: 500 kHz	3.75	4.35	4.93	5.97	mA
VLPS and LPI2C master mode	Clock source: LSICLK Use DMA to transmit or receive data Baud rate: 100 kHz	1093	1524	2013	2882	μA
VLPS and LPI2C slave mode wake-up	Clock source: LSICLK Enable address wake-up function Baud rate: 100 kHz	324	492	732	1405	
VLPS and LPITMR	Clock source: LSICLK Enable one Channel Mode: 32-bit cycle counter	167	442	780	1505	

Notes:

- (1) The current data is tested under specific application code and may change due to the changes in user configuration and silicon process.
- (2) The power data includes the power caused by periodic wake-up and the operating power of VLPS mode, which will make the power data more dependent on the application code
- (3) The typical values are tested based on  $V_{DD}=V_{DDA}=V_{REFH}=5V$ ,  $T_A=25^{\circ}C$ , and typical silicon process.
- (4) The single LPSPI used in G32A1465 refers to LPSP11.

### 7.1.8 ESD and Latch-up protection characteristics

Table 18 ESD Electrostatic Discharge Characteristics

Symbol	Parameter	Minimum value	Maximum value	Unit
$V_{ESD(HBM)}$	Electrostatic discharge voltage (human body model) <sup>(1)</sup> <sup>(2)</sup> <sup>(3)</sup>	-4000	4000	V

Symbol	Parameter	Minimum value	Maximum value	Unit
$V_{ESD(CDM)}$	Electrostatic discharge voltage (charging device model) <sup>(1)</sup> <sup>(2)</sup> <sup>(4)</sup>			
	All pins except corner pins	-500	500	V
	Corner pin	-750	750	V

Note: (1) Equipment fault is defined as: "Once the equipment is exposed to ESD pulses, the equipment will not meet the specification requirements."

Table 19 Latch-up Static Latch Characteristics

Symbol	Description	Minimum value	Maximum value	Unit
LU	Latch-up current at $T_A=125^{\circ}\text{C}$	-100	100	mA

### 7.1.9 EMC radiated emission characteristics (to be tested)

Geehy can provide EMC measurements that meet IC-level IEC standards as required.

## 7.2 Memory and interface

### 7.2.1 Time characteristics of Flash command

The following parameters are tested at a clock frequency of FLASHCLK not less than 25MHz.

Table 20 Reading Time Characteristics

Symbol	Parameter	Condition	Minimum value	Typical value	Maximum value	Unit
$t_{VB}$	Verifying FLASH block is blank time	32KB Flash	-	-	-	ms
		64KB Flash	-	0.5	2	
		128KB Flash	-	-	-	
		256KB Flash	-	-	-	
		512KB Flash	-	2	8	
$t_{VA}$	Verifying FLASH section is blank time	2KB Flash	-	-	75	$\mu\text{s}$
		8KB Flash	-	-	100	
$t_{VAB}$	Verifying all FLASH blocks are blank time	-	-	5.2	17.4	ms
$t_{RO}$	Read once time	-	-	-	30	$\mu\text{s}$

Table 21 Programming Time Characteristics

Symbol	Parameter	Condition	Minimum value	Typical value	Maximum value	Unit
t <sub>PGCK</sub>	Programming check time	-		-	95	μs
T <sub>PGDU</sub>	Programming data unit time	-		-	225	μs
t <sub>PGDA</sub>	Programming data area time	1KB Flash		5	-	ms
t <sub>PO</sub>	Program once Time	-		123	-	μs
t <sub>VBAK</sub>	Verifying backdoor access key time	-		-	35	μs
t <sub>PGEP</sub>	Programming EEPROM partition time	32KB EEPROM (backup)		70	-	ms
		64KB EEPROM (backup)		71	-	
t <sub>SFRF</sub>	Set CFGRAM function time	Control code 0xFF		0.08	-	ms
		32KB EEPROM (backup)		0.8	1.2	
		48KB EEPROM (backup)		1	1.5	
		64KB EEPROM (backup)	-	1.3	1.9	
t <sub>WFRB</sub>	Write CFGRAM in byte time	32KB EEPROM (backup)	-	385	1700	μs
		48KB EEPROM (backup)	-	430	1850	
		64KB EEPROM (backup)	-	475	2000	
t <sub>WFRHW</sub> <sup>(1)</sup>	Write CFGRAM in half-word time	32KB EEPROM (backup)	-	385	1700	μs
		48KB EEPROM (backup)	-	430	1850	
		64KB EEPROM (backup)	-	475	2000	
t <sub>WFRW</sub> <sup>(1)</sup>	Write CFGRAM in word time	32KB EEPROM (backup)	-	630	2000	μs
		48KB EEPROM (backup)	-	720	2125	
		64KB EEPROM (backup)	-	810	2250	
t <sub>WEFRW</sub> <sup>(1)</sup>	Write erased CFGRAM in word time	-	-	360	2000	μs

Symbol	Parameter	Condition	Minimum value	Typical value	Maximum value	Unit
$t_{qww}^{(1)(2)(3)}$	Quickly write in word time	First write	-	200	550	$\mu s$
		From the second write to the last but one write	-	150	550	
		The last write	-	200	550	
$t_{qwc}^{(4)}$	Quickly write cleanup execution time	-	-	-	$2 \cdot t_{qww}$	ms

Note:

(1) If the actually displayed time is twice the theoretical value, it may be because after CFGRAM is reset or set, EERAM is written for the first time, causing addition time to clear EEE.

(2) Emulation EEPROM records may be cleared after power down, reset, or completion of a write. If a power-up reset occurs before completion of a write, the last record will be retained and the new record will be cleared. So the data will only be valid after the final write is completed.

(3) The actual maximum value may not be limited to 550us, because additional clearing time may be caused when performing cross-sector operations.

(4) The time required to simulate EEPROM recording. After the last (Nth) write operation is completed, it will automatically complete, assuming it is still powered on at this time. Alternatively, the command can be cleared through SETRAM and executed in the future.

Table 22 Erasing Time Characteristics

Symbol	Parameter	Condition	Minimum value	Typical value	Maximum value	Unit
$t_{EB}$	Erase FLASH block time	32KB Flash	-	-	-	ms
		64KB Flash	-	24	550	
		128KB Flash	-	-	-	
		256KB Flash	-	-	-	
		512KB Flash	-	30	4250	
$t_{ES}$	Erase FLASH sector time	-	-	1	130	ms
$t_{EAB}$	Erase all blocks time	-	-	83	10000	ms
$t_{UEAB}$	unsecure erase of all blocks time	-	-	83	10000	ms

Note: (1) Maximum times to erase parameters is based on the expected end of cycle life.

Table 23 Life Time of MTP

Symbol	Parameter	Condition	Minimum value	Typical value	Maximum value	Unit
t <sub>RET</sub>	Data saving time	T <sub>A</sub> = 125°C	10.77	-	-	years
N <sub>RW</sub>	Erase cycle	T <sub>A</sub> = 125°C	100K	-	-	cycles

## 7.2.2 Reliability specifications

Table 24 NVM reliability specifications

Symbol	Parameter	Condition		Minimum value	Typical value	Maximum value	Unit
t <sub>WE16</sub> <sup>(1,2)</sup>	Write endurance	EEPROM backup to CFGRAM	Use as PFlash or DFlash	100K	-	-	writes
t <sub>WE256</sub> <sup>(1)</sup>	Write endurance	ratio=16		TBD	-	-	writes
t <sub>DR100</sub>	Data retention	EEPROM backup to CFGRAM		TBD	-	-	years
t <sub>DR10</sub>	Data retention	ratio=256		TBD	-	-	years
t <sub>DR100KC</sub> <sup>(3)</sup>	Data retention	Up to 100% write endurance		10	-	-	years
t <sub>CE</sub> <sup>(4,5)</sup>	Cycling endurance	Up to 100% write endurance		10K	-	-	cycles
		After up to 100K cycles	emulated EEPROM				

Note:

(1) Supported within the full temperature range. Write endurance is specifically used for 32-bit writing to CFGRAM. The larger the ratio, the better the write endurance.

(2) Please refer to the parameters of DFlash for the endurance specifications of emulated EEPROM, except for CFGMemory.

(3) The data retention period per block begins upon the initial user factory programming or after each subsequent erase.

(4) Support programming and erasing of PFlash and DFlash within the full temperature range.

(5) It is per PFlash or DFlash Sector.

## 7.3 Clock

### 7.3.1 Characteristics of external clock source

When  $G_m > 5 * G_{m\_crit}$ , the crystal oscillator will stabilize the output clock frequency.

$$G_{m\_crit} = 4 * (ESR + R_s) * (2\pi f_{osc})^2 * (C_0 + C_L)^2$$

$$C_L = C_s + [C_{EXTAL} * C_{XTAL} / (C_{EXTAL} + C_{XTAL})]$$

- (1) ESR: Equivalent series resistance of external crystal
- (2)  $R_s$ : A series resistor connecting XTAL pins and external crystals, used to limit current. Users choose appropriate resistance values based on their actual needs to ensure that the oscillation amplitude is appropriate.
- (3)  $f_{osc}$ : Frequency of external crystal oscillator
- (4)  $C_0$ : Shunt capacitance of external crystal oscillator
- (5)  $C_L$ : Total load capacitance of external crystal oscillator
- (6)  $C_s$ : Stray or parasitic capacitance on pins caused by any PCB trace

The following diagram shows the circuit diagram of the oscillator connection.

Figure 7 Oscillator connection circuit diagram

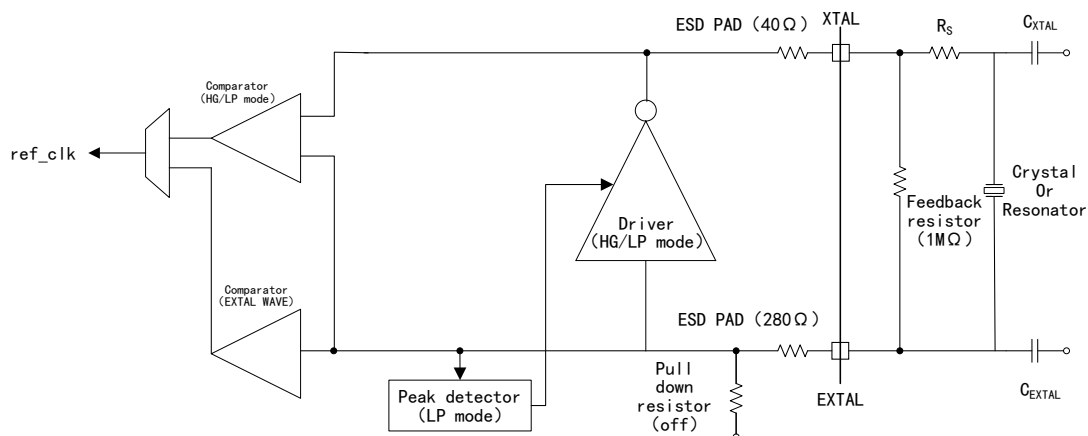

The EXTAL and XTAL pins can only be connected to the oscillator components required by the user.

The difference between Low gain mode and High gain mode is that when selecting Low gain mode, internal RF is selected and external RF should not be attached; When selecting the High gain mode, an external resistance of approximately 1M  $\Omega$  should be used (as shown in the circuit diagram) to ensure the normal operation of the crystal, and the resistance value of the external resistance is allowed to fluctuate by 5%.



Table 25 External Clock Source Characteristics

Symbol	Parameter	Condition	Minimum value	Typical value	Maximum value	Unit
$f_{OSC}$	Oscillator frequency	-	4	-	40	MHz
$f_{in}$	Input frequency (1)	External clock mode	-	-	50	MHz
$f_{in\_dc}$	Input duty cycle (2)	External clock mode	48	50	52	%
$R_F$	Feedback resistance	Low-gain mode	-	-	-	MΩ
		High-gain mode	-	1	-	
$R_S$	Series resistance	Low-gain mode	-	-	-	MΩ
		High-gain mode	-	0	-	
$t_{SU(SYSOSC)}$ (c)	Start Time	8MHz Low-gain mode	-	1.5	-	ms
		8MHz High-gain mode	-	2.5	-	
		40MHz Low-gain mode	-	2	-	ms
		40MHz High-gain mode	-	2	-	
$G_m$	Transconductance of oscillator	SCG_SYSOSCCFG[OSCFSEL]="10", namely 4-8MHz	2.2	-	13.7	mA/V
		SCG_SYSOSCCFG[OSCFSEL]="11", namely 8-40MHz	16	-	47	mA/V
$V_{IL}$	input low level	EXTAL pin in external clock mode	$V_{SS}$	-	1.15	V
$V_{IH}$	Input high level	EXTAL pin in external clock mode	$0.7 \cdot V_{DD}$	-	$V_{DD}$	V
$C_{EXTAL}$	EXTAL pin load capacitance	-	-	-	-	-
$C_{XTAL}$	XTAL pin load capacitance	-	-	-	-	-
$V_{PP\_EXTAL}$	Peak-to-peak amplitude of oscillation on EXTAL pin	Low-gain mode	0.8	-	-	V
		High-gain mode	1.7	-	-	V
$V_{PP\_XTAL}$	Peak-to-peak amplitude of oscillation on XTAL pin	Low-gain mode	-	1.0	-	V
		High-gain mode	-	3.3	-	V
$V_{SYSOSCO\_P}$	Oscillating operating voltage	High-gain mode	1.15	-	-	V

Note:

(1) Frequencies below 40MHz can be used to reduce the duty cycle to 40%~60%. When the frequency is 41MHz~45MHz, a duty cycle of over 40% shall be maintained. When the frequency is 45MHz~50MHz, it is necessary to generate an ADC clock through frequency division.

(2) The duty cycle may have an error of  $\pm 5\%$ .

(3) In the actual testing process, in order to avoid the test value of  $V_{pp\_EXTAL}$  being lower than the actual value, a low capacitance (<5 pF) probe must be used.

### 7.3.2 Electrical characteristics of system clock generator

#### 7.3.2.1 HSI electrical characteristics

Table 26 HSI Electrical Characteristics

Symbol	Parameter	Condition	Minimum value	Typical value	Maximum value	Unit
$f_{HSI}$	HSI frequency	-	-	48	-	MHz
$\Delta f_{105}$	Frequency Error	Temperature < 105°C	-	0.5	$\pm 2$	% $f_{HSI}$
$\Delta f_{125}$	Frequency Error	Temperature < 125°C	-	0.5	$\pm 2.5$	% $f_{HSI}$
$t_{SU(HSI)}$	Start Time	-	-	4	5	$\mu s$
$T_{ctcj}$	Cyclic jitter	HSICLK is used as system clock	-	300	500	ps
$T_{1000cj}$	Over 1000 cycles of jitter	HSICLK is used as system clock	-	0.05	0.1	% $f_{HSI}$

Note:

(1) CPK\_HP is the CPK in high-performance configuration.

(2) At 25°C,  $\Delta f$  is within 1.5%, center value=48.16MHz, CPK\_HP=1.17

(3) At 125°C,  $\Delta f$  is within 3.3%, center value=47.6MHz, CPK\_HP=2.25

(4) At -40°C,  $\Delta f$  is within 1.5%, center value=48.4MHz, CPK\_HP=0.65

#### 7.3.2.2 LSI electrical characteristics

Table 27 LSI Electrical Characteristics

Symbol	Parameter	Condition	Minimum value	Typical value	Maximum value	Unit
$f_{LSI}$	LSI frequency	-	-	8	-	MHz
$\Delta f_{105}$	Frequency Error	Temperature < 105°C	-	-	$\pm 7$	% $f_{LSI}$
$\Delta f_{125}$	Frequency Error	Temperature < 125°C	-	-	$\pm 10$	% $f_{LSI}$
$t_{SU(LSI)}$	Start Time	-	-	15	20	$\mu s$

Note:

- (1) CPK\_HP is the CPK in high-performance configuration; CPK\_LP is the CPK in low-power configuration
- (2) At 25°C,  $\Delta f$  is within 1.5%, center value=8MHz, CPK\_HP=18.19
- (3) At 25°C,  $\Delta f$  is within 1.5%, center value=7.99MHz, CPK\_HP=15.71
- (4) At 125°C,  $\Delta f$  is within 3.25%, center value=8.06MHz, CPK\_HP=1.7
- (5) At 125°C,  $\Delta f$  is within 3.25%, center value=8.13MHz, CPK\_HP=0.96
- (6) At -40°C,  $\Delta f$  is within 6.5%, center value=7.79MHz, CPK\_HP=2.02
- (7) At -40°C,  $\Delta f$  is within 6.5%, center value=7.67MHz, CPK\_HP=0.99

### 7.3.3 Electrical characteristics of low-power oscillators

Table 28 LPO Electrical Characteristics

Symbol	Parameter	Condition	Minimum value	Typical value	Maximum value	Unit
f <sub>LPO</sub>	LPO frequency	-	110	128	140	KHz
t <sub>SU(LPO)</sub>	Start Time	-	-	-	20	μs

### 7.3.4 Electrical characteristics of system PLL

Table 29 Electrical Characteristics of SYSPLL

Symbol	Parameter	Condition	Minimum value	Typical value	Maximum value	Unit
f <sub>SYSPLL</sub>	SYSPLL frequency range	-	8	-	16	MHz
f <sub>SYSPLL_IN</sub>	SYSPLL input frequency	-	8	-	40	MHz
f <sub>SYSPLL_OUT</sub>	SYSPLL output frequency	-	90	-	160	MHz
f <sub>VCO_OUT</sub>	VCO output frequency	-	180	-	320	MHz
T <sub>pj</sub>	Period jitter	f <sub>VCO_OUT</sub> =180MHz	-	120	-	ps
		f <sub>VCO_OUT</sub> =320MHz	-	75	-	ps
T <sub>aj</sub>	Over 1μs accumulated jitter	f <sub>VCO_OUT</sub> =180MHz	-	-	1350	ps
		f <sub>VCO_OUT</sub> =320MHz	-	-	600	ps
t <sub>LDD</sub>	Lock detection time	-	-	-	$150 \times 10^{-6} + 1075(1/f_{SYSPLL})$	s

## 7.4 Clock frequency

The maximum clock output frequency supported by this equipment is 20MHz.

## 7.5 Pin characteristics

### 7.5.1 AC electrical characteristics

Figure 8 I/O AC Characteristics Definition

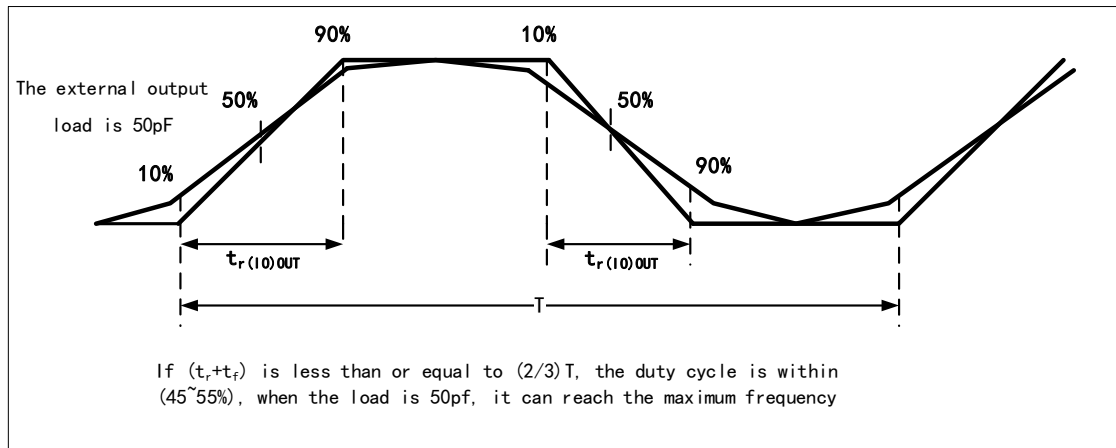

### 7.5.2 General AC specifications

These general specifications apply to all signals configured as GPIO, UART, and timers.

Table 30 General Specifications

Symbol	Parameter	Condition	Minimum value	Typical value	Maximum value	Unit
FRST <sup>(1)</sup>	Reset input filter pulse	-	-	-	10	ns
NFRST <sup>(2)</sup>	Reset input unfiltered pulse	-	Max of(100ns,bus clock period)	-	-	ns
_ <sup>(3)(4)</sup>	GPIO pin interrupt pulse width (disable digital fault filter) - synchronous path	-	1.5	-	-	Bus clock cycle
_ <sup>(5)</sup>	GPIO pin interrupt pulse width (disable digital fault filter, and disable passive filter) - asynchronous path	-	50	-	-	ns

Note:

(1) The maximum length of the RESET pulse that can be filtered by the internal filter only when the passive filter is enabled.

(2) The minimum length of the RESET pulse that can be filtered by the internal filter only when the passive filter is enabled. This number also depends on the bus clock cycle. Then the minimum pulse width that causes reset is 250ns. For faster clock frequencies with clock cycles less than 100ns, the unfiltered minimum pulse width will be 100ns.

(3) The minimum pulse width that ensures passing through the pin synchronous circuit. Short pulse can be recognized when bypassing the synchronizer in stop and VLPS modes, but cannot be recognized in other situations.

(4) The larger values of synchronous and asynchronous timing must be met.

(5) No passive filter is provided at the input end of these pins to ensure the shortest pulse width recognized.

### 7.5.3 Characteristics of IO port

Table 31 DC Characteristics at 3.3V( $T_A=-40^{\circ}\text{C}-105^{\circ}\text{C}$ ,  $V_{DD}=3.3\text{V}$ )

Symbol	Parameter	Minimum value	Typical value	Maximum value	Unit
$V_{DD}$	IO power supply voltage	2.7	3.3	4	V
$V_{IL}$	Low-level input voltage	$V_{SS}-0.3$	-	$0.3 \times V_{DD}$	V
$V_{IH}$	High-level input voltage	$0.7 \times V_{DD}$	-	$V_{DD}+0.3$	V
$V_{hys}$	Input buffer hysteresis	$0.06 \times V_{DD}$	-	-	mV
$I_{ol0}$	I/O current absorption capacity measured when $V_{ol}=0.8\text{ V}$	3	-	-	mA
$I_{oh0}$	I/O current source capacity measured when $V_{oh}=V_{DD}-0.8\text{V}$	3.5	-	-	
$I_{ol1}$	I/O current absorption capacity measured when $V_{ol}=0.8\text{ V}$	12	-	-	
$I_{oh1}$	I/O current source capacity measured when $V_{oh}=V_{DD}-0.8\text{V}$	14	-	-	
IOHT	All ports output high current sum	-	-	100	
$R_{PU}$	Weak pull-up equivalent resistance	20	-	60	k $\Omega$
$R_{PD}$	Weak pull-down equivalent resistance	20	-	60	k $\Omega$

Table 32 DC Characteristics at 5V ( $T_A=-40^{\circ}\text{C}-105^{\circ}\text{C}$ ,  $V_{DD}=5\text{V}$ )

Symbol	Parameter	Minimum value	Typical value	Maximum value	Unit
$V_{DD}$	IO power supply voltage	2.7	4	5.5	V
$V_{IL}$	Low-level input voltage	$V_{SS}-0.3$	-	$0.35 \times V_{DD}$	V
$V_{IH}$	High-level input voltage	$0.65 \times V_{DD}$	-	$V_{DD}+0.3$	V
$V_{hys}$	Input buffer hysteresis	$0.06 \times V_{DD}$	-	-	mV
$I_{ol0}$	I/O current absorption capacity measured when $V_{ol}=0.8\text{ V}$	5	-	-	mA
$I_{oh0}$	I/O current source capacity measured when $V_{oh}=V_{DD}-0.8\text{V}$	5	-	-	
$I_{ol1}$	I/O current absorption capacity measured when $V_{ol}=0.8\text{ V}$	20	-	-	

Symbol	Parameter	Minimum value	Typical value	Maximum value	Unit
Ioh1	I/O current source capacity measured when $V_{oh}=V_{DD}-0.8V$	20	-	-	
IOHT	All ports output high current sum	-	-	100	
R <sub>PU</sub>	Weak pull-up equivalent resistance	20	-	50	k $\Omega$
R <sub>PD</sub>	Weak pull-down equivalent resistance	20	-	50	k $\Omega$

Table 33 AC Characteristics ( $T_A=25^\circ C$ )

-	Symbol	Parameter	Condition	3.3V		5V		Unit
				Minimum value	Maximum value	Minimum value	Maximum value	
NA	$t_{f(I/O)out}$	Output fall time from high to low level	$C_L=25pF$	8	14.3	4.1	12	ns
	$t_{r(I/O)out}$	Output rise time from low to high level		7.8	15.4	4.3	12.4	ns
	$t_{f(I/O)out}$	Output fall time from high to low level	$C_L=50pF$	10.3	23.6	7.2	15.1	ns
	$t_{r(I/O)out}$	Output rise time from low to high level		11	23.6	6.9	15.7	ns
	$t_{f(I/O)out}$	Output fall time from high to low level	$C_L=200pF$	23.4	56.5	20.2	33.7	ns
	$t_{r(I/O)out}$	Output rise time from low to high level		23.2	61.9	20.6	35.1	ns
0 (GPIO-HD)	$t_{f(I/O)out}$	Output fall time from high to low level	$C_L=25pF$	8	14.3	4.1	12	ns
	$t_{r(I/O)out}$	Output rise time from low to high level		7.8	15.4	4.3	12.4	ns
	$t_{f(I/O)out}$	Output fall time from high to low level	$C_L=50pF$	10.3	23.6	7.2	15.1	ns
	$t_{r(I/O)out}$	Output rise time from low to high level		11	23.6	6.9	15.7	ns
	$t_{f(I/O)out}$	Output fall time from high to low level	$C_L=200pF$	23.4	56.5	20.2	33.7	ns
	$t_{r(I/O)out}$	Output rise time from low to high level		23.2	61.9	20.6	35.1	ns
1 (GPIO-HD)	$t_{f(I/O)out}$	Output fall time from high to low level	$C_L=25pF$	2.9	8.2	2.5	5	ns
	$t_{r(I/O)out}$	Output rise time from low to high level		2.9	7	2	4.1	ns
	$t_{f(I/O)out}$	Output fall time from high to low level	$C_L=50pF$	5.5	11.1	4.3	6.9	ns

-	Symbol	Parameter	Condition	3.3V		5V		Unit
				Minimum value	Maximum value	Minimum value	Maximum value	
	$t_{r(I/O)out}$	Output rise time from low to high level	$C_L=200pF$	4.3	9.5	3.4	5.8	ns
	$t_{f(I/O)out}$	Output fall time from high to low level		11.2	22.4	8.1	14.8	ns
	$t_{r(I/O)out}$	Output rise time from low to high level		9.5	21.1	7	14.3	ns

## 7.6 Communication peripherals

### 7.6.1 Electrical characteristics of LPUART

For information about the characteristics of LPUART, please refer to General AC specifications section.

#### 7.6.1.1 Baud rate

Baud rate=Baud clock/((OSRCFG+1) \* BRMD).

For information about baud rate, please refer to the description of "Baud Rate " in the *User Manual*.

### 7.6.2 Electrical characteristics of LPSPI

1. The Low-Power Serial Peripheral Interface (LPSPI) provides synchronous serial bus, and performs master operations and slave operations. Many transmission properties are programmable.
2. The maximum output load for all measurements is 50pF, the input conversion time is 1ns, and the solder pad is configured with the fastest rotation setting (DSCFG=1).
3. All time data in electrical characteristics of LPSP is related to 20%  $V_{DD}$  and 80%  $V_{DD}$  thresholds.

#### 7.6.2.1 Electrical characteristics of LPSPI run mode

Table 34 Electrical Characteristics of LPSPI Run Mode<sup>(1)</sup>

Symbol	Parameter	Condition	Run mode <sup>(2)</sup>						Unit
			3.3V IO			5V IO			
			Minimum value	Typical value	Maximum value	Minimum value	Typical value	Maximum value	
$f_P$	Peripheral Clock Frequency	Master Mode	-	-	40	-	-	40	MHz
		Slave Mode	-	-	40	-	-	40	

Symbol	Parameter	Condition	Run mode <sup>(2)</sup>						Unit
			3.3V IO			5V IO			
			Minimum value	Typical value	Maximum value	Minimum value	Typical value	Maximum value	
	<sup>(3)</sup>	Main loop (low speed) <sup>(4)</sup>	-	-	48	-	-	48	
		Main loop <sup>(5)</sup>	-	-	48	-	-	40	
f <sub>LPSPi</sub>	Operating Frequency	Master Mode	-	-	10	-	-	10	
		Slave Mode	-	-	10	-	-	10	
		Main loop (low speed) <sup>(4)</sup>	-	-	12	-	-	12	
		Main loop <sup>(5)</sup>	-	-	12	-	-	20	
t <sub>SPSCK</sub>	SPSCK cycle	Master Mode	100	-	-	100	-	-	ns
		Slave Mode	100	-	-	100	-	-	
		Main loop (low speed) <sup>(4)</sup>	83	-	-	83	-	-	
		Main loop <sup>(5)</sup>	83	-	-	50	-	-	
t <sub>hyst</sub> <sup>(6)</sup>	Enable delay time after SPSCK delay	Slave Mode	-	-	-	-	-	-	ns
		Master Mode	(SPDCFG+1)*t <sub>p-25</sub>	-	-	(SPDCFG+1)*t <sub>p-25</sub>	-	-	
		Main loop (low speed) <sup>(4)</sup>							
		Main loop <sup>(5)</sup>							
t <sub>LEAD</sub> <sup>(7)</sup>	Enable lead	Slave Mode	-	-	-	-	-	-	ns



Symbol	Parameter	Condition	Run mode <sup>(2)</sup>						Unit
			3.3V IO			5V IO			
			Minimum value	Typical value	Maximum value	Minimum value	Typical value	Maximum value	
	time, PCS to SPSCK delay	Master Mode							
		Main loop (low speed) <sup>(4)</sup>	(PSDCFG+1)*t <sub>p</sub> -25	-	-	(PSDCFG+1)*t <sub>p</sub> -25	-	-	
		Main loop <sup>(5)</sup>							
t <sub>wspscck</sub> <sup>(8)</sup>	Time of high SPSCK clock or low SPSCK clock	Master Mode							
		Slave Mode							
		Main loop (low speed) <sup>(4)</sup>	t <sub>spscck</sub> /2-3	-	t <sub>spscck</sub> /2+3	t <sub>spscck</sub> /2-3	-	t <sub>spscck</sub> /2+3	ns
		Main loop <sup>(5)</sup>							
t <sub>ac</sub>	Slave access time	Slave Mode	-	-	50	-	-	50	ns
t <sub>dis</sub>	Slave MISO (SOUT) disable time	Slave Mode	-	-	50	-	-	50	ns
t <sub>su(in)</sub>	Data input setup time	Master Mode	38	-	-	29	-	-	
		Slave Mode	5	-	-	3	-	-	
		Main loop (low speed) <sup>(4)</sup>	10	-	-	8	-	-	ns
		Main loop <sup>(5)</sup>	8	-	-	7	-	-	
t <sub>h(in)</sub>		Master Mode	0	-	-	0	-	-	ns

Symbol	Parameter	Condition	Run mode <sup>(2)</sup>						Unit
			3.3V IO			5V IO			
			Minimum value	Typical value	Maximum value	Minimum value	Typical value	Maximum value	
	Data input hold time	Slave Mode	3	-	-	3	-	-	
		Main loop (low speed) <sup>(4)</sup>	3	-	-	3	-	-	
		Main loop <sup>(5)</sup>	3	-	-	3	-	-	
$t_{h(out)}$	Data output hold time	Master Mode	22	-	-	15	-	-	ns
		Slave Mode	4	-	-	4	-	-	
		Main loop (low speed) <sup>(4)</sup>	22	-	-	22	-	-	
		Main loop <sup>(5)</sup>	14	-	-	10	-	-	
$t_v$	Data validity time after SPSCK edge	Master Mode	-	-	16	-	-	12	ns
		Slave Mode	-	-	39	-	-	30	
		Main loop (low speed) <sup>(4)</sup>	-	-	10	-	-	8	
		Main loop <sup>(5)</sup>	-	-	16	-	-	12	
$t_{r(in)}$ $t_{f(in)}$	Data input rise and fall time	Master Mode	-	-	1	-	-	1	ns
Slave Mode									
Main loop (low speed) <sup>(4)</sup>									
Main loop <sup>(5)</sup>									

Symbol	Parameter	Condition	Run mode <sup>(2)</sup>						Unit
			3.3V IO			5V IO			
			Minimum value	Typical value	Maximum value	Minimum value	Typical value	Maximum value	
$t_{r(out)}$ $t_{f(out)}$	Data output rise and fall time	Master Mode	-	-	25	-	-	25	ns
	Slave Mode								
	Main loop (low speed) <sup>(4)</sup>								
	Main loop <sup>(5)</sup>								

Notes:

- (1) When enabling the main loop mode, the trace length of the SCK pad shall be less than or equal to 11 inches.
- (2) When switching from HSR mode to RUN mode, the output clock of LPSPi shall be less than or equal to 14MHz.
- (3)  $f_P$ = LPSPi peripheral clock,  $t_P=1/f_P$ .
- (4) Main loop mode (low speed): The same as the configuration and function of main loop mode in (5), only applicable to LPSPi0, and the difference is, at low speed, the clock pad PMB2 is used.
- (5) Main loop mode: In this mode, set LPSPi\_CFGR1[SAMPLE] to 1, and enable LPSPi\_SCK clock delay for sampling input data, only applicable to LPSPi0. The clock pads used are PMD15 and PME0.
- (6) The baud rate clock of LPSPi is delayed for at least 1 cycle. Set SPDCFG to 0, and the range of SPDCFG is 0~255.
- (7) The baud rate clock of LPSPi is delayed for at least 1 cycle. Set PSDCFG to 0, and the range of PSDCFG is 0~255.
- (8) When selecting an odd number frequency divider, ensure that the duty cycle conforms to this parameter.

### 7.6.2.2 Electrical characteristics of LPSPi high-speed run mode

Table 35 Electrical Characteristics of LPSPi High-speed Run Mode <sup>(1)</sup>

Symbol	Parameter	Condition	High-speed run mode <sup>(2)</sup>						Unit
			3.3V IO			5V IO			
			Minimum value	Typical value	Maximum value	Minimum value	Typical value	Maximum value	
$f_P$	Peripheral Clock Frequency <sup>(3)</sup>	Master Mode	-	-	56	-	-	56	MHz
		Slave Mode	-	-	56	-	-	56	

Symbol	Parameter	Condition	High-speed run mode <sup>(2)</sup>						Unit
			3.3V IO			5V IO			
			Minimum value	Typical value	Maximum value	Minimum value	Typical value	Maximum value	
		Main loop (low speed) <sup>(4)</sup>	-	-	48	-	-	48	
		Main loop <sup>(5)</sup>	-	-	48	-	-	48	
		Master Mode	-	-	14 <sup>(6)</sup>	-	-	14	
		Slave Mode	-	-	14 <sup>(6)</sup>	-	-	14	
f <sub>LPSPI</sub>	Operating Frequency	Main loop (low speed) <sup>(4)</sup>	-	-	12	-	-	12	
		Main loop <sup>(5)</sup>	-	-	12	-	-	24	
		Master Mode	72	-	-	72	-	-	
		Slave Mode	72	-	-	72	-	-	
t <sub>SPSCK</sub>	SPSCK cycle	Main loop (low speed) <sup>(4)</sup>	83	-	-	83	-	-	ns
		Main loop <sup>(5)</sup>	83	-	-	42	-	-	
		Slave Mode	-	-	-	-	-	-	
		Master Mode	(SPDCFG+1)*t <sub>p-25</sub>	-	-	(SPDCFG+1)*t <sub>p-25</sub>	-	-	
t <sub>hyst</sub> <sup>(7)</sup>	Enable delay time after SPSCK delay	Main loop (low speed) <sup>(4)</sup>	(SPDCFG+1)*t <sub>p-25</sub>	-	-	(SPDCFG+1)*t <sub>p-25</sub>	-	-	ns
		Master Mode							
		Slave Mode							

Symbol	Parameter	Condition	High-speed run mode <sup>(2)</sup>						Unit
			3.3V IO			5V IO			
			Minimum value	Typical value	Maximum value	Minimum value	Typical value	Maximum value	
		Main loop <sup>(5)</sup>							
$t_{LEAD}^{(8)}$	Enable lead time, PCS to SPSCK delay	Slave Mode	-	-	-	-	-	-	ns
		Master Mode	$(PSDCFG+1)*t_p-25$	-	-	$(PSDCFG+1)*t_p-25$	-	-	
		Main loop (low speed) <sup>(4)</sup>							
		Main loop <sup>(5)</sup>							
$t_{WSPSCK}^{(9)}$	Time of high SPSCK clock or low SPSCK clock	Master Mode	$t_{spck}/2-3$	-	$t_{spck}/2+3$	$t_{spck}/2-3$	-	$t_{spck}/2+3$	ns
		Slave Mode							
		Main loop (low speed) <sup>(4)</sup>							
		Main loop <sup>(5)</sup>							
$t_{ac}$	Slave access time	Slave Mode	-	-	50	-	-	50	ns
$t_{dis}$	Slave MISO(SO UT) disable time	Slave Mode	-	-	50	-	-	50	ns
$t_{su(in)}$	Data input setup time	Master Mode	$37^{(10)}$	-	-	26	-	-	ns
		Slave Mode	5	-	-	3	-	-	

Symbol	Parameter	Condition	High-speed run mode <sup>(2)</sup>						Unit
			3.3V IO			5V IO			
			Minimum value	Typical value	Maximum value	Minimum value	Typical value	Maximum value	
		Main loop (low speed) <sup>(4)</sup>	9	-	-	7	-	-	
		Main loop <sup>(5)</sup>	7	-	-	5	-	-	
$t_{h(in)}$	Data input hold time	Master Mode	0	-	-	0	-	-	ns
		Slave Mode	3	-	-	3	-	-	
		Main loop (low speed) <sup>(4)</sup>	3	-	-	3	-	-	
		Main loop <sup>(5)</sup>	3	-	-	2	-	-	
$t_{h(out)}$	Data output hold time	Master Mode	23	-	-	15	-	-	ns
		Slave Mode	4	-	-	4	-	1	
		Main loop (low speed) <sup>(4)</sup>	22	-	-	15	-	-	
		Main loop <sup>(5)</sup>	14	-	-	10	-	-	
$t_v$	Data validity time after SPCK edge	Master Mode	-	-	15	-	-	11	ns
		Slave Mode	-	-	36 <sup>(10)</sup>	-	-	26	
		Main loop (low speed) <sup>(4)</sup>	-	-	9	-	-	7	

Symbol	Parameter	Condition	High-speed run mode <sup>(2)</sup>						Unit
			3.3V IO			5V IO			
			Minimum value	Typical value	Maximum value	Minimum value	Typical value	Maximum value	
		Main loop <sup>(5)</sup>	-	-	15	-	-	11	
$t_{r(in)}$ $t_{f(in)}$	Data input rise and fall time	Master Mode							ns
		Slave Mode							
		Main loop (low speed) <sup>(4)</sup>	-	-	1	-	-	1	
		Main loop <sup>(5)</sup>							
$t_{r(out)}$ $t_{f(out)}$	Data output rise and fall time	Master Mode							ns
		Slave Mode							
		Main loop (low speed) <sup>(4)</sup>	-	-	25	-	-	25	
		Main loop <sup>(5)</sup>							

Notes:

- (1) When enabling the main loop mode, the trace length of the SCK pad shall be less than or equal to 11 inches.
- (2) When switching from HSR mode to RUN mode, the output clock of LPSPI shall be less than or equal to 14MHz.
- (3)  $f_P$ = LPSPI peripheral clock,  $t_P=1/f_P$ .
- (4) Main loop mode (low speed): The same as the configuration and function of main loop mode in (5), only applicable to LPSPI0, and the difference is, at low speed, the clock pad PMB2 is used.
- (5) Main loop mode: In this mode, set LPSPI\_CFGFR1[SAMPLE] to 1, and enable LPSPI\_SCK clock delay for sampling input data, only applicable to LPSPI0. The clock pads used are PMD15 and PME0.
- (6) Only GPIO-HD PAD type LPSPI0 can achieve the maximum operating frequency  $f_{LPSPI}$ . Otherwise,  $f_{LPSPI}=12Mhz$ .
- (7) The baud rate clock of LPSPI is delayed for at least 1 cycle. Set SPDCFG to 0, and the range of SPDCFG is 0~255.

- (8) The baud rate clock of LPSPI is delayed for at least 1 cycle. Set PSDCFG to 0, and the range of PSDCFG is 0~255.
- (9) When selecting an odd number frequency divider, ensure that the duty cycle conforms to this parameter.
- (10) The maximum operating frequency  $f_{LPSPI}=12\text{MHz}$ , which has nothing to do with the PAD type and LPSPI instance.
- (11) Only applicable to GPIO-HD PAD type LPSPI0, with a maximum operating frequency of  $f_{LPSPI}=14\text{MHz}$ .

### 7.6.2.3 Electrical characteristics of LPSPI VLPR mode

Table 36 Electrical Characteristics of LPSPI VLPR Mode <sup>(1)</sup>

Symbol	Parameter	Condition	VLPR mode						Unit
			3.3V IO			5V IO			
			Minimum value	Typical value	Maximum value	Minimum value	Typical value	Maximum value	
$f_P$	Peripheral Clock Frequency <sup>(2)</sup>	Master Mode	-	-	4	-	-	4	MHz
		Slave Mode	-	-	4	-	-	4	
		Main loop (low speed) <sup>(3)</sup>	-	-	4	-	-	4	
		Main loop <sup>(4)</sup>	-	-	4	-	-	4	
$f_{LPSPI}$	Operating Frequency	Master Mode	-	-	2	-	-	2	MHz
		Slave Mode	-	-	2	-	-	2	
		Main loop (low speed) <sup>(3)</sup>	-	-	2	-	-	2	
		Main loop <sup>(4)</sup>	-	-	2	-	-	2	
$t_{SPCK}$	SPSCK cycle	Master Mode	500	-	-	500	-	-	ns
		Slave Mode	500	-	-	500	-	-	
		Main loop (low speed) <sup>(3)</sup>	500	-	-	500	-	-	



Symbol	Parameter	Condition	VLPR mode						Unit
			3.3V IO			5V IO			
			Minimum value	Typical value	Maximum value	Minimum value	Typical value	Maximum value	
		Main loop <sup>(4)</sup>	500	-	-	500	-	-	
$t_{\text{hyst}}^{(6)}$	Enable delay time after SPSCK delay	Slave Mode	-	-	-	-	-	-	ns
		Master Mode	$(\text{SPDCFG} + 1) \cdot t_p - 50$	-	-	$(\text{SPDCFG} + 1) \cdot t_p - 50$	-	-	
		Main loop (low speed) <sup>(3)</sup>							
		Main loop <sup>(4)</sup>							
$t_{\text{LEAD}}^{(7)}$	Enable lead time, PCS to SPSCK delay	Slave Mode	-	-	-	-	-	ns	
		Master Mode	$(\text{PSDCFG} + 1) \cdot t_p - 50$	-	-	$(\text{PSDCFG} + 1) \cdot t_p - 50$	-		-
		Main loop (low speed) <sup>(3)</sup>							
		Main loop <sup>(4)</sup>							
$t_{\text{wSPSCK}}^{(8)}$	Time of high SPSCK clock or low SPSCK clock	Master Mode	$t_{\text{spscK}}/2-5$	-	$t_{\text{spscK}}/2+5$	$t_{\text{spscK}}/2-5$	-	$t_{\text{spscK}}/2+5$	ns
		Slave Mode							
		Main loop (low speed) <sup>(3)</sup>							
		Main loop <sup>(4)</sup>							
$t_{\text{ac}}$	Slave access time	Slave Mode	-	-	100	-	-	100	ns

Symbol	Parameter	Condition	VLPR mode						Unit
			3.3V IO			5V IO			
			Minimum value	Typical value	Maximum value	Minimum value	Typical value	Maximum value	
$t_{dis}$	Slave MISO (SOUT) disable time	Slave Mode	-	-	100	-	-	100	ns
$t_{su(in)}$	Data input setup time	Master Mode	78	-	-	72	-	-	ns
		Slave Mode	18	-	-	18	-	-	
		Main loop (low speed) (3)	20	-	-	20	-	-	
		Main loop (4)	20	-	-	20	-	-	
$t_{h(in)}$	Data input hold time	Master Mode	0	-	-	0	-	-	ns
		Slave Mode	14	-	-	14	-	-	
		Main loop (low speed) (3)	12	-	-	12	-	-	
		Main loop (4)	11	-	-	11	-	-	
$t_{h(out)}$	Data output hold time	Master Mode	29	-	-	22	-	-	ns
		Slave Mode	4	-	-	4	-	-	
		Main loop (low speed) (3)	27	-	-	21	-	-	
		Main loop (4)	19	-	-	14	-	-	
$t_v$	Data validity time after	Master Mode	-	-	48	-	-	47	ns
		Slave Mode	-	-	96	-	-	92	

Symbol	Parameter	Condition	VLPR mode						Unit
			3.3V IO			5V IO			
			Minimum value	Typical value	Maximum value	Minimum value	Typical value	Maximum value	
	SPSCK edge	Main loop (low speed) (3)	-	-	44	-	-	44	
		Main loop (4)	-	-	48	-	-	47	
$t_{r(in)}$ $t_{f(in)}$	Data input rise and fall time	Master Mode							ns
		Slave Mode							
		Main loop (low speed) (3)	-	-	1	-	-	1	
		Main loop (4)							
$t_{r(out)}$ $t_{f(out)}$	Data output rise and fall time	Master Mode							ns
		Slave Mode							
		Main loop (low speed) (3)	-	-	25	-	-	25	
		Main loop (4)							

Notes:

- (1) When enabling the main loop mode, the trace length of the SCK pad shall be less than or equal to 11 inches.
- (2)  $f_P$ = LPSPi peripheral clock,  $t_P=1/f_P$ .
- (3) Main loop mode (low speed): The same as the configuration and function of main loop mode in (4), only applicable to LPSPi0, and the difference is, at low speed, the clock pad PMB2 is used.
- (4) Main loop mode: In this mode, set LPSPi\_CFGR1[SAMPLE] to 1, and enable LPSPi\_SCK clock delay for sampling input data, only applicable to LPSPi0. The clock pads used are PMD15 and PME0.
- (5) Only GPIO-HD PAD type LPSPi0 can achieve the maximum operating frequency  $f_{LPSPi}$ . Otherwise,  $f_{LPSPi}=12\text{MHz}$ .
- (6) The baud rate clock of LPSPi is delayed for at least 1 cycle. Set SPDCFG to 0, and the range of SPDCFG is 0~255.

- (7) The baud rate clock of LPSPI is delayed for at least 1 cycle. Set PSDCFG to 0, and the range of PSDCFG is 0~255.
- (8) When selecting an odd number frequency divider, ensure that the duty cycle conforms to this parameter.

Figure 9 LPSPI Main Mode Timing (CLKPHA=0)

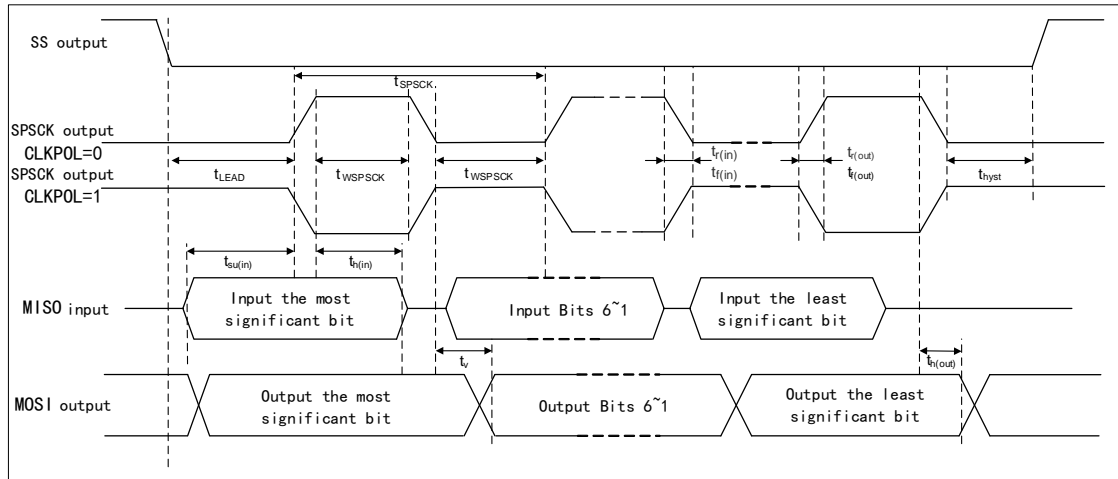

Notes:

- (1) When BSEN=0, the input sequence of MISO is MSB, No. 6-1 bits, LSB.
- (2) When BSEN=1, the input sequence of MISO is LSB, No. 1-6 bits, MSB.

Figure 10 LPSPI Master Mode Timing (CLKPHA=1)

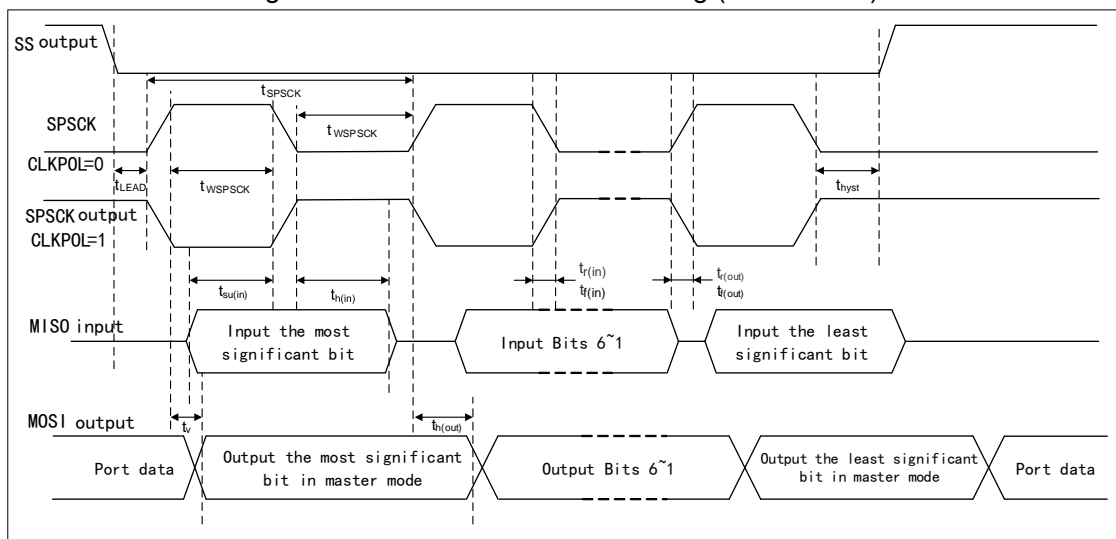

Notes:

- (1) When BSEN=0, the input sequence of MISO is MSB, No. 6-1 bits, LSB.
- (2) When BSEN=1, the input sequence of MISO is LSB, No. 1-6 bits, MSB.

Figure 11 LPSPI Slave Mode Timing (CLKPHA=0)

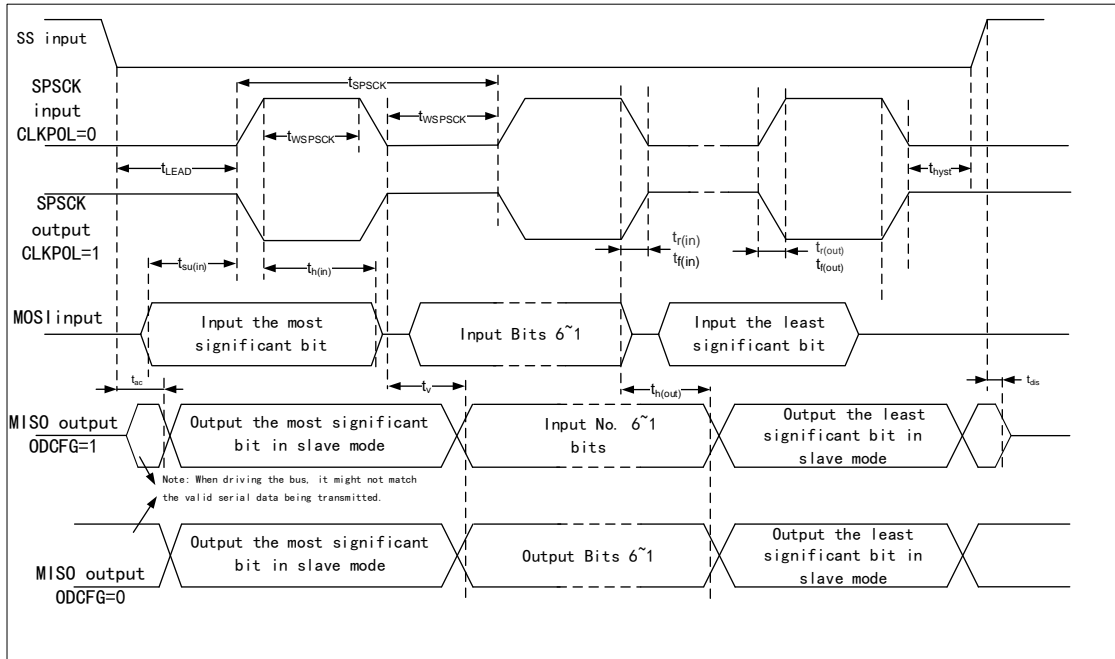
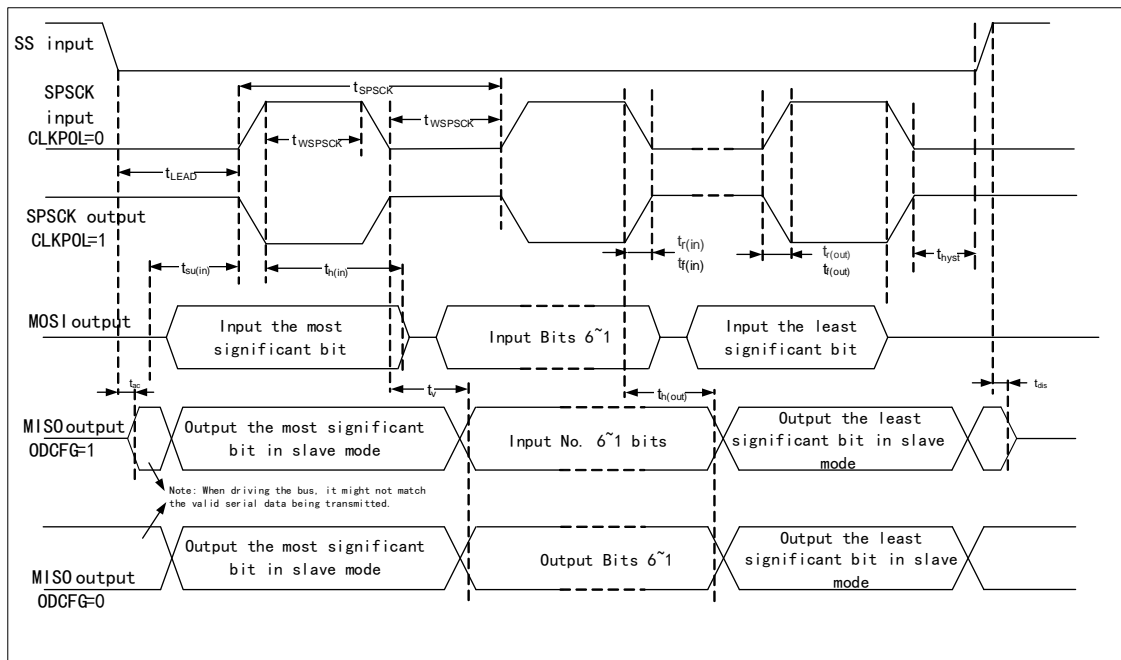

Figure 12 LPSPI Slave Mode Timing (CLKPHA=1)



### 7.6.3 Electrical characteristics of LPI2C

For information about the characteristics of LPI2C, please refer to General AC specifications section.

For LPI2C configuration information, please refer to the *User Manual*.

### 7.6.4 Electrical characteristics of CAN

For the bit timing parameters and baud rate required for setting the CAN protocol, please refer to the " Functional differences among different CAN " section of the *CAN User Manual*.

## 7.7 Analog peripherals

### 7.7.1 ADC

#### 7.7.1.1 Operating conditions of 12-bit ADC

Table 37 Operating conditions of 12-bit ADC<sup>(1)</sup>

Symbol	Parameter	Condition	Minimum value	Typical value <sup>(2)</sup>	Maximum value	Unit
V <sub>REFH</sub>	High reference voltage <sup>(3)</sup>	-	Please refer to the "Voltage and Current Operating Requirements " section for relevant data	V <sub>DDA</sub>	Please refer to the "Voltage and Current Operating Requirements " section for relevant data	V
V <sub>REFL</sub>	Low reference voltage <sup>(3)</sup>	-	Please refer to the "Voltage and Current Operating Requirements " section for relevant data	0	Please refer to the "Voltage and Current Operating Requirements " section for relevant data	mV
V <sub>IN</sub>	ADC input voltage	-	V <sub>REFL</sub>	-	V <sub>REFH</sub>	V
f <sub>ADC</sub>	ADC frequency	Normal use <sup>(4-5)</sup>	2	40	50	MHz
C <sub>PIN</sub>	Pin capacitance	-	-	2.1	2.5	pF
C <sub>ABUS</sub>	Analog bus capacitance	-	-	3	4	

Symbol	Parameter	Condition	Minimum value	Typical value <sup>(2)</sup>	Maximum value	Unit
C <sub>ADC</sub>	Sampling capacitance	-	-	5.1(gain=0).. .7.2(gain=maximum)	6.36(gain=0).. .9.36(gain=maximum)	
R <sub>SRC</sub>	Source impedance	f <sub>ADC</sub> <4MHz	-	-	5	kΩ
R <sub>CH</sub>	Channel impedance(channel select switch impedance)	-	-	0.650	0.780	
R <sub>ADC</sub>	Sampling impedance(sampling select switch impedance)	-	-	0.155	1.0	
f <sub>CONV</sub>	ADC conversion frequency <sup>(7-8)</sup>	There is no ADC average hardware <sup>(6)</sup> to enable continuous conversion and subsequent conversion time	46.4	928	1160	Ksps
		Configure the ADC average hardware to 32 <sup>(6)</sup> , and enable continuous conversion and subsequent conversion time	1.45	29	36.25	Ksps
	ADC power consumption	-	-	1.0	1.1 <sup>(9)</sup>	mA

Notes:

- (1) The data is obtained from a comprehensive evaluation and is not tested in production.
- (2) Unless otherwise specified, the parameter conditions of typical values are T<sub>A</sub>=25°C, V<sub>DDA</sub>=5V, f<sub>ADC</sub>=40MHz, R<sub>AS</sub>=20Ω and C<sub>AS</sub>=10nF.
- (3) V<sub>REFH</sub> and V<sub>REFL</sub> are internally connected to V<sub>DDA</sub> and V<sub>SS</sub>. When the reference voltage quality is better than SAR ADC, the maximum performance can be obtained.
- (4) Refer to the User Manual to set the clock and comparison cycle.
- (5) When the frequency is greater than the maximum frequency of the ADC, the ADC conversion is unstable.
- (6) The average template number of hardware can be configured by ADC\_CSTS3[HAVGCFG].
- (7) This value is tested under the condition of the minimum sampling time of 275ns.
- (8) For ADC conversion rate calculation, please refer to the description of "Calibration Function" in *User Manual*.

- (9) The test conditions for configuration parameters are:
- $V_{DD}=V_{DDA}=V_{REFH}=2.5V-5.5V$ ,  $T_A=-40^{\circ}C-135^{\circ}C$
  - The bus clock frequency is 48MHz, the ADC time frequency is 48MHz (using HSICLK), the calibration clock is 24MHz, the sampling time is  $t_S=14cyc$ , and the ADC hardware averaging time is 3212-bit resolution
  - Continuous conversion mode
  - ADC0\_CH1 channel

Figure 13 ADC Input Impedance Equivalent Diagram

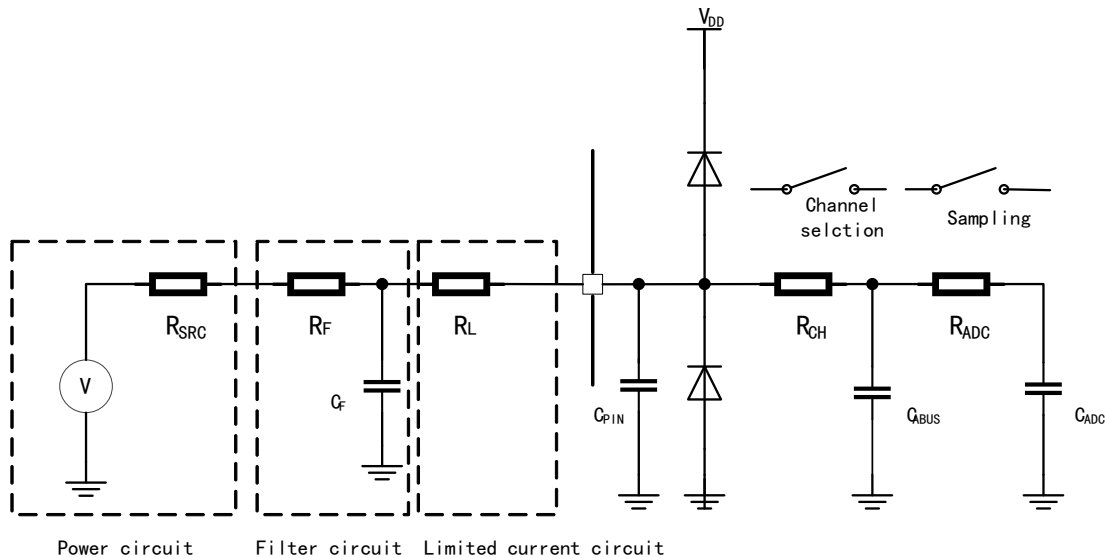

Table 38 Meanings of Symbols in ADC Input Impedance Equivalent Diagram

Symbol	Meaning
$R_L$	Current limiting resistance
$R_{SRC}$	Source impedance
$R_F$	Filter resistance
$R_{CH}$	Channel impedance
$R_{ADC}$	Sampling impedance
$C_{ADC}$	Sampling capacitance
$C_{ABUS}$	Analog bus capacitance
$C_{PIN}$	Pin capacitance
$C_F$	Filter capacitance

### 7.7.1.2 Electrical characteristics of 12-bit ADC

Notes:

- (1) When two ADC are operated in parallel or simultaneous, no matter whether sampling is conducted through the same channel of two ADC or through different channels of each ADC, it may lead to reduction of ADC performance. In order to reduce the impact of synchronous conversion, it is



necessary to stagger the conversions of two ADC, especially in the sampling phase.

- (2) Since the ADC reference pin and power pin share the pin package, ADC simulation performance characteristics may be affected by external PCB layout. So it is necessary to pay attention to PCB wiring.
- (3) All accuracy assumes that the ADC is calibrated with  $V_{REFH}=V_{DDA}=V_{DD}$ , and the calibration frequency is set to be less than or equal to half of the maximum designated ADC clock frequency.

Table 39 12-bit ADC Characteristics ( $V_{DD}=2.7V-4V$ ) ( $V_{DDA}=V_{REFH}$ ,  $V_{SS}=V_{REFL}$ )

Symbol	Parameter	Condition	Minimum value	Typical value <sup>(1)</sup>	Maximum value	Unit
$V_{DDA}$	Supply voltage	-	2.7	-	4	V
$I_{DDA\_ADC}$	Supply current of each ADC <sup>(2)</sup>	-	-	0.6	-	mA
$t_s$	Sampling time	-	275	-	Please refer to the <i>User Manual</i>	ns
$E_T^{(3)}$	Composite error <sup>(5-9)</sup>	-	-	$\pm 4$	$\pm 8$	LSB <sup>(4)</sup>
$E_D$	Differential linear error <sup>(5-9)</sup>	-	-	$\pm 1.2$	-	
$E_L$	Integral linear error <sup>(5-9)</sup>	-	-	$\pm 1.7$	-	

Notes:

- (1) Unless otherwise specified, the parameter conditions of typical values are  $T_A=25^\circ C$ ,  $V_{DDA}=3V$ ,  $f_{ADC}=16MHz$ ,  $R_{AS}=20\Omega$  and  $C_{AS}=10nF$ .
- (2) The ADC conversion rate affects the ADC supply current.
- (3) Represents composite error, including offset and full-scale error.
- (4)  $1\text{ LSB}=(V_{REFH}-V_{REFL})/2^N$
- (5) The parameter is the average value during running only in an independent mode. The performance may decrease according to the usage of the equipment. For the average value of ADC, please refer to the User Manual to determine the optimal setting of ADC\_CSTS3[HAVGCFG].
- (6) In the ADC signals near  $V_{DD}/V_{SS}$ , XTAL/EXTAL or high-frequency switch pins, the performance of ADC may decrease.
- (7) These values can ensure the performance of the ADC on multiple ADC input channel pins. When ADC is used to monitor internal analog parameters, it is assumed that the performance decreases.
- (8) All parameters in the table are parameters of the ADC clock source provided by the system clock.
- (9) In high and low temperature environments, it is recommended that the ADC clock be 16MHz to ensure the accuracy of the results.

Table 40 12-bit ADC Characteristics ( $V_{DD}=4V-5.5V$ ) ( $V_{DDA}=V_{REFH}$ ,  $V_{SS}=V_{REFL}$ )

Symbol	Parameter	Condition	Minimum value	Typical value <sup>(1)</sup>	Maximum value	Unit
$V_{DDA}$	Supply voltage	-	4	-	5.5	V
$I_{DDA\_ADC}$	Supply current of each ADC <sup>(2)</sup>	-	-	1	-	mA
$t_s$	Sampling time	-	275	-	Please refer to the <i>User Manual</i>	ns
$E_T$ <sup>(3)</sup>	Composite error <sup>(5-9)</sup>	-	-	$\pm 4$	$\pm 8$	LSB <sup>(4)</sup>
$E_D$	Differential non-linearity <sup>(5-9)</sup>	-	-	$\pm 0.8$	-	
$E_L$	Integral non-linearity <sup>(5-9)</sup>	-	-	$\pm 1.4$	-	

Notes:

- (1) Unless otherwise specified, the parameter conditions of typical values are  $T_A=25^\circ C$ ,  $V_{DDA}=5V$ ,  $f_{ADC}=40MHz$ ,  $R_{AS}=20\Omega$  and  $C_{AS}=10nF$ .
- (2) The ADC conversion rate affects the ADC supply current.
- (3) Represents static error, including offset and full-scale error.
- (4)  $1\text{ LSB}=(V_{REFH}-V_{REFL})/2^N$
- (5) The parameter is the average value during running only in an independent mode. The performance may decrease according to the usage of the equipment. For the average value of ADC, please refer to the User Manual to determine the optimal setting of ADC\_CSTS3[HAVGCFG].
- (6) In the ADC signals near  $V_{DD}/V_{SS}$ , XTAL/EXTAL or high-frequency switch pins, the performance of ADC may decrease.
- (7) These values can ensure the performance of the ADC on multiple ADC input channel pins. When ADC is used to monitor internal analog parameters, it is assumed that the performance decreases.
- (8) All parameters in the table are parameters of the ADC clock source provided by the system clock.

Notes:

- (1) The use of triple bonding in packages such as LQFP100 and LQFP64 can lead to a decrease in ADC performance.

## 7.7.2 Comparator with internal 8-bit DAC

Table 41 Electrical Characteristics of Comparator with internal 8-bit DAC

Symbol	Parameter	Condition		Minimum value	Typical value	Maximum value	Unit
$I_{DDH}$	Supply current (1)	High-speed mode	-40°C - 125°C	-	230	300	$\mu\text{A}$
$I_{DDL}$		Low-speed mode	-40°C - 125°C	-	6	13	
$V_{IN}$	DAC input voltage(Analog input voltage) (1)	-		0	0- $V_{DDA}$	$V_{DDA}$	V
$V_{OSH}$	Input offset voltage	High-speed mode	-40°C - 125°C	-25	$\pm 1$	25	mV
$V_{OSL}$	Input offset voltage	Low-speed mode	-40°C - 125°C	-40	$\pm 4$	40	
$t_{PDH\_100}$	Propagation delay <sup>(2)</sup>	High-speed mode	-40°C - 125°C	-	35	300	ns
$t_{PDL\_100}$		Low-speed mode	-40°C - 125°C	-	0.5	3	$\mu\text{s}$
$t_{PDH\_30}$	Propagation delay <sup>(3)</sup>	High-speed mode	-40°C - 125°C	-	70	500	ns
$t_{PDL\_30}$		Low-speed mode	-40°C - 125°C	-	1	5	$\mu\text{s}$
$t_{IDH}$	Initialization delay <sup>(4)</sup>	High-speed mode	-40°C - 125°C	-	1.5	3	
$t_{IDL}$		Low-speed mode	-40°C - 125°C	-	10	30	
$V_{hyst0}$	Analog comparator hysteresis	hyst0	-40°C - 125°C	-	0	-	mV
$V_{hyst1}$		hyst1 High-speed mode	-40°C - 125°C	-	19	66	
		hyst1 Low-speed mode	-40°C - 125°C	-	15	40	

Symbol	Parameter	Condition		Minimum value	Typical value	Maximum value	Unit
V <sub>hyst2</sub>		hyst2 High-speed mode	-40°C - 125°C	-	34	133	
		hyst2 Low-speed mode	-40°C - 125°C	-	23	80	
V <sub>hyst3</sub>		hyst3 High-speed mode	-40°C - 125°C	-	46	200	
		hyst3 Low-speed mode	-40°C - 125°C	-	32	120	
I <sub>DAC8</sub>	8-bit DAC current adder (enabled)	3.3V reference voltage		-	6	9	μA
		5V reference voltage		-	10	16	
E <sub>D</sub>	Differential linear error	-		-0.5	-	0.5	LSB <sup>(6)</sup>
E <sub>L</sub>	Integral linear error <sup>(5)</sup>	-		-0.75	-	0.75	
t <sub>is</sub>	Initialization and switching stability time	-		-	-	30	μs

**Notes:**

- (1) Voltage input difference of I<sub>DDH</sub>/DDL is >200mV
- (2) Apply ±(100mV + V<sub>hyst0/1/2/3</sub> + maximum V<sub>OSH/OSL</sub>) around the switching point.
- (3) Apply ±(30mV + 2 \* V<sub>hyst0/1/2/3</sub> + maximum V<sub>OSH/OSL</sub>) around the switching point.
- (4) Apply ±(100mV + V<sub>hyst0/1/2/3</sub>).
- (5) Calculate through linear regression least square method.
- (6) 1LSB=reference voltage/256

Note: If the input signal of the comparator is close to V<sub>DD</sub>/V<sub>SS</sub> or XTAL/EXTAL or switch pins, cross coupling may occur, which can be solved by setting hysteresis to obtain the comparator performance. Besides, when performing noise filtering on the input signals, an external capacitor (1nF) shall be used. And the source driver shall not be weak (it is recommended that the signal pull up/pull down be less than 50K).

The curve below shows Level-3 hysteresis, Level-2 hysteresis, Level-1 hysteresis, and Level-0 hysteresis from top to bottom.

Figure 14 Typical hysteresis vs. Vin level (V<sub>DDA</sub>=3.3V,PMSEL=0)

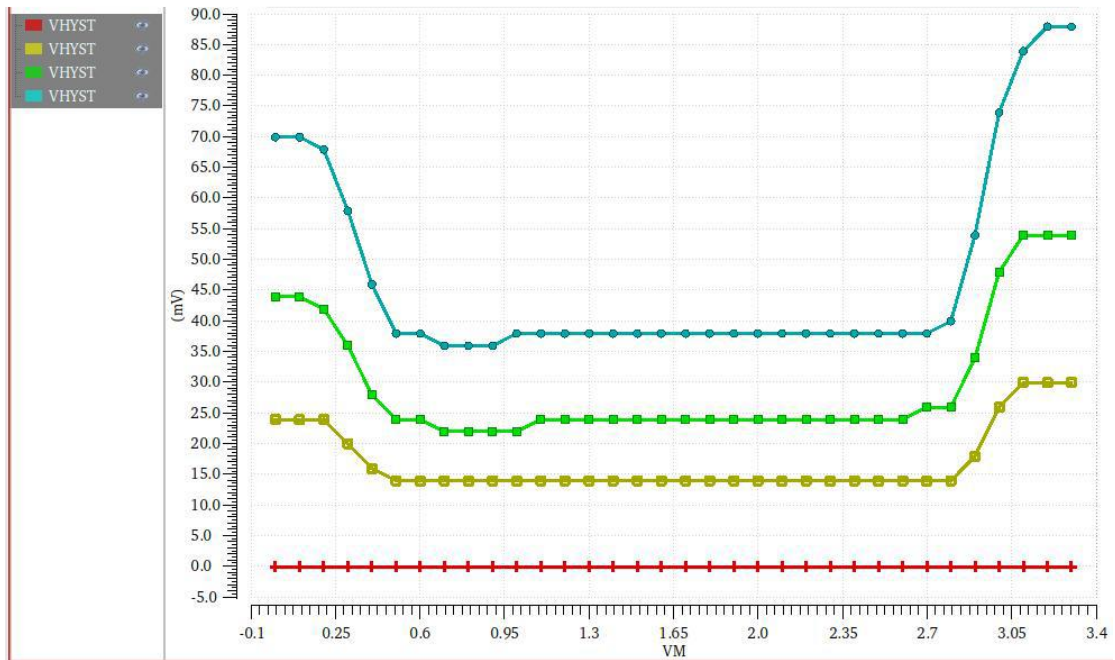

Figure 15 Typical hysteresis vs. Vin level (V<sub>DDA</sub>=3.3V,PMSEL=1)

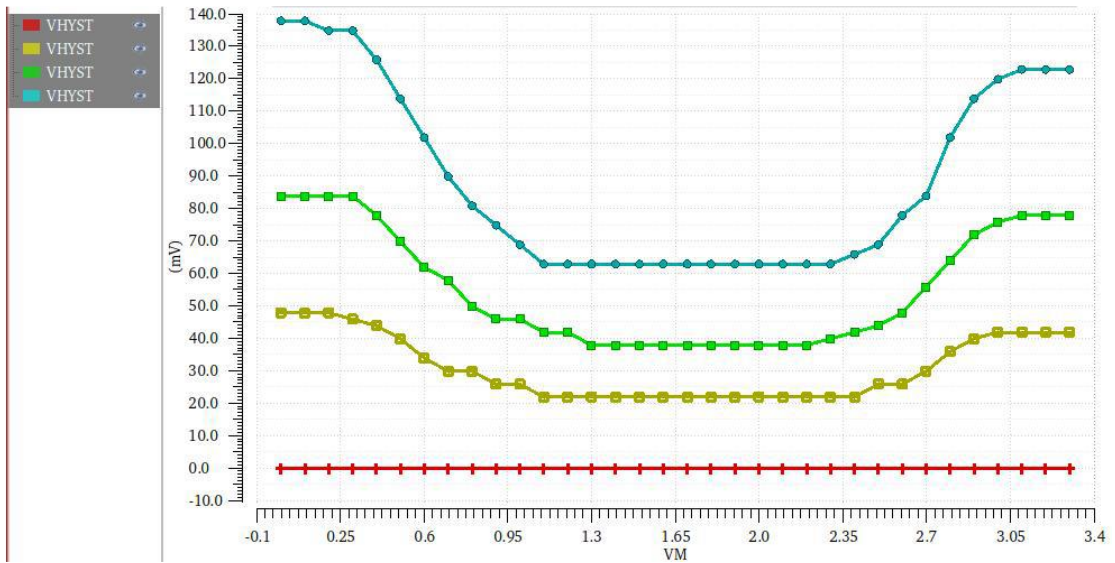

Figure 16 Typical hysteresis vs. Vin level (V<sub>DDA</sub>=5V, PMSEL=0)

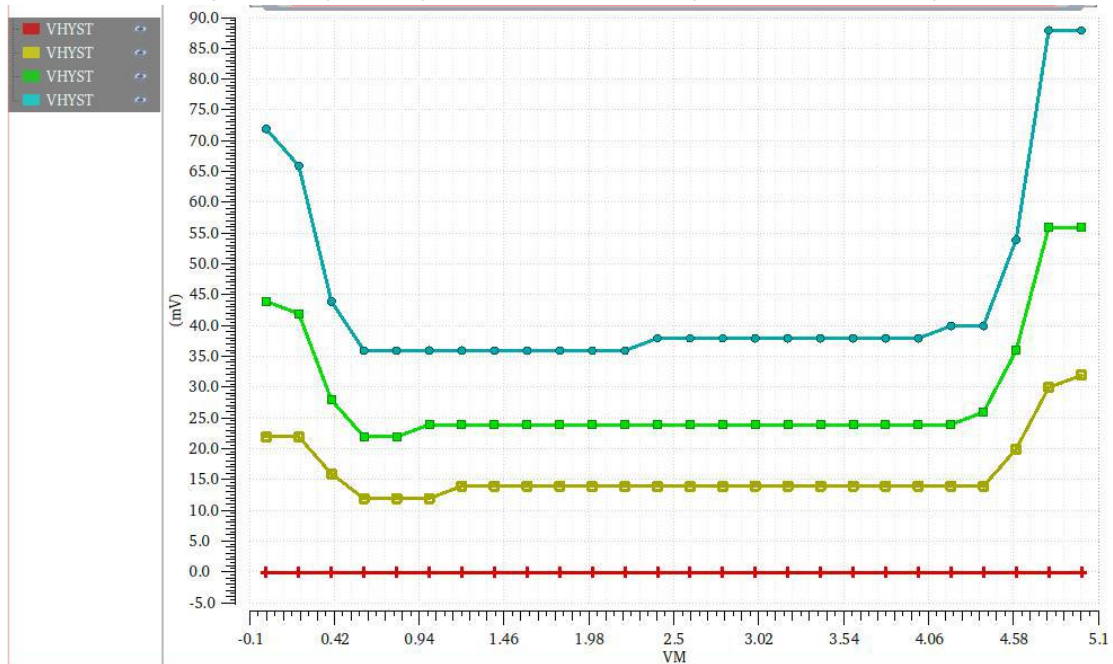
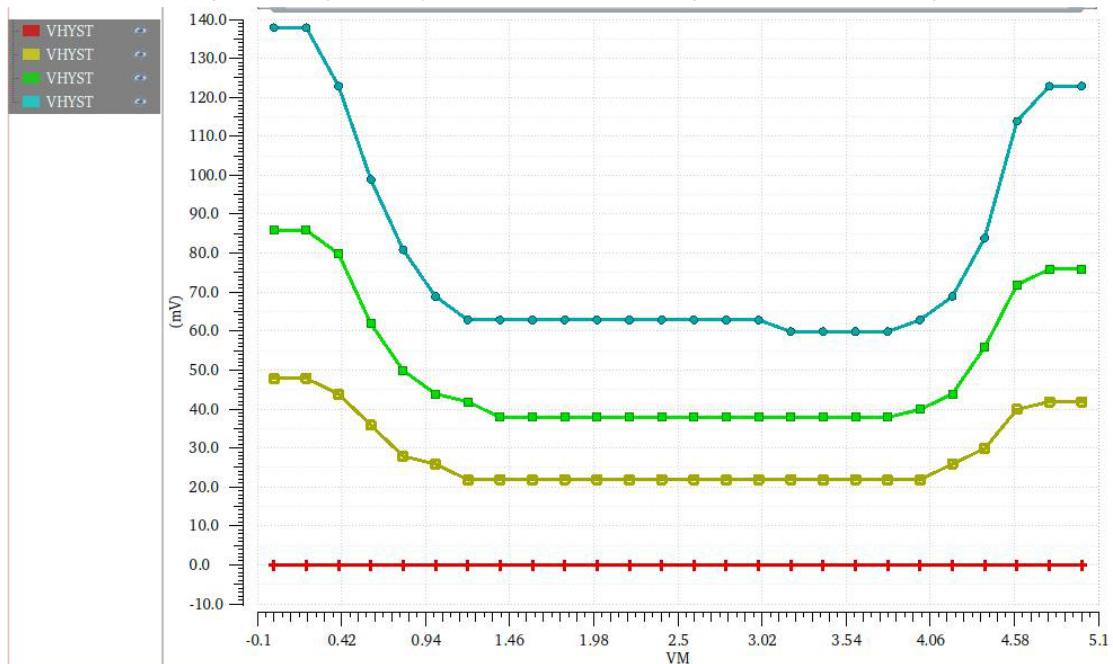

Figure 17 Typical hysteresis vs. Vin level (V<sub>DDA</sub>=5V, PMSEL=1)



## 7.8 Debugging module

### 7.8.1 SWD electrical specifications

#### 7.8.1.1 Electrical specifications for SWD run mode

Table 42 Electrical Specification for SWD Run Mode

Symbol	Parameter	Condition	Operation Modes						Unit
			3.3V IO			5V IO			
			Minimum value	Typical value	Maximum value	Minimum value	Typical value	Maximum value	
$f_{\text{SWCLK}}$	SWD clock operating frequency	-	-	-	25	-	-	25	MHz
$t_{\text{SWCLK}}$	SWD clock cycle	-	$1/f_{\text{SWDCLK}}$	-	-	$1/f_{\text{SWDCLK}}$	-	-	
$t_{\text{r(SWCLK)}}$ $t_{\text{f(SWCLK)}}$	SWD clock rise and fall time	-	-	-	1	-	-	1	
$t_{\text{cpw(SWCLK)}}$	SWCLK clock pulse width	-	$t_{\text{SWDCLK}}/2-5$	-	$t_{\text{SWDCLK}}/2+5$	$t_{\text{SWDCLK}}/2-5$	-	$t_{\text{SWDCLK}}/2+5$	
$t_{\text{su(SWCLK)}}$	Before the SWD clock rises, SWDIO input data setup time	-	4	-	-	4	-	-	ns
$t_{\text{h(SWDIO)}}$	After the SWD clock rises, SWDIO input data hold time	-	3	-	-	3	-	-	
$t_{\text{v(SWD)}}$	SWD clock high to SWDIO data valid	-	-	-	38	-	-	28	

Symbol	Parameter	Condition	Operation Modes						Unit
			3.3V IO			5V IO			
			Minimum value	Typical value	Maximum value	Minimum value	Typical value	Maximum value	
$t_{iv(SWD)}$	SWD clock high to SWDIO data invalid	-	0	-	-	0	-	-	
$t_{h-z(SWD)}$	SWD clock high to SWDIO high resistance	-	-	-	38	-	-	28	

### 7.8.1.2 Electrical specifications for SWD high-speed run mode

Table 43 Electrical Specification for SWD High-speed Run Mode

Symbol	Parameter	Condition	High-speed run mode						Unit
			3.3V IO			5V IO			
			Minimum value	Typical value	Maximum value	Minimum value	Typical value	Maximum value	
$f_{SWCLK}$	SWD clock operating frequency	-	-	-	25	-	-	25	MHz
$t_{SWCLK}$	SWD clock cycle	-	$1/f_{SWDCLK}$	-	-	$1/f_{SWDCLK}$	-	-	
$t_{r(SWCLK)}$ $t_{f(SWCLK)}$	SWD clock rise and fall time	-	-	-	1	-	-	1	
$t_{cpw(SWCLK)}$	SWCLK clock pulse width	-	$t_{SWDCLK}/2-5$	-	$t_{SWDCLK}/2+5$	$t_{SWDCLK}/2-5$	-	$t_{SWDCLK}/2+5$	ns
$t_{su(SWCLK)}$	Before the SWD clock rises, SWDIO input data setup time	-	4	-	-	4	-	-	



Symbol	Parameter	Condition	High-speed run mode						Unit
			3.3V IO			5V IO			
			Minimum value	Typical value	Maximum value	Minimum value	Typical value	Maximum value	
$t_{h(SWDIO)}$	After the SWD clock rises, SWDIO input data hold time	-	3	-	-	3	-	-	
$t_{v(SWD)}$	SWD clock high to SWDIO data valid	-	-	-	38	-	-	28	
$t_{iv(SWD)}$	SWD clock high to SWDIO data invalid	-	0	-	-	0	-	-	
$t_{h-z(SWD)}$	SWD clock high to SWDIO high resistance	-	-	-	38	-	-	28	

### 7.8.1.3 Electrical characteristics of SWD VLPR mode

Table 44 Electrical Specification for SWD VLPR Mode

Symbol	Parameter	Condition	VLPR mode						Unit
			3.3V IO			5V IO			
			Minimum value	Typical value	Maximum value	Minimum value	Typical value	Maximum value	
$f_{swclk}$	SWD clock operating frequency	-	-	-	10	-	-	10	MHz
$t_{swclk}$	SWD clock cycle	-	$1/f_{swdclk}$	-	-	$1/f_{swdclk}$	-	-	
$t_{r(SWCLK)}$ $t_{f(SWCLK)}$	SWD clock rise and fall time	-	-	-	1	-	-	1	ns
$t_{cpw(SWCLK)}$	SWCLK clock pulse width	-	$t_{swdclk}/2-5$	-	$t_{swdclk}/2+5$	$t_{swdclk}/2-5$	-	$t_{swdclk}/2+5$	

Symbol	Parameter	Condition	VLPR mode						Unit
			3.3V IO			5V IO			
			Minimum value	Typical value	Maximum value	Minimum value	Typical value	Maximum value	
$t_{su(SWCLK)}$	Before the SWD clock rises, SWDIO input data setup time	-	16	-	-	16	-	-	
$t_{h(SWDIO)}$	After the SWD clock rises, SWDIO input data hold time	-	10	-	-	10	-	-	
$t_{v(SWD)}$	SWD clock high to SWDIO data valid	-	-	-	77	-	-	70	
$t_{iv(SWD)}$	SWD clock high to SWDIO data invalid	-	0	-	-	0	-	-	
$t_{h-Z(SWD)}$	SWD clock high to SWDIO high resistance	-	-	-	77	-	-	70	

Figure 18 SWD Clock Input Time

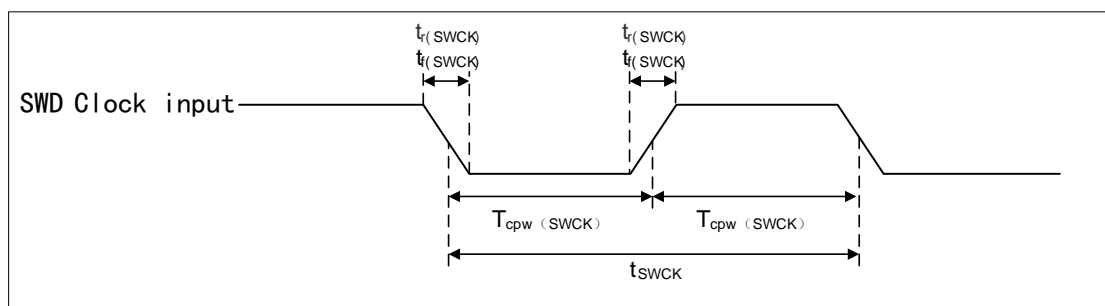
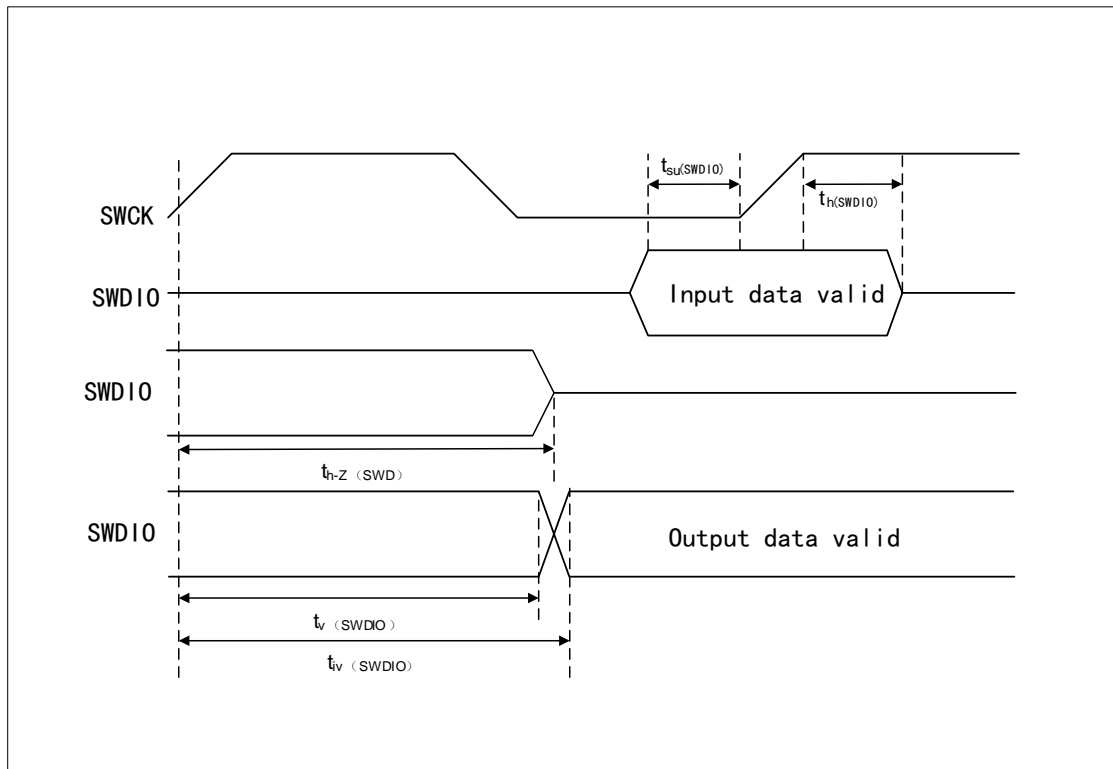

Figure 19 SWD Input/Output Data Time



## 7.8.2 Electrical characteristics of JTAG

### 7.8.2.1 Electrical characteristics of JTAG run mode

Table 45 Electrical Characteristics of JTAG Run Mode

Symbol	Parameter	Condition	Operation Modes						Unit
			3.3V IO			5V IO			
			Minimum value	Typical value	Maximum value	Minimum value	Typical value	Maximum value	
$f_{TCLK}$	TCLK operating frequency	Boundary scan	-	-	20	-	-	20	MHz
		JTAG	-	-	20	-	-	20	
$t_{cpw(TCLK)}$	TCLK clock pulse width	Boundary scan	$t_{TCLK}/2-5$	-	$t_{TCLK}/2+5$	$t_{TCLK}/2-5$	-	$t_{TCLK}/2+5$	ns
		JTAG							
$t_{TCLK}$	TCLK cycle	-	$1/f_{TCLK}$	-	-	$1/f_{TCLK}$	-	-	
$t_{r(TCLK)}$ $t_{f(TCLK)}$	TCLK rise and fall time	-	-	-	1	-	-	1	
$t_{v(BSO)}$	TCLK low to boundary scan output data valid	-	-	-	32	-	-	28	
$t_{iv(BSO)}$	TCLK low to boundary scan output data invalid	-	0	-	-	0	-	-	
$t_{v(TDO)}$	TCLK low to TDO data valid	-	-	-	32	-	-	28	
$t_{iv(TDO)}$	TCLK low to TDO data invalid	-	0	-	-	0	-	-	

Symbol	Parameter	Condition	Operation Modes						Unit
			3.3V IO			5V IO			
			Minimum value	Typical value	Maximum value	Minimum value	Typical value	Maximum value	
$t_{su(BSI)}$	Boundary scan input data setup time	TCLK rises	5	-	-	5	-	-	
$t_{h(BSI)}$	Boundary scan input data hold time	After TCLK rises	5	-	-	5	-	-	
$t_{h-Z(BS)}$	Output high resistance	TCLK is lower than boundary scan	-	-	32	-	-	28	
$t_{h-Z(TDO)}$	Output high resistance	When TCLK is lower than TDO	-	-	32	-	-	28	
$t_{su(TTI)}$	TMS and TDI input data setup time	TCLK rises	3	-	-	3	-	-	
$t_{h(TTI)}$	TMS and TDI input data hold time	After TCLK rises	2	-	-	2	-	-	

### 7.8.2.2 Electrical characteristics of JTAG high-speed run mode

Table 46 Electrical Characteristics of JTAG High-speed Run Mode

Symbol	Parameter	Condition	High-speed run mode						Unit
			3.3V IO			5V IO			
			Minimum value	Typical value	Maximum value	Minimum value	Typical value	Maximum value	
$f_{TCLK}$	TCLK operating frequency	Boundary scan	-	-	20	-	-	20	MHz
		JTAG	-	-	20	-	-	20	
$t_{cpw(TCLK)}$	TCLK clock pulse width	Boundary scan	$t_{TCLK}/2-5$	-	$t_{TCLK}/2+5$	$t_{TCLK}/2-5$	-	$t_{TCLK}/2+5$	ns
		JTAG							

Symbol	Parameter	Condition	High-speed run mode						Unit
			3.3V IO			5V IO			
			Minimum value	Typical value	Maximum value	Minimum value	Typical value	Maximum value	
$t_{TCLK}$	TCLK cycle	-	$1/f_{TCLK}$	-	-	$1/f_{TCLK}$	-	-	
$t_{r(TCLK)}$ $t_{f(TCLK)}$	TCLK rise and fall time	-	-	-	1	-	-	1	
$t_{v(BSO)}$	TCLK low to boundary scan output data valid	-	-	-	32	-	-	28	
$t_{iv(BSO)}$	TCLK low to boundary scan output data invalid	-	0	-	-	0	-	-	
$t_{v(TDO)}$	TCLK low to TDO data valid	-	-	-	32	-	-	28	
$t_{iv(TDO)}$	TCLK low to TDO data invalid	-	0	-	-	0	-	-	
$t_{su(BSI)}$	Before TCLK rises, boundary scan input data setup time	-	5	-	-	5	-	-	
$t_{h(BSI)}$	After TCLK rises, boundary scan input data hold time	-	5	-	-	5	-	-	

Symbol	Parameter	Condition	High-speed run mode						Unit
			3.3V IO			5V IO			
			Minimum value	Typical value	Maximum value	Minimum value	Typical value	Maximum value	
$t_{h-Z(BS)}$	TCLK falling edge to boundary scan output high resistance	-	-	-	32	-	-	28	
$t_{h-Z(TDO)}$	TCLK falling edge to TDO high resistance	-	-	-	32	-	-	28	
$t_{su(TTI)}$	Before TCLK rises, TMS and TDI input data setup time	-	3	-	-	3	-	-	
$t_h(TTI)$	After TCLK rises, TMS and TDI input data hold time	-	2	-	-	2	-	-	

### 7.8.2.3 Electrical characteristics of TAG VLPR mode

Table 47 Electrical Characteristics of JTAG VLPR Mode

Symbol	Parameter	Condition	VLPR mode						Unit
			3.3V IO			5V IO			
			Minimum value	Typical value	Maximum value	Minimum value	Typical value	Maximum value	
$f_{TCLK}$	TCLK operating frequency	Boundary scan	-	-	10	-	-	10	MHz
		JTAG	-	-	10	-	-	10	
$t_{cpw(TCLK)}$	TCLK clock pulse width	Boundary scan	$t_{TCLK}/2-5$	-	$t_{TCLK}/2+5$	$t_{TCLK}/2-5$	-	$t_{TCLK}/2-5$	ns
		JTAG							

Symbol	Parameter	Condition	VLPR mode						Unit
			3.3V IO			5V IO			
			Minimum value	Typical value	Maximum value	Minimum value	Typical value	Maximum value	
$t_{TCLK}$	TCLK cycle	-	$1/f_{TCLK}$	-	-	$1/f_{TCLK}$	-	$1/f_{TCLK}$	
$t_{r(TCLK)}$ $t_{f(TCLK)}$	TCLK rise and fall time	-	-	-	1	-	-	1	
$t_{v(BSO)}$	TCLK low to boundary scan output data valid	-	-	-	80	-	-	80	
$t_{iv(BSO)}$	TCLK low to boundary scan output data invalid	-	0	-	-	0	-	-	
$t_{v(TDO)}$	TCLK low to TDO data valid	-	-	-	80	-	-	80	
$t_{iv(TDO)}$	TCLK low to TDO data invalid	-	0	-	-	0	-	-	
$t_{su(BSI)}$	Before TCLK rises, boundary scan input data setup time		15	-	-	15	-	-	
$t_{h(BSI)}$	After TCLK rises, boundary scan input data hold time		8	-	-	8	-	-	



Symbol	Parameter	Condition	VLPR mode						Unit
			3.3V IO			5V IO			
			Minimum value	Typical value	Maximum value	Minimum value	Typical value	Maximum value	
$t_{h-Z(BS)}$	TCLK falling edge to boundary scan output high resistance		-	-	80	-	-	80	
$t_{h-Z(TDO)}$	TCLK falling edge to TDO high resistance		-	-	80	-	-	80	
$t_{su(TTI)}$	Before TCLK rises, TMS and TDI input data setup time		15	-	-	15	-	-	
$t_h(TTI)$	After TCLK rises, TMS and TDI input data hold time		8	-	-	8	-	-	

Figure 20 TCLK Input Timing

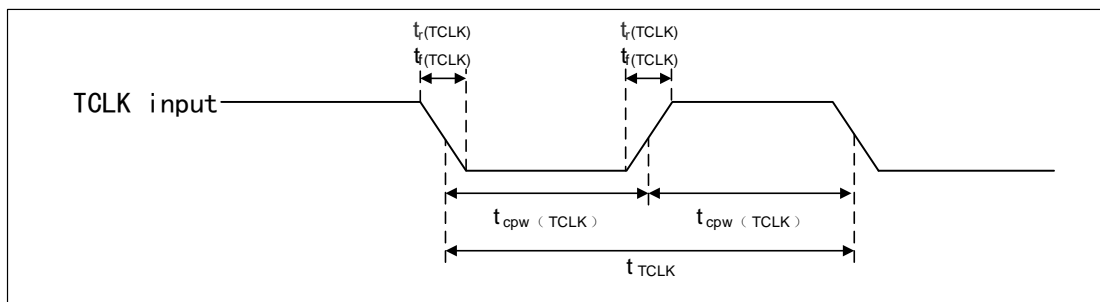

Figure 21 JTAG Boundary Scan Timing

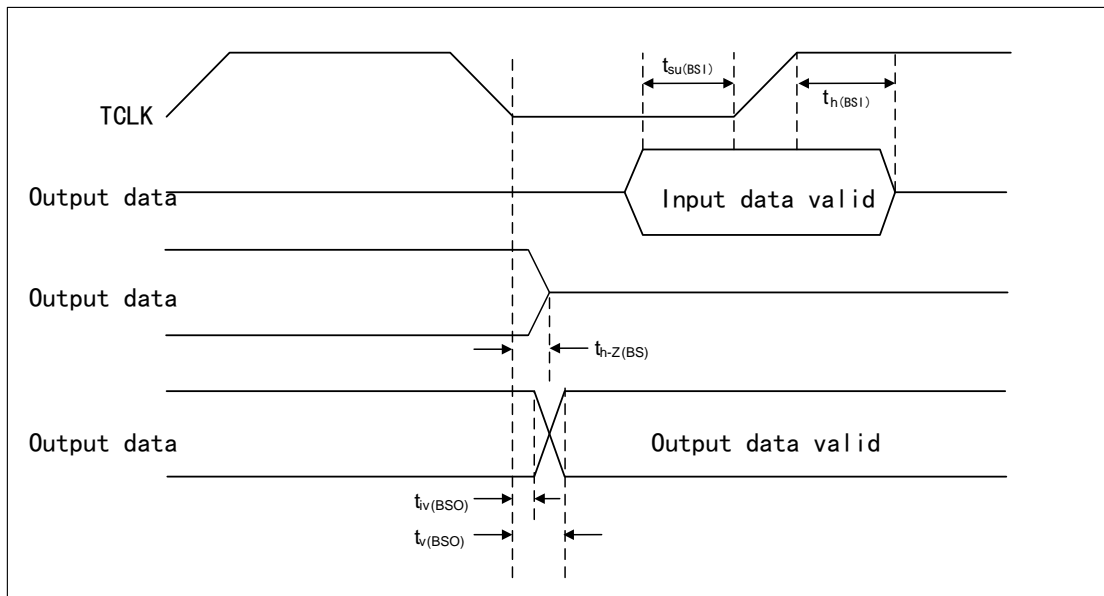
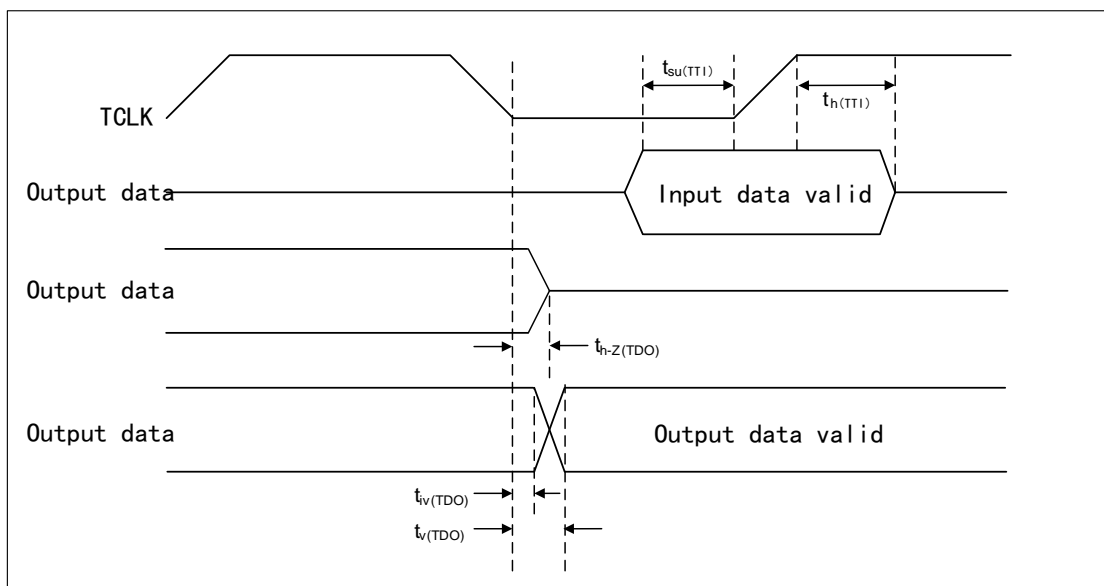

Figure 22 TDO Timing



## 7.9 Temperature characteristics

### 7.9.1 General precautions for specifications at maximum junction temperature

Calculation of chip junction temperature  $T_J$  can be obtained from the following equation:

$$T_J = (R_{\theta JA} \times P_D) + T_A$$

Where:  $R_{\theta JA}$  represents the thermal resistance of the joint to the environment ( $^{\circ}\text{C}/\text{W}$ ),  $P_D$  represents the power dissipation of the package (W), and  $T_A$  represents the ambient temperature of the packaging ( $^{\circ}\text{C}$ ).

The thermal resistance connected to the environment is an industry standard value, and can be used to estimate the temperature characteristics quickly and conveniently. Usually it is determined by two values: the determined of the single-layer boards and the value measured on the double-layer boards. Which value is closer to the application depends on the power consumed by other components on the board. The values on the single-layer boards are applicable to tightly encapsulated printed circuit boards; if the power consumption of the board is low and the components are well separated, the value obtained on the board with an internal plane is more suitable.

When using a radiator, the thermal resistance in the following equation is expressed as the sum of the thermal resistance connected to the shell and the ambient thermal resistance:

$$R_{\theta JA} = R_{\theta CA} + R_{\theta JC}$$

Where:  $R_{\theta JA}$  represents the thermal resistance ( $^{\circ}\text{C}/\text{W}$ ) of the joint to the environment,  $R_{\theta CA}$  represents ambient thermal resistance ( $^{\circ}\text{C}/\text{W}$ ), and  $R_{\theta JC}$  represents the thermal resistance ( $^{\circ}\text{C}/\text{W}$ ) of the joint to the shell.

The value of  $R_{\theta JC}$  is related to the equipment and is not controlled by users. Users can change the instance to the ambient thermal resistance  $R_{\theta CA}$  by controlling the thermal environment. For example, users can change the heat dissipation of the printed circuit board around the equipment, the airflow around the equipment, interface materials, wiring on the printed circuit board, or dimensions of the radiator.

When the radiator is not used, the thermal characterization parameters ( $\psi_{JT}$ ) can be used to determine the junction temperature of the device in the application, and the following equation can be used to measure the center temperature at the top of the package shell:

$$T_J = T_T + (\psi_{JT} \times P_D)$$

Where:  $T_T$  represents the temperature of the thermocouple at the top of the package ( $^{\circ}\text{C}$ ),  $\psi_{JT}$  represents the thermal characterization parameter ( $^{\circ}\text{C}/\text{W}$ ), and  $P_D$  represents the power dissipation of the package (W).

According to the JESD51-2 standard, the temperature characteristic parameters are measured with a No. 40 T-type thermocouple connected to the center of the top of the package with epoxy resin.

Note:

- (1) The thermocouple wire shall be laid flat on the package shell to avoid measurement errors caused by the cooling effect of the thermocouple wires.
- (2) Ensure that the thermocouple junction is located on the package. Place a small amount of epoxy resin on the thermocouple junction and place it on the approximately 1mm wire extending from the junction.

## 7.9.2 Temperature characteristics

Table 48 Temperature Characteristics

Symbol	Parameter	Condition	Package		Unit
			LQFP64	LQFP100	
$R_{\theta JA}^{(1)}$	Thermal resistance, joint to the environment (natural convection)	Single-layer board (1s)	59	51	$^{\circ}\text{C}/\text{W}$
		Double-layer board (1s1p)	44	40	$^{\circ}\text{C}/\text{W}$
		Four-layer board (2s2p)	41	39	$^{\circ}\text{C}/\text{W}$
$R_{\theta JA}^{(1)}$	Thermal resistance, joint to the environment (forced convection, 200 feet/min)	Single-layer board (1s)	48	41	$^{\circ}\text{C}/\text{W}$
		Double-layer board (1s1p)	37	34	$^{\circ}\text{C}/\text{W}$
		Four-layer board (2s2p)	35	33	$^{\circ}\text{C}/\text{W}$
$R_{\theta JC}^{(2)}$	Thermal resistance, joint to the shell	-	11	11	$^{\circ}\text{C}/\text{W}$
$R_{\theta JB}^{(3)}$	Thermal resistance, joint to the board	-	23	24	$^{\circ}\text{C}/\text{W}$
$\psi_{JT}^{(4)}$	Thermal resistance, joint to the top of the package	Natural convection	2	2	$^{\circ}\text{C}/\text{W}$

Notes:

- (1) The size of tube core, thermal resistance of package, thermal resistance of board, ambient temperature, installation position (board) temperature, air flow rate, power consumption on the chip, and power consumption of other components on the board all affect the junction temperature, and the junction temperature is a function of these parameters.
- (2) Indicates the thermal resistance between the mold and the surface of the shell, measured through the cold plate method.

- (3) Indicates the thermal resistance between the chip and the printed circuit board. The temperature of the board is measured on the top surface of the board near the package.
- (4) Thermal characterization parameter, indicating the temperature difference between the junction temperature and the top of the package. When Greek alphabet is not available, this parameter will be expressed as Psi JT.

## 8 Package Information

### 8.1 LQFP100 package information

Figure 23 LQFP100 Package Diagram

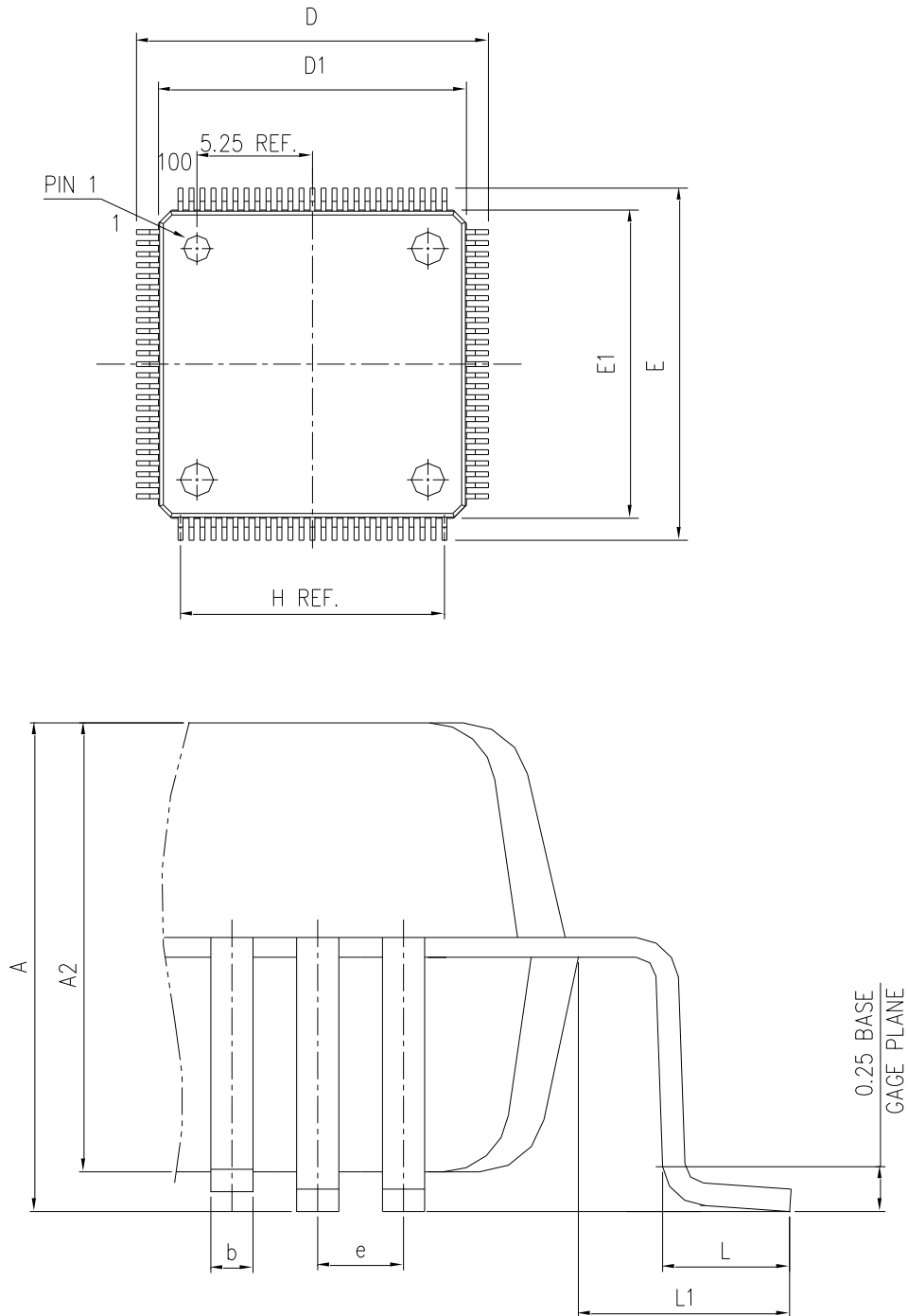

- (1) The figure is not drawn to scale.
- (2) All pins should be soldered to the PCB.

Table 49 LQFP100 Package Data

DIMENSION LIST (FOOTPRINT: 2.00)			
S/N	SYM	DIMENDIONS	REMARKS
1	A	MAX. 1.600	OVERALL HEIGHT
2	A2	1.400±0.050	PKG THICKNESS
3	D	16.000±0.200	LEAD TIP TO TIP
4	D1	14.000±0.100	PKG LENGTH
5	E	16.000±0.200	LEAD TIP TO TIP
6	E1	14.000±0.100	PKG WPTH
7	L	0.600±0.150	FOOT LENGTH
8	L1	1.000 REF	LEAD LENGTH
9	e	0.500 BASE	LEAD PITCH
10	H (REF)	(12.00)	CUM LEAD PITCH
11	b	0.22±0.050	LEAD WIDTH

Note: Dimensions are marked in millimeters.

Figure 24 LQFP100 - 100 Pins, 14 x 14mm Welding Layout Recommendations

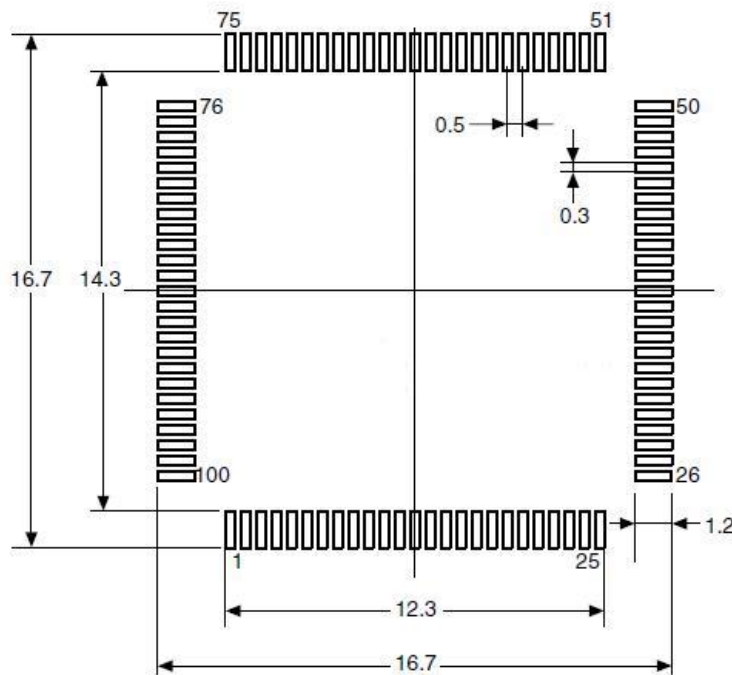

Note: Dimensions are marked in millimeters.

Figure 25 LQFP100 - 100 Pins, 14 x 14mm Diagram

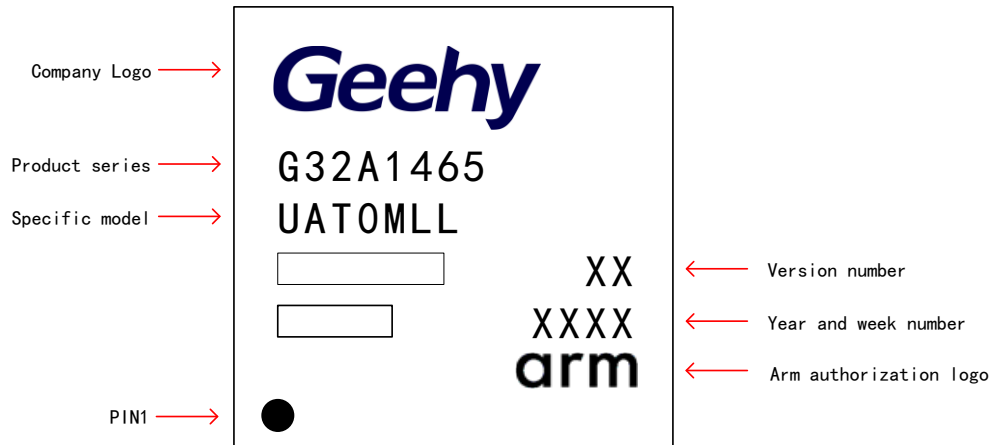



## 8.2 LQFP64 package information

Figure 26 LQFP64 Package Diagram

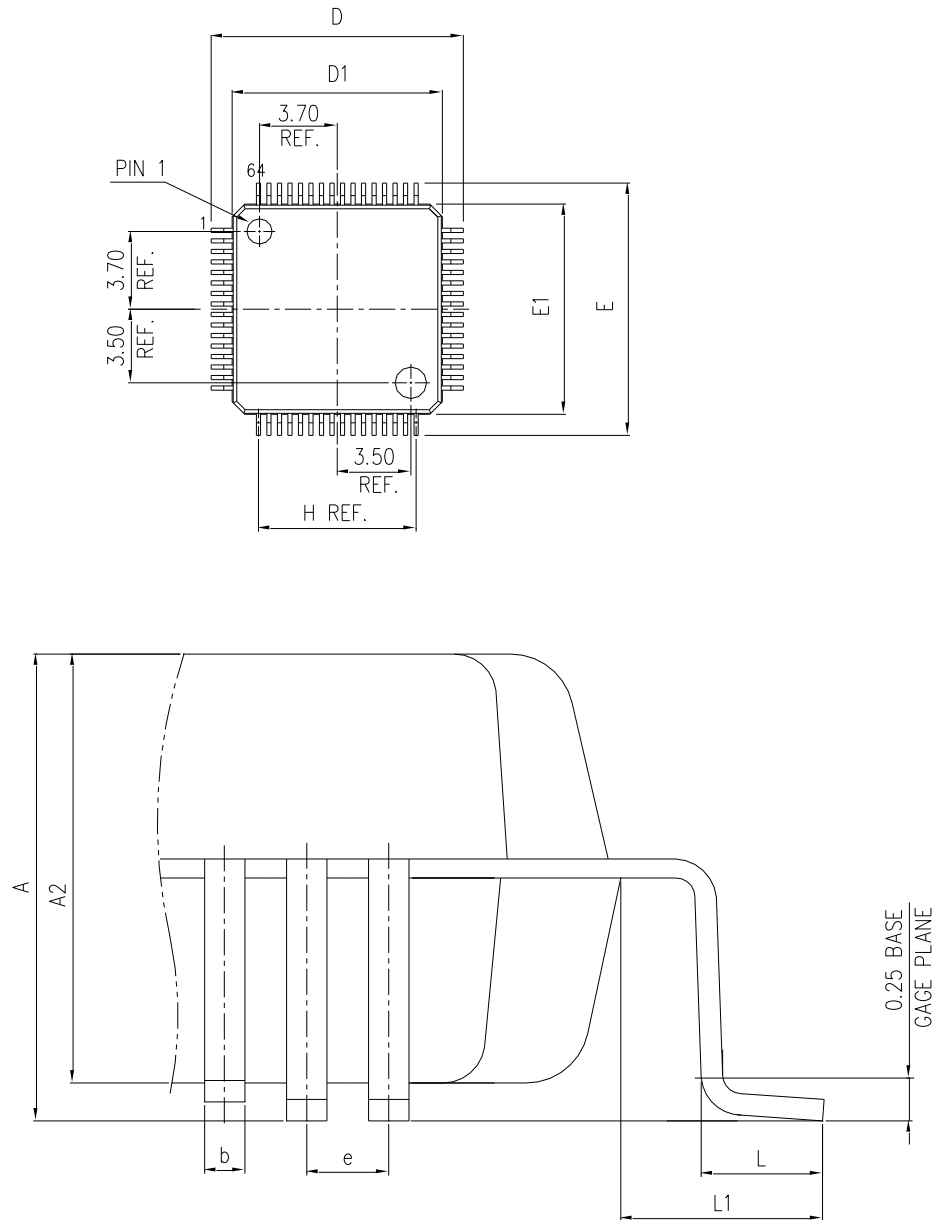

- (1) The figure is not drawn to scale.
- (2) All pins should be soldered to the PCB.

Table 50 LQFP64 Package Data

S/N	SYM	DIMENSIONS	REMARKS
1	A	MAX.1.600	OVERALLHEIGHT
2	A2	1.400±0.050	PKGTHICKNESS
3	D	12.000±0.200	LEADTIPTOTIP
4	D1	10.000±0.100	PKGLENGTH
5	E	12.000±0.200	LEADTIPTOTIP
6	E1	10.000±0.100	PKGWIDTH
7	L	0.600±0.150	FOOTLENGTH
8	L1	1.000REF.	LEADLENGTH
9	e	0.500BASE	LEADPITCH
10	H(REF.)	(7.500)	GUM.LEADPITCH
11	b	0.220±0.050	LEADWIDTH

Note: Dimensions are marked in millimeters.

Figure 27 LQFP64 Welding Layout Recommendations

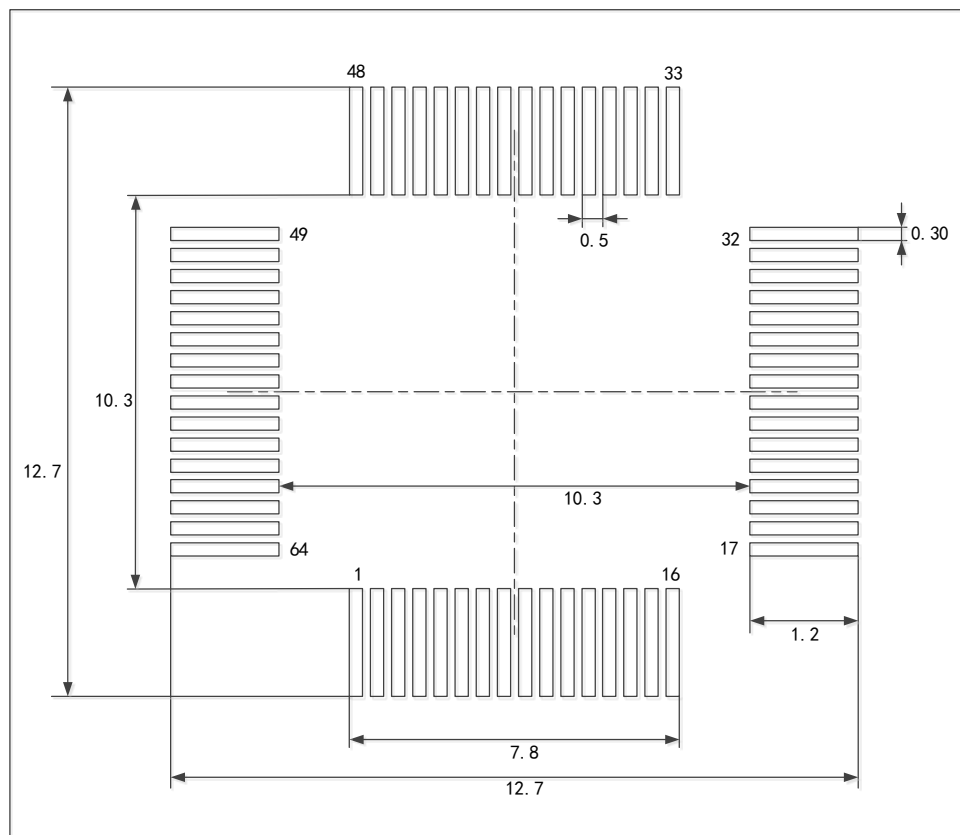

Note: Dimensions are marked in millimeters.

Figure 28 LQFP64 - 64 Pins, 10 x 10mm Diagram

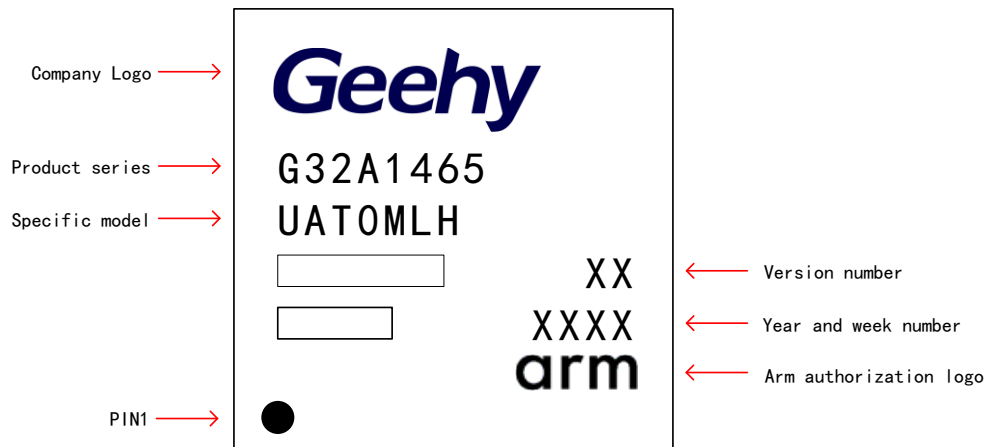

## 9 Packaging Information

### 9.1 Reel Packaging

Figure 29 Reel Packaging Specification Drawing

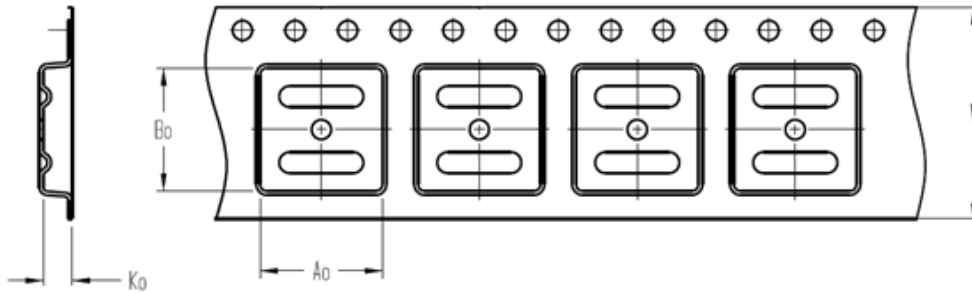

A0	Dimension designed to accommodate the component width
B0	Dimension designed to accommodate the component length
K0	Dimension designed to accommodate the component thickness
W	Overall width of the carrier tape

#### Quadrant Assignments for PIN1 Orientation in Tape

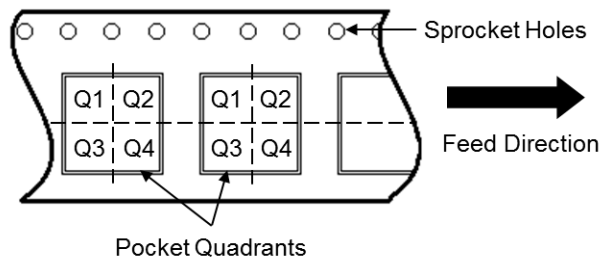

#### Reel Dimensions

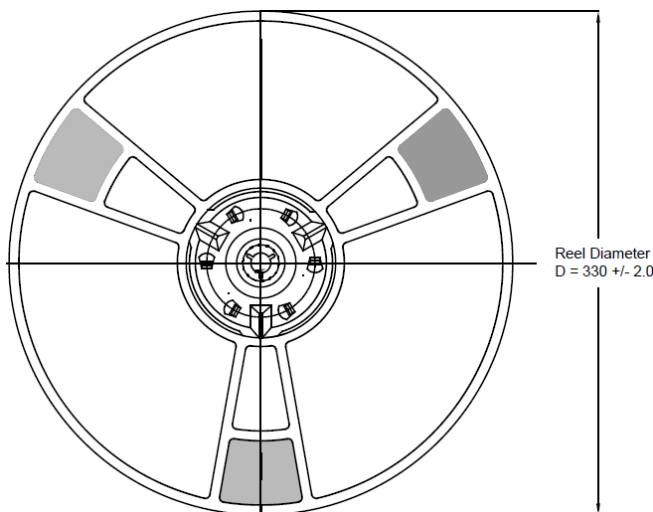

All photos are for reference only, and the appearance is subject to the product.

Table 51 Reel Packaging Parameter Specification Table

Device	Package Type	Pins	SPQ	Reel Diameter (mm)	A0 (mm)	B0 (mm)	K0 (mm)	W (mm)	Pin1 Quadrant
G32A1465UAT0MLHR	LQFP	64	1000	330	12.35	12.35	2.2	24	Q1
G32A1465HAT0MLHR	LQFP	64	1000	330	12.35	12.35	2.2	24	Q1
G32A1465UAT0VLHR	LQFP	64	1000	330	12.35	12.35	2.2	24	Q1
G32A1465HAT0VLHR	LQFP	64	1000	330	12.35	12.35	2.2	24	Q1

## 9.2 Tray packaging

Figure 30 Tray Packaging Diagram

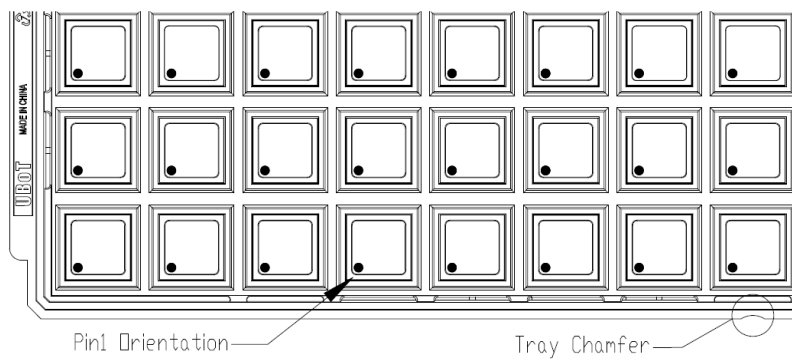

### Tray Dimensions

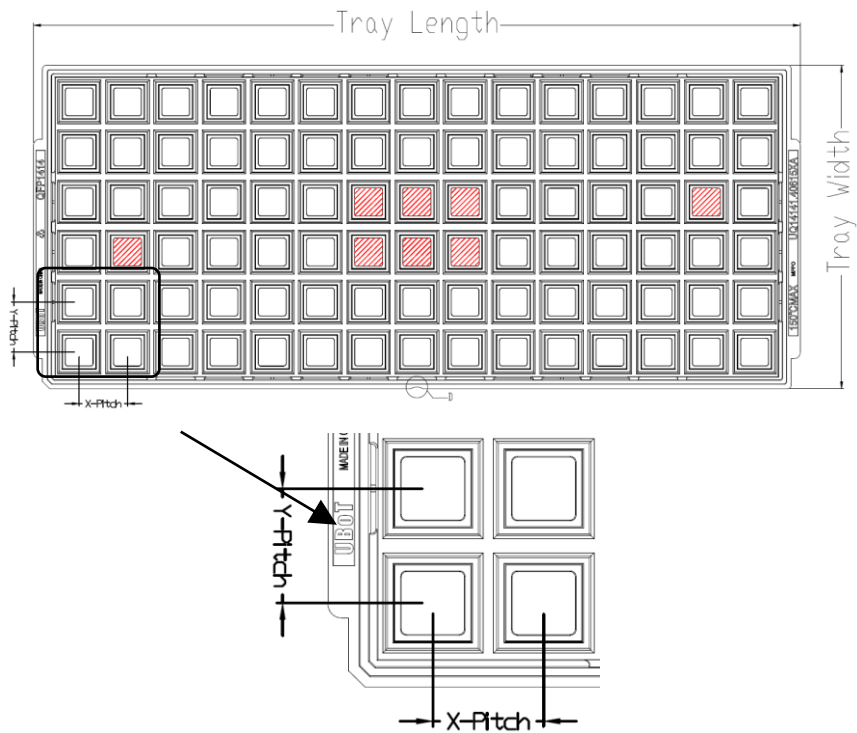

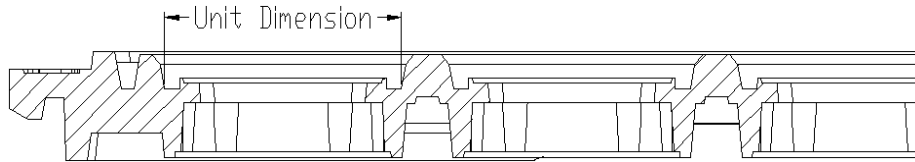

All photos are for reference only, and the appearance is subject to the product

Table 52 Tray Packaging Parameter Specification Table

Device	Package Type	Pins	SPQ	X-Dimension (mm)	Y-Dimension (mm)	X-Pitch (mm)	Y-Pitch (mm)	Tray Length (mm)	Tray Width (mm)
G32A1465UAT0MLLT	LQFP	100	900	16.6	16.6	20.3	21	322.6	135.9
G32A1465HAT0MLLT	LQFP	100	900	16.6	16.6	20.3	21	322.6	135.9
G32A1465UAT0VLLT	LQFP	100	900	16.6	16.6	20.3	21	322.6	135.9
G32A1465HAT0VLLT	LQFP	100	900	16.6	16.6	20.3	21	322.6	135.9
G32A1465UAT0MLHT	LQFP	64	1600	12.3	12.3	15.2	15.7	322.6	135.9
G32A1465HAT0MLHT	LQFP	64	1600	12.3	12.3	15.2	15.7	322.6	135.9
G32A1465UAT0VLHT	LQFP	64	1600	12.3	12.3	15.2	15.7	322.6	135.9
G32A1465HAT0VLHT	LQFP	64	1600	12.3	12.3	15.2	15.7	322.6	135.9

# 10 Ordering Information

Figure 31 Product Information Naming Rules

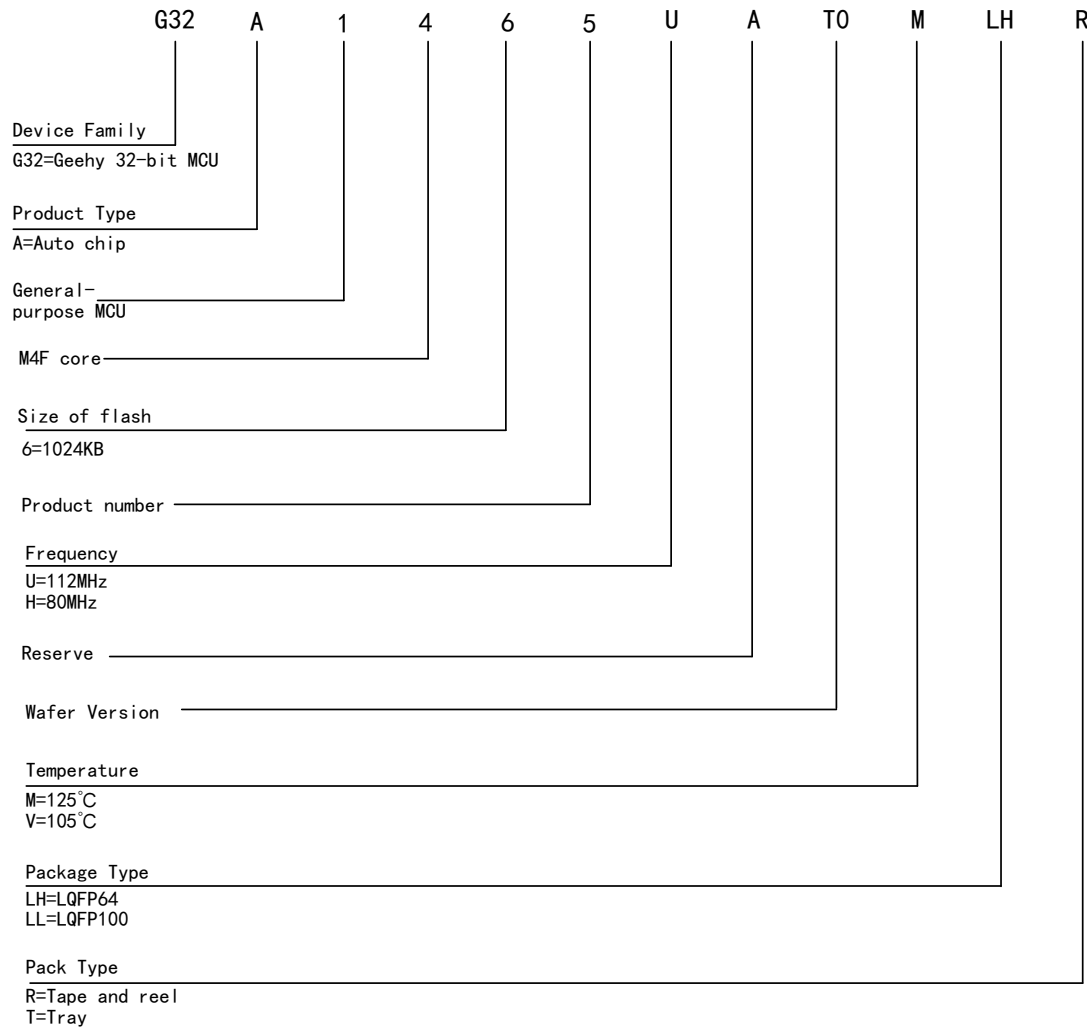

Table 53 Ordering Information Table

Order Code	Dominant frequency	Flash (KB)	SRAM (KB)	EEPROM (KB)	Package	SPQ	Temperature range
G32A1465UAT0MLHT	112MHz	1024	128	4	LQFP64	1600	-40°C~125°C
G32A1465HAT0MLHT	80MHz	1024	128	4	LQFP64	1600	-40°C~125°C
G32A1465UAT0MLHR	112MHz	1024	128	4	LQFP64	1000	-40°C~125°C
G32A1465HAT0MLHR	80MHz	1024	128	4	LQFP64	1000	-40°C~125°C
G32A1465UAT0VLHT	112MHz	1024	128	4	LQFP64	1600	-40°C~105°C
G32A1465HAT0VLHT	80MHz	1024	128	4	LQFP64	1600	-40°C~105°C
G32A1465UAT0VLHR	112MHz	1024	128	4	LQFP64	1000	-40°C~105°C
G32A1465HAT0VLHR	80MHz	1024	128	4	LQFP64	1000	-40°C~105°C

Order Code	Dominant frequency	Flash (KB)	SRAM (KB)	EEPROM (KB)	Package	SPQ	Temperature range
G32A1465UAT0MLLT	112MHz	1024	128	4	LQFP100	900	-40°C~125°C
G32A1465HAT0MLLT	80MHz	1024	128	4	LQFP100	900	-40°C~125°C
G32A1465UAT0VLLT	112MHz	1024	128	4	LQFP100	900	-40°C~105°C
G32A1465HAT0VLLT	80MHz	1024	128	4	LQFP100	900	-40°C~105°C

Note: SPQ: Smallest Packaging Quantity.



# 11 Commonly Used Function Module Denomination

Table 54 Commonly Used Function Module Denomination

Full name	Abbreviation
Reset management unit	RMU
Clock management unit	CMU
Reset and clock management	RCM
External Interrupt	EINT
General-purpose IO	GPIO
Multiplexing IO	AFIO
Wake-up controller	WUPT
Buzzer	BUZZER
Independent watchdog timer	IWDT
Window watchdog timer	WWDT
Timer	TMR
CRC controller	CRC
Power Management Unit	PMU
DMA controller	DMA
Analog-to-digital converter	ADC
Real-time clock	RTC
External memory controller	EMMC
Controller local area network	CAN
I2C Interface	I2C
Serial peripheral interface	SPI
Universal asynchronous transmitter receiver	UART
Universal synchronous and asynchronous transmitter receiver	USART
Flash interface control unit	FMC
Secure digital input/output	SDIO
Digital camera interface	DCI

## 12 Revision History

Table 55 Document Revision History

Date	Version	Revision History
April 2024	V0.1	New
June 2024	V0.2	Add data
July 2024	V1.0	Modify electrical characteristics
August 2024	V1.1	(1) Modify product features, product information, and pin functions
October, 2024	V1.2	Add flash storage time and erase cycle

# Statement

This document is formulated and published by Geehy Semiconductor Co., Ltd. (hereinafter referred to as “Geehy”). The contents in this document are protected by laws and regulations of trademark, copyright and software copyright. Geehy reserves the right to make corrections and modifications to this document at any time. Read this document carefully before using Geehy products. Once you use the Geehy product, it means that you (hereinafter referred to as the “users”) have known and accepted all the contents of this document. Users shall use the Geehy product in accordance with relevant laws and regulations and the requirements of this document.

## 1. Ownership

This document can only be used in connection with the corresponding chip products or software products provided by Geehy. Without the prior permission of Geehy, no unit or individual may copy, transcribe, modify, edit or disseminate all or part of the contents of this document for any reason or in any form.

The “极海” or “Geehy” words or graphics with “®” or “™” in this document are trademarks of Geehy. Other product or service names displayed on Geehy products are the property of their respective owners.

## 2. No Intellectual Property License

Geehy owns all rights, ownership and intellectual property rights involved in this document.

Geehy shall not be deemed to grant the license or right of any intellectual property to users explicitly or implicitly due to the sale or distribution of Geehy products or this document.

If any third party’s products, services or intellectual property are involved in this document, it shall not be deemed that Geehy authorizes users to use the aforesaid third party’s products, services or intellectual property. Any information regarding the application of the product, Geehy hereby disclaims any and all warranties and liabilities of any kind, including without limitation warranties of

non-infringement of intellectual property rights of any third party, unless otherwise agreed in sales order or sales contract.

### 3. Version Update

Users can obtain the latest document of the corresponding models when ordering Geehy products.

If the contents in this document are inconsistent with Geehy products, the agreement in the sales order or the sales contract shall prevail.

### 4. Information Reliability

The relevant data in this document are obtained from batch test by Geehy Laboratory or cooperative third-party testing organization. However, clerical errors in correction or errors caused by differences in testing environment may occur inevitably. Therefore, users should understand that Geehy does not bear any responsibility for such errors that may occur in this document. The relevant data in this document are only used to guide users as performance parameter reference and do not constitute Geehy's guarantee for any product performance.

Users shall select appropriate Geehy products according to their own needs, and effectively verify and test the applicability of Geehy products to confirm that Geehy products meet their own needs, corresponding standards, safety or other reliability requirements. If losses are caused to users due to user's failure to fully verify and test Geehy products, Geehy will not bear any responsibility.

### 5. Legality

USERS SHALL ABIDE BY ALL APPLICABLE LOCAL LAWS AND REGULATIONS WHEN USING THIS DOCUMENT AND THE MATCHING GEEHY PRODUCTS. USERS SHALL UNDERSTAND THAT THE PRODUCTS MAY BE RESTRICTED BY THE EXPORT, RE-EXPORT OR OTHER LAWS OF THE COUNTRIES OF THE PRODUCTS SUPPLIERS, GEEHY, GEEHY DISTRIBUTORS AND USERS. USERS (ON BEHALF OR ITSELF, SUBSIDIARIES AND AFFILIATED ENTERPRISES) SHALL AGREE AND PROMISE TO ABIDE BY ALL APPLICABLE LAWS AND REGULATIONS ON

THE EXPORT AND RE-EXPORT OF GEEHY PRODUCTS AND/OR TECHNOLOGIES AND DIRECT PRODUCTS.

#### 6. Disclaimer of Warranty

THIS DOCUMENT IS PROVIDED BY GEEHY "AS IS" AND THERE IS NO WARRANTY OF ANY KIND, EITHER EXPRESSED OR IMPLIED, INCLUDING, BUT NOT LIMITED TO, THE WARRANTIES OF MERCHANTABILITY AND FITNESS FOR A PARTICULAR PURPOSE, TO THE EXTENT PERMITTED BY APPLICABLE LAW.

GEEHY'S PRODUCTS ARE NOT DESIGNED, AUTHORIZED, OR WARRANTED FOR USE AS CRITICAL COMPONENTS IN MILITARY, LIFE-SUPPORT, POLLUTION CONTROL, OR HAZARDOUS SUBSTANCES MANAGEMENT SYSTEMS, NOR WHERE FAILURE COULD RESULT IN INJURY, DEATH, PROPERTY OR ENVIRONMENTAL DAMAGE.

IF THE PRODUCT IS NOT LABELED AS "AUTOMOTIVE GRADE," IT SHOULD NOT BE CONSIDERED SUITABLE FOR AUTOMOTIVE APPLICATIONS. GEEHY ASSUMES NO LIABILITY FOR THE USE BEYOND ITS SPECIFICATIONS OR GUIDELINES.

THE USER SHOULD ENSURE THAT THE APPLICATION OF THE PRODUCTS COMPLIES WITH ALL RELEVANT STANDARDS, INCLUDING BUT NOT LIMITED TO SAFETY, INFORMATION SECURITY, AND ENVIRONMENTAL REQUIREMENTS. THE USER ASSUMES FULL RESPONSIBILITY FOR THE SELECTION AND USE OF GEEHY PRODUCTS. GEEHY WILL BEAR NO RESPONSIBILITY FOR ANY DISPUTES ARISING FROM THE SUBSEQUENT DESIGN OR USE BY USERS.

#### 7. Limitation of Liability

IN NO EVENT, UNLESS REQUIRED BY APPLICABLE LAW OR AGREED TO IN WRITING WILL GEEHY OR ANY OTHER PARTY WHO PROVIDES THE DOCUMENT AND PRODUCTS "AS IS", BE LIABLE FOR DAMAGES, INCLUDING ANY GENERAL, SPECIAL, DIRECT, INCIDENTAL OR CONSEQUENTIAL DAMAGES ARISING OUT OF THE USE OR INABILITY TO USE THE DOCUMENT AND PRODUCTS (INCLUDING BUT NOT LIMITED TO

LOSSES OF DATA OR DATA BEING RENDERED INACCURATE OR LOSSES SUSTAINED BY USERS OR THIRD PARTIES). THIS COVERS POTENTIAL DAMAGES TO PERSONAL SAFETY, PROPERTY, OR THE ENVIRONMENT, FOR WHICH GEEHY WILL NOT BE RESPONSIBLE.

#### 8. Scope of Application

The information in this document replaces the information provided in all previous versions of the document.

© 2024 Geehy Semiconductor Co., Ltd. - All Rights Reserved