



3A, 40V Asynchronous Step-Down Converter

DESCRIPTION

The G5214A is a current mode monolithic buck switching regulator. Operating with an input range of 4.7-40V, the G5214A delivers 3A of continuous output current with an integrated high side N-Channel MOSFET. At light loads, G5214A operates in low frequency to maintain high efficiency and low output voltage ripple. Current mode control provides tight load transient response and cycle-by-cycle current limiting.

The G5214A guarantees robustness with input under-voltage lockout, start-up current run-away protection, output short protection and thermal protection.

The G5214A is available in SOP8 and ESOP8 packages, which provides a compact solution with minimal external components.

FEATURES

- 4.7V to 40V operating input range 3A output current
- Up to 92% efficiency
- High efficiency (>78%) at light load
- Internal soft-start
- Adjustable switch frequency
- Input under-voltage lockout
- Start-up current run-away protection
- Output short protection
- Thermal protection
- Available in ESOP8 packages

APPLICATIONS

- Distributed Power Systems
- Networking Systems
- FPGA, DSP, ASIC Power Supplies
- Green Electronics/ Appliances
- Notebook Computers

TYPICAL APPLICATION

Step Down Regulators

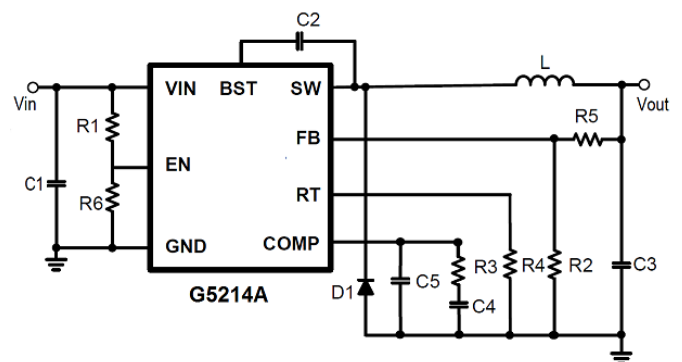

PIN CONFIGURATION

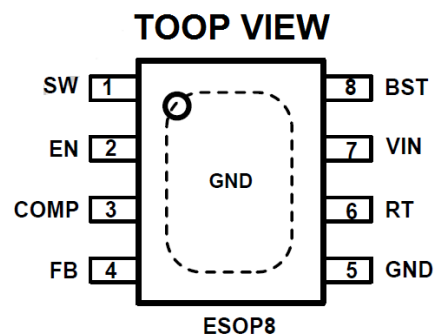

**PIN DESCRIPTION**

Pin Name	Pin NO.	Pin Description
SW	1	SW is the switching node that supplies power to the output. Connect the output LC filter from SW to the output load.
EN	2	Drive EN pin high to turn on the regulator and low to turn off the regulator.
COMP	3	Compensation pin. Comp is used to compensate the regulation control loop. Connect a series RC network from COMP to GND to compensate the regulation control loop. One ceramic cap such as several tens pF is usually connected from COMP to GND to decouple the voltage noise.
FB	4	Output feedback pin. FB senses the output voltage and is regulated by the control loop to FB reference voltage 0.8V. Connect a resistive divider at FB.
GND	5/EP	Ground.
RT	6	Voltage at the RT pin is regulated at 1.2V. Switch frequency of the regulator can be adjusted by connecting a resistor at the RT pin to ground.
VIN	7	Input voltage pin. VIN supplies power to the IC. Connect a 4.7V to 40V supply to VIN and bypass VIN to GND with a suitably large capacitor to eliminate noise on the input pin to the IC.
BST	8	Bootstrap pin for top switch. A 0.1uF or larger capacitor should be connected between this pin and SW pin to supply current to the top switch and top switch driver.

Absolute Maximum Ratings ¹

Parameter	Value	Unit
VIN ,EN input pin voltage	-0.3 ~45	V
SW PIN	0.3V(-5V for 10ns) to 45V(50V for 10ns)	V
BST PIN	SW-0.3 TO SW+5	V
ALL OTHER PINS	-0.3 ~ 6	V
Operating Ambient Temperature	-40 ~ +85	°C
Maximum Junction Temperature ²	150	°C
Storage Temperature	-65 ~ 150	°C
Package Thermal Resistance (Junction to Ambient)	52	°C/W
Lead temperature	260	°C
RECOMMENDED OPERATING CONDITIONS ³		
Input Voltage Vin	4.7 TO 40	V
Output voltage vOUT	0.8 TO DMAX X VIN	V

Note:

1) Exceeding these ratings may damage the device. These stress ratings do not imply function operation of the device at any other conditions beyond those indicated under RECOMMEND OPERATION CONDITIONS.



2) The G5214A includes thermal protection that is intended to protect the device in overload conditions. Continuous operation over the specified absolute maximum operating junction temperature may damage the device.

3) The device is not guaranteed to function outside of its operating conditions.

Electrical Characteristics (VIN=12V,TA=25°C,UNLESS OTHERWISE STATED)

Parameter	Symbol	Test Condition	Min.	Typ.	Max.	Unit
VIN UVLO Threshold	VIN_MIN	VIN FALLING	3.5	3.8	4.1	V
VIN UVLO Hysteresis ⁴	VIN_MIN-HYST	VIN rising		400		mV
Shutdown Supply Current	ISD	VEN=0V		1.6	5	uA
Supply Current	IQ	VEN=5V,VFB=1.2V		65	100	uA
Feedback Voltage	VFB	4.7V<V _{VIN} <40V	0.78	0.8	0.82	V
Top Switch Resistance	RDSON			63	78	mΩ
Top Switch Leakage Current	ILEAK_TOP	VIN=40V,VEN=0V,V _{SW} =0V			1	uA
Top Switch Current Limit ⁴	ILIM_TOP	MINIMUM DUTY CYCLE	3.6	4.5		A
Error Amp Min Source Current		FB=0.4V		15		uA
Error amp min sink current		FB=1.2V		-15		uA
Switch frequency	FSW	RRT=260K	100	160	220	KHZ
Switch frequency range ⁴	FSW		100		700	KHZ
Minimum ontime ⁵	TON_MIN			120		nS
Minimum off time	TOFF_MIN	VFB=0V		150		nS
En shutdown threshold ⁴	VEN_TH	VEN RISING ,FB=0.6V	1.0	1.3	1.6	V
En shutdown hysteresis ⁴	VEN_HYST			100		MV
Thermal shutdown ⁴	TTSD			137		°C
Thermal shutdown recovery hysteresis ⁵	TTSDR			15		°C

Note: 4) Guaranteed by design.



Functional Block Diagram

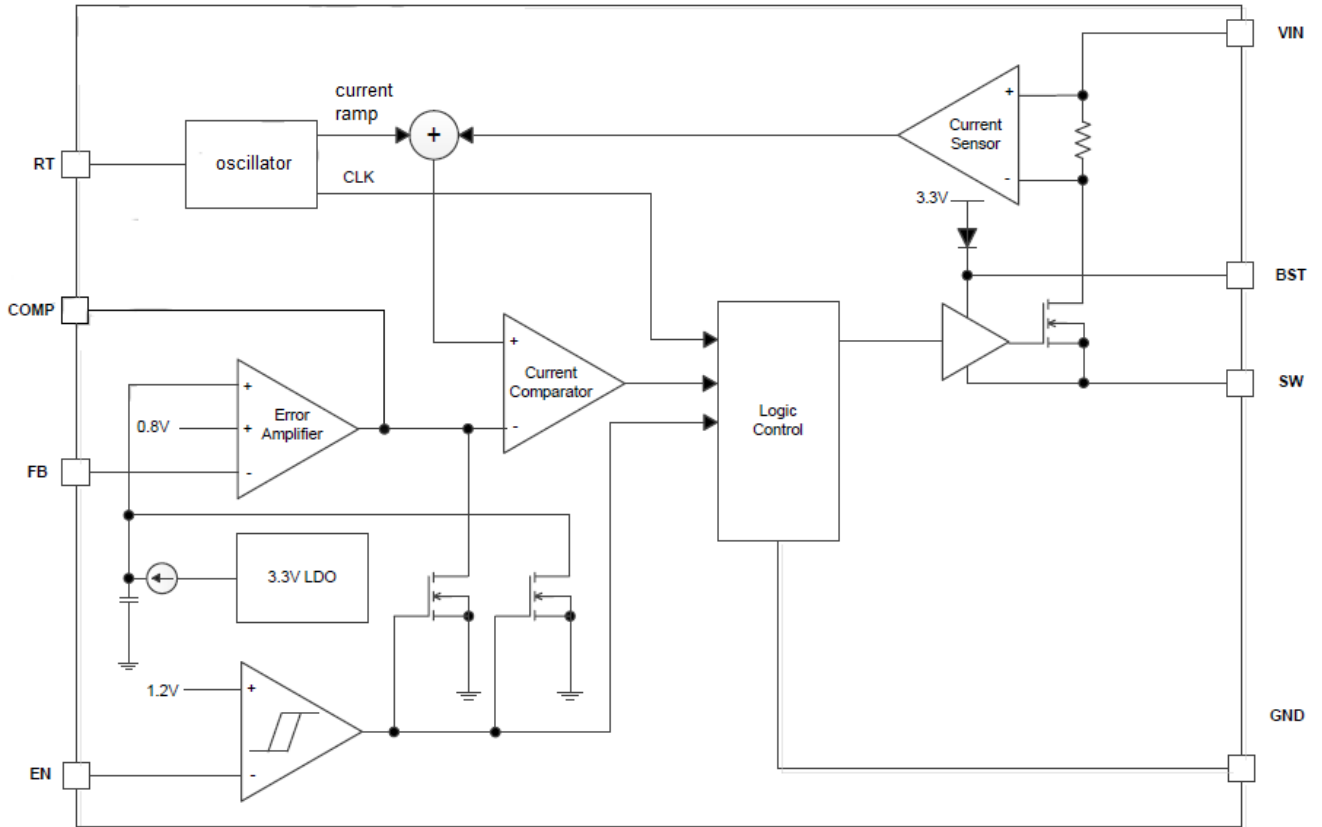



TYPICAL PERFORMANCE CHARACTERISTICS

Vin = 12V, Vout = 5V, Fs=500KHz, L = 10μH, Cout = 44μF, TA = +25°C, unless otherwise noted
Steady State Test Iout=3A Startup through Enable Iout=3A (Resistive load) Shutdown through Enable

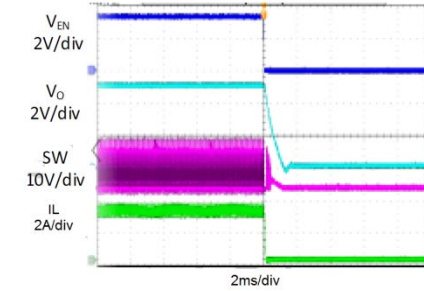
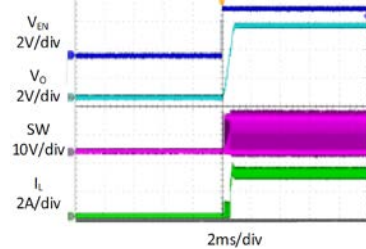
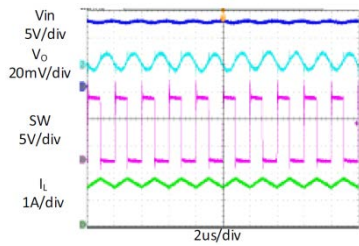

Vout = 5V, L = 10μH, Cout = 44μF, TA = +25°C, unless otherwise noted

Quiescent Current Vs. Input Voltage

VIN=12V ~ 40V, VEN=3.3V, VFB=1.2V

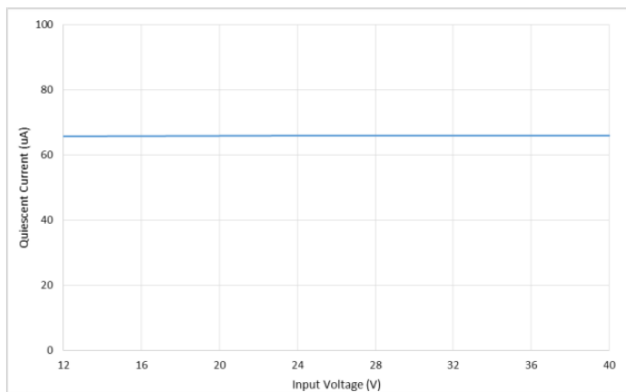

Shutdown Current Vs. Input Voltage

VIN=12V ~ 40V, VEN=0V, VFB=0.3V

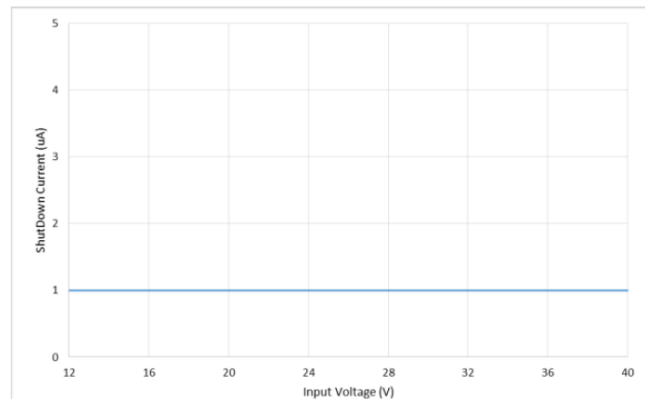

Efficiency@500KHz

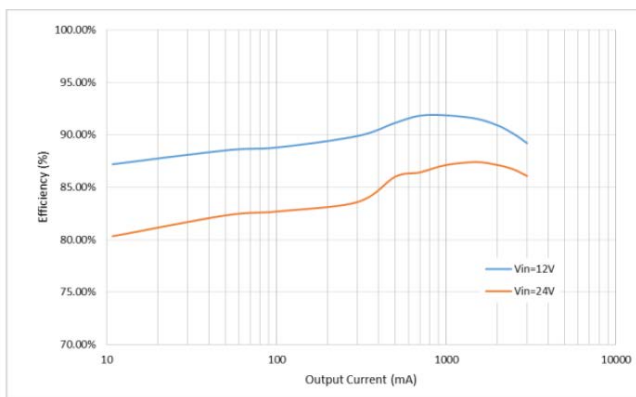

Load Regulation @500KHz

