

High Efficiency 8A Synchronous Buck Converter

Features

- Ultra-High Efficiency
- Integrated 20mΩ at Vcc=5V N-Channel MOSFET for Low Side
- Integrated 20mΩ at Vcc=5V N-Channel MOSFET for High Side
- No Current-Sense Resistor (Lossless I_{LIMIT})
- Quasi-PWM with 100ns Load-Step Response
- 1% V_{OUT} Accuracy Over Line and Load
- Programmable Switching Frequency
- Adjustable Output Range from 0.75V
- 4.5V to 28V Adapter or Battery Input Range
- Integrated Boost Switch
- OVP & UVP
- Over Temperature Protection (non-latch)
- 3.3ms Soft-Start
- Power-Good Indicator
- Fixed 5V, 20mA Linear Regulator

Applications

- LCD Monitor/LCD TV
- Notebook Computers
- I/O Supply
- Chipset/RAM Supply as Low as 0.75V
- Networking Power Supply

General Description

G5312 is a 8A, synchronous DC/DC buck converter with integrated 20mΩ N-channel high-side MOSFET and 20mΩ N-channel low-side MOSFET. It uses constant on-time control scheme to handle wide input/output voltage ratios with ease and provides 100ns “instant-on” response to load transients while maintaining a relatively constant switching frequency. The G5312 achieves high efficiency at a reduced cost by eliminating the current-sense resistor found in traditional current-mode PWMs. Single-stage buck conversion allows these devices to directly step down high-voltage batteries for the highest possible efficiency. The built-in 5V LDO supports 20mA for internal circuits. The G5312 is intended for the main power supply of LCD TV, Notebook Computer, or other low-voltage supplies as low as 0.75V. The G5312 is available in QFN4X4-28 package.

Ordering Information

ORDER NUMBER	MARKING	TEMP. RANGE	PACKAGE (Green)
G5312QN1U	5312	-40°C to +85°C	QFN4X4-28
G5312QN2U	5312	-40°C to +85°C	QFN4X4-28

Note:QN: QFN4X4-28

1 & 2: Leadframe Code

U : Tape & Reel

Pin Configuration

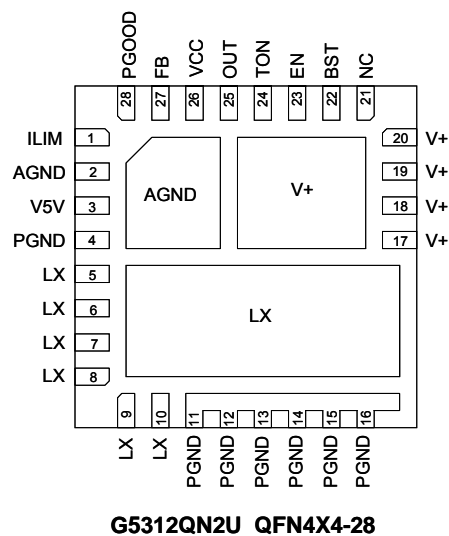
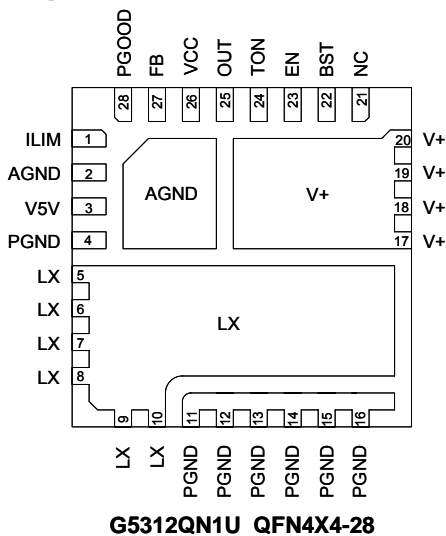

Note: Recommend connecting the Thermal Pad to the Ground for excellent power dissipation.