

Switched Capacitor Voltage Inverter with Shutdown

Features

- Inverts Input Supply Voltage
- 25mA Output Current with a Voltage Drop of 250mV
- 0.45mA Quiescent Current at 3.3V Supply Voltage
- 99% Voltage Conversion Efficiency
- 1.8V to 5V operating range
- Require Only Two Capacitors
- Over-Temperature Protection
- Logic Controlled Shutdown
- 6-Pin SOT-23 Package

Applications

- Cell Phone
- Small LCD Panels
- Portable Equipment
- Handy-Terminals, PDAs
- Battery-Operated Equipment

General Description

The G5930 is an unregulated charge-pump voltage inverter which may be used to generate a negative supply from positive input. Input voltages ranging from +1.8V to +5V can be inverted into a -1.8V to -5V output supply. The device is ideal for both battery-powered and board level voltage conversion applications with a typical operating current of 0.45mA at 3.3V supply.

The G5930 can deliver 25mA output current with a voltage drop of 250mV. The parts are over-temperature protected.

Applications include cell phones, PDAs, and other portable equipment. The device is available in a space-saving 6-pin SOT-23 Package.

Ordering Information

ORDER NUMBER	MARKING	TEMP. RANGE	PACKAGE (Pb free)
G5930TBU	5930x	-40°C to 85°C	SOT-23-6

Note: TB : SOT23-6

U: Tape & Reel

Pin Configuration

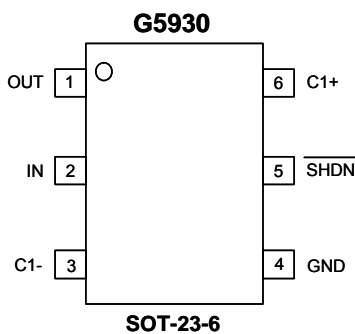

Typical Application Circuit

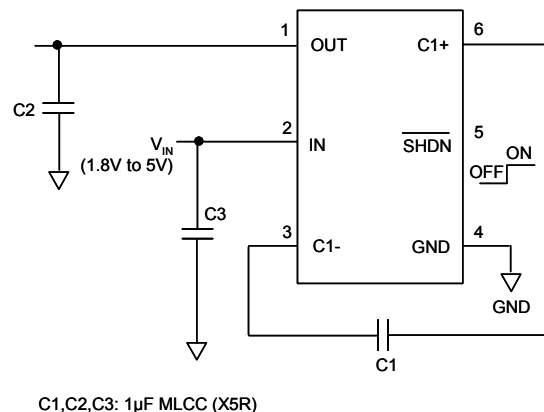

**Absolute Maximum Ratings**

IN to GND Voltage Range.....-0.3V to +5.5V
 OUT to GND Voltage Range.....-5.5V to +0.3V
 C1+ to GND Voltage Range.....-0.3V to (V_{IN}+0.3V)
 C1- to GND Voltage Range.....(V_{OUT}-0.3V) to +0.3V
 SHDN to GND Voltage Range.....-0.3V to (V_{IN}+0.3V)
 Operating Temperature Range.....-40°C to 85°C
 OUT Short Circuit to GND.....Indefinite

Storage Temperature.....-65°C to 150°C
 Junction Temperature.....150°C
 Reflow Temperature (soldering, 10sec).....260°C
 Continuous Power Dissipation (T_A=70°C)
 SOT-23-6 (derate 8.7mW/°C above 70°C).....696mW
 ESD Rating HBM.....2000V

Note: Human body model is a 100pF capacitor discharged through a 1.5kΩ resistor into each pin.

Electrical Characteristics

(V_{IN}=+3.3V, C1 = C2 = C3= 1μF, T_A= -40 to 85°C unless otherwise noted. Typical values is at T_A=25°C.)

PARAMETER	CONDITION	MIN	TYP	MAX	UNIT
Input Voltage, V _{IN}	R _{LOAD} =10kΩ	1.8	---	5	V
Supply Current, I _Q	T _A =25°C	---	0.45	0.55	mA
Charge Pump Frequency, F _{SW}	V _{IN} =5V	200	270	330	KHz
Output Resistance(Note)	I _{LOAD} =10mA	---	8.3	---	Ω
Output Ripple	I _{LOAD} =5mA	---	14	---	mV p-p
	I _{LOAD} =25mA	---	56	---	mV p-p
Voltage Conversion Efficiency	No Load	99	---	---	%
Power Efficiency	I _{LOAD} =5mA	---	93	---	%
SHDN Input Logic High		0.7xV _{IN}	---	---	V
SHDN Input Logic Low		---	---	0.2	V

Electrical Characteristics

(V_{IN}=+5V, C1 = C2 = C3= 1μF, T_A= -40 to 85°C unless otherwise noted. Typical values is at T_A=25°C.)

PARAMETER	CONDITION	MIN	TYP	MAX	UNIT
Supply Current, I _Q	T _A =25°C	---	0.92	1.1	mA
Charge Pump Frequency, F _{SW}	V _{IN} =5V	---	260	---	KHz
Output Resistance(Note)	I _{LOAD} =10mA	---	8.8	---	Ω
Output Ripple	I _{LOAD} =5mA	---	25	---	mV p-p
	I _{LOAD} =25mA	---	100	---	mV p-p
Voltage Conversion Efficiency	No Load	99	---	---	%
Power Efficiency	I _{LOAD} =10mA	---	90	---	%
SHDN Input Logic High		0.7xV _{IN}	---	---	V
SHDN Input Logic Low		---	---	0.2	V

Note: Capacitor contribution (ESR component plus (1/F_{SW}) · C) is approximately 20% of output.

Typical Performance Characteristics

($V_{IN}=3.3V$, $C_1=C_2=C_3=1\mu F$, $T_A=25^\circ C$, unless otherwise noted.)

Output Voltage vs. Current

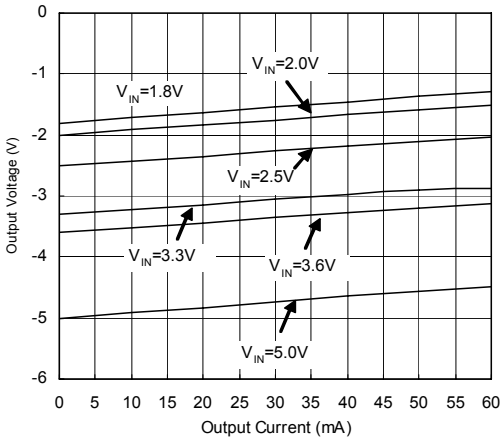

Output Voltage vs Output Current at $V_{IN}=+5V$

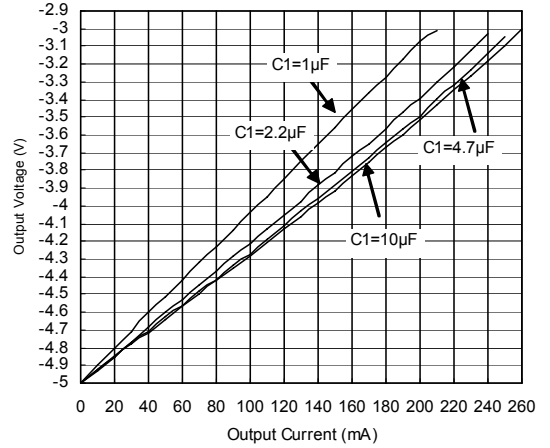

Output Voltage vs. Temperature

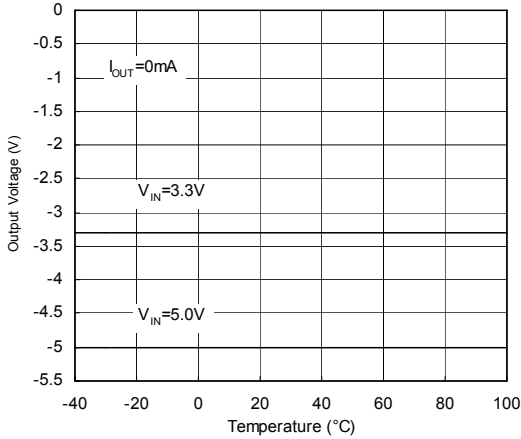

Output Resistance vs. Input Voltage

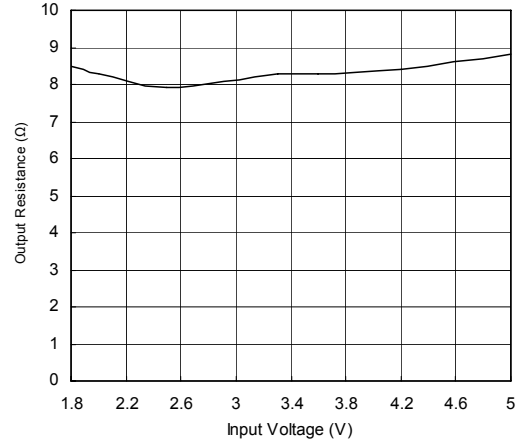

Output Resistance vs. Temperature

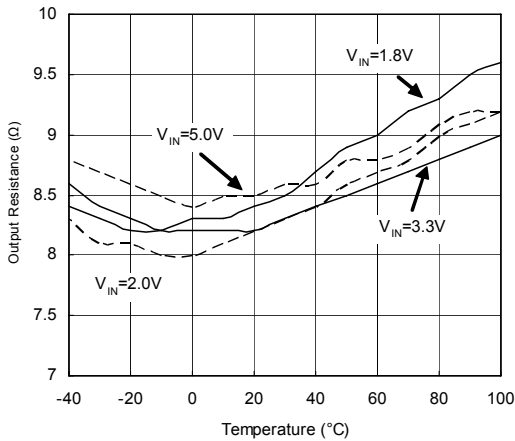

Frequency vs. Input Voltage

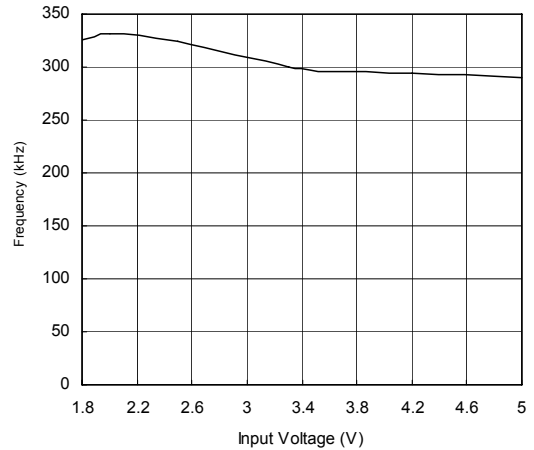

Typical Performance Characteristics (continued)

Frequency vs. Temperature

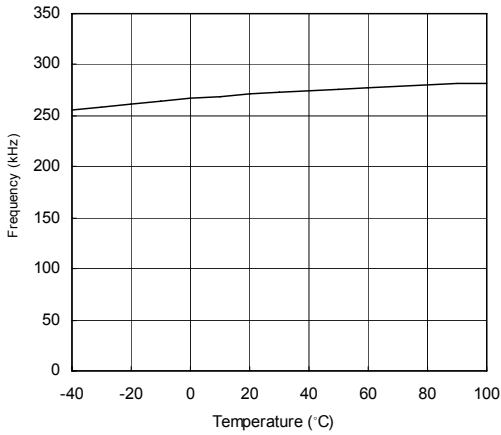

Supply Current vs. Input Voltage

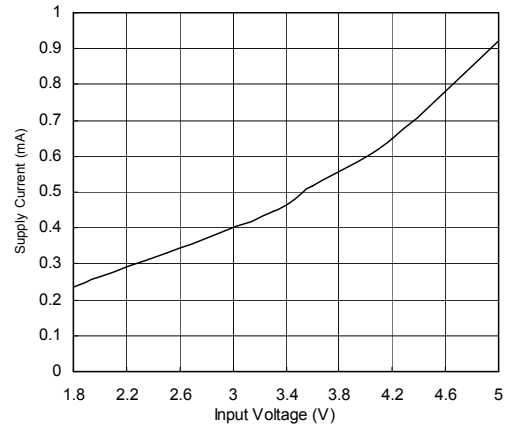

Supply Current vs. Temperature

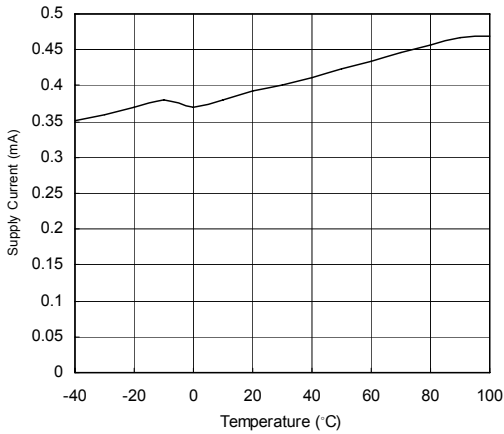

Efficiency vs. Output Current

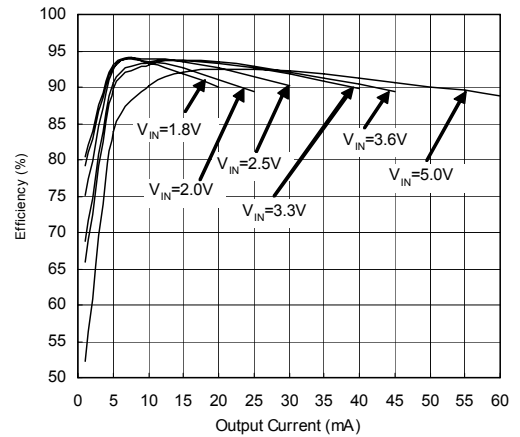

Output Ripple Waveform at VIN=+3.3V

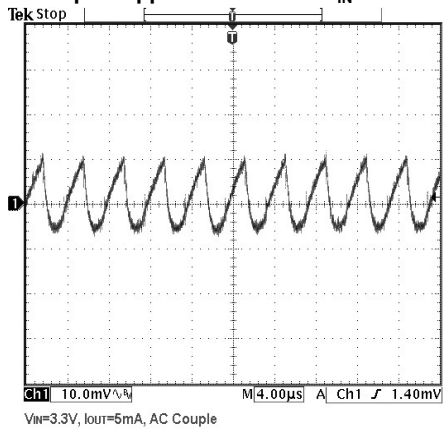

Output Ripple Waveform at VIN=+5V

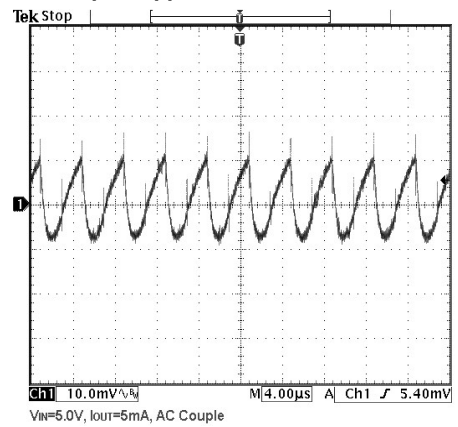

Typical Performance Characteristics (continued)

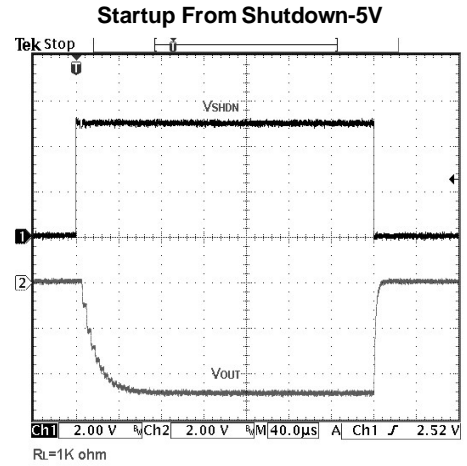
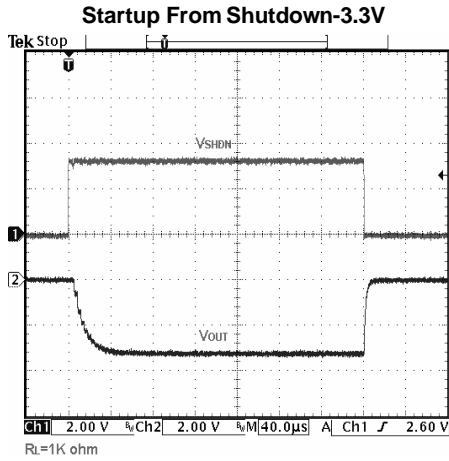

Recommended Minimum Footprint

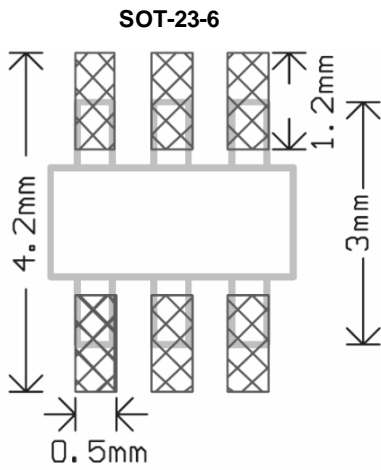

Pin Descriptions

PIN	NAME	FUNCTION
1	OUT	Inverting Charge-Pump Output
2	IN	Power-Supply Positive Voltage Input
3	C1-	Flying Capacitor's Negative Terminal
4	GND	Ground
5	SHDN	Inverting Shutdown Input
6	C1+	Flying Capacitor's Positive Terminal

Detailed Description

The G5930 contains four large switches which are switched in a sequence to invert the input supply voltage. Energy transfer and storage are provided by external capacitors. Fig. 1 illustrates the voltage conversion scheme. When S1 and S3 are closed, C1 charges to the supply voltage V_{IN} . During this time interval, switches S2 and S4 are open. In the second time interval, S1 and S3 are open; at the same time, S2 and S4 are closed, C1 is charging C2. After a number of cycles, the voltage across C2 will be pumped to V_{IN} . Since the anode of C2 is connected to ground, the output at the cathode of C2 equals $-(V_{IN})$ when there are no load current.

The G5930 has a logical-controlled shutdown input. Driving $\overline{\text{SHDN}}$ low places the G5930 in a low-power shutdown mode, and the charge pump switching halts. In the shutdown mode, supply current is smaller than $1\mu\text{A}$. Besides, the OUT is actively pulled to ground.

The main application of G5930 is to generate a negative supply voltage. The range of the input supply voltage is 1.8V to 5V. The output characteristics of this

circuit can be approximated by an ideal voltage source in series with a resistance. The voltage source equals $-(V_{IN})$. The output resistance, R_{out} , is a function of the ON resistance of the internal MOSFET switches, the oscillator frequency, the capacitance and the ESR of both C_1 and C_2 . Since the switching current charging and discharging C_1 is approximately twice as the output current, the effect of the ESR of the pumping capacitor C_1 will be multiplied by four in the output resistance. The output capacitor C_2 is charging and discharging at a current approximately equal to the output current, therefore, this ESR term only counts once in the output resistance. A good approximation of R_{out} is:

$$R_{OUT} \cong 2R_{SW} + \frac{2}{f_{osc} \times C_1} + 4ESR_{C1} + ESR_{C2}$$

Where R_{SW} is the sum of the ON resistance of the internal MOSFET switches shown in Figure 1. High capacitance, low ESR capacitors will reduce the output resistance.

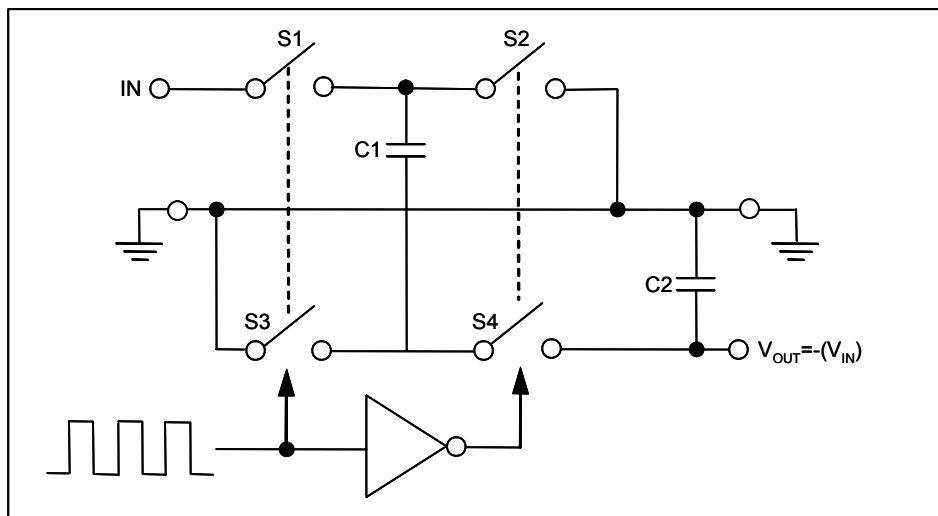

Figure 1. Ideal Voltage Inverter

Application Information

Table 1. Low-ESR Capacitor Manufacturers

PRODUCTION METHOD	MANUFACTURER	SERIES
Surface-Mount Ceramic	AVX	X7R
	Matsuo	X7R

Capacitor Selection

To maintain the lowest output resistance, use capacitors with low ESR (Table 1). The charge-pump output resistance is a function of C1's and C2's ESR. Therefore, minimizing the charge-pump capacitor's ESR minimizes the total output resistance.

Flying Capacitor (C1)

Increasing the flying capacitor's value reduces the output resistance. Above a certain point, increasing C1's capacitance has a negligible effect because the output resistance becomes dominated by the internal switch resistance and capacitor ESR.

Output Capacitor (C2)

Increasing the output capacitor's value reduces the output ripple voltage. Decreasing its ESR reduces both output resistance and ripple. Lower capacitance values can be used with light loads if higher output ripple can be tolerated. Use the following equation to calculate the peak-to-peak ripple:

$$V_{\text{RIPPLE}} = \frac{I_L}{f_{\text{OSC}} \times C2} + 2xI_L + \text{ESR}_{C2}$$

The output resistance is dependent on the capacitance and ESR values of the external capacitors. The output voltage drop is the load current times the output resistance, and the power efficiency is

$$\eta = \frac{P_{\text{OUT}}}{P_{\text{IN}}} = \frac{I_L^2 R_L}{I_L^2 R_L + I_L^2 R_{\text{OUT}} + I_Q(V_{\text{IN}})}$$

Where $I_Q(V_{\text{IN}})$ is the quiescent power loss of the IC device, and $I_L^2 R_{\text{out}}$ is the conversion loss associated with the switch on-resistance, the two external capacitors and their ESRs.

Input Bypass Capacitor (C3)

Bypass the incoming supply to reduce its AC impedance and the impact of the G5930's switching noise. A bypass capacitor with a value equal to that of C1 is recommended.

Voltage Inverter

The most common application for these devices is a charge-pump voltage inverter (Figure 2). This application requires only two external components—capacitors C1 and C2—plus a bypass capacitor, if necessary.

Layout and Grounding

Good layout is important, primarily for good noise performance. To ensure good layout, mount all components as close together as possible, keep traces short to minimize parasitic inductance and capacitance, and use a ground plane.

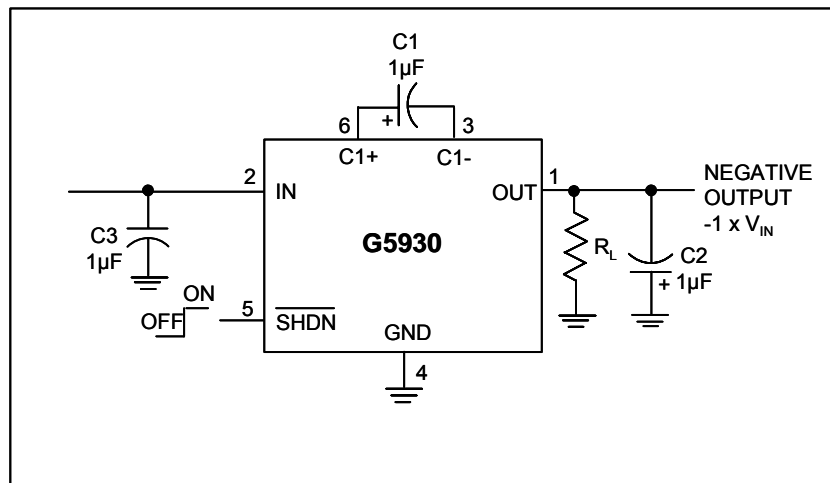
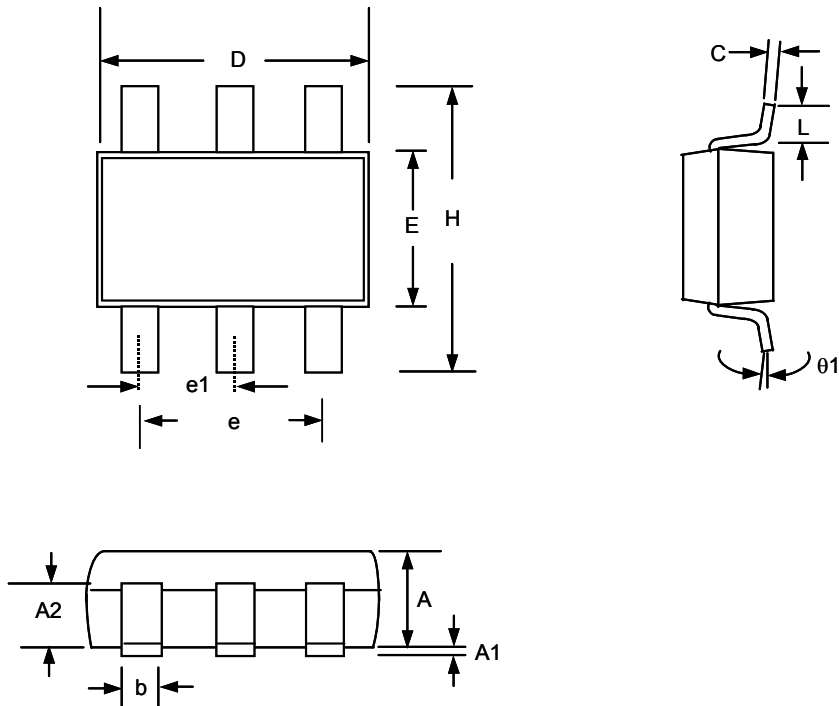

Figure 2. Typical Application Circuit

Package Information



Note:

1. Package body sizes exclude mold flash protrusions or gate burrs
2. Tolerance ± 0.1000 mm (4mil) unless otherwise specified
3. Coplanarity: 0.1000mm
4. Dimension L is measured in gage plane

SYMBOL	DIMENSIONS IN MILLIMETER		
	MIN	NOM	MAX
A	1.00	1.10	1.30
A1	0.00	-----	0.10
A2	0.70	0.80	0.90
b	0.35	0.40	0.50
C	0.10	0.15	0.25
D	2.70	2.90	3.10
E	1.40	1.60	1.80
e	-----	1.90(TYP)	-----
e1	-----	0.95	-----
H	2.60	2.80	3.00
L	0.37	-----	-----
$\theta 1$	1°	5°	9°

Taping Specification

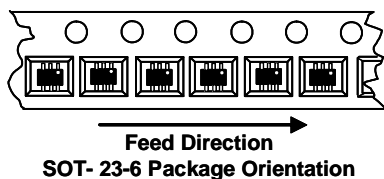

PACKAGE	Q'TY/REEL
SOT-23-6	3,000 ea

GMT Inc. does not assume any responsibility for use of any circuitry described, no circuit patent licenses are implied and GMT Inc. reserves the right at any time without notice to change said circuitry and specifications.