



# Microprocessor Reset IC

## Features

- Precision Monitoring of +3V, +3.3V, and +5V Power-Supply Voltages
- Fully Specified Over Temperature
- Available in Three Output Configurations
  - Push-Pull  $\overline{\text{RESET}}$  Output (G670L)
  - Push-Pull  $\text{RESET}$  Output (G670H)
  - Open-Drain  $\overline{\text{RESET}}$  Output (G671L)
- 2ms max Power-On Reset Pulse Width
- 14 $\mu\text{A}$  Supply Current
- Guaranteed Reset Valid to  $V_{\text{CC}} = +1\text{V}$
- Power Supply Transient Immunity
- No External Components
- 3-Pin SOT-23, TO-92 and SOT-89 Packages
- 2% Threshold Accuracy

## Applications

- Computers
- Controllers
- Intelligent Instruments
- Critical  $\mu\text{P}$  and  $\mu\text{C}$  Power Monitoring
- Portable / Battery-Powered Equipment
- Automotive

## General Description

The G670/G671 are microprocessor ( $\mu\text{P}$ ) supervisory circuits used to monitor the power supplies in  $\mu\text{P}$  and digital systems. They provide excellent circuit reliability and low cost by eliminating external components and adjustments when used with +5V, +3.3V, +3.0V- powered circuits.

These circuits perform a single function: they assert a reset signal whenever the  $V_{\text{CC}}$  supply voltage declines below a preset threshold. Reset thresholds suitable for operation with a variety of supply voltages are available.

The G671L has an open-drain output stage, while the G670 have push-pull outputs. The G671L's open-drain  $\overline{\text{RESET}}$  output requires a pull-up resistor that can be connected to a voltage higher than  $V_{\text{CC}}$ . The G670L have an active-low  $\overline{\text{RESET}}$  output, while the G670H has an active-high  $\text{RESET}$  output. The reset comparator is designed to ignore fast transients on  $V_{\text{CC}}$ , and the outputs are guaranteed to be in the correct logic state for  $V_{\text{CC}}$  down to 1V.

Low supply current makes the G670/G671 ideal for use in portable equipment. The G670/G671 are available in 3-pin SOT-23, TO-92 and SOT-89 packages.

## Pin Configuration

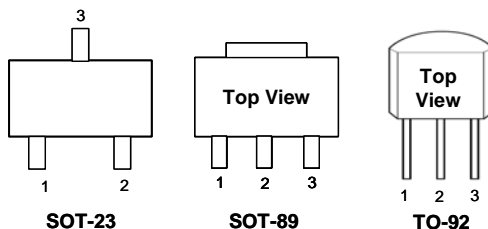

## Typical Application Circuit

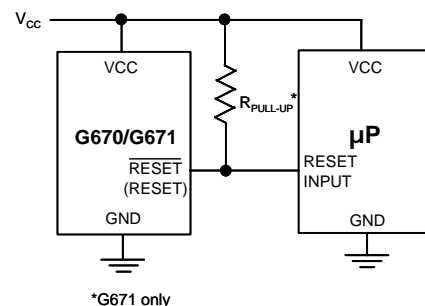



## Ordering Information

ORDER NUMBER	ORDER NUMBER (Pb free)	TEMP. RANGE	OUTPUT TYPE
G670LxxxTDxB	G670LxxxTDxBf	-40°C ~ +105°C	Push-Pull Active Low
G670HxxxTDxB	G670HxxxTDxBf	-40°C ~ +105°C	Push-Pull Active High
G671LxxxTDxB	G671LxxxTDxBf	-40°C ~ +105°C	Open-Drain
G670LxxxT2xU	G670LxxxT2xUf	-40°C ~ +105°C	Push-Pull Active Low
G670HxxxT2xU	G670HxxxT2xUf	-40°C ~ +105°C	Push-Pull Active High
G671LxxxT2xU	G671LxxxT2xUf	-40°C ~ +105°C	Open-Drain
G670LxxxT7xU	G670LxxxT7xUf	-40°C ~ +105°C	Push-Pull Active Low
G670HxxxT7xU	G670HxxxT7xUf	-40°C ~ +105°C	Push-Pull Active High
G671LxxxT7xU	G671LxxxT7xUf	-40°C ~ +105°C	Open-Drain

Note: U : Tape & Reel B: Bag

## Order Number Identification

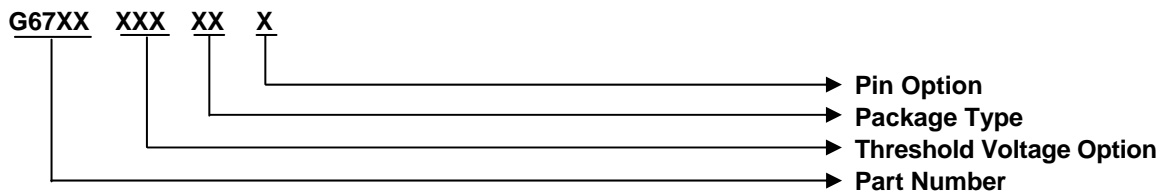

### PART NUMBER

G670L : Push-Pull Active Low Output  
 G670H : Push-Pull Active High Output  
 G671L : Open-Drain Output

### THRESHOLD VOLTAGE OPTION

\* xxx specifies the threshold voltage.  
 e.g. 263 denotes the 2.64V threshold voltage.

### PACKAGE TYPE

TD : TO-92  
 T2 : SOT-89  
 T7 : SOT-23

### PIN OPTION

1	2	3
1 : $\overline{\text{RESET}}$	GND	V <sub>CC</sub>
2 : RESET	V <sub>CC</sub>	GND
3 : GND	$\overline{\text{RESET}}$	V <sub>CC</sub>
4 : GND	V <sub>CC</sub>	$\overline{\text{RESET}}$
5 : V <sub>CC</sub>	GND	$\overline{\text{RESET}}$
6 : V <sub>CC</sub>	$\overline{\text{RESET}}$	GND

\*RESET for G670H

**Selector Guide**

ORDER NUMBER	ORDER NUMBER (Pb free)	RESET THRESHOLD (V)	OUTPUT TYPE	TOP MARK
				TO-92
G671L463TD5B	G671L463TD5Bf	4.60	Open-Drain	663G xx
G671L438TD5B	G671L438TD5Bf	4.32	Open-Drain	663F xx
G671L400TD5B	G671L400TD5Bf	3.96	Open-Drain	663E xx
G671L330TD5B	G671L330TD5Bf	3.30	Open-Drain	663D xx
G671L308TD5B	G671L308TD5Bf	3.10	Open-Drain	663C xx
G671L293TD5B	G671L293TD5Bf	2.91	Open-Drain	663B xx
G671L263TD5B	G671L263TD5Bf	2.64	Open-Drain	663A xx
G670H463TD5B	G670H463TD5Bf	4.60	Push-Pull RESET	662N xx
G670H438TD5B	G670H438TD5Bf	4.32	Push-Pull RESET	662M xx
G670H400TD5B	G670H400TD5Bf	3.96	Push-Pull RESET	662L xx
G670H330TD5B	G670H330TD5Bf	3.30	Push-Pull RESET	662K xx
G670H308TD5B	G670H308TD5Bf	3.10	Push-Pull RESET	662J xx
G670H293TD5B	G670H293TD5Bf	2.91	Push-Pull RESET	662I xx
G670H263TD5B	G670H263TD5Bf	2.64	Push-Pull RESET	662H xx
G670L463TD5B	G670L463TD5Bf	4.60	Push-Pull	662G xx
G670L438TD5B	G670L438TD5Bf	4.32	Push-Pull	662F xx
G670L400TD5B	G670L400TD5Bf	3.96	Push-Pull	662E xx
G670L330TD5B	G670L330TD5Bf	3.30	Push-Pull	662D xx
G670L308TD5B	G670L308TD5Bf	3.10	Push-Pull	662C xx
G670L293TD5B	G670L293TD5Bf	2.91	Push-Pull	662B xx
G670L263TD5B	G670L263TD5Bf	2.64	Push-Pull	662A xx

**Note: TD: TO-92**

Not all product options are ready for mass production, please contact factory for availability.

**Selector Guide**

ORDER NUMBER	ORDER NUMBER (Pb free)	RESET THRESHOLD (V)	OUTPUT TYPE	TOP MARK
				SOT-89
G671L463T25U	G671L463T25Uf	4.60	Open-Drain	663G xx
G671L438T25U	G671L438T25Uf	4.32	Open-Drain	663F xx
G671L400T25U	G671L400T25Uf	3.96	Open-Drain	663E xx
G671L330T25U	G671L330T25Uf	3.30	Open-Drain	663D xx
G671L308T25U	G671L308T25Uf	3.10	Open-Drain	663C xx
G671L293T25U	G671L293T25Uf	2.91	Open-Drain	663B xx
G671L263T25U	G671L263T25Uf	2.64	Open-Drain	663A xx
G670H463T25U	G670H463T25Uf	4.60	Push-Pull RESET	662N xx
G670H438T25U	G670H438T25Uf	4.32	Push-Pull RESET	662M xx
G670H400T25U	G670H400T25Uf	3.96	Push-Pull RESET	662L xx
G670H330T25U	G670H330T25Uf	3.30	Push-Pull RESET	662K xx
G670H308T25U	G670H308T25Uf	3.10	Push-Pull RESET	662J xx
G670H293T25U	G670H293T25Uf	2.91	Push-Pull RESET	662I xx
G670H263T25U	G670H263T25Uf	2.64	Push-Pull RESET	662H xx
G670L463T25U	G670L463T25Uf	4.60	Push-Pull	662G xx
G670L438T25U	G670L438T25Uf	4.32	Push-Pull	662F xx
G670L400T25U	G670L400T25Uf	3.96	Push-Pull	662E xx
G670L330T25U	G670L330T25Uf	3.30	Push-Pull	662D xx
G670L308T25U	G670L308T25Uf	3.10	Push-Pull	662C xx
G670L293T25U	G670L293T25Uf	2.91	Push-Pull	662B xx
G670L263T25U	G670L263T25Uf	2.64	Push-Pull	662A xx

**Note: T2: SOT-89**

Not all product options are ready for mass production, please contact factory for availability.

**Selector Guide**

ORDER NUMBER	ORDER NUMBER (Pb free)	RESET THRESHOLD (V)	OUTPUT TYPE	TOP MARK
				SOT-23
G671L463T71U	G671L463T71Uf	4.60	Open-Drain	669Gx
G671L438T71U	G671L438T71Uf	4.32	Open-Drain	669Fx
G671L400T71U	G671L400T71Uf	3.96	Open-Drain	669Ex
G671L330T71U	G671L330T71Uf	3.30	Open-Drain	669Dx
G671L308T71U	G671L308T71Uf	3.10	Open-Drain	669Cx
G671L293T71U	G671L293T71Uf	2.91	Open-Drain	669Bx
G671L263T71U	G671L263T71Uf	2.64	Open-Drain	669Ax
G670H463T71U	G670H463T71Uf	4.60	Push-Pull RESET	668Nx
G670H438T71U	G670H438T71Uf	4.32	Push-Pull RESET	668Mx
G670H400T71U	G670H400T71Uf	3.96	Push-Pull RESET	668Lx
G670H330T71U	G670H330T71Uf	3.30	Push-Pull RESET	668Kx
G670H308T71U	G670H308T71Uf	3.10	Push-Pull RESET	668Jx
G670H293T71U	G670H293T71Uf	2.91	Push-Pull RESET	668Ix
G670H263T71U	G670H263T71Uf	2.64	Push-Pull RESET	668Hx
G670L463T71U	G670L463T71Uf	4.60	Push-Pull	668Gx
G670L438T71U	G670L438T71Uf	4.32	Push-Pull	668Fx
G670L400T71U	G670L400T71Uf	3.96	Push-Pull	668Ex
G670L330T71U	G670L330T71Uf	3.30	Push-Pull	668Dx
G670L308T71U	G670L308T71Uf	3.10	Push-Pull	668Cx
G670L293T71U	G670L293T71Uf	2.91	Push-Pull	668Bx
G670L263T71U	G670L263T71Uf	2.64	Push-Pull	668Ax

**Note: T7: SOT-23**

Not all product options are ready for mass production, please contact factory for availability.

**Selector Guide**

ORDER NUMBER	ORDER NUMBER (Pb free)	RESET THRESHOLD (V)	OUTPUT TYPE	TOP MARK
				SOT-23
G671L463T72U	G671L463T72Uf	4.60	Open-Drain	667Gx
G671L438T72U	G671L438T72Uf	4.32	Open-Drain	667Fx
G671L400T72U	G671L400T72Uf	3.96	Open-Drain	667Ex
G671L330T72U	G671L330T72Uf	3.30	Open-Drain	667Dx
G671L308T72U	G671L308T72Uf	3.10	Open-Drain	667Cx
G671L293T72U	G671L293T72Uf	2.91	Open-Drain	667Bx
G671L263T72U	G671L263T72Uf	2.64	Open-Drain	667Ax
G670H463T72U	G670H463T72Uf	4.60	Push-Pull RESET	666Nx
G670H438T72U	G670H438T72Uf	4.32	Push-Pull RESET	666Mx
G670H400T72U	G670H400T72Uf	3.96	Push-Pull RESET	666Lx
G670H330T72U	G670H330T72Uf	3.30	Push-Pull RESET	666Kx
G670H308T72U	G670H308T72Uf	3.10	Push-Pull RESET	666Jx
G670H293T72U	G670H293T72Uf	2.91	Push-Pull RESET	666Ix
G670H263T72U	G670H263T72Uf	2.64	Push-Pull RESET	666Hx
G670L463T72U	G670L463T72Uf	4.60	Push-Pull	666Gx
G670L438T72U	G670L438T72Uf	4.32	Push-Pull	666Fx
G670L400T72U	G670L400T72Uf	3.96	Push-Pull	666Ex
G670L330T72U	G670L330T72Uf	3.30	Push-Pull	666Dx
G670L308T72U	G670L308T72Uf	3.10	Push-Pull	666Cx
G670L293T72U	G670L293T72Uf	2.91	Push-Pull	666Bx
G670L263T72U	G670L263T72Uf	2.64	Push-Pull	666Ax

**Note: T7: SOT-23**

Not all product options are ready for mass production, please contact factory for availability.

**Selector Guide**

ORDER NUMBER	ORDER NUMBER (Pb free)	RESET THRESHOLD (V)	OUTPUT TYPE	TOP MARK
				SOT-23
G671L463T73U	G671L463T73Uf	4.60	Open-Drain	671Gx
G671L438T73U	G671L438T73Uf	4.32	Open-Drain	671Fx
G671L400T73U	G671L400T73Uf	3.96	Open-Drain	671Ex
G671L330T73U	G671L330T73Uf	3.30	Open-Drain	671Dx
G671L308T73U	G671L308T73Uf	3.10	Open-Drain	671Cx
G671L293T73U	G671L293T73Uf	2.91	Open-Drain	671Bx
G671L263T73U	G671L263T73Uf	2.64	Open-Drain	671Ax
G670H463T73U	G670H463T73Uf	4.60	Push-Pull RESET	670Nx
G670H438T73U	G670H438T73Uf	4.32	Push-Pull RESET	670Mx
G670H400T73U	G670H400T73Uf	3.96	Push-Pull RESET	670Lx
G670H330T73U	G670H330T73Uf	3.30	Push-Pull RESET	670Kx
G670H308T73U	G670H308T73Uf	3.10	Push-Pull RESET	670Jx
G670H293T73U	G670H293T73Uf	2.91	Push-Pull RESET	670Ix
G670H263T73U	G670H263T73Uf	2.64	Push-Pull RESET	670Hx
G670L463T73U	G670L463T73Uf	4.60	Push-Pull	670Gx
G670L438T73U	G670L438T73Uf	4.32	Push-Pull	670Fx
G670L400T73U	G670L400T73Uf	3.96	Push-Pull	670Ex
G670L330T73U	G670L330T73Uf	3.30	Push-Pull	670Dx
G670L308T73U	G670L308T73Uf	3.10	Push-Pull	670Cx
G670L293T73U	G670L293T73Uf	2.91	Push-Pull	670Bx
G670L263T73U	G670L263T73Uf	2.64	Push-Pull	670Ax

**Note: T7: SOT-23**

Not all product options are ready for mass production, please contact factory for availability.

**Selector Guide**

ORDER NUMBER	ORDER NUMBER (Pb free)	RESET THRESHOLD (V)	OUTPUT TYPE	TOP MARK
				SOT-23
G671L463T76U	G671L463T76Uf	4.60	Open-Drain	665Gx
G671L438T76U	G671L438T76Uf	4.32	Open-Drain	665Fx
G671L400T76U	G671L400T76Uf	3.96	Open-Drain	665Ex
G671L330T76U	G671L330T76Uf	3.30	Open-Drain	665Dx
G671L308T76U	G671L308T76Uf	3.10	Open-Drain	665Cx
G671L293T76U	G671L293T76Uf	2.91	Open-Drain	665Bx
G671L263T76U	G671L263T76Uf	2.64	Open-Drain	665Ax
G670H463T76U	G670H463T76Uf	4.60	Push-Pull RESET	664Nx
G670H438T76U	G670H438T76Uf	4.32	Push-Pull RESET	664Mx
G670H400T76U	G670H400T76Uf	3.96	Push-Pull RESET	664Lx
G670H330T76U	G670H330T76Uf	3.30	Push-Pull RESET	664Kx
G670H308T76U	G670H308T76Uf	3.10	Push-Pull RESET	664Jx
G670H293T76U	G670H293T76Uf	2.91	Push-Pull RESET	664Ix
G670H263T76U	G670H263T76Uf	2.64	Push-Pull RESET	664Hx
G670L463T76U	G670L463T76Uf	4.60	Push-Pull	664Gx
G670L438T76U	G670L438T76Uf	4.32	Push-Pull	664Fx
G670L400T76U	G670L400T76Uf	3.96	Push-Pull	664Ex
G670L330T76U	G670L330T76Uf	3.30	Push-Pull	664Dx
G670L308T76U	G670L308T76Uf	3.10	Push-Pull	664Cx
G670L293T76U	G670L293T76Uf	2.91	Push-Pull	664Bx
G670L263T76U	G670L263T76Uf	2.64	Push-Pull	664Ax

**Note: T7: SOT-23**

Not all product options are ready for mass production, please contact factory for availability.

## Absolute Maximum Ratings

Terminal Voltage (with respect to GND)

$V_{CC}$  ..... -0.3V to +6.0V

RESET,  $\overline{\text{RESET}}$  (push-pull) ..... -0.3V to ( $V_{CC} + 0.3V$ )

$\overline{\text{RESET}}$  (open drain) ..... -0.3V to +6.0V

Input Current,  $V_{CC}$  ..... 20mA

Output Current, RESET,  $\overline{\text{RESET}}$  ..... 20mA

Continuous Power Dissipation ( $T_A = +70^\circ\text{C}$ )

SOT-23 (derate 4mW/ $^\circ\text{C}$  above +70 $^\circ\text{C}$ ) ..... 100mW

SOT-89 (derate 4mW/ $^\circ\text{C}$  above +70 $^\circ\text{C}$ ) ..... 100mW

TO-92 (derate 4mW/ $^\circ\text{C}$  above +70 $^\circ\text{C}$ ) ..... 100mW

Operating Temperature Range. .... -40 $^\circ\text{C}$  to +105 $^\circ\text{C}$

Storage Temperature Range. .... -65 $^\circ\text{C}$  to +150 $^\circ\text{C}$

Reflow Temperature (soldering, 10sec) ..... +260 $^\circ\text{C}$

Stresses beyond those listed under "Absolute Maximum Ratings" may cause permanent damage to the device. These are stress ratings only, and functional operation of the device at these or any other conditions beyond those indicated in the operational sections of the specifications is not implied. Exposure to absolute maximum rating conditions for extended periods may affect device reliability.

## Electrical Characteristics

( $V_{CC}$  = full range,  $T_A = -40^\circ\text{C}$  to +105 $^\circ\text{C}$ , unless otherwise noted. Typical values are at  $T_A = +25^\circ\text{C}$ ,  $V_{CC} = 5V$  for 463/438/400/330 versions,  $V_{CC} = 3.3V$  for 308/293 versions, and  $V_{CC} = 3V$  for 263 version.) (Note 1)

PARAMETER	SYMBOL	CONDITION	MIN	TYP	MAX	UNIT
V <sub>CC</sub> Range		T <sub>A</sub> = 0 $^\circ\text{C}$ +70 $^\circ\text{C}$	1.0	---	5.5	V
		T <sub>A</sub> = -40 $^\circ\text{C}$ +105 $^\circ\text{C}$	1.2	---	5.5	
Supply Current	I <sub>CC</sub>	V <sub>CC</sub> < 5.5V, G67_463/438/400/330_	---	16.5	25	$\mu\text{A}$
		T <sub>A</sub> = -40 $^\circ\text{C}$ +105 $^\circ\text{C}$				
		V <sub>CC</sub> < 3.6V, G67_308/293/263_				
Reset Threshold	V <sub>TH</sub>	G67_463_	4.50	4.60	4.69	V
		G67_438_	4.23	4.32	4.40	
		G67_400_	3.88	3.96	4.04	
		G67_330_	3.24	3.30	3.37	
		G67_308_	3.04	3.10	3.16	
		G67_293_	2.86	2.91	2.96	
		G67_263_	2.59	2.64	2.69	
Reset Threshold Hysteresis	V <sub>HYST</sub>		3.60	5.30	7.00	%
Reset Threshold Tempco			---	40	---	ppm/ $^\circ\text{C}$
V <sub>CC</sub> to Reset Delay (Note 2)		V <sub>CC</sub> = V <sub>TH</sub> to (V <sub>TH</sub> - 100mV)	---	7	---	$\mu\text{s}$
Reset Active Timeout Period		V <sub>CC</sub> = V <sub>TH</sub> max,	---	---	2	ms
RESET Output Current Low (push-pull active low, and open-drain active-low, G670L and G671L)	I <sub>OL</sub>	V <sub>CC</sub> = 2.5V, V <sub>RESET</sub> = 0.5V	8	---	---	mA
RESET Output Current High (push-pull active low, G670L)	I <sub>OH</sub>	V <sub>CC</sub> = 5V, V <sub>RESET</sub> = 4.5V, G670L463/438/400/330	4.5	---	---	mA
		V <sub>CC</sub> = 3.3V, V <sub>RESET</sub> = 2.8V, G670L308/293	3	---	---	
		V <sub>CC</sub> = 3V, V <sub>RESET</sub> = 2.5V, G670L263	2	---	---	
RESET Output Current Low (push-pull active high, G670H)	I <sub>OL</sub>	V <sub>CC</sub> = 5V, V <sub>RESET</sub> = 0.5V, G670H463/438/400/330	16	---	---	mA
		V <sub>CC</sub> = 3.3V, V <sub>RESET</sub> = 0.5V, G670H308/293	12	---	---	
		V <sub>CC</sub> = 3V, V <sub>RESET</sub> = 0.5V, G670H263	10	---	---	
RESET Output Current High (push-pull active high, G670H)	I <sub>OH</sub>	V <sub>CC</sub> = 2.5V, V <sub>RESET</sub> = 2V	2	---	---	mA
RESET Open-Drain Output Leakage Current (G671L)		V <sub>CC</sub> > V <sub>TH</sub> , $\overline{\text{RESET}}$ deasserted	---	---	1	$\mu\text{A}$

Note 1: Production testing done at  $T_A = +25^\circ\text{C}$ ; limits over temperature guaranteed by design.

Note 2: RESET output is for G670L/G671L; While  $\overline{\text{RESET}}$  output is for G670H.

**Typical Operating Characteristics**

( $V_{CC}$  = full range,  $T_A$  =  $-40^{\circ}\text{C}$  to  $+105^{\circ}\text{C}$ , unless otherwise noted. Typical values are at  $T_A$  =  $+25^{\circ}\text{C}$ ,  $V_{CC}$  = 5V for 463/438/400 versions,  $V_{CC}$  = 3.3V for 308/293 versions, and  $V_{CC}$  = 3V for 263 version.)

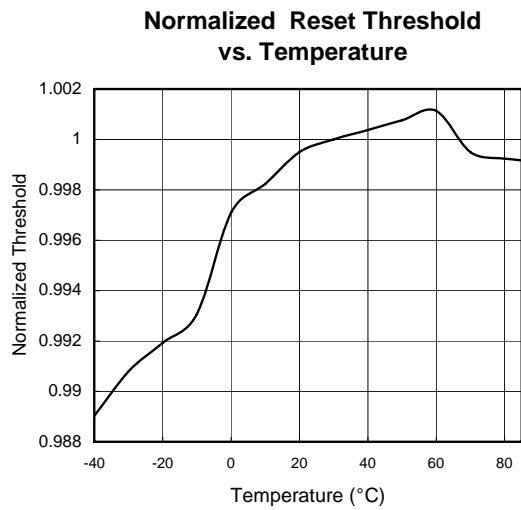
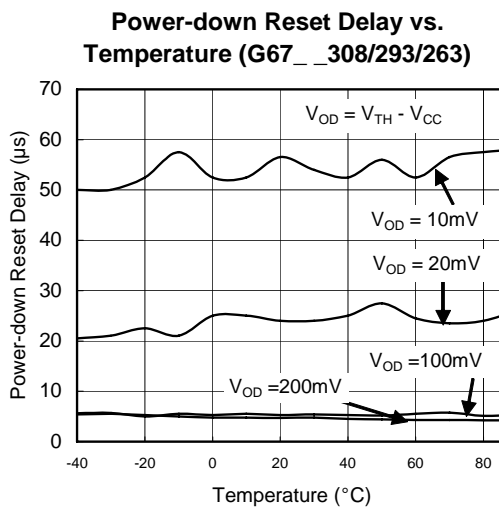
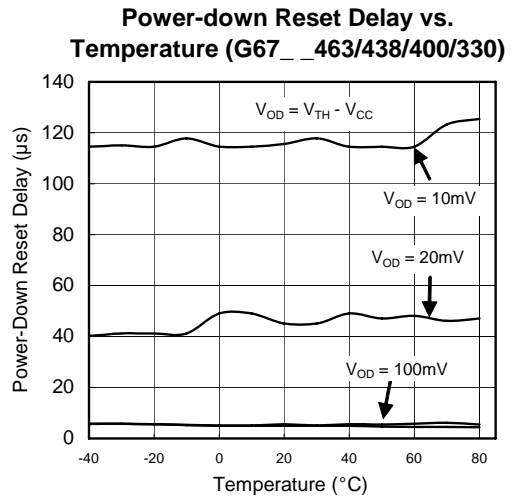
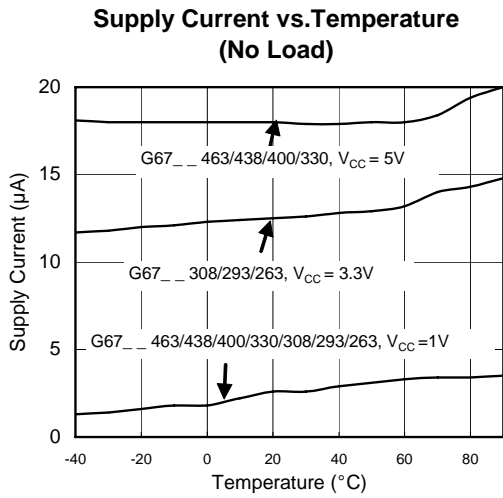

**Recommended Minimum Footprint**

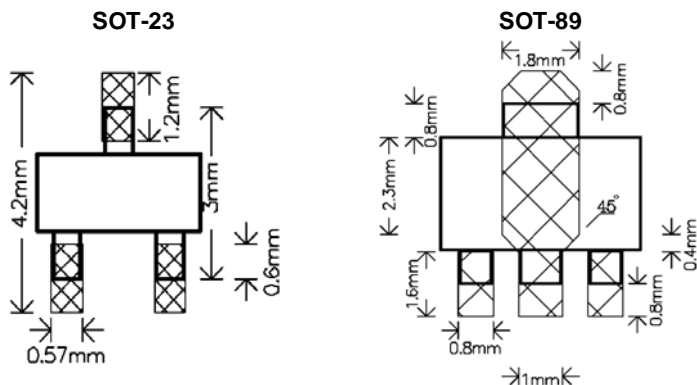



**Pin Description**

NAME	FUNCTION
GND	Ground
(G671L/G670L)	$\overline{\text{RESET}}$ Output remains low while $V_{CC}$ is below the reset threshold, and for at most 2ms after $V_{CC}$ rises above the reset threshold.
RESET (G670H)	RESET Output remains high while $V_{CC}$ is below the reset threshold, and for at most 2ms after $V_{CC}$ rises above the reset threshold.
VCC	Supply Voltage (+5V, +3.3V, +3.0V)

**Detailed Description**

A microprocessor's ( $\mu\text{P}$ 's) reset input starts the  $\mu\text{P}$  in a known state. The G671L/G670L/G670H assert reset to prevent code-execution errors during power-up, power-down, or brownout conditions. They assert a reset signal whenever the  $V_{CC}$  supply voltage declines below a preset threshold, keeping it asserted for at most 2ms after  $V_{CC}$  has risen above the reset threshold. The G671L uses an open-drain output, and the G670L/G670H have a push-pull output stage. Connect a pull-up resistor on the G671L's  $\overline{\text{RESET}}$  output to any supply between 0 and 5.5V.

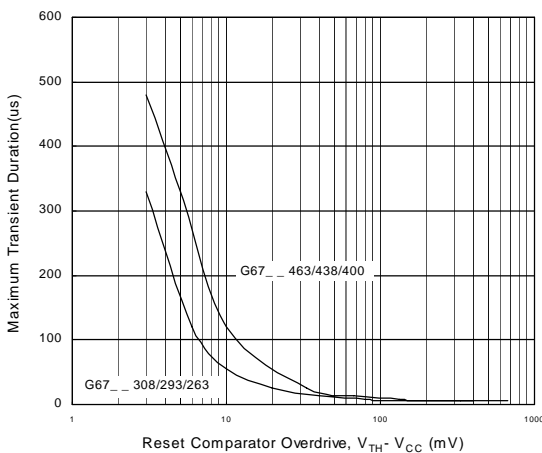

**Figure 1. Maximum Transient Duration Without Causing a Reset Pulse vs. Reset Comparator Overdrive**

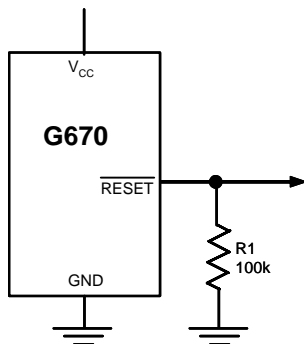

**Figure 2.  $\overline{\text{RESET}}$  Valid to  $V_{CC} = \text{Ground}$  Circuit**

**Applications Information**

**Negative-Going  $V_{CC}$  Transients**

In addition to issuing a reset to the  $\mu\text{P}$  during power-up, power-down, and brownout conditions, the G671L/G670H/G670L are relatively immune to short-duration negative-going  $V_{CC}$  transients (glitches).

Figure 1 shows typical transient duration vs. reset comparator overdrive, for which the G671L/G670H/G670L do not generate a reset pulse. The graph was generated using a negative-going pulse applied to  $V_{CC}$ , starting 0.5V above the actual reset threshold and ending below it by the magnitude indicated (reset comparator overdrive). The graph indicates the maximum pulse width a negative-going  $V_{CC}$  transient can have without causing a reset pulse. As the magnitude of the transient increases (goes farther below the reset threshold), the maximum allowable pulse width decreases. Typically, for the G67\_\_463 and G67\_\_438, a  $V_{CC}$  transient that goes 100mV below the reset threshold and lasts 7 $\mu\text{s}$  or less will not cause a reset pulse. A 0.1 $\mu\text{F}$  bypass capacitor mounted as close as possible to the  $V_{CC}$  pin provides additional transient immunity.

**Ensuring a Valid Reset Output Down to  $V_{CC} = 0$**

When  $V_{CC}$  falls below 1V, the G670  $\overline{\text{RESET}}$  output no longer sinks current—it becomes an open circuit. Therefore, high-impedance CMOS logic inputs connected to  $\overline{\text{RESET}}$  can drift to undetermined voltages. This presents no problem in most applications since most  $\mu\text{P}$  and other circuitry is inoperative with  $V_{CC}$  below 1V. However, in applications where  $\overline{\text{RESET}}$  must be valid down to 0V, adding a pull-down resistor to  $\overline{\text{RESET}}$  causes any stray leakage currents to flow to ground, holding  $\overline{\text{RESET}}$  low (Figure 2). R1's value is not critical; 100k $\Omega$  is large enough not to load  $\overline{\text{RESET}}$  and small enough to pull  $\overline{\text{RESET}}$  to ground. A 100k $\Omega$  pull-up resistor to  $V_{CC}$  is also recommended for the G671L if  $\overline{\text{RESET}}$  is required to remain valid for  $V_{CC} < 1\text{V}$ .

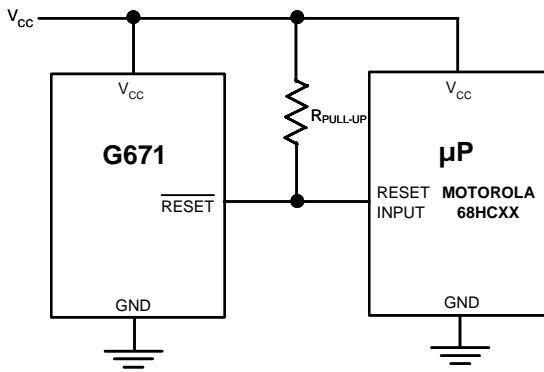

**Figure 3. Interfacing to  $\mu$ Ps with Bidirectional Reset I/O**

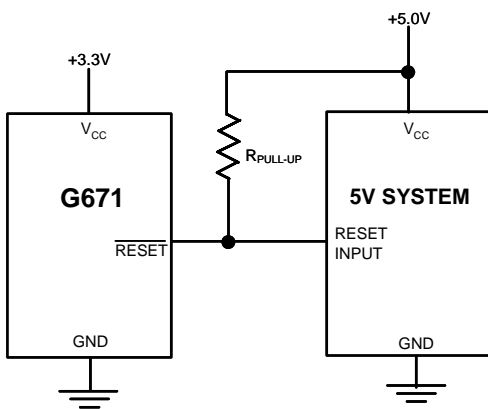

**Figure 4. G671L Open-Drain  $\overline{\text{RESET}}$  Output Allows Use with Multiple Supplies**

**Interfacing to  $\mu$ Ps with Bidirectional Reset Pins**

Since the  $\overline{\text{RESET}}$  output on the G671L is open drain, this device interfaces easily with  $\mu$ Ps that have bidirectional reset pins, such as the Motorola 68HC11. Connecting the  $\mu$ P supervisor's  $\overline{\text{RESET}}$  output directly to the microcontroller's ( $\mu$ C's)  $\overline{\text{RESET}}$  pin with a single pull-up resistor allows either device to assert reset (Figure 3).

**G671L Open-Drain  $\overline{\text{RESET}}$  Output Allows Use with Multiple Supplies**

Generally, the pull-up connected to the G671L will connect to the supply voltage that is being monitored at the IC's  $V_{CC}$  pin. However, some systems may use the open-drain output to level-shift from the monitored supply to reset circuitry powered by some other supply (Figure 4). Note that as the G671L's  $V_{CC}$  decreases below 1V, so does the IC's ability to sink current at  $\overline{\text{RESET}}$ . Also, with any pull-up,  $\overline{\text{RESET}}$  will be pulled high as  $V_{CC}$  decays toward 0. The voltage where this occurs depends on the pull-up resistor value and the voltage to which it is connected.

**Benefits of Highly Accurate Reset Threshold**

Most  $\mu$ P supervisor ICs have reset threshold voltages between 5% and 10% below the value of nominal supply voltages. This ensures a reset will not occur within 5% of the nominal supply, but will occur when the supply is 10% below nominal.

When using ICs rated at only the nominal supply  $\pm 5\%$ , this leaves a zone of uncertainty where the supply is between 5% and 10% low, and where the reset may or may not be asserted.

The G67\_463/G67\_308 use highly accurate circuitry to ensure that reset is asserted close to the 5% limit, and long before the supply has declined to 10% below nominal.

Package Information

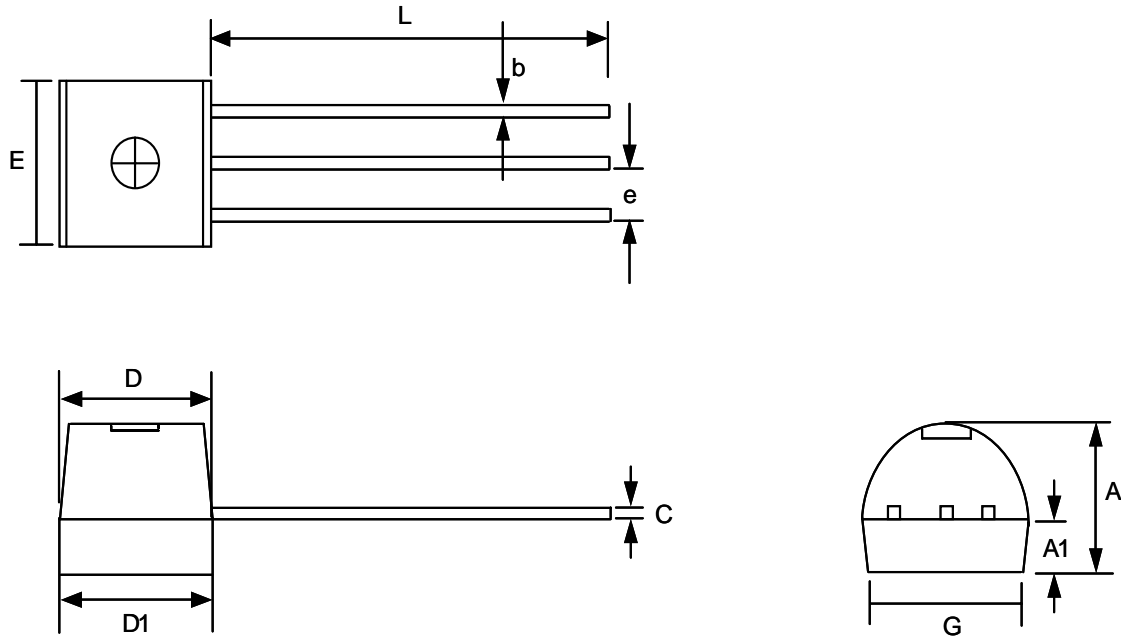

TO-92 (TD) Package

SYMBOL	MILLIMETER		INCH	
	MIN	MAX	MIN	MAX
A	3.35	3.86	0.132	0.152
A1	1.0414	1.55	0.041	0.061
b	0.254	0.508	0.010	0.020
E	4.34	4.85	0.171	0.191
C	0.254	0.508	0.010	0.020
L	14.53	15.04	0.572	0.592
e	1.143	1.397	0.045	0.055
G	3.683	4.191	0.145	0.165
D	4.29	4.80	0.169	0.189
D1	4.34	4.85	0.171	0.191

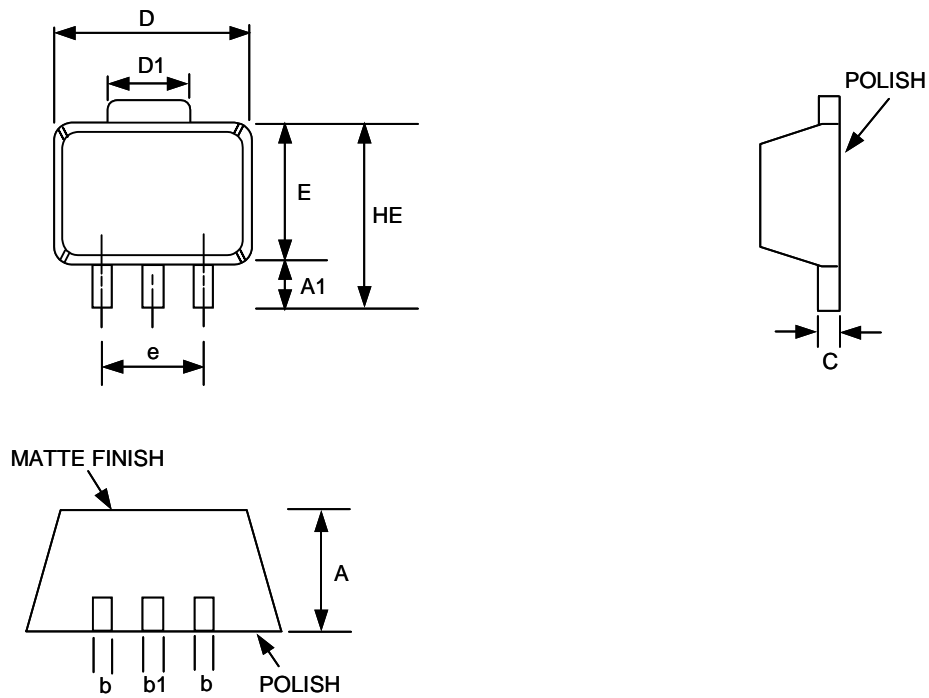

**SOT-89 (T2) Package**

SYMBOL	DIMENSIONS IN MILLIMETER			DIMENSIONS IN INCH		
	MIN	NOM	MAX	MIN	NOM	MAX
A	1.40	1.50	1.60	0.055	0.059	0.063
A1	0.80	1.04	-----	0.031	0.041	-----
b	0.36	0.42	0.48	0.014	0.016	0.018
b1	0.41	0.47	0.53	0.016	0.018	0.020
C	0.38	0.40	0.43	0.014	0.015	0.017
D	4.40	4.50	4.60	0.173	0.177	0.181
D1	1.40	1.60	1.75	0.055	0.062	0.069
HE	-----	-----	4.25	-----	-----	0.167
E	2.40	2.50	2.60	0.094	0.098	0.102
e	2.90	3.00	3.10	0.114	0.118	0.122

**Package Information**

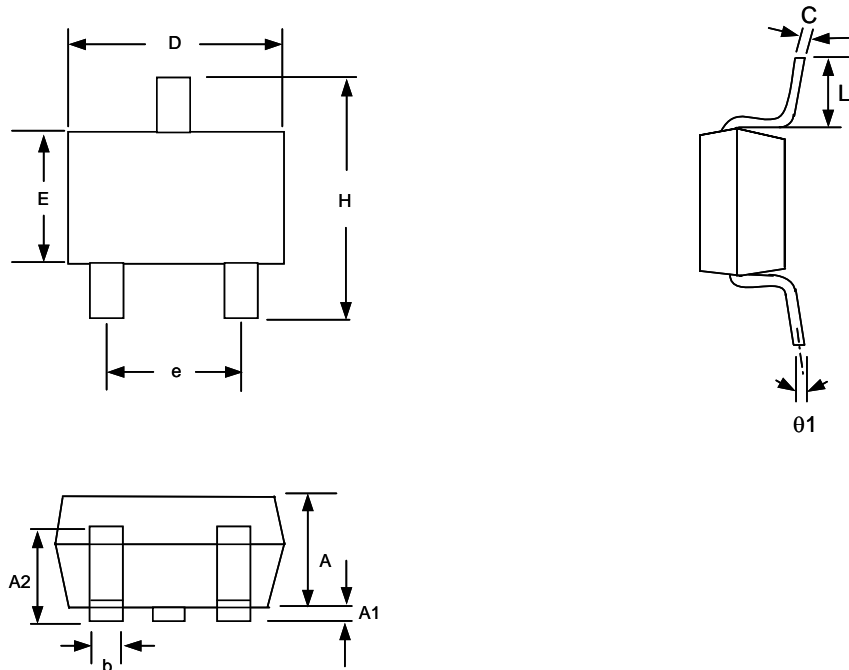

**SOT-23 (T7) Package**

**Note:**

- 1.Package body sizes exclude mold flash protrusions or gate burrs
- 2.Tolerance  $\pm 0.1000$  mm (4mil) unless otherwise specified
- 3.Coplanarity: 0.1000mm
- 4.Dimension L is measured in gage plane

SYMBOL	DIMENSIONS IN MILLIMETER		
	MIN	NOM	MAX
A	1.00	1.10	1.30
A1	0.00	-----	0.10
A2	0.70	0.80	0.90
b	0.35	0.40	0.50
C	0.10	0.15	0.25
D	2.70	2.90	3.10
E	1.40	1.60	1.80
e	-----	1.90(TYP)	-----
H	2.60	2.80	3.00
L	0.37	-----	-----
$\theta 1$	1°	5°	9°

**Taping Specification**

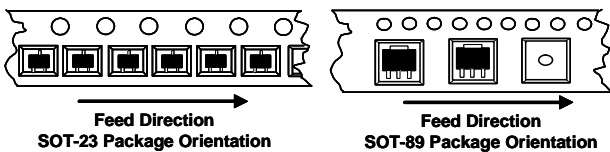

PACKAGE	Q'TY/REEL	Q'TY/BY BAG
TO-92	-----	2,000 ea
SOT-89	1,000 ea	-----
SOT-23	3,000 ea	-----

GMT Inc. does not assume any responsibility for use of any circuitry described, no circuit patent licenses are implied and GMT Inc. reserves the right at any time without notice to change said circuitry and specifications.