

# GB30RF60K

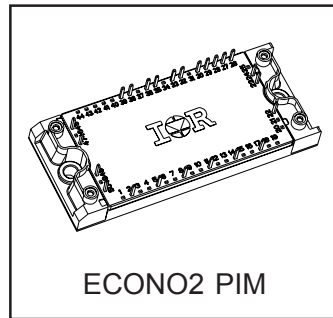
## IGBT PIM MODULE

### Features

- Low  $V_{CE(on)}$  Non Punch Through IGBT Technology
- Low Diode  $V_F$
- 10 $\mu$ s Short Circuit Capability
- Square RBSOA
- HEXFRED Antiparallel Diode with Ultrasoft Reverse Recovery Characteristics
- Positive  $V_{CE(on)}$  Temperature Coefficient
- Ceramic DBC Substrate
- Low Stray Inductance Design
- TOTALLY LEAD-FREE

### Benefits

- Benchmark Efficiency for Motor Control
- Rugged Transient Performance
- Low EMI, Requires Less Snubbing
- Direct Mounting to Heatsink
- PCB Solderable Terminals
- Low Junction to Case Thermal Resistance

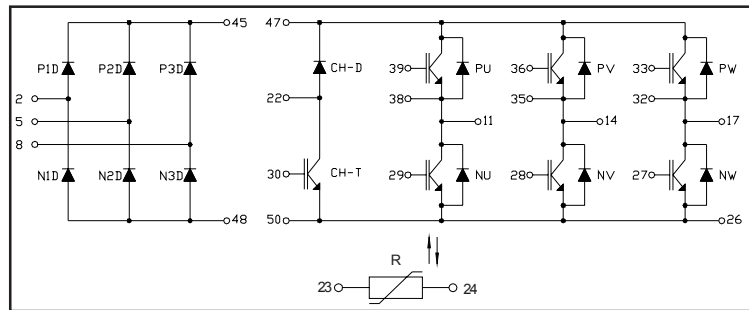


$$V_{CES} = 600V$$

$$I_C = 27A @ T_C = 80^\circ C$$

$$t_{sc} > 10\mu s @ T_J = 150^\circ C$$

$$V_{CE(on)} \text{ typ.} = 2.04V$$



### Absolute Maximum Ratings

	Parameter	Symbol	Test Conditions		Ratings	Units
Inverter	Collector-to-Emitter Voltage	$V_{CES}$			600	V
	Gate-to-Emitter Voltage	$V_{GES}$			$\pm 20$	
	Collector Current	$I_C$	Continuous	25°C / 80°C	50 / 27	A
			Pulsed	25°C	100	
	Diode Maximum Forward Current	$I_{FM}$		25°C	100	
Power Dissipation	$P_D$	One IGBT	25°C	129	W	
Input Rectifier	Repetitive Peak Reverse Voltage	$V_{RRM}$			800	V
	Average Output Current	$I_{F(AV)}$	50/60Hz sine pulse	80°C	30	A
	Surge Current (Non Repetitive)	$I_{FSM}$	Rated $V_{RRM}$ applied, 10ms,		310	
	$I^2 t$ (Non Repetitive)	$I^2 t$	sine pulse		525	A <sup>2</sup> s
Brake	Collector-to-Emitter Voltage	$V_{CES}$			600	V
	Gate-to-Emitter Voltage	$V_{GES}$			$\pm 20$	
	Collector Current	$I_C$	Continuous	25°C / 80°C	30 / 20	A
			Pulsed	25°C	60	
	Power Dissipation	$P_D$	One IGBT	25°C	100	W
	Repetitive Peak Reverse Voltage	$V_{RRM}$			600	V
	Maximum Operating Junction Temperature	$T_J$			150	°C
	Storage Temperature Range	$T_{STG}$			-40 to +125	
Isolation Voltage	$V_{ISOL}$	AC (1 min)			2500	V

### Thermal and Mechanical Characteristics

Parameter	Symbol	Min	Typical	Maximum	Units
Junction-to-Case Inverter IGBT Thermal Resistance	$R_{\theta JC}$	-	-	0.97	°C/W
Junction-to-Case Inverter FRED Thermal Resistance		-	-	1.42	
Junction-to-Case Brake DIODE Thermal Resistance		-	-	2.44	
Junction-to-Case Brake IGBT Thermal Resistance		-	-	1.25	
Junction-to-Case Input Rectifier Thermal Resistance		-	-	1.03	
Case-to-Sink, flat, greased surface	$R_{\theta CS}$	-	0.05	-	
Mounting Torque (M5)		2.7	-	3.3	Nm
Weight			170		g

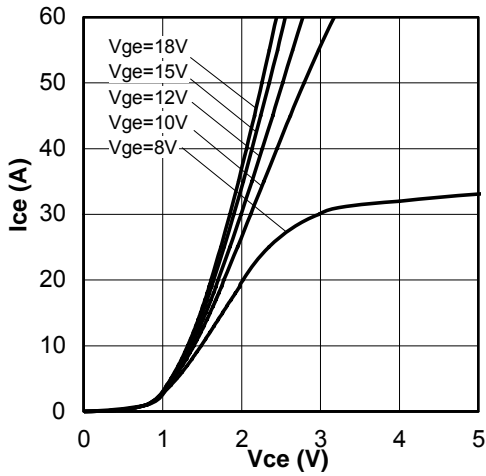
### Electrical Characteristics @ T<sub>J</sub> = 25°C (unless otherwise specified)

		Parameter	Min.	Typ.	Max.	Units	Conditions
Inverter	BV(CES)	Collector-to-Emitter Breakdown Voltage	600	-	-	V	V <sub>GE</sub> = 0 I <sub>C</sub> = 500μA
IGBT	ΔV(BR)CES/ΔT <sub>J</sub>	Temp. Coefficient of Breakdown Voltage	-	0.7	-	V/°C	V <sub>GE</sub> = 0 I <sub>C</sub> = 1mA (25°C - 125°C)
	V <sub>CE(ON)</sub>	Collector-to-Emitter Voltage	-	2.04	2.65	V	I <sub>C</sub> = 30A V <sub>GE</sub> = 15V
			-	2.60	3.62		I <sub>C</sub> = 50A V <sub>GE</sub> = 15V
			-	2.31	2.80		I <sub>C</sub> = 30A V <sub>GE</sub> = 15V T <sub>J</sub> = 125°C
			-	3.01	2.77		I <sub>C</sub> = 50A V <sub>GE</sub> = 15V T <sub>J</sub> = 125°C
	V <sub>GE(th)</sub>	Gate Threshold Voltage	3.5	-	5.5		V <sub>CE</sub> = V <sub>GE</sub> I <sub>C</sub> = 250μA
	ΔV <sub>GE(th)</sub> /ΔT <sub>J</sub>	Threshold Voltage temp. coefficient	-	-10	-	mV/°C	V <sub>CE</sub> = V <sub>GE</sub> I <sub>C</sub> = 1mA (25°C-125°C)
	I <sub>CES</sub>	Zero Gate Voltage Collector Current	-	-	100	μA	V <sub>GE</sub> = 0 V <sub>CE</sub> = 600V
			-	400	-		V <sub>GE</sub> = 0 V <sub>CE</sub> = 600V T <sub>J</sub> = 125°C
	I <sub>GES</sub>	Gate-to-Emitter Leakage Current	-	-	±200	nA	V <sub>GE</sub> = ±20V
	Q <sub>G</sub>	Total Gate Charge (turn-on)	-	105	158		I <sub>C</sub> = 30A
	Q <sub>GE</sub>	Gate-to-Emitter Charge (turn-on)	-	14	21	nC	V <sub>CC</sub> = 300V
	Q <sub>GC</sub>	Gate-to-Collector Charge (turn-on)	-	51	76		V <sub>GE</sub> = 15V
	E <sub>ON</sub>	Turn-On Switching Loss	-	491	737	μJ	I <sub>C</sub> = 30A V <sub>CC</sub> = 300V
	E <sub>OFF</sub>	Turn-Off Switching Loss	-	223	335		V <sub>GE</sub> = 15V R <sub>G</sub> = 22Ω L = 200μH
	E <sub>TOT</sub>	Total Switching Loss	-	714	1072		T <sub>J</sub> = 25°C <sup>1</sup>
	E <sub>ON</sub>	Turn-On Switching Loss	-	613	920	μJ	I <sub>C</sub> = 30A V <sub>CC</sub> = 300V
	E <sub>OFF</sub>	Turn-Off Switching Loss	-	417	626		V <sub>GE</sub> = 15V R <sub>G</sub> = 22Ω L = 200μH
	E <sub>TOT</sub>	Total Switching Loss	-	1030	1546		T <sub>J</sub> = 125°C <sup>1</sup>
	t <sub>d(on)</sub>	Turn-On delay time	-	132	198	ns	I <sub>C</sub> = 30A V <sub>CC</sub> = 300V
	t <sub>r</sub>	Rise time	-	33	50		V <sub>GE</sub> = 15V R <sub>G</sub> = 22Ω L = 200μH
	t <sub>d(off)</sub>	Turn-Off delay time	-	153	229		T <sub>J</sub> = 125°C
	t <sub>f</sub>	Fall time	-	88	132		
C <sub>ies</sub>	Input Capacitance	-	1834	2751	pF	V <sub>GE</sub> = 0	
C <sub>oes</sub>	Output Capacitance	-	459	690		V <sub>CC</sub> = 30V	
C <sub>res</sub>	Reverse Transfer Capacitance	-	54	81		f = 1Mhz	
RBSOA	Reverse Bias Safe Operating Area	FULL SQUARE				T <sub>J</sub> = 150°C I <sub>C</sub> = 60A R <sub>G</sub> = 22Ω V <sub>GE</sub> = 15V to 0	
SCSOA	Short Circuit Safe Operating Area	10	-	-	μs	I <sub>P</sub> = 220A to 310A V <sub>CC</sub> = 300V R <sub>G</sub> = 47Ω V <sub>GE</sub> = 15V to 0	
Inverter Diode	I <sub>rr</sub>	Diode Peak Rev. Recovery Current	-	43	-	A	T <sub>J</sub> = 125°C
			-	-	-		V <sub>CC</sub> = 300V I <sub>F</sub> = 30A L = 200μH
			-	-	-		V <sub>GE</sub> = 15V R <sub>G</sub> = 22Ω
			-	-	-		
	V <sub>FM</sub>	Diode Forward Voltage Drop	-	1.31	1.81	V	I <sub>F</sub> = 30A
-			1.52	2.40	I <sub>F</sub> = 50A		
-			1.25	1.68	I <sub>F</sub> = 30A T <sub>J</sub> = 125°C		
-			1.47	2.14	I <sub>F</sub> = 50A T <sub>J</sub> = 125°C		

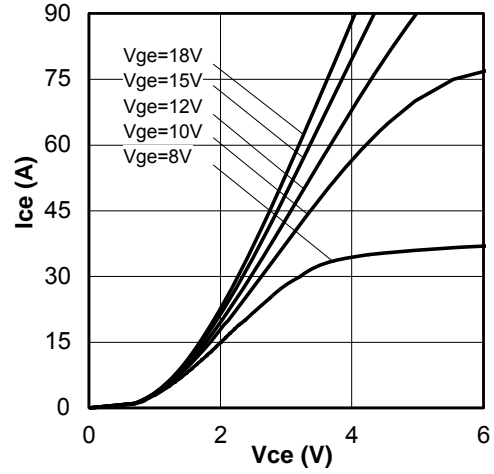
**Electrical Characteristics @ T<sub>J</sub> = 25°C (unless otherwise specified)**

		Parameter	Min.	Typ.	Max.	Units	Conditions
Input Rectifier	V <sub>FM</sub>	Maximum Forward Voltage Drop	-	-	1.50	V	I <sub>F</sub> = 30A
	I <sub>RM</sub>	Maximum Reverse Leakage Current	-	-	0.2	mA	T <sub>J</sub> = 25°C V <sub>R</sub> = 800V
			-	-	1		T <sub>J</sub> = 150°C V <sub>R</sub> = 800V
	r <sub>T</sub>	Forward Slope Resistance	-	8.8	-	mΩ	T <sub>J</sub> = 150°C
V <sub>F(TO)</sub>	Conduction Thresold Voltage	-	0.79	-	V		
Brake IGBT	BV <sub>(CES)</sub>	Collector-to-Emitter Breakdown Voltage	600	-	-	V	V <sub>GE</sub> = 0 I <sub>C</sub> = 500μA
	ΔV <sub>(BR)CES/ΔT<sub>J</sub></sub>	Temp. Coefficient of Breakdown Voltage	-	0.6	-	V/°C	V <sub>GE</sub> = 0 I <sub>C</sub> = 1mA (25°C - 125°C)
	V <sub>CE(ON)</sub>	Collector-to-Emitter Voltage	-	2.07	2.24	V	I <sub>C</sub> = 20A V <sub>GE</sub> = 15V
			-	2.51	2.71		I <sub>C</sub> = 30A V <sub>GE</sub> = 15V
			-	2.49	2.72		I <sub>C</sub> = 20A V <sub>GE</sub> = 15V T <sub>J</sub> = 125°C
			-	3.06	3.47		I <sub>C</sub> = 30A V <sub>GE</sub> = 15V T <sub>J</sub> = 125°C
	V <sub>GE(th)</sub>	Gate Threshold Voltage	4	-	6		V <sub>CE</sub> = V <sub>GE</sub> I <sub>C</sub> = 250μA
	ΔV <sub>GE(th)/ΔT<sub>J</sub></sub>	Thresold Voltage temp. coefficient	-	-10	-	mV/°C	V <sub>CE</sub> = V <sub>GE</sub> I <sub>C</sub> = 1mA (25°C-125°C)
	I <sub>CES</sub>	Zero Gate Voltage Collector Current	-	-	100	μA	V <sub>GE</sub> = 0 V <sub>CE</sub> = 600V
			-	250	-		V <sub>GE</sub> = 0 V <sub>CE</sub> = 600V T <sub>J</sub> = 125°C
	I <sub>GES</sub>	Gate-to-Emitter Leakage Current	-	-	±200	nA	V <sub>GE</sub> = ±20V
	Q <sub>G</sub>	Total Gate Charge (turn-on)	-	48	72	nC	I <sub>C</sub> = 15A
	Q <sub>GE</sub>	Gate-to-Emitter Charge (turn-on)	-	11	16		V <sub>CC</sub> = 300V
	Q <sub>GC</sub>	Gate-to-Collector Charge (turn-on)	-	30	44		V <sub>GE</sub> = 15V
	E <sub>ON</sub>	Turn-On Switching Loss	-	176	264	μJ	I <sub>C</sub> = 15A V <sub>CC</sub> = 300V
	E <sub>OFF</sub>	Turn-Off Switching Loss	-	137	207		V <sub>GE</sub> = 15V R <sub>G</sub> = 22Ω L = 200μH
	E <sub>TOT</sub>	Total Switching Loss	-	313	471		T <sub>J</sub> = 25°C <sup>1</sup>
	E <sub>ON</sub>	Turn-On Switching Loss	-	235	353	μJ	I <sub>C</sub> = 15A V <sub>CC</sub> = 300V
	E <sub>OFF</sub>	Turn-Off Switching Loss	-	276	416		V <sub>GE</sub> = 15V R <sub>G</sub> = 22Ω L = 200μH
	E <sub>TOT</sub>	Total Switching Loss	-	512	768		T <sub>J</sub> = 125°C <sup>1</sup>
t <sub>d(on)</sub>	Turn-On delay time	-	87	131	ns	I <sub>C</sub> = 15A V <sub>CC</sub> = 300V	
t <sub>r</sub>	Risetime	-	24	36		V <sub>GE</sub> = 15V R <sub>G</sub> = 22Ω L = 200μH	
t <sub>d(off)</sub>	Turn-Off delay time	-	112	169		T <sub>J</sub> = 125°C	
t <sub>f</sub>	Fall time	-	115	172			
C <sub>ies</sub>	Input Capacitance	-	901	1352	pF	V <sub>GE</sub> = 0	
		-	263	395		V <sub>CC</sub> = 30V	
		-	29	44		f = 1Mhz	
RBSOA	Reverse Bias Safe Operating Area	FULLSQUARE				T <sub>J</sub> = 150°C I <sub>C</sub> = 20A R <sub>G</sub> = 22Ω V <sub>GE</sub> = 15V to 0	
SCSOA	Short Circuit Safe Operating Area	10	-	-	μs	I <sub>P</sub> = 180A to 280A V <sub>CC</sub> = 300V R <sub>G</sub> = 47Ω V <sub>GE</sub> = 15V to 0	
Brake Diode	I <sub>rr</sub>	Diode Peak Rev. Recovery Current	-	28	-	A	V <sub>CC</sub> = 300V I <sub>F</sub> = 15A L = 200μH V <sub>GE</sub> = 15V to 0 R <sub>G</sub> = 22Ω
	V <sub>FM</sub>	Diode Forward Voltage Drop	-	1.61	1.71	V	I <sub>F</sub> = 20A
			-	1.79	1.99		I <sub>F</sub> = 30A
			-	1.57	1.66		I <sub>F</sub> = 20A T <sub>J</sub> = 125°C
-			1.73	1.83	I <sub>F</sub> = 30A T <sub>J</sub> = 125°C		
NTC	R	Resistance	-	5000	-	Ω	T <sub>J</sub> = 25°C
			-	4933	-		T <sub>J</sub> = 100°C
	B	B Value	-	3375	-	K	T <sub>J</sub> = 25°C / 50°C

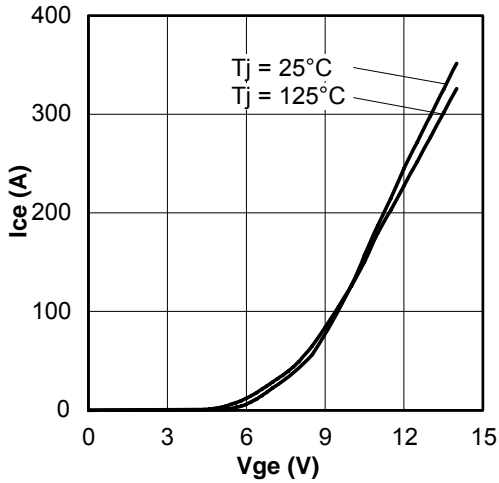
<sup>1</sup> Energy Losses include "tail" and diode reverse recovery



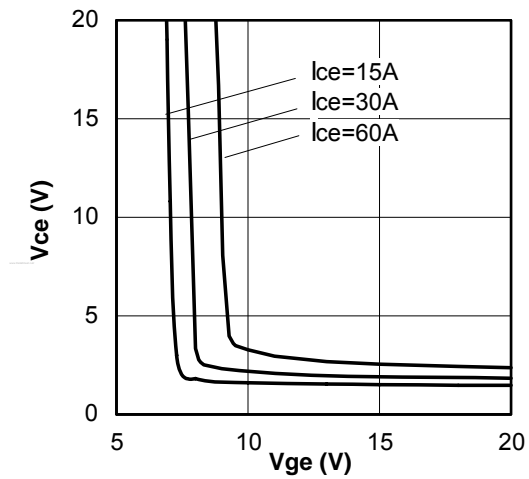
**Fig. 1 - Typ. IGBT Output Characteristics**  
 $T_J = 25^\circ\text{C}$ ;  $t_p = 80\mu\text{s}$



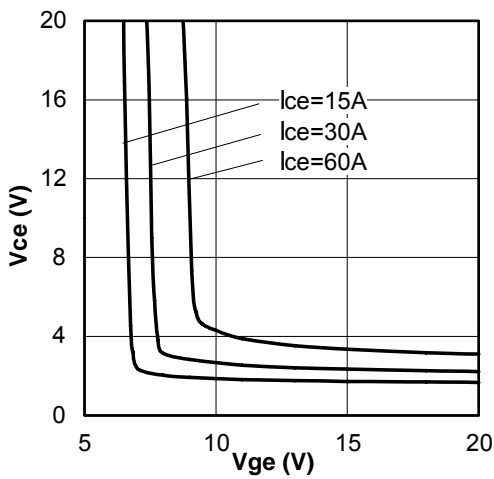
**Fig. 2 - Typ. IGBT Output Characteristics**  
 $T_J = 125^\circ\text{C}$ ;  $t_p = 80\mu\text{s}$



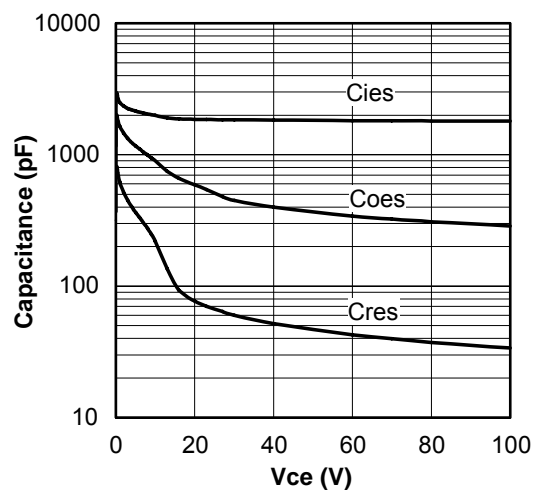
**Fig. 3 - Typ. Transfer Characteristics**  
 $V_{CE} = 50\text{V}$ ;  $t_p = 10\mu\text{s}$



**Fig. 4 - Typical  $V_{CE}$  vs.  $V_{GE}$**   
 $T_J = 25^\circ\text{C}$

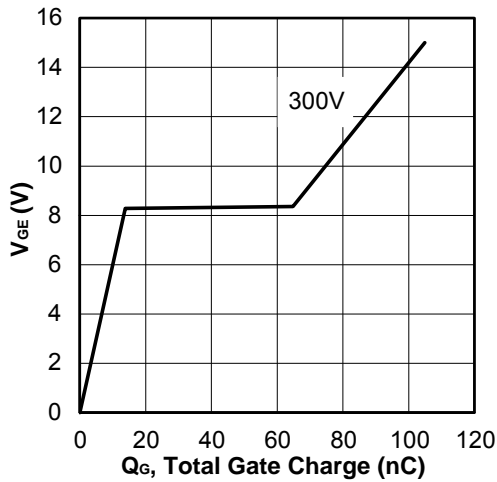


**Fig. 5 - Typical  $V_{CE}$  vs.  $V_{GE}$**   
 $T_J = 125^\circ\text{C}$

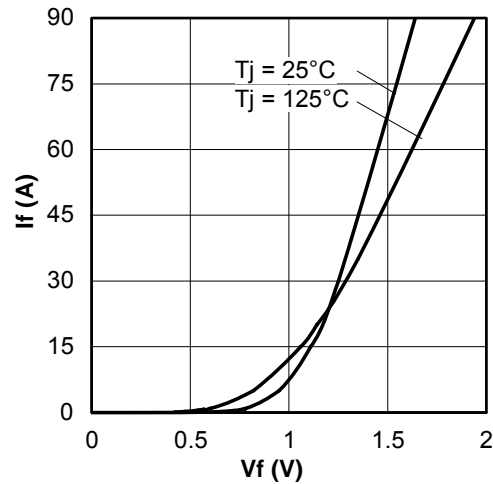


**Fig. 6- Typ. Capacitance vs.  $V_{CE}$**   
 $V_{GE} = 0$ ;  $f = 1\text{MHz}$

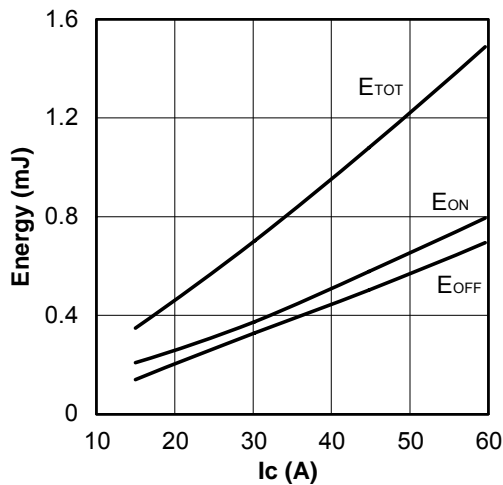
**Inverter**



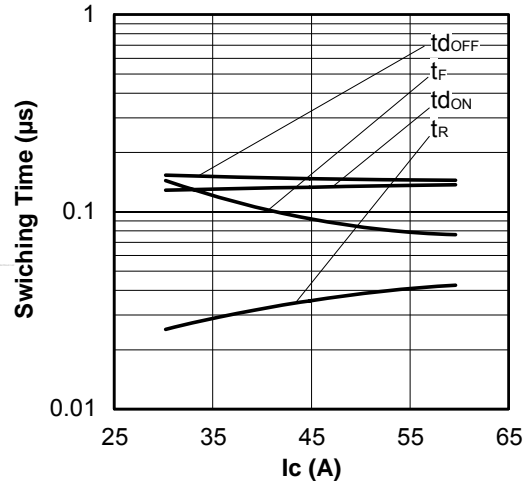
**Fig. 7 - Typical Gate Charge vs.  $V_{GE}$**   
 $I_{CE} = 30A$



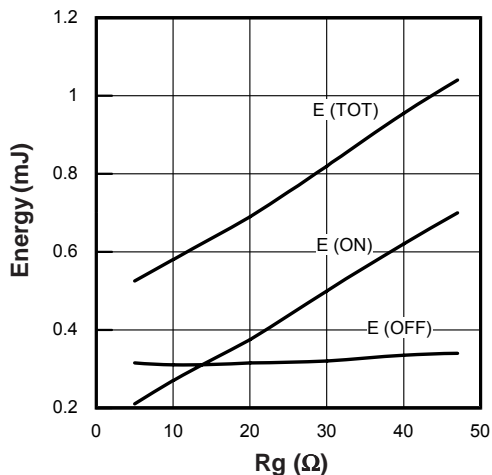
**Fig. 8 - Typ. Diode Forward Characteristics**  
 $t_p = 80\mu s$



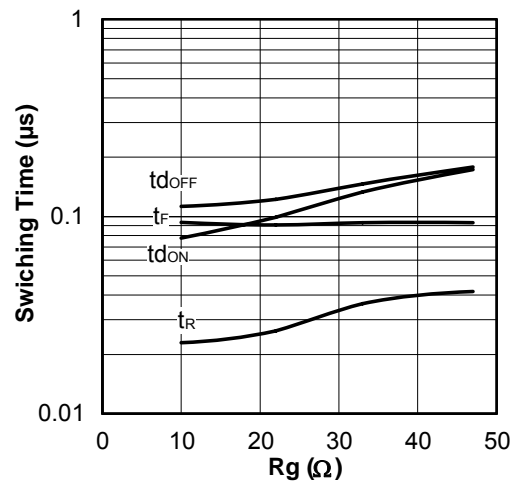
**Fig. 9 - Typ. Energy Loss vs.  $I_C$**   
 $T_J = 125^\circ C$ ;  $L = 200\mu H$ ;  $V_{CE} = 300V$ ;  $R_G = 22\Omega$ ;  $V_{GE} = 15V$



**Fig. 10 - Typ. Switching Time vs.  $I_C$**   
 $T_J = 125^\circ C$ ;  $L = 200\mu H$ ;  $V_{CE} = 300V$ ;  $R_G = 22\Omega$ ;  $V_{GE} = 15V$

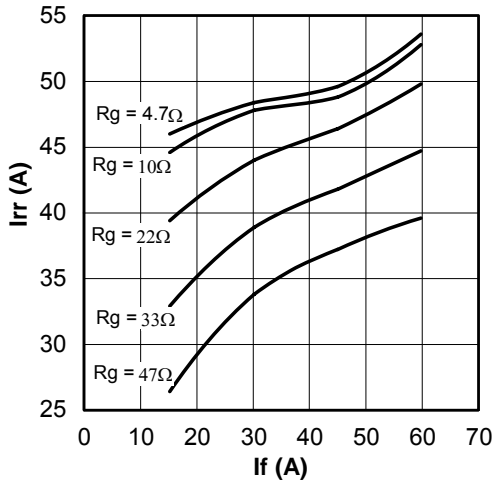


**Fig. 11 - Typ. Energy Loss vs.  $R_G$**   
 $T_J = 125^\circ C$ ;  $L = 200\mu H$ ;  $V_{CE} = 300V$ ;  $I_{CE} = 30A$ ;  $V_{GE} = 15V$

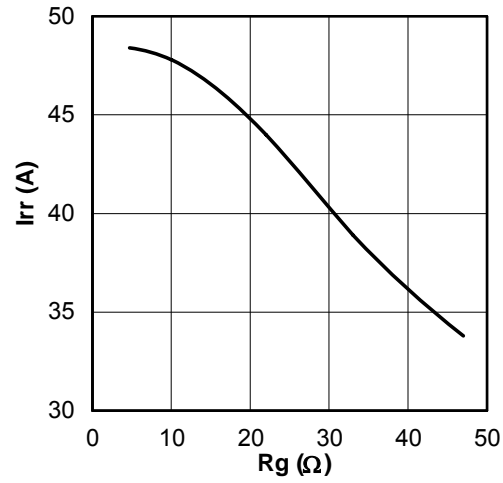


**Fig. 12 - Typ. Switching Time vs.  $R_G$**   
 $T_J = 125^\circ C$ ;  $L = 200\mu H$ ;  $V_{CE} = 300V$ ;  $I_{CE} = 30A$ ;  $V_{GE} = 15V$

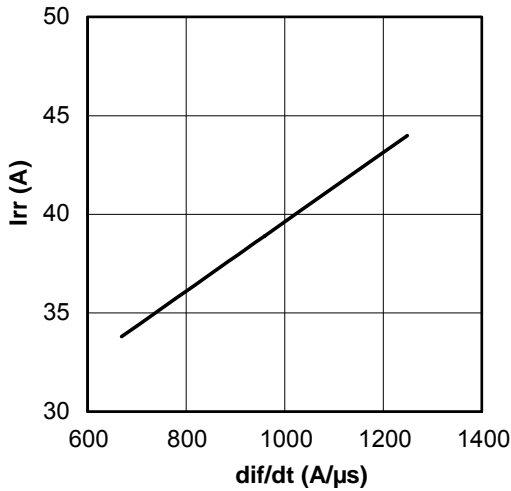
## Inverter



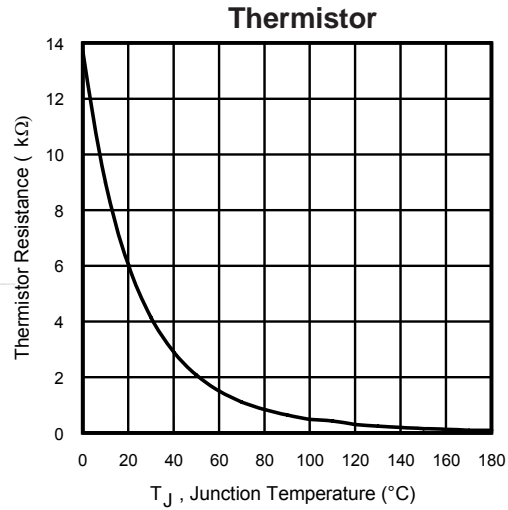
**Fig. 13** - Typical Diode  $I_{RR}$  vs.  $I_F$   
 $T_J = 125^\circ\text{C}$



**Fig. 14** - Typical Diode  $I_{RR}$  vs.  $R_g$   
 $T_J = 125^\circ\text{C}$ ;  $I_F = 30\text{A}$

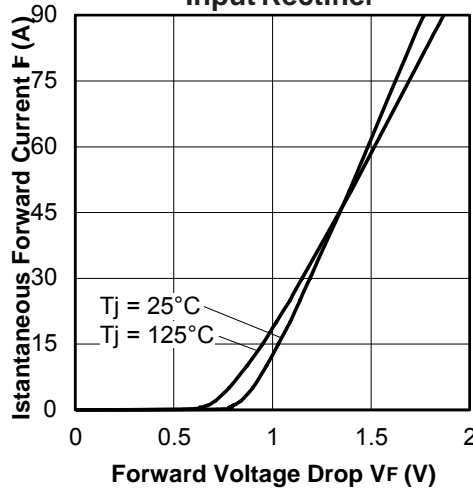


**Fig. 15** - Typical Diode  $I_{RR}$  vs.  $di_F/dt$   
 $V_{CC} = 300\text{V}$ ;  $V_{GE} = 15\text{V}$ ;  $I_{CE} = 30\text{A}$ ;  $T_J = 125^\circ\text{C}$



**Fig. 16** - Thermistor Resistance vs. Temperature

## Input Rectifier



**Fig. 17** - Typ. Diode Forward Characteristics  
 $t_p = 80\mu\text{s}$

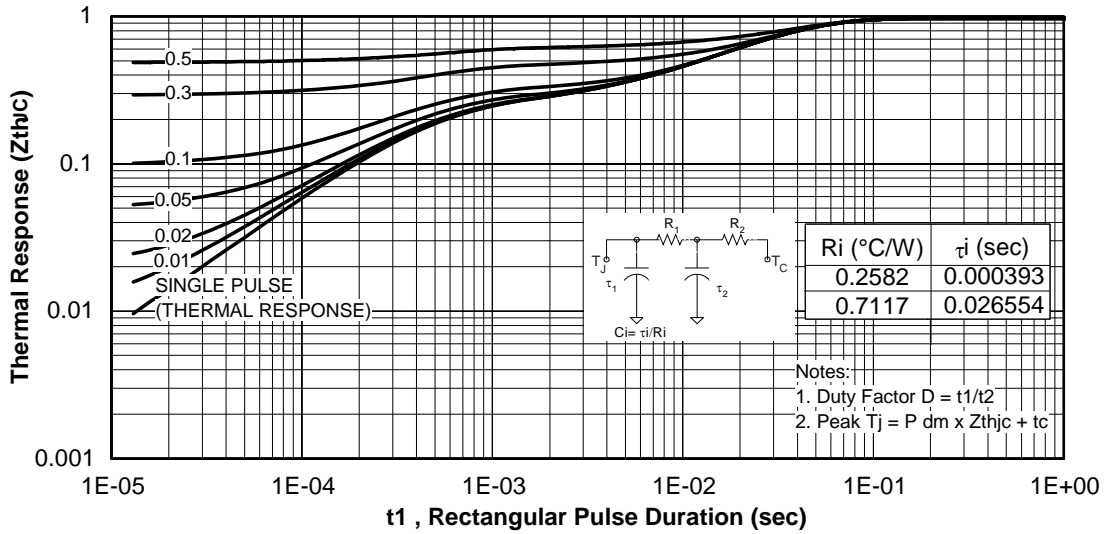


Fig 18. Maximum Transient Thermal Impedance, Junction-to-Case (IGBT)

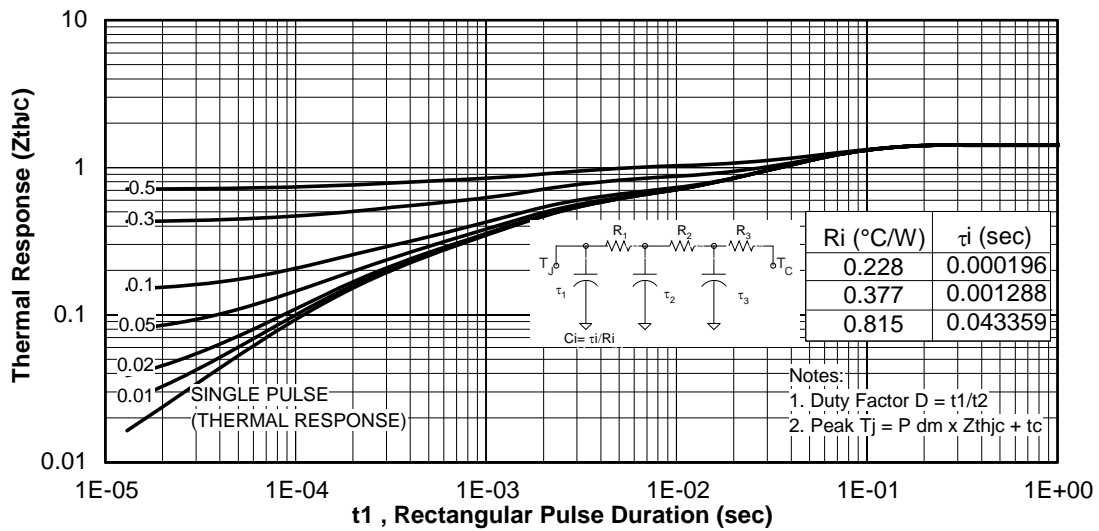
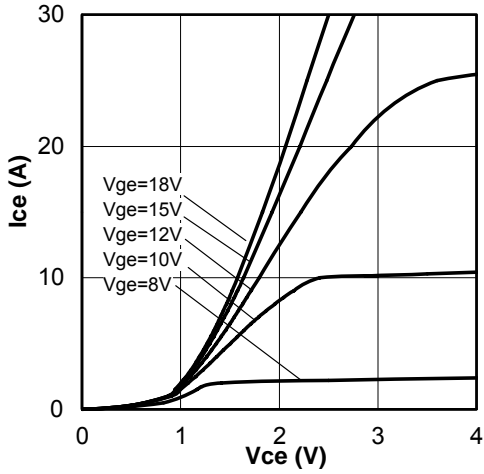
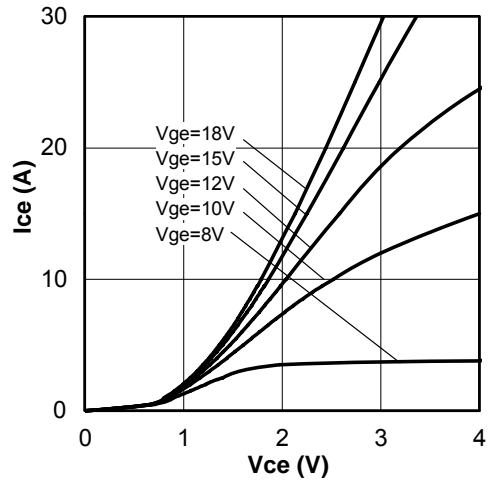


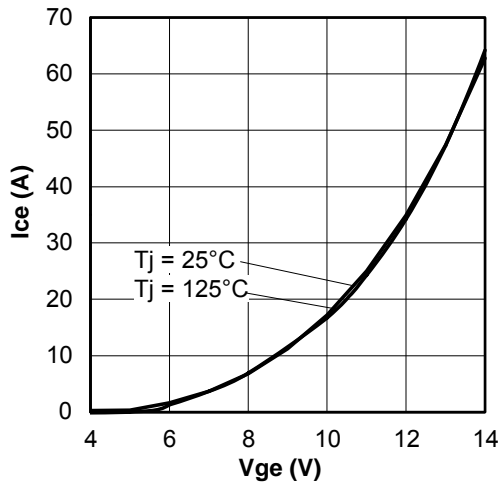
Fig 19. Maximum Transient Thermal Impedance, Junction-to-Case (DIODE)



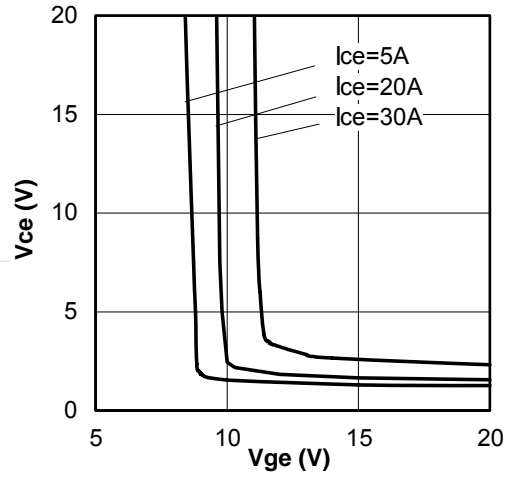
**Fig. 20** - Typ. IGBT Output Characteristics  
 $T_J = 25^\circ\text{C}$ ;  $t_p = 80\mu\text{s}$



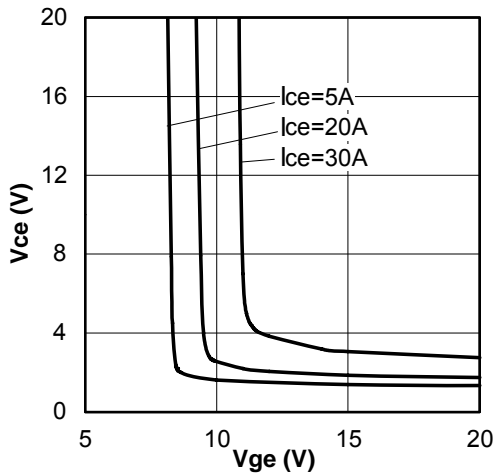
**Fig. 21** - Typ. IGBT Output Characteristics  
 $T_J = 125^\circ\text{C}$ ;  $t_p = 80\mu\text{s}$



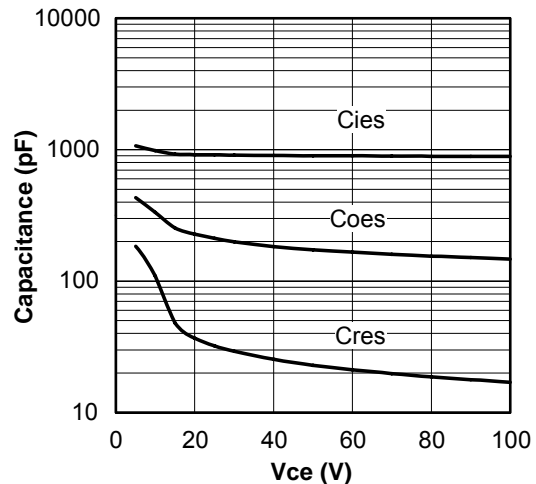
**Fig. 22** - Typ. Transfer Characteristics  
 $V_{CE} = 50\text{V}$ ;  $t_p = 10\mu\text{s}$



**Fig. 23** - Typical  $V_{CE}$  vs.  $V_{GE}$   
 $T_J = 25^\circ\text{C}$



**Fig. 24** - Typical  $V_{CE}$  vs.  $V_{GE}$   
 $T_J = 125^\circ\text{C}$



**Fig. 25** - Typ. Capacitance vs.  $V_{CE}$   
 $V_{GE} = 0$ ;  $f = 1\text{MHz}$



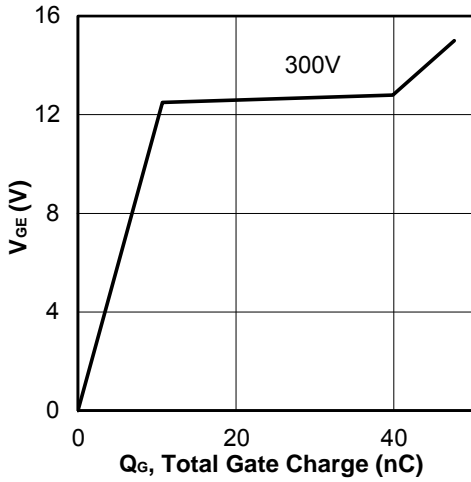


Fig. 26 - Typical Gate Charge vs.  $V_{GE}$   
 $I_{CE} = 15A$

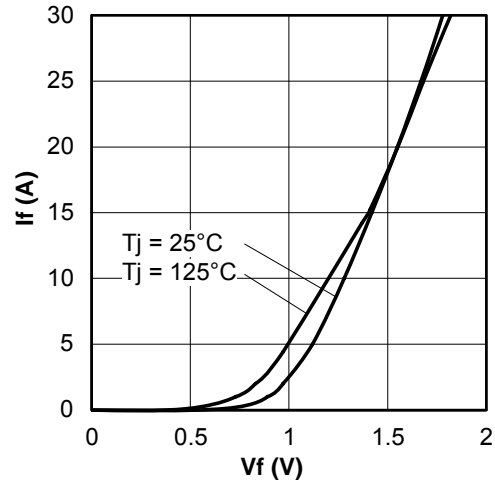


Fig. 27 - Typ. Diode Forward Characteristics  
 $t_p = 80\mu s$

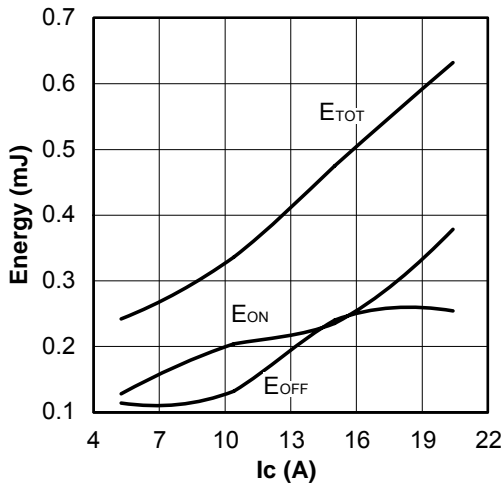


Fig. 28 - Typ. Energy Loss vs.  $I_C$   
 $T_J = 125^\circ C$ ;  $L = 200\mu H$ ;  $V_{CE} = 300V$ ,  $R_G = 22\Omega$ ;  $V_{GE} = 15V$

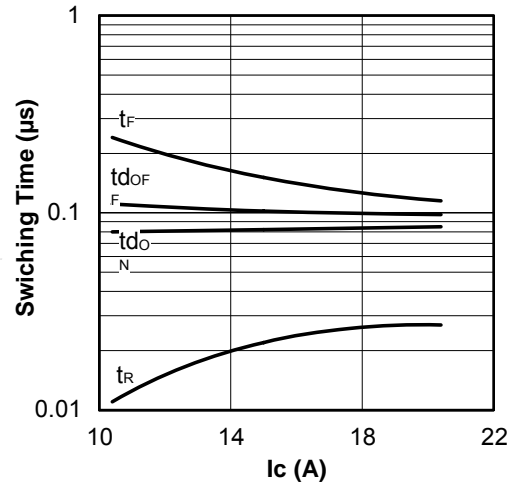


Fig. 29 - Typ. Switching Time vs.  $I_C$   
 $T_J = 125^\circ C$ ;  $L = 200\mu H$ ;  $V_{CE} = 300V$ ,  $R_G = 22\Omega$ ;  $V_{GE} = 15V$

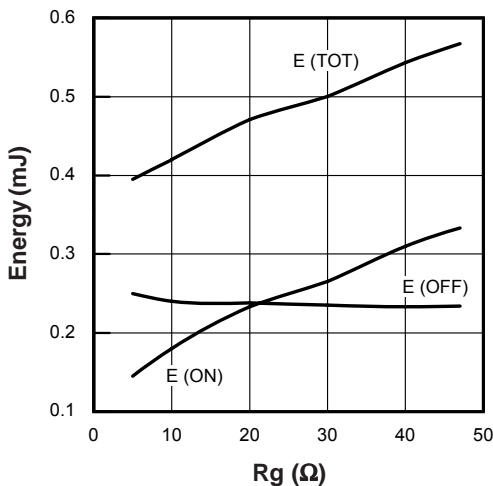


Fig. 30 - Typ. Energy Loss vs.  $R_G$   
 $T_J = 125^\circ C$ ;  $L = 200\mu H$ ;  $V_{CE} = 300V$ ,  $I_{CE} = 15A$ ;  $V_{GE} = 15V$   
Document Number: 94479

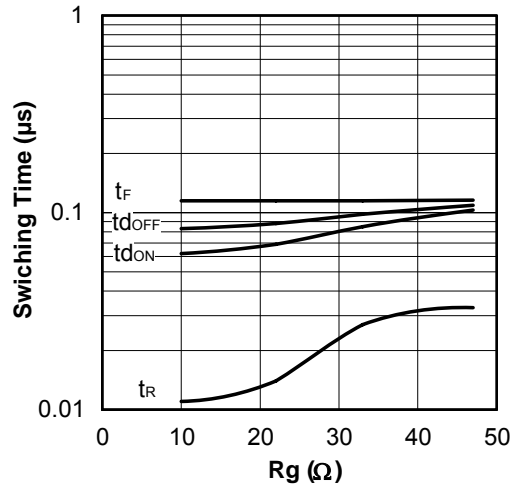


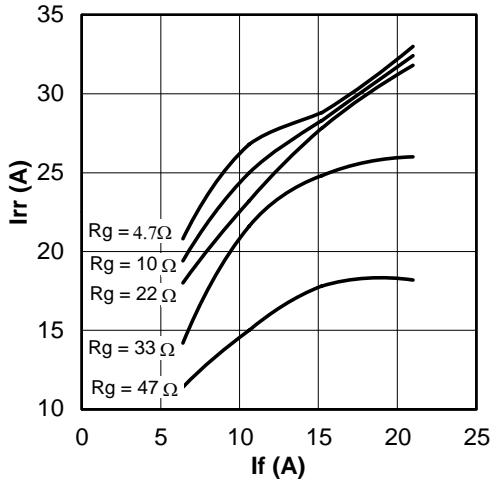
Fig. 31 - Typ. Switching Time vs.  $R_G$   
 $T_J = 125^\circ C$ ;  $L = 200\mu H$ ;  $V_{CE} = 300V$ ,  $I_{CE} = 15A$ ;  $V_{GE} = 15V$

# GB30RF60K

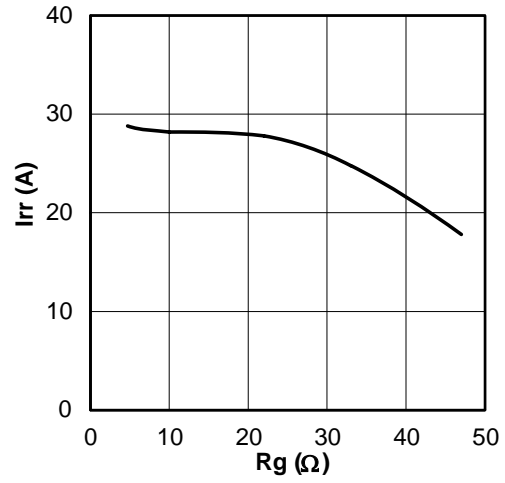
Bulletin I27303 01/07

Brake

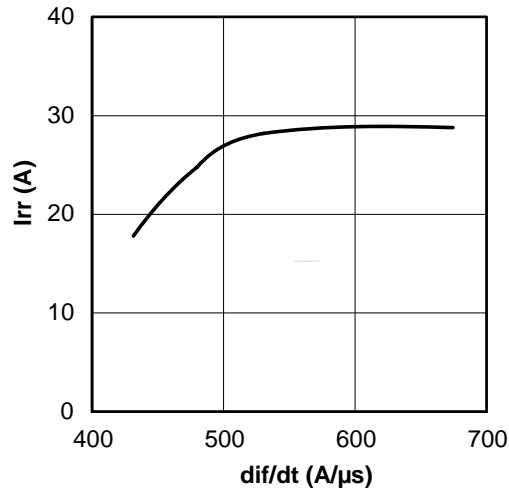
International  
IOR Rectifier



**Fig. 32** - Typical Diode  $I_{RR}$  vs.  $I_F$   
 $T_J = 125^\circ\text{C}$



**Fig. 33** - Typical Diode  $I_{RR}$  vs.  $R_G$   
 $T_J = 125^\circ\text{C}$ ;  $I_F = 15\text{A}$



**Fig. 34** - Typical Diode  $I_{RR}$  vs.  $di_F/dt$   
 $V_{CC} = 300\text{V}$ ;  $V_{GE} = 15\text{V}$ ;  $I_{CE} = 15\text{A}$ ;  $T_J = 125^\circ\text{C}$

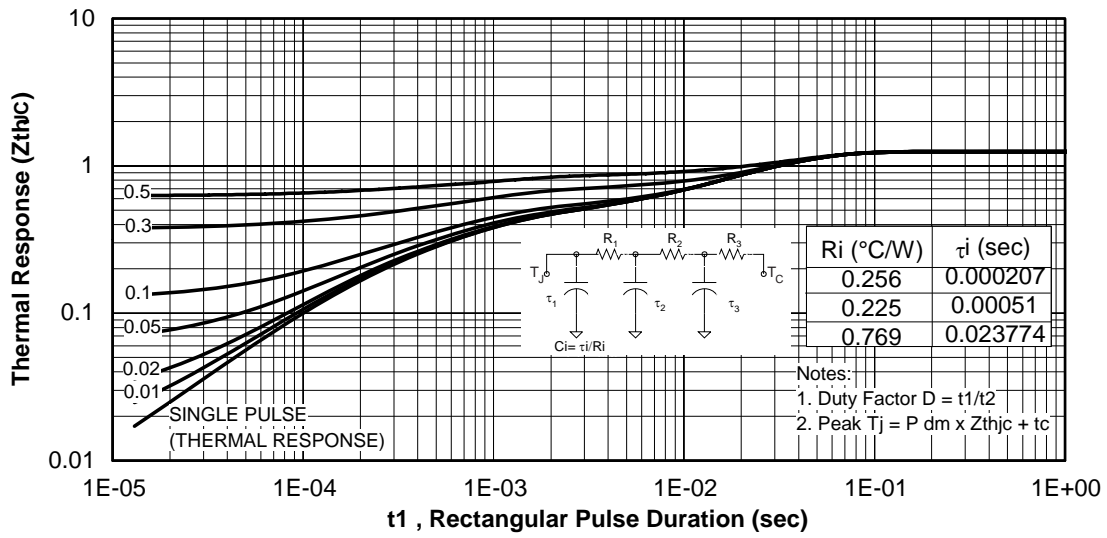


Fig 35. Maximum Transient Thermal Impedance, Junction-to-Case (Brake IGBT)

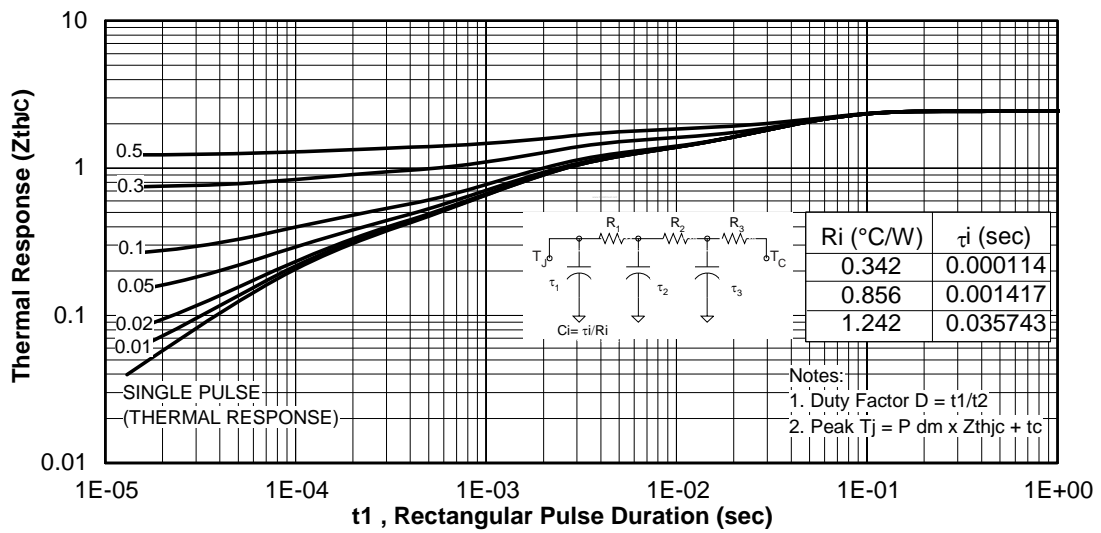
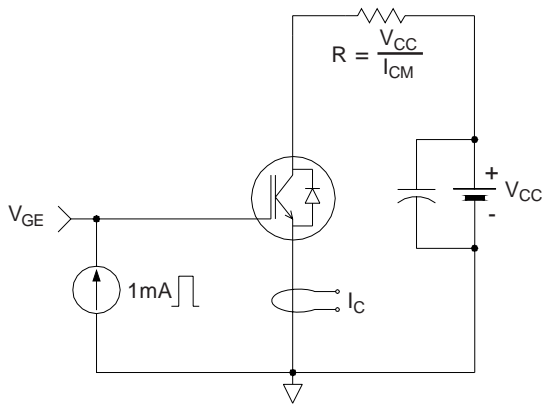
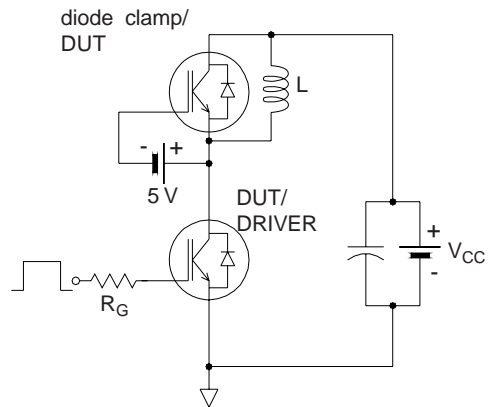


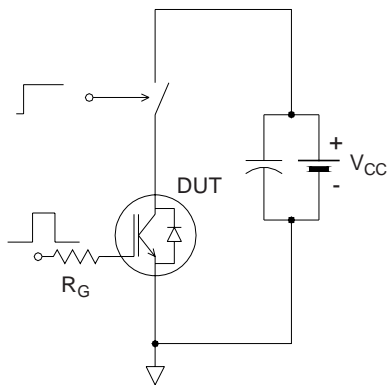
Fig 36. Maximum Transient Thermal Impedance, Junction-to-Case (Brake Diode)



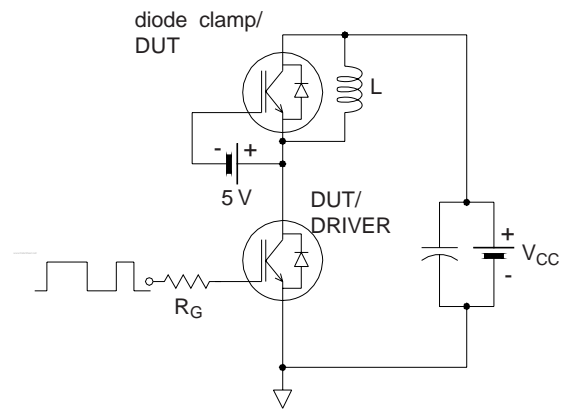
**Fig.C.T.1 - Gate Charge Circuit (turn-off)**



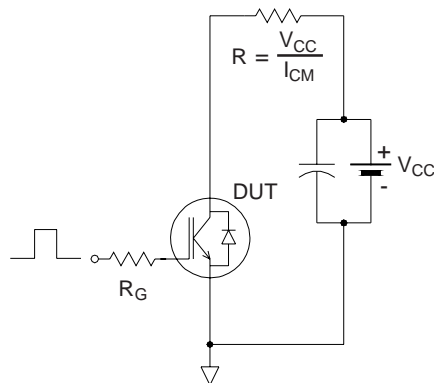
**Fig.C.T.2 - RBSOA Circuit**



**Fig.C.T.3 - S.C. SOA Circuit**



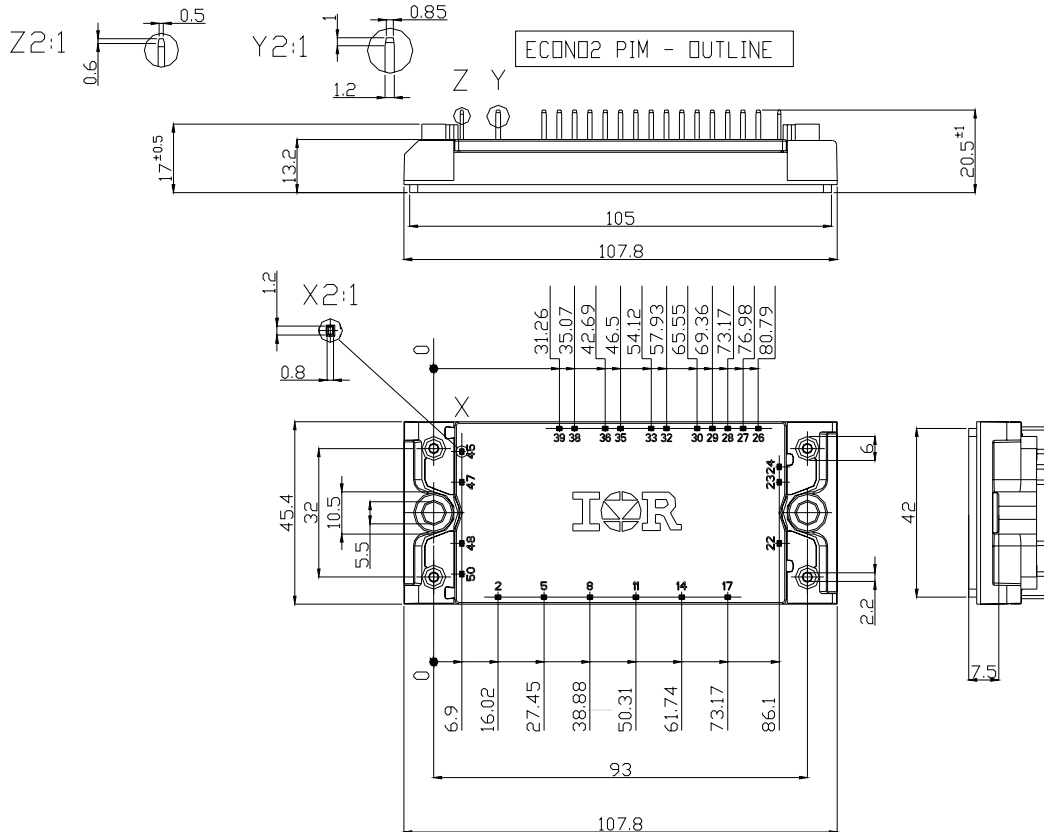
**Fig.C.T.4 - Switching Loss Circuit**



**Fig.C.T.5 - Resistive Load Circuit**

**Econo2 PIM Package Outline**

Dimensions are shown in millimeters (inches)



**Econo2 PIM Part Marking Information**



Data and specifications subject to change without notice.  
 This product has been designed and qualified for Industrial market.  
 Qualification Standards can be found on IR's Web site.

International  
**IOR** Rectifier

IR WORLD HEADQUARTERS: 233 Kansas St., El Segundo, California 90245, USA Tel: (310) 252-7105

TAC Fax: (310) 252-7903

01/07



## Notice

The products described herein were acquired by Vishay Intertechnology, Inc., as part of its acquisition of International Rectifier's Power Control Systems (PCS) business, which closed in April 2007. Specifications of the products displayed herein are pending review by Vishay and are subject to the terms and conditions shown below.

Specifications of the products displayed herein are subject to change without notice. Vishay Intertechnology, Inc., or anyone on its behalf, assumes no responsibility or liability for any errors or inaccuracies.

Information contained herein is intended to provide a product description only. No license, express or implied, by estoppel or otherwise, to any intellectual property rights is granted by this document. Except as provided in Vishay's terms and conditions of sale for such products, Vishay assumes no liability whatsoever, and disclaims any express or implied warranty, relating to sale and/or use of Vishay products including liability or warranties relating to fitness for a particular purpose, merchantability, or infringement of any patent, copyright, or other intellectual property right.

The products shown herein are not designed for use in medical, life-saving, or life-sustaining applications. Customers using or selling these products for use in such applications do so at their own risk and agree to fully indemnify Vishay for any damages resulting from such improper use or sale.

International Rectifier®, IR®, the IR logo, HEXFET®, HEXSense®, HEXDIP®, DOL®, INTERO®, and POWIRTRAIN® are registered trademarks of International Rectifier Corporation in the U.S. and other countries. All other product names noted herein may be trademarks of their respective owners.