

## Battery Protection IC for Single-cell Pack

### Features

- Normal operation: 3uA typ. @ VCC = 3.9V
- Over-charge detection voltage ( $V_{CU}$ )  
4.25~4.3V, accuracy:  $\pm 50\text{mV}$
- Over-charge release voltage ( $V_{CR}$ )  
4.05~4.1V, accuracy:  $\pm 50\text{mV}$
- Over-discharge detection voltage ( $V_{DL}$ )  
2.4V, accuracy:  $\pm 100\text{mV}$
- Over-discharge release voltage ( $V_{DR}$ )  
3.0V, accuracy:  $\pm 100\text{mV}$
- Over-current detection voltage ( $V_{IOV}$ )  
0.15V, accuracy:  $\pm 30\text{mV}$
- Short circuit detection voltage ( $V_{SHORT}$ )  
1.0V
- Reset resistance for over current protection  
> 500K $\Omega$
- Delay time clock is generated with internal circuit

### Applications

- Lithium-ion/Lithium polymer protector of over-charge, over-discharge, excess-current for battery pack
- High precision protector for cell-phones and any other gadgets using on board Lithium-ion/Lithium polymer battery

### Description

The GB5101L series are protection ICs for over-charge/discharge of rechargeable one-cell Lithium-ion/Lithium polymer excess load current, further include a short circuit protector for preventing large external short circuit and excess charge/discharge-current.

### Ordering and Marking Information

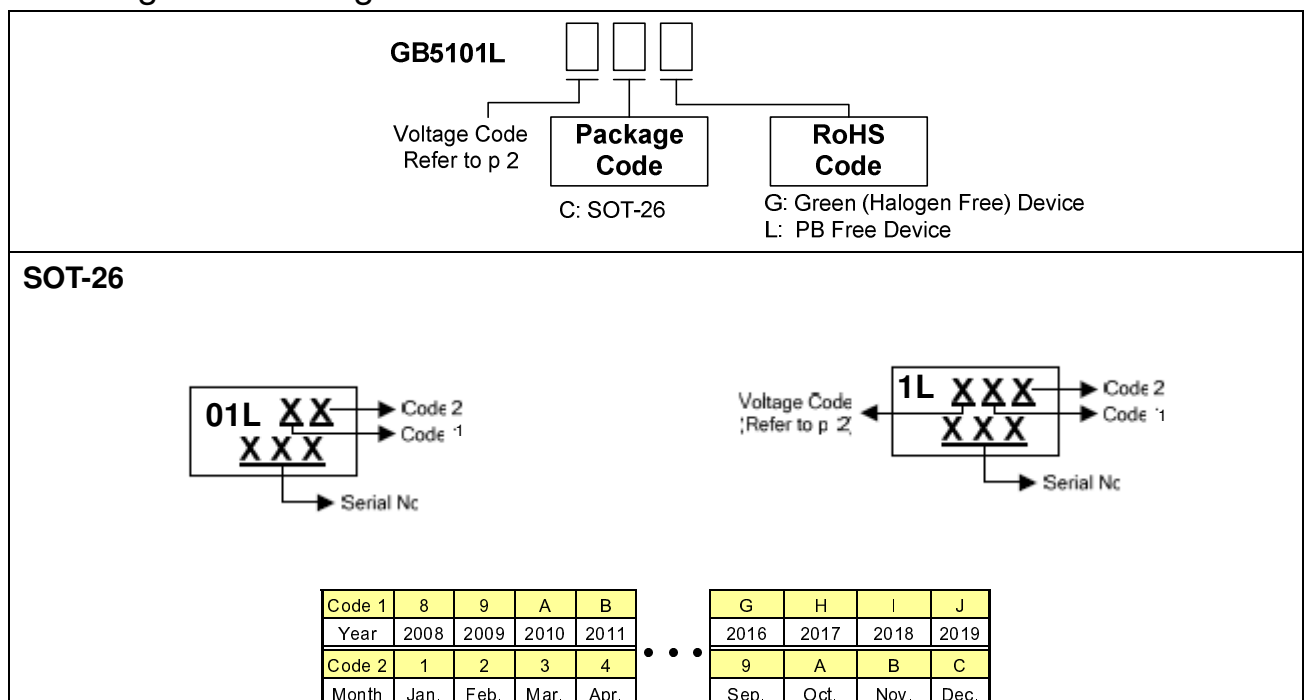

Greenergy OPTO Inc. reserves the right to make changes to improve reliability or manufacture ability without notice, and advise customers to obtain the latest version of relevant information to verify before placing orders.

### Voltage Version

| Package  | Marking      | Over-charge<br>Detection Voltage<br>$V_{CU}$ (V) | Over-charge<br>Release<br>Voltage<br>$V_{CR}$ (V) | Over-discharge<br>Detection<br>Voltage<br>$V_{DL}$ (V) | Over-discharge<br>Release Voltage<br>$V_{DR}$ (V) | Over-current<br>Detection<br>Voltage<br>$V_{IOV}$ (mV) |
|----------|--------------|--|---|--|---|--|
|          | 01LXX<br>XXX | $4.300 \pm 0.05$                                 | $4.100 \pm 0.05$                                  | $2.4 \pm 0.1$  | $3.0 \pm 0.1$                                     | $150 \pm 30$   |
| <b>A</b> | 1LAXX<br>XXX | $4.275 \pm 0.05$                                 | $4.075 \pm 0.05$                                  | $2.4 \pm 0.1$  | $3.0 \pm 0.1$                                     | $150 \pm 30$   |
| <b>B</b> | 1LBXX<br>XXX | $4.250 \pm 0.05$                                 | $4.050 \pm 0.05$                                  | $2.4 \pm 0.1$  | $3.0 \pm 0.1$                                     | $150 \pm 30$   |

### Pin Configuration

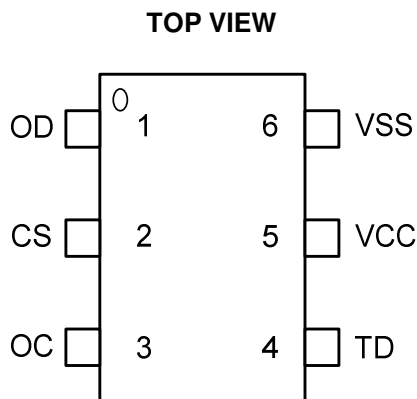

### Pin Description

| Pin No. | Symbol | Description                                     |
|---------|--------|---|
| 1       | OD     | Output of over-discharge detection, CMOS output |
| 2       | CS     | Voltage detection pin between CS and VSS        |
| 3       | OC     | Output of over-charge detection, CMOS output    |
| 4       | TD     | Test pin for delay time measurement             |
| 5       | VCC    | Power supply pin                                |
| 6       | VSS    | Ground pin for the IC                           |

### Absolute Maximum Ratings

Input voltage between VCC and VSS -----  $V_{SS} - 0.3 \sim V_{SS} + 10V$   
 OC output pin voltage -----  $V_{CC} - 28 \sim V_{CC} + 0.3V$   
 OD output pin voltage -----  $V_{SS} - 0.3 \sim V_{CC} + 0.3V$



CS input pin voltage ----- VCC-28~ VCC+0.3V  
Operating temperature range ----- -40 ~ 85 °C  
Storage temperature range ----- -40 ~ 125 °C

### Block Diagram

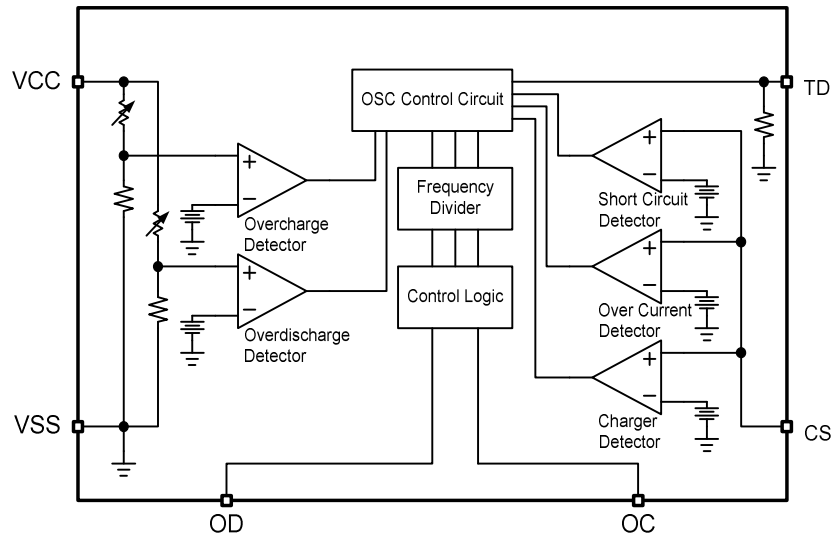

**Electrical Characteristics** ( $T_A = 25^\circ\text{C}$ )

| Parameter                           | Conditions   | Symbol             | Min.                       | Typ.             | Max.                       | Unit          |
|-------------------------------------|--|--------------------|----------------------------|------------------|----------------------------|---------------|
| <b>CURRENT CONSUMPTION</b>          |  |                    |                            |                  |                            |               |
| Supply current                      | VCC = 3.9V   | $I_{\text{OPE}}$   |                            | 3.0              | 6.0                        | $\mu\text{A}$ |
| Over-discharge Supply current       | VCC = 2.0V   | $I_{\text{OD}}$    |                            | 2.0              | 4.0                        | $\mu\text{A}$ |
| <b>DETECTION VOLTAGE</b>            |  |                    |                            |                  |                            |               |
| Over-charge detection voltage       |  | $V_{\text{CU}}$    | $V_{\text{CU}}$<br>-0.050  | $V_{\text{CU}}$  | $V_{\text{CU}}$<br>+0.050  | V             |
| Over-charge release voltage         |  | $V_{\text{CR}}$    | $V_{\text{CR}}$<br>-0.050  | $V_{\text{CR}}$  | $V_{\text{CR}}$<br>+0.050  | V             |
| Over-discharge detection voltage    |  | $V_{\text{DL}}$    | $V_{\text{DL}}$<br>-0.100  | $V_{\text{DL}}$  | $V_{\text{DL}}$<br>+0.100  | V             |
| Over-discharge release voltage      |  | $V_{\text{DR}}$    | $V_{\text{DR}}$<br>-0.100  | $V_{\text{DR}}$  | $V_{\text{DR}}$<br>+0.100  | V             |
| Over-current detection voltage      |  | $V_{\text{IOV}}$   | $V_{\text{IOV}}$<br>-0.030 | $V_{\text{IOV}}$ | $V_{\text{IOV}}$<br>+0.030 | V             |
| Short current detection voltage     |  | $V_{\text{SHORT}}$ | 0.7                        | 1.0              | 1.7                        | V             |
| Charger detection voltage           |  | $V_{\text{CHA}}$   | -0.3                       | -0.1             | -0.05                      | V             |
| <b>DELAY TIME</b>                   |  |                    |                            |                  |                            |               |
| Overcharge detection delay time     |  | $T_{\text{CU}}$    |                            | 80               | 200                        | mS            |
| Over discharge detection delay time |  | $T_{\text{DL}}$    |                            | 40               | 100                        | mS            |
| Over-current detection delay time   |  | $T_{\text{IOV}}$   |                            | 10               | 20                         | mS            |
| Short current detection delay time  |  | $T_{\text{SHORT}}$ |                            | 10               | 50                         | $\mu\text{S}$ |
| <b>OUTPUT THRESHOLD</b>             |  |                    |                            |                  |                            |               |
| OC Output High Voltage              | VCC = 3.5V,<br>$I_o = -5\mu\text{A}$               | $V_{\text{OCH}}$   | 3.0                        | 3.4              |                            | V             |
| OC Output Low Voltage               | VCC = 4.5V,<br>CS = 0V, $I_o$<br>= 5 $\mu\text{A}$ | $V_{\text{OCL}}$   |                            | 0.1              | 0.5                        | V             |
| OD Output High Voltage              | VCC = 3.5V,<br>$I_o = -5\mu\text{A}$               | $V_{\text{ODH}}$   | 3.0                        | 3.4              |                            | V             |
| OD Output Low Voltage               | VCC = 2.0V,<br>$I_o = 5\mu\text{A}$                | $V_{\text{ODL}}$   |                            | 0.1              | 0.5                        | V             |

## Timing Chart

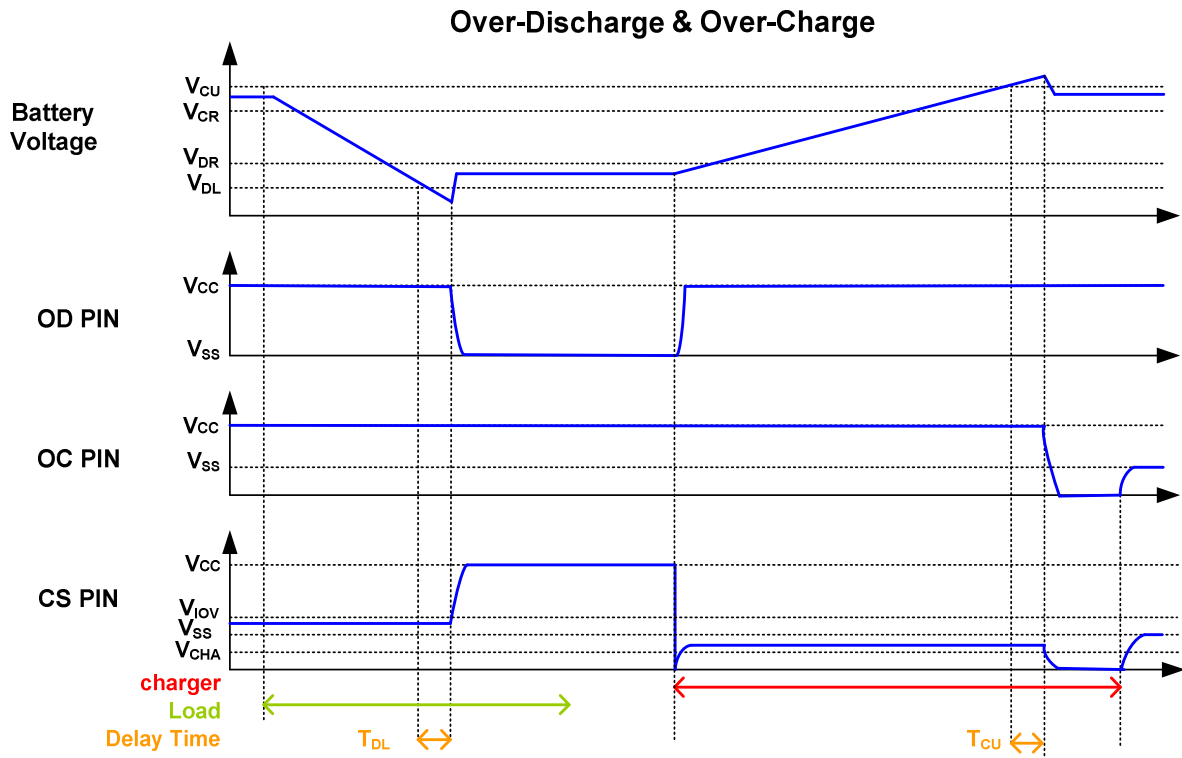

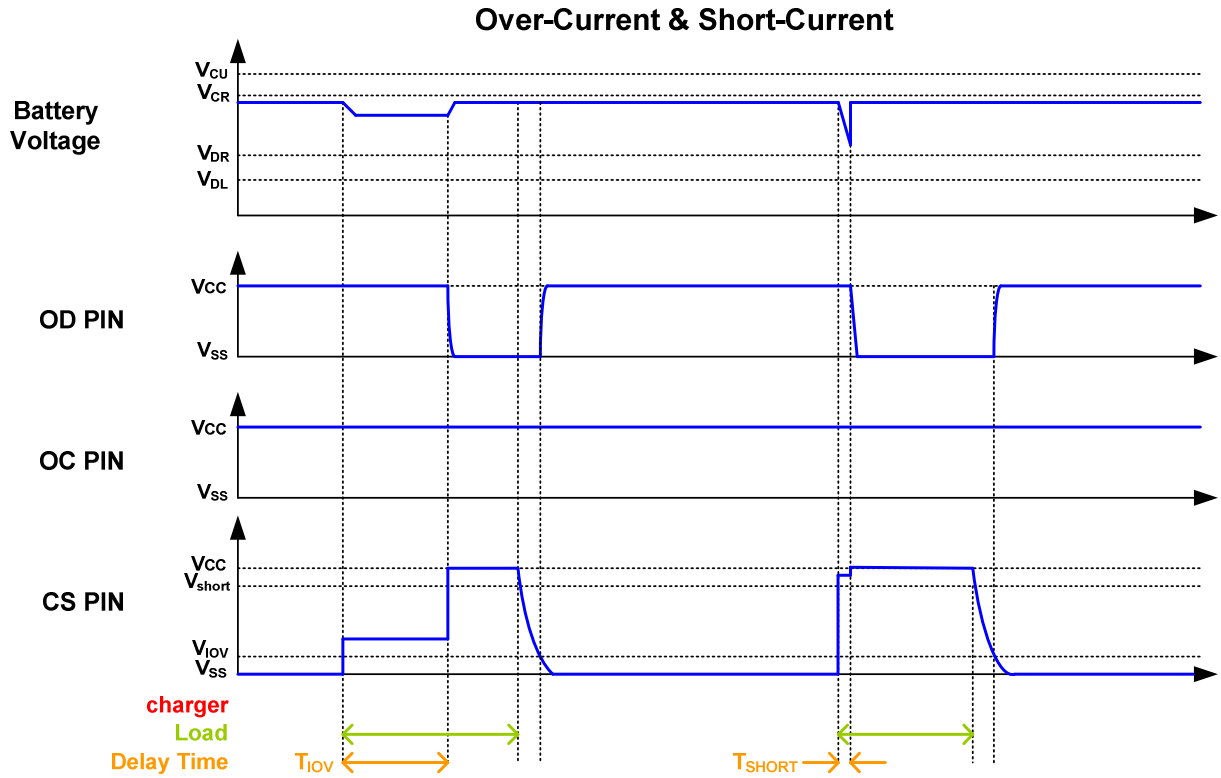

Timing Chart (Cont.)

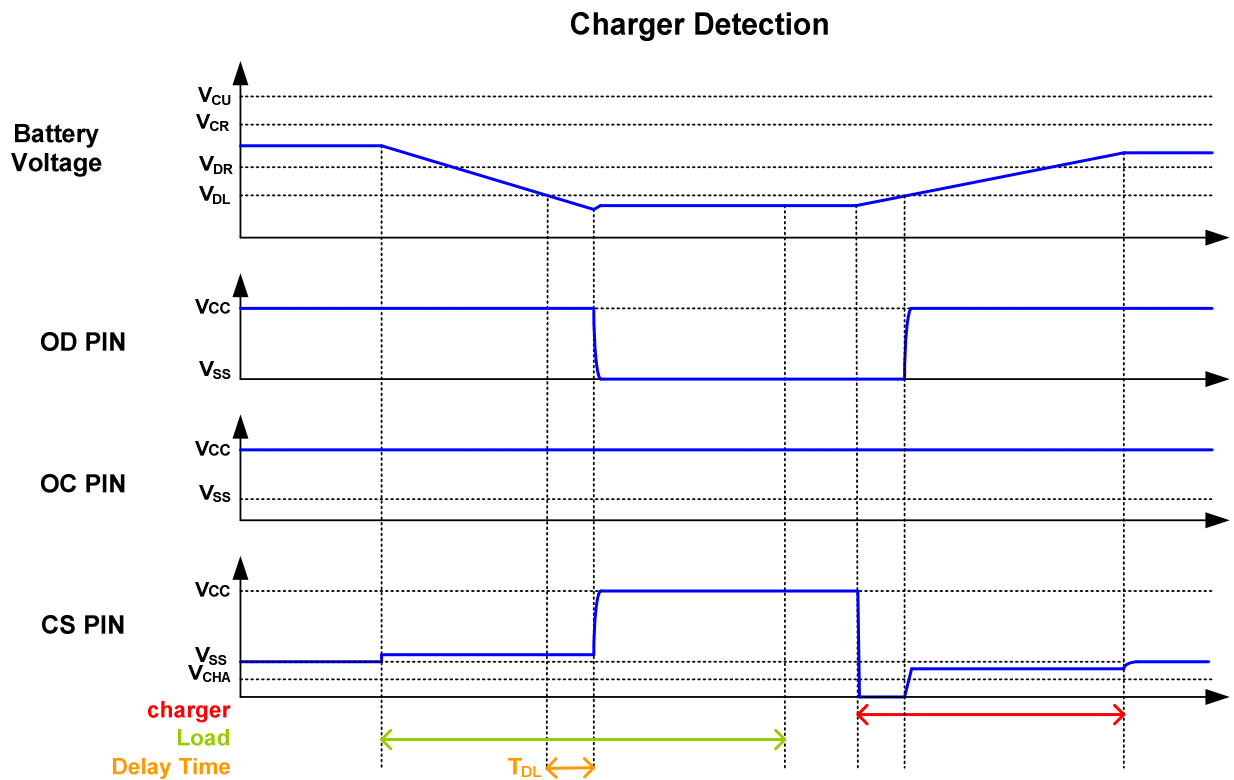

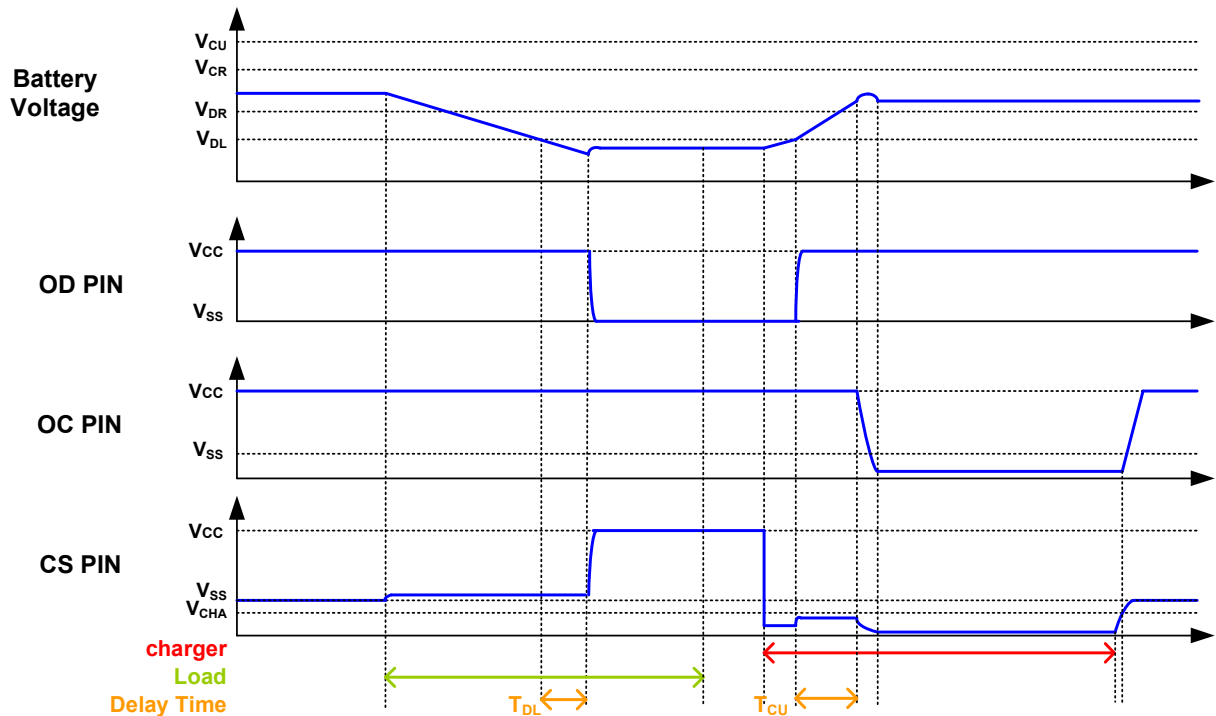
**Abnormal Charge Current Detection**

## Description of Operation

### Normal Status

This IC monitors the voltage of the battery connected between the VCC pin and VSS pin and the voltage difference between the CS pin and VSS pin to control charging and discharging. When the battery voltage is in the range from over-discharge detection voltage ( $V_{DL}$ ) to over-charge detection voltage ( $V_{CU}$ ), the CS pin voltage is no more than the discharge over-current detection voltage ( $V_{IOV}$ ), the IC turns both the charging and discharging control FETs on. This condition is called the normal status. Under this condition, charging and discharging can be carried out freely. The resistance ( $R_{VMD}$ ) between the CS pin and VCC pin, and the resistance ( $R_{VMS}$ ) between the CS pin and VSS pin are not connected in the normal status. Caution when the battery is connected for the first time, discharging pin may not be able to function. Please short the CS pin and VSS pin or connect the

charger to restore the normal status.

### Over-charge Status

When the battery voltage becomes higher than over-charge detection voltage ( $V_{CU}$ ) during charging in the normal status and detection continues for the over-charge detection delay time ( $T_{CU}$ ) or longer, the GB5101L turns the charging control FET off to stop charging. This condition is called the over-charge status. The resistance ( $R_{VMD}$ ) between the CS pin and VCC pin, and the resistance ( $R_{VMS}$ ) between the CS pin and VSS pin are not connected in the over-charge status. The over-charge status is released in the following two cases:

- (1) In the case that the CS pin voltage is higher than or equal to charger detection voltage ( $V_{CHA}$ ), and is lower than the discharge over-current detection voltage ( $V_{IOV}$ ), GB5101L releases the over-charge status when the battery voltage falls below the over-charge release voltage ( $V_{CR}$ ).
- (2) In the case that the CS pin voltage is higher than

or equal to the discharge over-current detection voltage ( $V_{IOV}$ ), GB5101L releases the over-charge status when the battery voltage falls below the over-charge detection voltage ( $V_{CU}$ ). When the discharge is started by connecting a load after the over-charge detection, the CS pin voltage rises higher than the voltage at VSS pin due to the voltage of the parasitic diode. This is because the discharge current flows through the parasitic diode in the charging control FET. If this CS pin voltage is higher than or equal to the discharge over-current detection voltage ( $V_{IOV}$ ), the GB5101L releases the over-charge status when the battery voltage is lower than or equal to the over-charge detection voltage ( $V_{CU}$ ).

#### **Over-discharge Status**

When the battery voltage falls below discharge detection voltage ( $V_{DL}$ ) during discharging in the normal status and the detection continues for the over-discharge detection delay time ( $T_{DL}$ ) or longer, the GB5101L turns the discharging control FET off to stop discharging. This condition is called the over-discharge status. Under the over discharge status, the CS pin voltage is pulled up by the resistor between the CS pin and VCC pin in the IC ( $R_{VMD}$ ). When a battery in the over-discharge status is connected to a charger and provided that the CS pin voltage is lower than charger detection voltage ( $V_{CHA}$ ), the GB5101L releases the over-discharge status and turns the discharging FET on when the battery voltage reaches over-discharge detection voltage ( $V_{DL}$ ) or higher. When a battery in the over-discharge status is connected to a charger and provided that the CS pin voltage is not lower than charger detection voltage ( $V_{CHA}$ ), the GB5101L releases the over-discharge status when the battery voltage reaches over-discharge release voltage ( $V_{DR}$ ) or higher.

#### **Discharge Over-current Status (Discharge Over-current or Short-circuiting)**

When a battery is in the normal status, the voltage of the CS pin is equal to or higher than the discharge over-current detection voltage because the discharge current is higher than the specified value and the status lasts for the discharge over-current detection delay time, the discharge control FET is turned off and discharging is stopped. This status is called the discharge over-current status. In the discharge over-current status, the CS pin and VSS pin are shorted by the resistor between CS pin and VSS pin ( $R_{VMS}$ ) in the IC. However, the voltage of the CS pin is at the VCC potential due to the load as long as the load is connected. When the load is disconnected, the CS pin returns to the VSS potential. This IC detects the status when the impedance between the Bat+ pin and Bat- pin increases and is equal to the impedance that enables automatic restoration and the voltage at the CS pin returns to discharge over-current detection voltage ( $V_{IOV}$ ) or lower, the discharge over-current status is restored to the normal status. Even if the connected impedance is smaller than automatic restoration level, the GB5101L will be restored to the normal status from discharge over-current detection status when the voltage at the CS pin becomes the discharge over-current detection voltage ( $V_{IOV}$ ) or lower by connecting the charger. The resistance ( $R_{VMD}$ ) between the CS pin and VCC pin is not connected in the discharge over-current detection status.

#### **Detection for Abnormal Charging Current**

During charging a battery which is in the normal status, if the CS pin voltage becomes lower than the charger detection voltage ( $V_{CHA}$ ) and this status is held longer than the over-charge detection delay time ( $T_{CU}$ ), the GB5101L turns off the charge-control FET to stop charging. This is detection for abnormal



charging current. This function works in the case that the OD pin voltage is high, and the CS pin voltage becomes lower than the charger detection voltage ( $V_{CHA}$ ). Thus if the abnormal charger current flows in the battery in the over-discharge status, GB5101L turns off the charge-control FET to stop charging; the OD pin voltage goes high that the battery voltage becomes higher than the over-discharge detection voltage, and after the over-charge detection delay time ( $T_{CU}$ ). The status irregular charging current detection is released by the lower potential difference between the CS and VSS pin than the charger detection voltage ( $V_{CHA}$ ).

### Typical Application Circuit

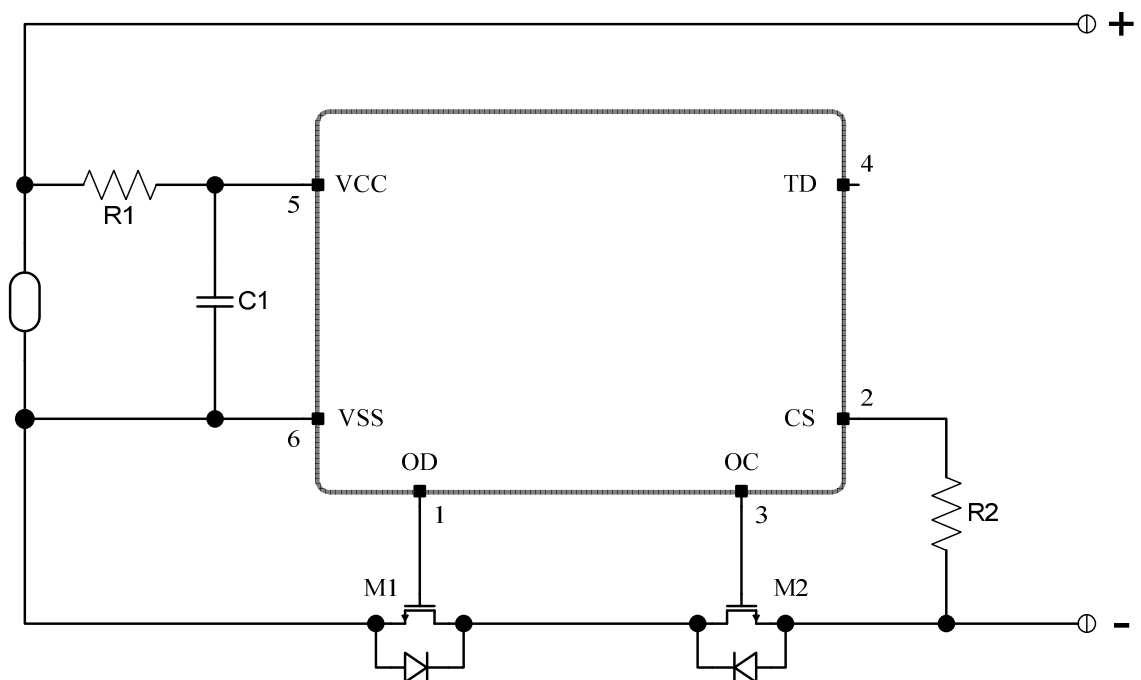

### Constant for External Components

| Symbol | Part             | Purpose  | Min.          | Typ.         | Max.        | Remarks  |
|--------|------------------|--|---------------|--------------|-------------|--|
| M1     | N-channel MOSFET | Discharge control                              | —             | —            | —           | Threshold voltage $\leq$ Over-discharge detection voltage<br>Gate to source withstanding voltage $\geq$ charger voltage    |
| M2     | N-channel MOSFET | Charge control                                 | —             | —            | —           | Threshold voltage $\leq$ Over-discharge detection voltage<br>Gate to source withstanding voltage $\geq$ charger voltage    |
| R1     | Resistor         | ESD protection, for power fluctuation          | 47 $\Omega$   | 100 $\Omega$ | 1K $\Omega$ | Resistance should be as small as possible to avoid lowering of the overcharge detection accuracy caused by VCC pin current |
| C1     | Capacitor        | For power fluctuation                          | 0.022 $\mu$ F | 0.1 $\mu$ F  | 1.0 $\mu$ F | Install a capacitor of 0.022 $\mu$ F or higher between VCC and VSS   |
| R2     | Resistor         | Protection for reverse connection of a charger | 300 $\Omega$  | 1K $\Omega$  | 4K $\Omega$ | Select a resistance as large as possible to prevent large current when a charger is connected in reverse                   |

## Package Information

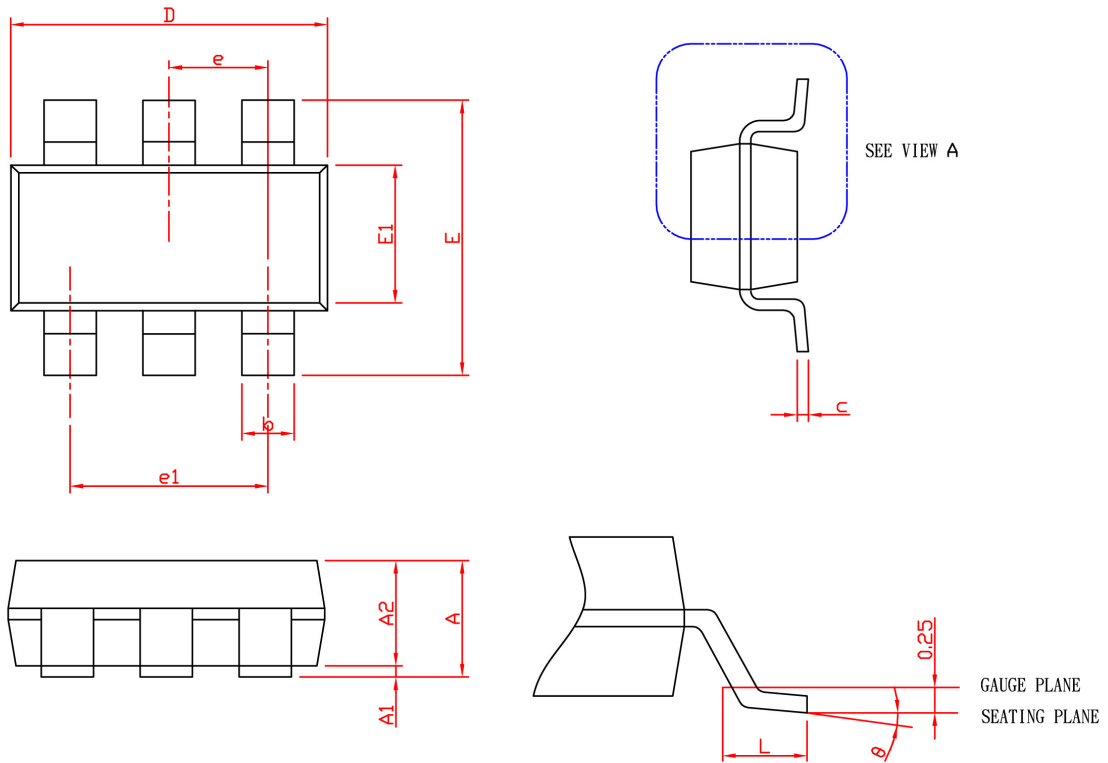

| SYMBOL   | SOT-26      |      |           |       |
|----------|-------------|------|-----------|-------|
|          | MILLIMETERS |      | INCHES    |       |
|          | MIN.        | MAX. | MIN.      | MAX.  |
| A        |             | 1.45 |           | 0.057 |
| A1       | 0.00        | 0.15 | 0.000     | 0.006 |
| A2       | 0.90        | 1.30 | 0.035     | 0.051 |
| b        | 0.30        | 0.50 | 0.012     | 0.020 |
| c        | 0.08        | 0.22 | 0.003     | 0.009 |
| D        | 2.70        | 3.10 | 0.106     | 0.122 |
| E        | 2.60        | 3.00 | 0.102     | 0.118 |
| E1       | 1.40        | 1.80 | 0.055     | 0.071 |
| e        | 0.95 BSC    |      | 0.037 BSC |       |
| e1       | 1.90 BSC    |      | 0.075 BSC |       |
| L        | 0.30        | 0.60 | 0.012     | 0.024 |
| $\theta$ | 0°          | 8°   | 0°        | 8°    |

Note : 1. Followed from JEDEC TO-178 AB.

2. Dimension D and E1 do not include mold flash, protrusions or gate burrs. Mold flash, protrusions or gate burrs shall not exceed 10 mil per side.

## Carrier Tape & Reel Dimensions

### SOT-26

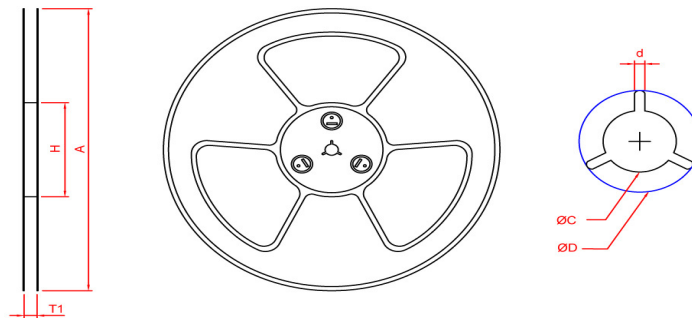
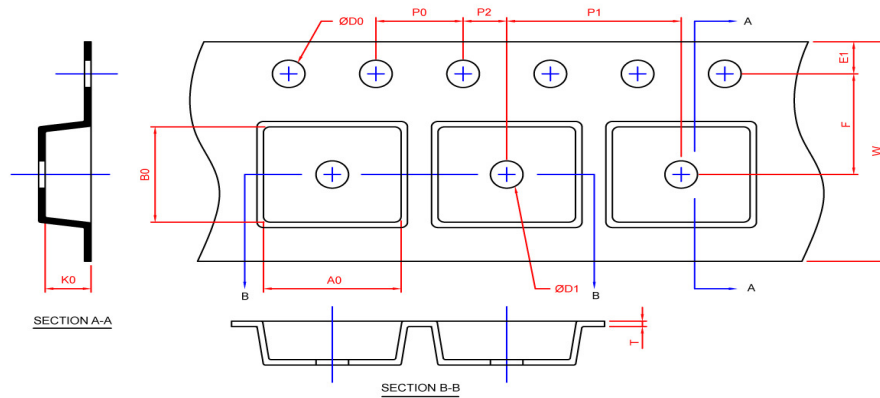

| Application | A                | H              | T1                      | C                        | d        | D                       | W               | E1              | F               |
|-------------|------------------|----------------|-------------------------|--------------------------|----------|-------------------------|-----------------|-----------------|-----------------|
| SOT-26      | $178.0 \pm 2.00$ | 50 MIN.        | $8.4 + 2.00$<br>$-0.00$ | $13.0 + 0.50$<br>$-0.20$ | 1.5 MIN. | 20.2 MIN.               | $8.0 \pm 0.30$  | $1.75 \pm 0.10$ | $3.5 \pm 0.05$  |
|             | P0               | P1             | P2                      | D0                       | D1       | T                       | A0              | B0              | K0              |
|             | $4.0 \pm 0.10$   | $4.0 \pm 0.10$ | $2.0 \pm 0.05$          | $1.5 + 0.10$<br>$-0.00$  | 1.0 MIN. | $0.6 + 0.00$<br>$-0.40$ | $3.20 \pm 0.20$ | $3.10 \pm 0.20$ | $1.50 \pm 0.20$ |

(mm)

| Application | Carrier Width | Cover Tape Width | Devices Per Reel |
|-------------|---------------|------------------|------------------|
| SOT -26     | 8             | 5.3              | 3000             |

## Tape and Reel Specification

SOT-26

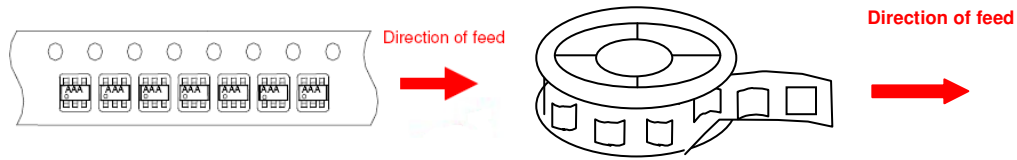

Greenergy OPTO, Inc. reserves the right to make corrections, modifications, enhancements, improvements, and other changes to its products and services at any time and to discontinue any product or service without notice. Customers should obtain the latest relevant information before placing orders and should verify that such information is current and complete.