

GBPC6005 - GBPC610

GLASS PASSIVATED SINGLE-PHASE BRIDGE RECTIFIERS

PRV : 50 - 1000 Volts

Io : 6.0 Amperes

FEATURES :

- * Glass passivated chip
- * High surge current capability
- * High current capability
- * High reliability
- * Low reverse current
- * Low forward voltage drop
- * Ideal for printed circuit board
- * **Pb / RoHS Free**

MECHANICAL DATA :

- * Case : Reliable low cost construction utilizing molded plastic technique
- * Epoxy : UL94V-O rate flame retardant
- * Lead : Axial lead solderable per MIL - STD 202 , Method 208 guaranteed
- * Polarity : Polarity symbols marked on case
- * Mounting position : Any
- * Weight : 3.6 grams

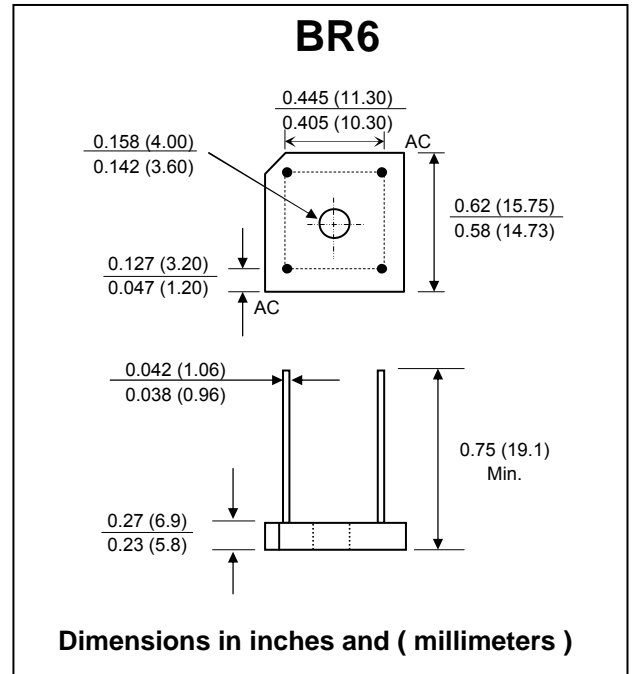

MAXIMUM RATINGS AND ELECTRICAL CHARACTERISTICS

Rating at 25 °C ambient temperature unless otherwise noted.

RATING	SYMBOL	GBPC 6005	GBPC 601	GBPC 602	GBPC 604	GBPC 606	GBPC 608	GBPC 610	UNIT
Maximum Repetitive Peak Reverse Voltage	V_{RRM}	50	100	200	400	600	800	1000	V
Maximum RMS Bridge Input Voltage	V_{RMS}	35	70	140	280	420	560	700	V
Maximum DC Blocking Voltage	V_{DC}	50	100	200	400	600	800	1000	V
Maximum Average Forward Current $T_c = 50\text{ }^\circ\text{C}$ ^(1,2)	$I_{F(AV)}$				6.0				A
Peak Forward Surge Current Single Sine Wave Superimposed on Rated Load	I_{FSM}				175				A
Rating for fusing ($t < 8.3$ ms)	I^2t				127				A ² sec
Maximum Instantaneous Forward Voltage Drop Per Leg at $I_F = 3$ A.	V_F				1.0				V
Maximum DC Reverse Current at $T_a = 25\text{ }^\circ\text{C}$	I_R				5				μA
Rated DC Blocking Voltage Per Leg $T_a = 125\text{ }^\circ\text{C}$	$I_{R(H)}$				500				μA
Typical Junction Capacitance Per Leg(at 4 V, 1MHz)	C_J	186			90				pF
Typical Thermal Resistance Per Leg ⁽¹⁾	$R_{\theta JA}$				22				$^\circ\text{C/W}$
	$R_{\theta JC}$				7.3				$^\circ\text{C/W}$
Operating Junction and Storage Temperature Range	T_J, T_{STG}				- 55 to + 150				$^\circ\text{C}$

Notes :

- (1) Bolt down on heat-sink with silicone thermal compound between bridge and mounting surface for maximum heat transfer with #6 screw
- (2) Unit mounted on 5.5 x 6.0 x 0.11" thick (14 x 15 x 0.3 cm) Al. Plate

RATING AND CHARACTERISTIC CURVES (GBPC6005 - GBPC610)

FIG.1 - DERATING CURVE OUTPUT RECTIFIED CURRENT

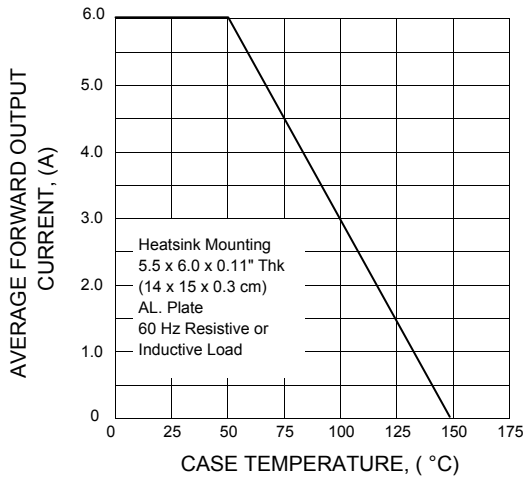

FIG.2 - MAXIMUM NON-REPETITIVE PEAK FORWARD SURGE CURRENT PER LEG

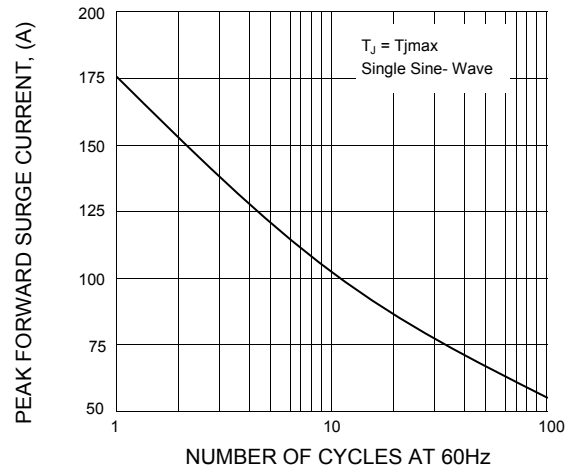

FIG.3 - TYPICAL FORWARD CHARACTERISTICS PER LEG

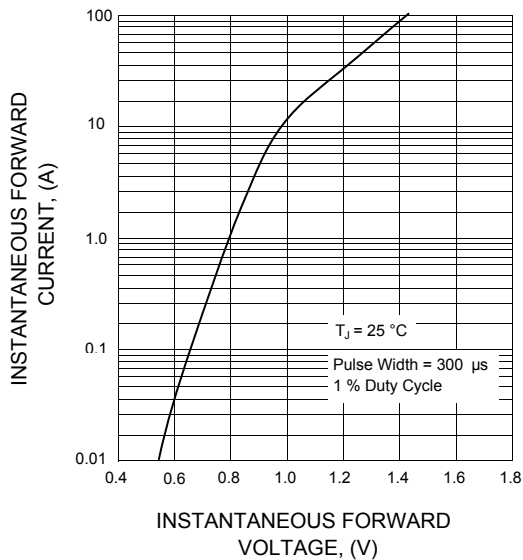

FIG.4 - TYPICAL REVERSE CHARACTERISTICS PER LEG

