

Three-Phase Sine-wave Sensor-Less Fan Motor Driver

Chip description:

The GC5958 provides all the circuitry for sensor-less speed control of three-phase brushless DC motor. The Sine-wave Driver Method will be better low-noise. The controller functions include start-up circuit, back-EMF commutation control, Pulse Width Modulation (PWM) speed control, lock protection, and thermal shutdown circuit. The GC5958 is suitable for both game machine and CPU cooler that need silent drivers. It is available in DFN3x3-10 package.

Chip features:

- PWM Quasi-Sinusoidal Driver
- Three-Phase Sensor-Less Drive Method
- Adjustable Forced Commutation Frequency (for Start-up)
- Built-In External PWM Speed Control
- Built-In Quick Start Function
- FG (Rotation Speed Detection) Output
- Soft Switching Circuit (for Noise Reducing)
- Power Saving Function (PWM Duty Input is 0%)
- Built-In Lock Protection and Auto Restart Function
- Thermal Shutdown Circuit

Chip application:

- Silent Fan Motors

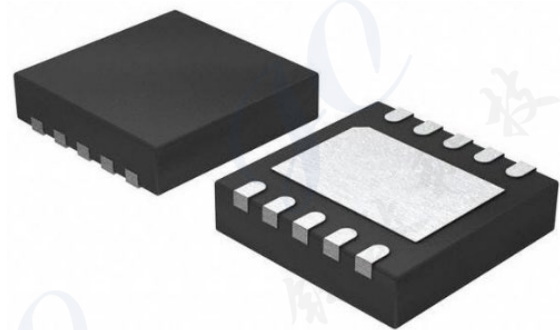

Product name	Package Type	Detail description
GC5958	DFN3x3-10	3.0*3.0, e=0.5

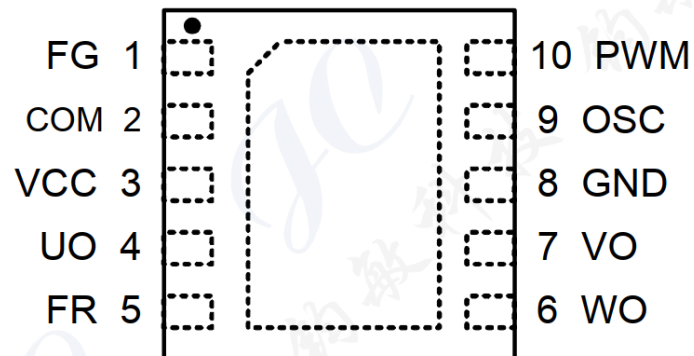
Pin Map:

Pin Description:

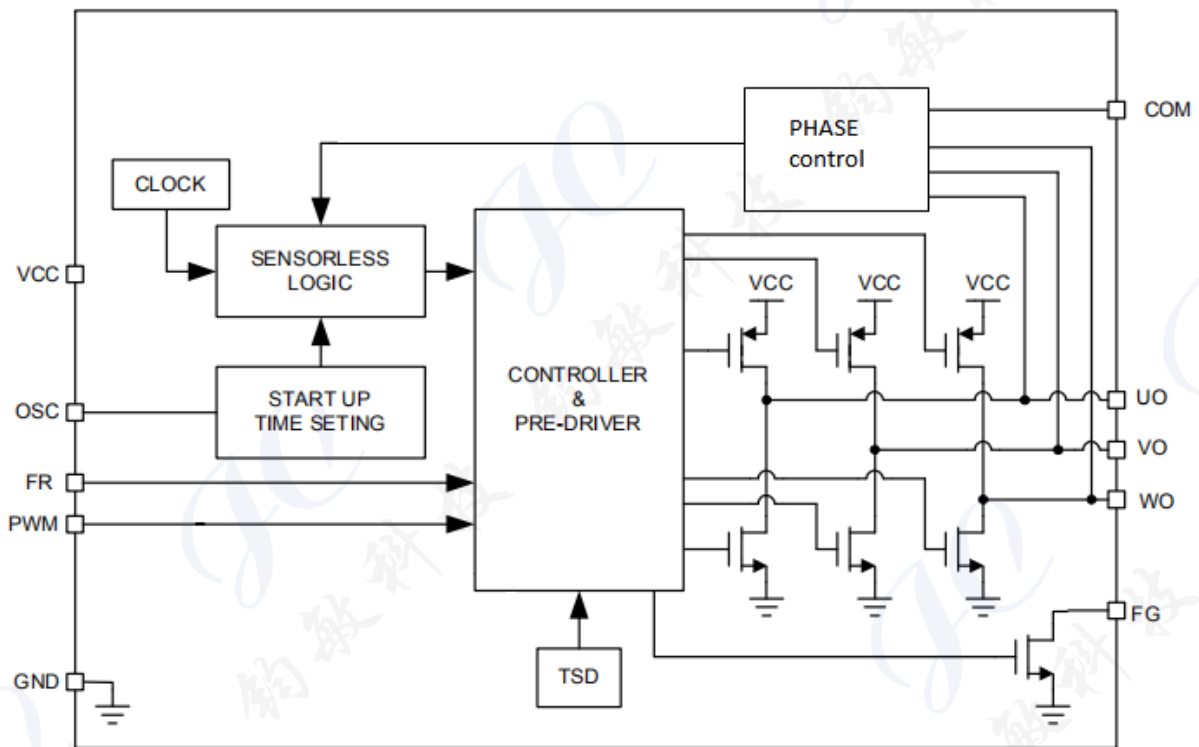
Pin No.	Pin Name	I/O	Pin Function
1	FG	O	Rotation Speed Output. This is an open-drain output.
2	COM	I	Motor Neutral Point Input Pin
3	VCC	power	Supply Pin.
4	UO	O	Driver Output Pin. Output signal for driving motor phase U.
5	FR	I	Motor Spin Direction Control Pin. High Level : U → V → W (Floating) Low Level : U → W → V
6	WO	O	Driver Output Pin. Output signal for driving motor phase W.
7	VO	O	Driver Output Pin. Output signal for driving motor phase V.
8	GND	ground	Ground Pin.
9	OSC	I/O	Start-up Commutation Time Setting. Connect a capacitor to GND to set start-up commutation time.
10	PWM	I	PWM Signal Input Pin. Input PWM signal to control rotation speed.

Block Diagram :

Absolute Maximum Ratings:

(over operating free-air temperature range (unless otherwise noted))

Symbol	Parameter	Rating	Unit
VCC	Power supply	-0.3~7	V
IOUT	UO/VO/WO Pin Output Current	0 to 1	A
V(UO/VO/WO)	UO/VO/WO Pin Output Voltage	-0.3 to 7	V
VFG	FG Pin Output Voltage	-0.3 to 7	V
IFG	FG Pin Sink Current	0 to 10	mA
VFR	FR Pin Input Voltage	-0.3 to 7	V
Top	Operating Temperature	-40~125	°C
Tjmax	Junction Temperature	-40~150	°C
Tstg	Storage Temperature	-60~150	°C
ESD	ESD (HBM)	± 3000	V

Recommended Operating Conditions

Symbol	Parameter	Range	Unit
VCC	VCC Pin Supply Voltage Range	1.8 to 6	V
VPWM	PWM Pin Input Voltage Range	0 to VCC	V
TA	Ambient Temperature	-40 to 120	°C
IOUT	UO/VO/WO Pin Average Output Current	0 to 400	mA

Electrical Characteristics:

(VCC=5V, TA=25°C, unless otherwise specified)

Symbol	Parameter	Test Conditions	Min.	Typ.	Max.	Unit
SUPPLY CURRENT						
ICC1	Operating Current	Rotation Mode, FR=VCC	-	2.9	4	mA
ICC2	Standby Supply Current	PWM=0	-	130	180	uA
PWM CONTROL						
VPWMH	PWM Input High Level Voltage	2.5	-	VCC+0.3		V
VPWML	PWM Input Low Level Voltage	-0.3	-	0.8		V
IPWMH	PWM High Input Current	PWM=VCC	-	0	-	uA
IPWML	PWM Low Input Current	PWM=GND	-	2.6	3	uA
FPWM	PWM Input Frequency	2	-	80		kHz
Oscillator						
VOSCH	OSC Pin High Level Voltage		1	1.2	1.4	V
VOSCL	OSC Pin Low Level Voltage		0.5	0.6	0.7	V
IOSC1	OSC Pin Charge Current	VOSC=0V	-	16.5	-	μA
IOSC2	OSC Pin Discharge Current	VOSC=1.2V	-	16.5	-	μA
OUTPUT DRIVERS						
VO	Output Driver Saturation Voltage	IOUT=250mA, Upper and Lower total	-	0.3	0.44	V
VFG	FG Pin Low Voltage	IFG=5mA	-	0.2	0.3	V
IFGL	FG Pin Leak Current	VFG=7V	-	-	10	uA
VFRH	FR Input High Threshold Voltage		0.5 x VCC	-	VCC	V
VFRL	FR Input Low Threshold Voltage		0	-	0.1 x VCC	V
LOCK PROTECTION						
TON	Lock Detection On Time		1.1	1.3	1.5	sec
TOFF	Lock Detection Off Time		6.2	6.6	7.5	sec

THERMAL SHUTDOWN						
OTS	Over Temperature Shutdown		-	165		°C
	Over Temperature Shutdown Hysteresis		-	30		
QUICK START						
TQS	Quick Start Enable Time		-	16	-	ms

Function Description:

PWM Speed Control (fixed-frequency output)

It is possible to change rotation speed of the motor by switching output transistor. The on-duty of switching depends on the signal from input to PWM terminal. The output PWM frequency is fixed to 30KHz typically.

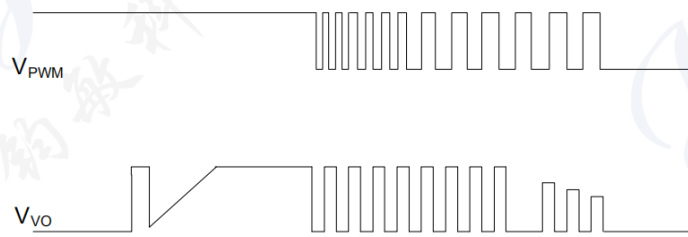

PWM Input Waveform

Quick Start

This IC disables the lock protection function when the PWM input keeps low level for more than 16ms.

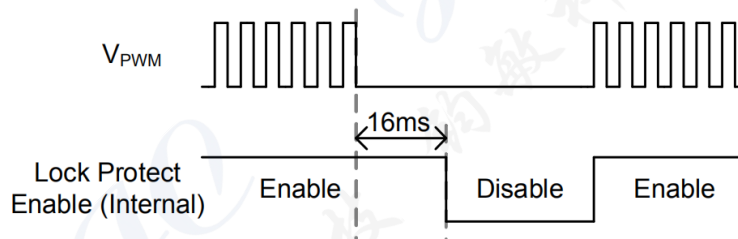

Quick Start Waveform

FGOutput

The FG pin is an open-drain output, connecting a pull up resistor to a high level voltage for the speed detection function. The FG output signal is asynchronous with driver output for stable output frequency.

Soft Switch (sine-wave output)

The is a soft switch function to make phase current be come smooth, which can reduce the noise of motor in switching interval. Using PWM duty cycle control to create the sinusoidal current waveform. BEMF detection window is opened on phase W in order to measure the rotor position so as to define the modulation timing. close to the ideal sine wave output.

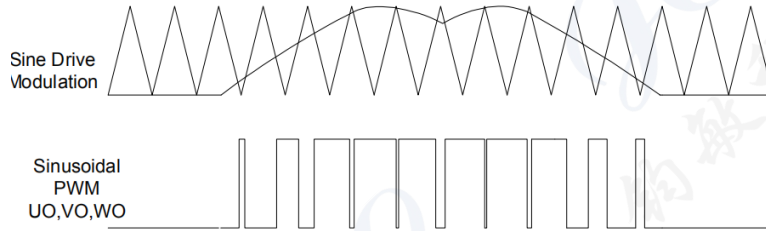

Sinusoidal PWM

Lock Protection and Automatic Restart

The GC5958 provides the lock protection and automatic restart functions to prevent the coil burnout while the fan is locked. As the fan is locked, the IC will come into start up operation for 1 second. Then, the IC will switch to lock protection mode to turn off output driver for 5 seconds. After lock protection mode, the IC switches to start-up operation again. If the locked condition still remains, the lock-and-restart process will be recurred until the locked condition is released.

OSC Capacitor

The capacitor connects from OSC pin to GND can be determined the frequency of force commutation. The optimal design of the frequency could make sure the motor start-up in succeed. Its capacitance from 1000pF to 3300pF is recommended.

Typical Application

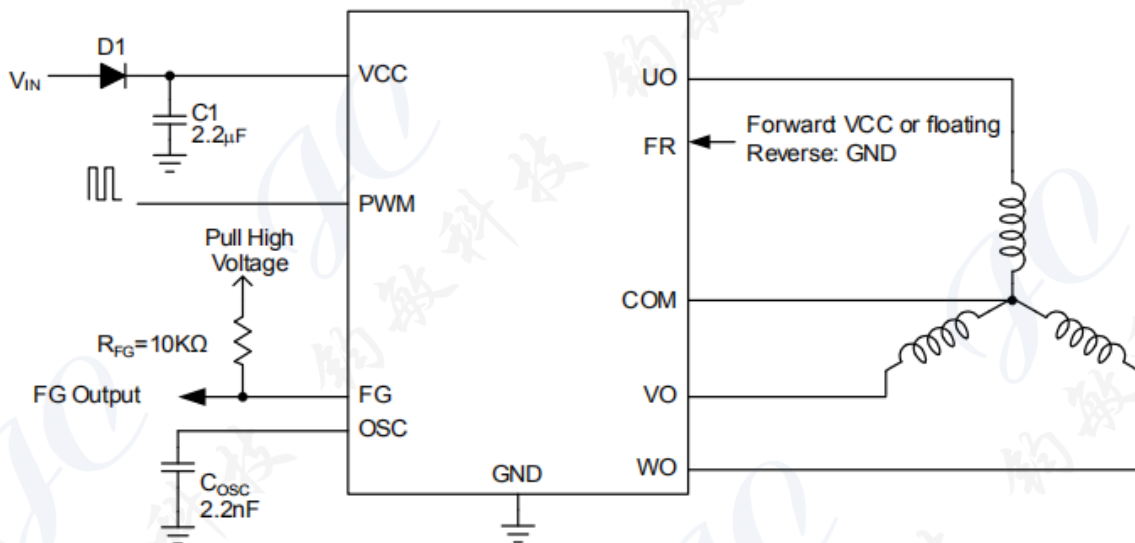

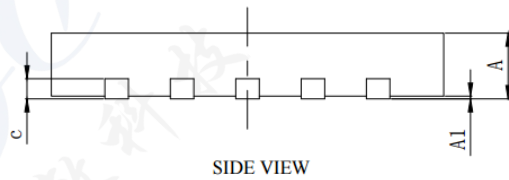
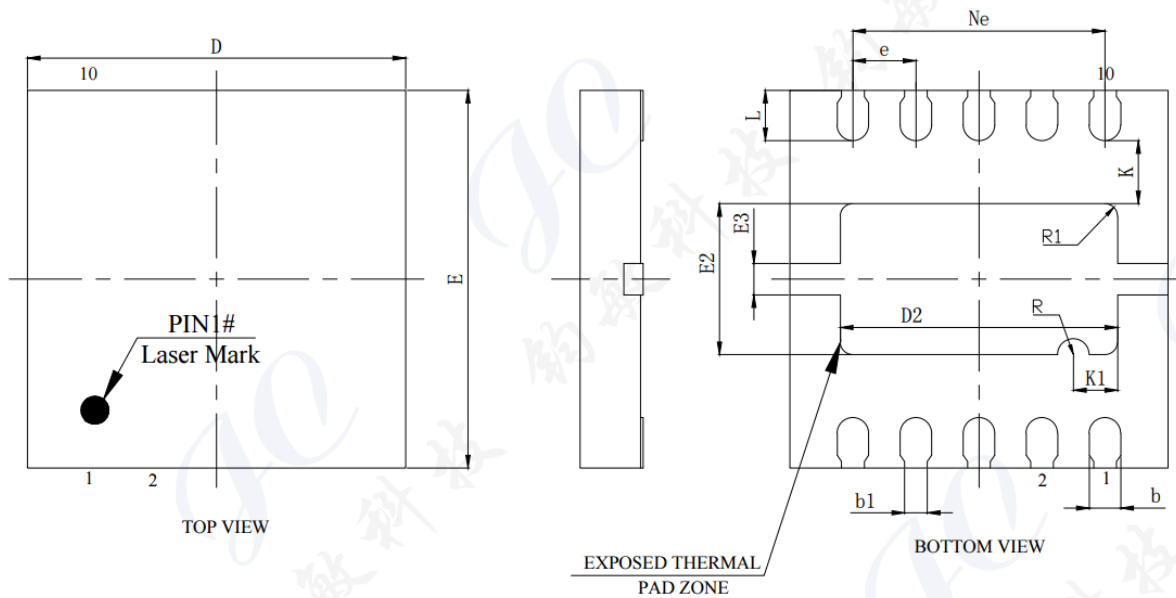
Package Information

SYMBOL	MILLIMETER		
	MIN	NOM	MAX
A	0.45	0.50	0.55
A1	0	0.02	0.05
b	0.20	0.25	0.30
b1	0.18REF		
c	0.150REF		
D	2.95	3.00	3.05
D2	2.10	2.20	2.30
e	0.50BSC		
Ne	2.00BSC		
E	2.95	3.00	3.05
E2	1.10	1.20	1.30
E3	0.20	0.25	0.30
L	0.30	0.40	0.50
R	0.125REF		
R1	0.100REF		
K	0.45	0.50	0.55
K1	0.35REF		