



Gemini Tech CO., LTD.

The LCD(M) Specialist

CONTACT ADDRESS : RM,1521 Investel, 1123-2 Sanbon-dong,
 Gunpo-city, Kyeongki-do, 435-040 Korea
 Tel: 0082-31-455-3200
 Fax: 0082-31-343-2102
 E-mail: sales@findlcd.com



PART NO. : GCB1602E V1.1
 -SFYLYHC06

FOR MESSRS. : _____

CONTENTS

NO.	ITEM	PAGE
1.	COVER	1
2.	RECORD OF REVISION	2
3.	GENERAL SPECIFICATION	3
4.	MECHANICAL DATA	3
5.	ABSOLUTE MAXIMUM RATINGS	4
6.	ELECTRICAL CHARACTERISTICS	5
7.	OPTICAL CHARACTERISTICS	5
8.	OUTLINE DIMENSION	6~7
9.	BLOCK DIAGRAM	7
10	INTERFACE TIMING CHART	8~9
11	INSTRUCTION CODE	10~11
12	CHARACTER GENERATOR ROM	12
13	SPECIFICATION OF QUALITY ASSURANCE	13~17

ACCEPTED BY:

PROPOSED BY:

RECORD OF REVISION

DATE	PAGE	SUMMARY
2011-6-9	---	NEW SPEC
2014-4-21		RF resistor from 91K to 75K

3. General specifications

3.1 General specifications

PLEASE REFER TO:

“CUSTOMER ACCEPTANCE STANDARD SPECIFICATIONS (MS-10-10000)”.

3.2 Quality Assurance and Warranty

PLEASE REFER TO:

“QUALITY ASSURANCE MANUL (MS-10-10001)”.

3.3 This individual specification is prior to general specifications

4. Mechanical data

- Display format: 16 characters x 2 lines
- Microprocessor interface: 8 bits Parallel
- LCD type: STN Positive Yellow-Green
- Backlight color: Yellow-Green
- Viewing angle: 6 o'clock
- LCD controller: SPLC780 or Equivalent
- Module size: 85x 29.5 x 11.4 mm
- View area: 64 x16 mm
- Dot size: 0.56x 0.66 mm
- Character size: 2.96 x 5.56mm
- Driving method: 1/16 duty, 1/5 bias

5. Absolute maximum ratings

5.1 Electrical absolute maximum ratings

<i>I T E M</i>	<i>SYMBOL</i>	<i>MIN.</i>	<i>MAX.</i>	<i>UNIT</i>	<i>COMMENT</i>
POWER SUPPLY FOR LOGIC	V _{DD} -V _{SS}	-0.3	6	V	-----
INPUT VOLTAGE	V _I	V _{SS}	V _{DD}	V	-----
STATIC ELECTRICITY	-----	-----	-----	V	
POWER SUPPLY FOR BACKLIGHT	V _S	-----	-----	V _{rms}	-----
	f _{FL}	-----	-----	KHz	-----
STARTING VOLTAGE FOR BACKLIGHT	-----	-----	-----	V _{rms}	Ta = 25°C
	-----	-----	-----	V _{rms}	Ta = 25°C
POWER SUPPLY FOR LCD	V _{DD} -V ₀	-----	5.0	V	-----

5.2 Environmental absolute maximum ratings

<i>I T E M</i>	<i>OPERATING</i>		<i>STORAGE</i>		<i>COMMENT</i>
	<i>MIN.</i>	<i>MAX.</i>	<i>MIN.</i>	<i>MAX.</i>	
AMBIENT TEMPERATURE	-20°C	70°C	-30°C	80°C	-----
HUMIDITY	NOTE (2)		NOTE (2)		NO CONDENSATION
VIBRATION NOTE (3)	-----	0.5G	-----	2G	10~300Hz XYZ DIRECTIONS 1 Hr EACH
SHOCK NOTE (3)	-----	3G	-----	5G	10 msec XYZ DIRECTIONS 1 TIME EACH
CORROSIVE GAS	NOT ACCEPTABLE		NOT ACCEPTABLE		-----

NOTE (2): Ta ≦ 70°C : 75% RH MAX.

Ta > 70°C : ABSOLUTE HUMIDITY MUST BE LOWER THAN THE HUMIDITY OF
75% RH AT 70°C.

NOTE (3) : 1G = 9.8 m/s²

6. Electrical characteristics

Ta = 25°C VDD = 5.0 V

ITEM	SYMBOL	CONDITION	MIN.	TYP.	MAX.	UNIT
Power supply voltage for circuit	V _{DD} -V _{SS}	-----	4.75	5.0	5.25	V
Power supply voltage for LCD drive	V _{DD} -V ₀	-----	-----	5.0	-----	V
LCD display duty ratio	DUTY	-----	-----	1/16	-----	-----
LED BACKLIGHT	I _{fp}	I mse0 plus 10% Dutg cyele		-----		mA
		Operating voltage	-----	4.1	-----	V
		Forward current		100	-----	mA
LED Lifetime	-----	V _{FL} =3.0Vrms f _{FL} = KHZ	-----	-----	-----	Hr
Power supply LCD current	I _{EE}	V _{DD} -V ₀ = 4.7 V	-----	----	-----	mA

LED backlight: Due to the LED backlight working current is XXX Max, and LED chips Vop may be different, Gemini will adjust the backlight resistor according to the LED chips Vop, to meet the brightness maximum.

7. Optical characteristics

Ta = 25°C V_{DD}-V₀ = 4.7V

ITEM	SYMBOL	CONDITION	MIN.	TYP.	MAX.	UNIT	NOTE
Viewing angle	Φ2-Φ1	K ≧ 2.0	-35	-----	20	deg.	1
Contrast ratio	K	Φ = 10° θ = 0°	4.0	-----	-----	-----	1
Response time (at 25°C)	tr (rise)	Φ = 10° θ = 0°	-----	-----	250	ms	1
	tf (fall)	Φ = 10° θ = 0°	-----	-----	250	ms	1
The brightness of backlighting source	B	V _{FL} =3.0Vrms f _{FL} = KHZ	---	375	---	cd/m ²	2

NOTE (1): SEE CUSTOMER ACCEPTANCE STANDARD SPECIFICATION FOR DEFINITION OF OPTICAL CHARACTERISTICS

NOTE (2): UNDER NORMAL TEMPERATURE AND HUMIDITY IN A DARK ROOM

8. Outline dimension

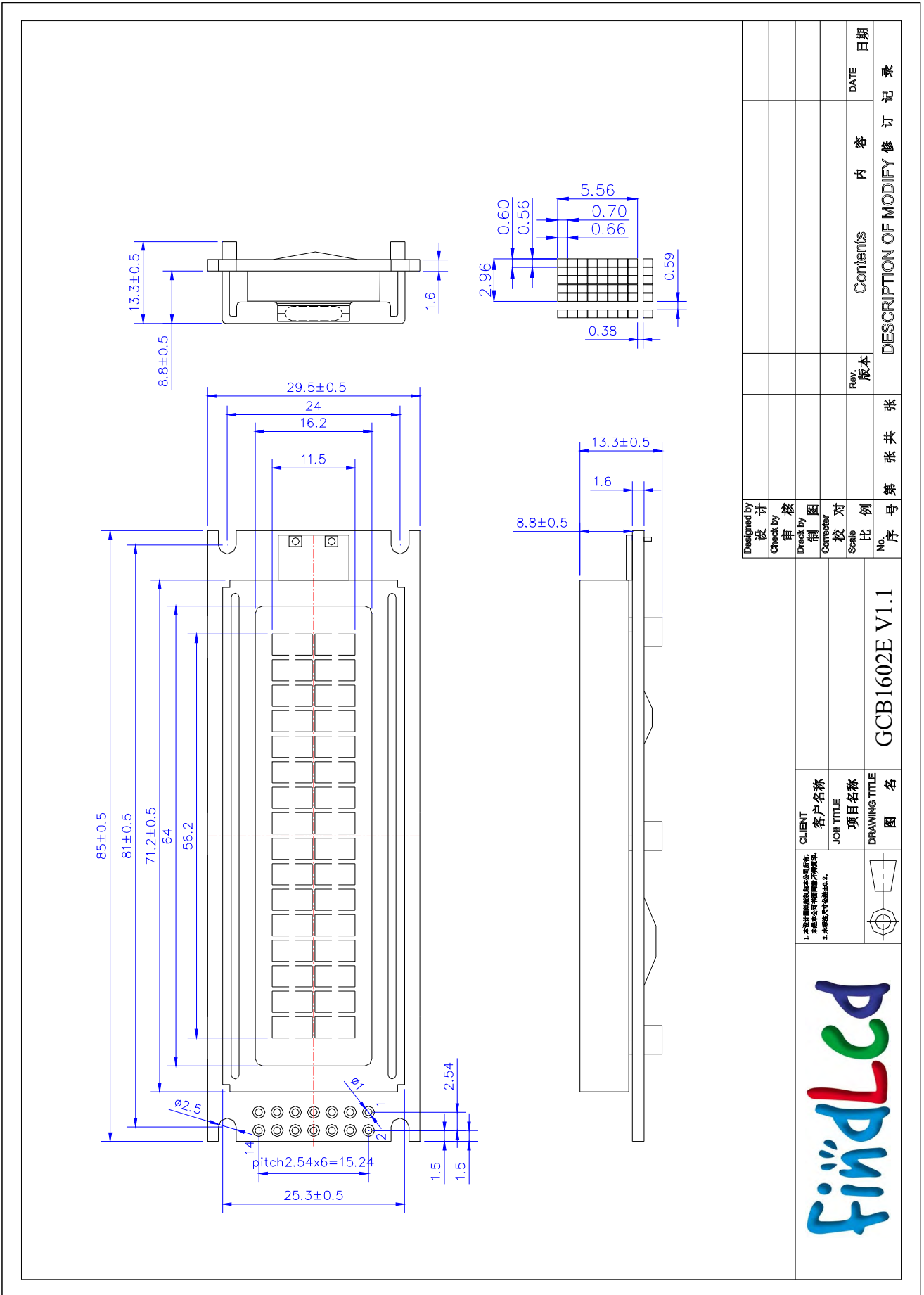

Designed by 设计					
Check by 审核					
Draw by 制图					
Controler 校对					
Scale 比例					
No. 序号					
张 张					
共 共					
张 张					
第 第					
号 号					
Rev. 版本					
Contents 内容					
DESCRIPTION OF MODIFY 修改记录					
DATE 日期					

CLIENT
客户名称

JOB TITLE
项目名称

DRAWING TITLE
图名

GCB1602E V1.1



8.1 Interface

Pin Assignment

PIN NO.	Symbol	Level	Function
1	V _{DD}	5.0V	Power supply voltage for LCM(+)
2	V _{SS}	0V	Ground
3	V ₀	----	Contrast Adjust
4	RS	H/L	Register select signal
5	R/W	H/L	Data read / write
6	E	H/L	Enable signal
7	DB0	H/L	Data bus line
8	DB1	H/L	Data bus line
9	DB2	H/L	Data bus line
10	DB3	H/L	Data bus line
11	DB4	H/L	Data bus line
12	DB5	H/L	Data bus line
13	DB6	H/L	Data bus line
14	DB7	H/L	Data bus line

9. Block diagram

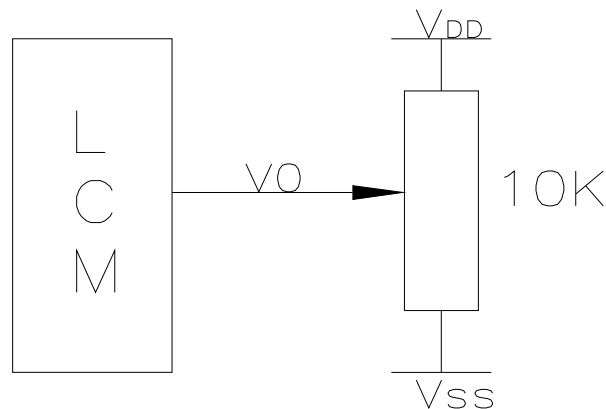
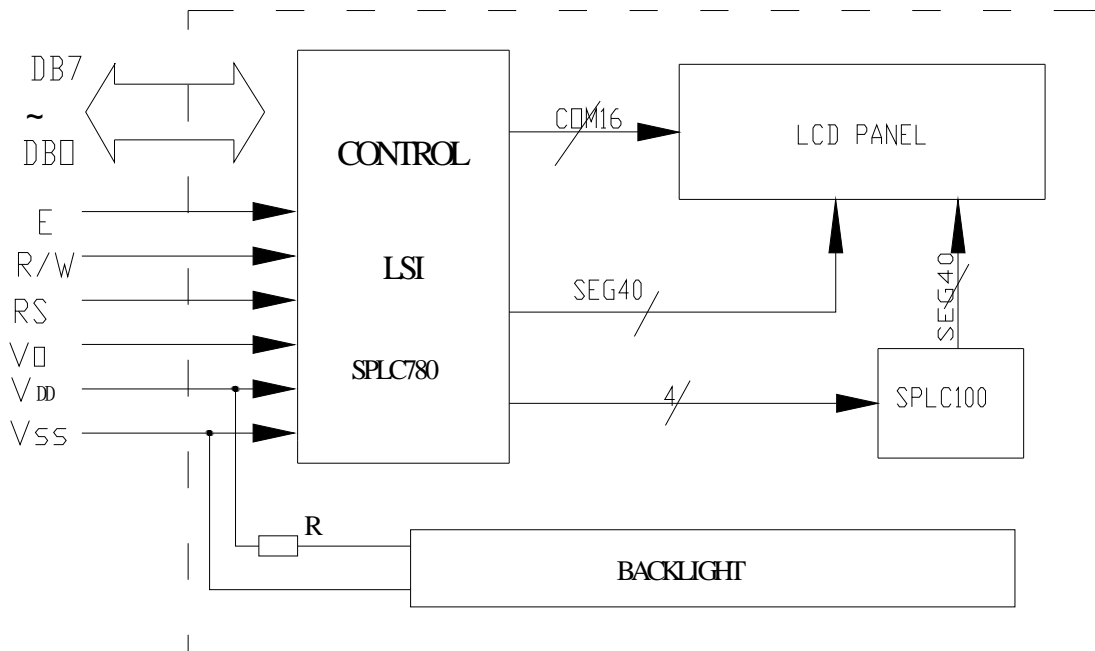

10. Interface Timing Chart

AC Characteristics ($V_{DD}=4.5V\sim 5.5V, T_a=-30\sim +85^{\circ}C$)

Mode	Characteristic	Symbol	Min.	Typ.	Max.	Unit
Write Mode (Refer to Fig-6)	E Cycle Time	t_c	500	-	-	ns
	E Rise / Fall Time	t_R, t_F	-	-	20	
	E Pulse Width (High, Low)	t_w	230	-	-	
	R/W and RS Setup Time	t_{su1}	40	-	-	
	R/W and RS Hold Time	t_{H1}	10	-	-	
	Data Setup Time	t_{su2}	80	-	-	
	Data Hold Time	t_{H2}	10	-	-	
Read Mode (Refer to Fig-7)	E Cycle Time	t_c	500	-	-	ns
	E Rise / Fall Time	t_R, t_F	-	-	20	
	E Pulse Width (High, Low)	t_w	230	-	-	
	R/W and RS Setup Time	t_{su}	40	-	-	
	R/W and RS Hold Time	t_H	10	-	-	
	Data Output Delay Time	t_D	-	-	120	
	Data Hold Time	t_{DH}	5	-	-	

Timing Characteristics

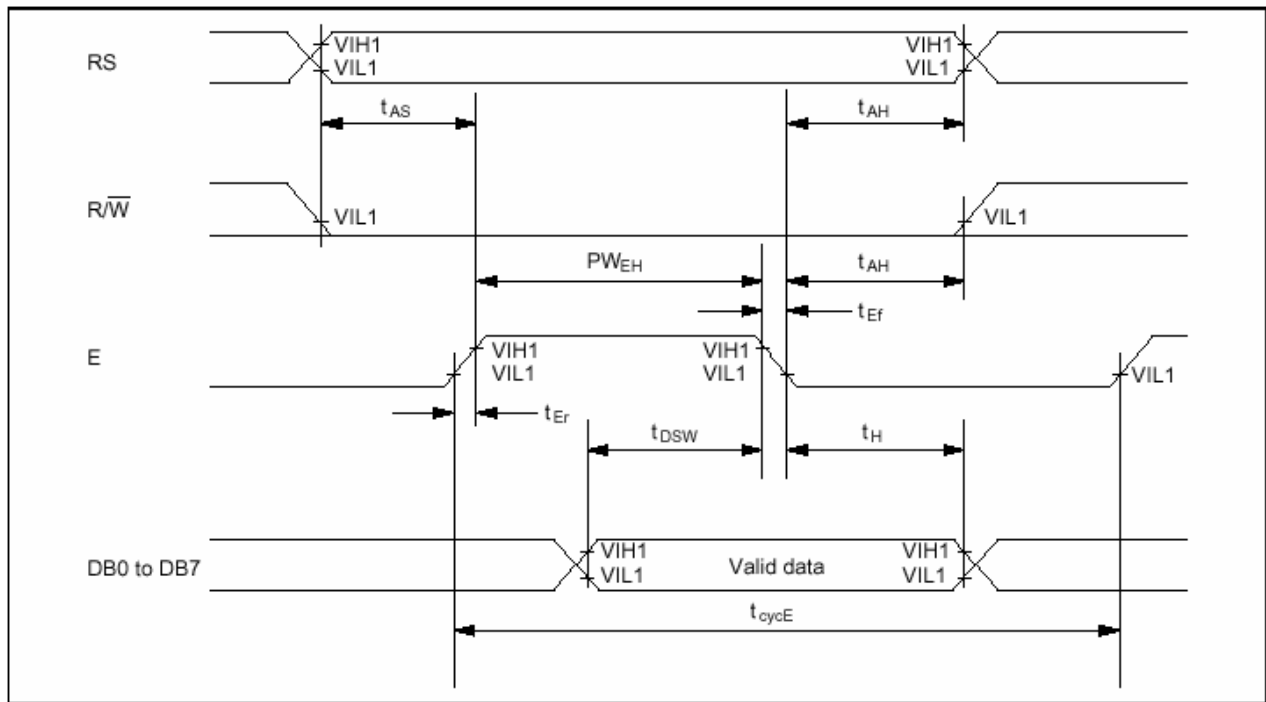

Write Operation

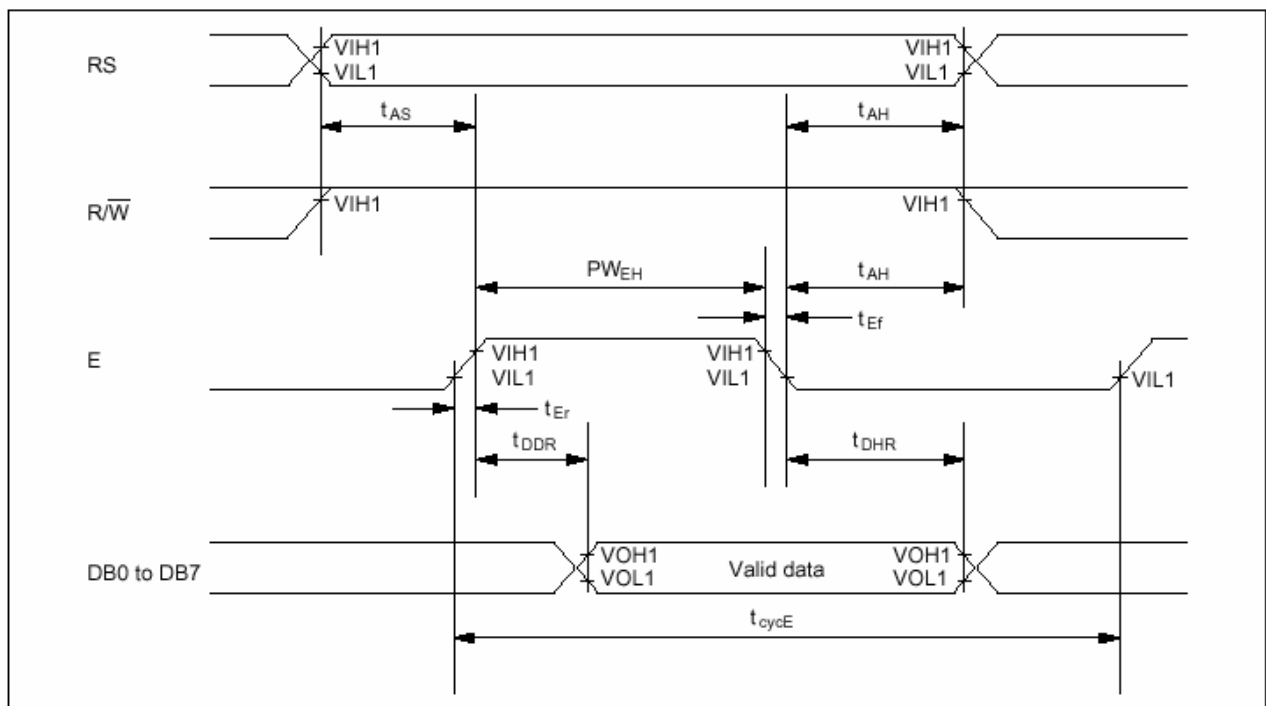

Read Operation

11. Instruction Code

Instruction Table

Instruction	Instruction Code										Description	Execution time (fosc= 270 kHz)	
	RS	R/W	DB7	DB6	DB5	DB4	DB3	DB2	DB1	DB0			
Clear Display	0	0	0	0	0	0	0	0	0	1	Write "20H" to DDRAM and set DDRAM address to "00H" from AC	1.53 ms	
Return Home	0	0	0	0	0	0	0	0	0	1	-	Set DDRAM address to "00H" from AC and return cursor to its original position if shifted. The contents of DDRAM are not changed.	1.53 ms
Entry Mode Set	0	0	0	0	0	0	0	0	1	I/D	SH	Assign cursor moving direction and enable the shift of entire display.	39 μs
Display ON/OFF Control	0	0	0	0	0	0	0	1	D	C	B	Set display(D), cursor(C), and blinking of cursor(B) on/off control bit.	39 μs
Cursor or Display Shift	0	0	0	0	0	0	1	S/C	R/L	-	-	Set cursor moving and display shift control bit, and the direction, without changing of DDRAM data.	39 μs
Function Set	0	0	0	0	0	1	DL	N	F	-	-	Set interface data length (DL: 8-bit/4-bit), numbers of display line (N: 2-line/1-line) and, display font type (F:5×11dots/5×8 dots)	39 μs
Set CGRAM Address	0	0	0	1	AC5	AC4	AC3	AC2	AC1	AC0		Set CGRAM address in address counter.	39 μs
Set DDRAM Address	0	0	1	AC6	AC5	AC4	AC3	AC2	AC1	AC0		Set DDRAM address in address counter.	39 μs
Read Busy Flag and Address	0	1	BF	AC6	AC5	AC4	AC3	AC2	AC1	AC0		Whether during internal operation or not can be known by reading BF. The contents of address counter can also be read.	0 μs
Write Data to RAM	1	0	D7	D6	D5	D4	D3	D2	D1	D0		Write data into internal RAM (DDRAM/CGRAM).	43 μs
Read Data from RAM	1	1	D7	D6	D5	D4	D3	D2	D1	D0		Read data from internal RAM (DDRAM/CGRAM).	43 μs

* "-": don't care

NOTE: When an MPU program with checking the Busy Flag(DB7) is made, it must be necessary 1/2Fosc is necessary for executing the next instruction by the falling edge of the 'E' signal after the Busy Flag (DB7) goes to "Low".

DISPLAY CHARACTER ADDRESS CODE

Display position:	1	2	3	4	5	6	7	8	9	10	11	12	13	14	15	16		
Address line1:	00	01	02	03	04	05	06	07	08	09	0A	0B	0C	0D	0E	0F		
Address line2:	40	41	42	43	44	45	46	47	48	49	4A	4B	4C	4D	4E	4F		

8-bit interface mode (Condition: fosc = 270KHZ)

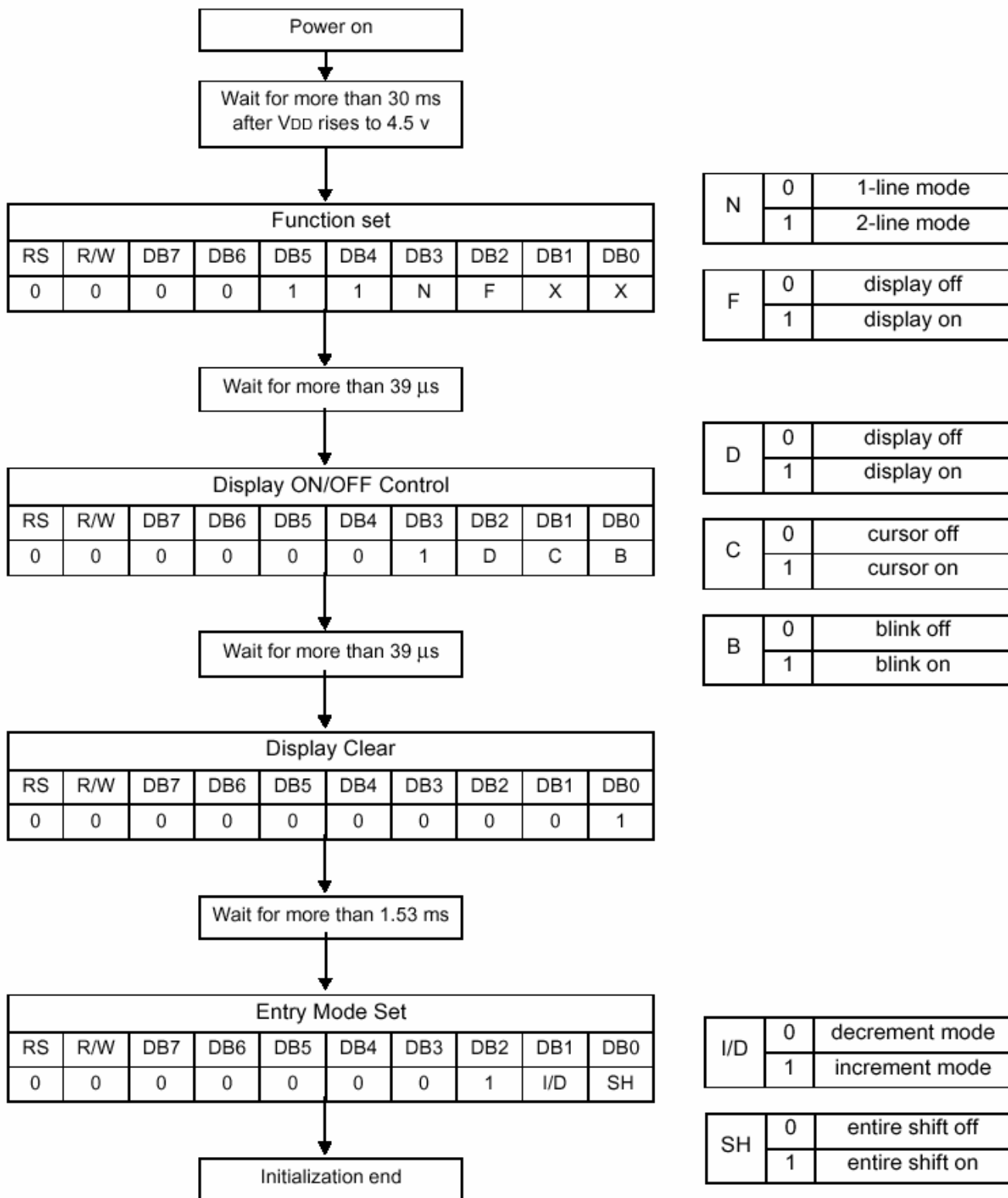

12.Character generator ROM

Lower 4 Bits	Upper 4 Bits	0000	0010	0011	0100	0101	0110	0111	1010	1011	1100	1101	1110	1111
		xxxx0000	CG RAM (1)		Ø	Q	P	`	P		-	タ	三	α
xxxx0001	(2)	!	1	A	Q	a	q	。	ア	チ	△	ä	g	
xxxx0010	(3)	"	2	B	R	b	r	「	イ	ツ	×	β	θ	
xxxx0011	(4)	#	3	C	S	c	s	」	ウ	テ	ε	ε	ω	
xxxx0100	(5)	\$	4	D	T	d	t	、	エ	ト	ト	μ	Ω	
xxxx0101	(6)	%	5	E	U	e	u	・	オ	ナ	1	ε	ü	
xxxx0110	(7)	&	6	F	V	f	v	ヲ	カ	ニ	ヨ	ρ	Σ	
xxxx0111	(8)	'	7	G	W	g	w	ア	キ	ヌ	ラ	g	π	
xxxx1000	(1)	(8	H	X	h	x	イ	ク	ネ	リ	r	×	
xxxx1001	(2))	9	I	Y	i	y	ウ	ケ	ル		'	y	
xxxx1010	(3)	*	:	J	Z	j	z	エ	コ	ン	レ	j	〒	
xxxx1011	(4)	+	;	K	C	k	c	オ	サ	ヒ	ロ	*	万	
xxxx1100	(5)	,	<	L	¥	1	1	パ	シ	フ	ワ	φ	円	
xxxx1101	(6)	-	=	M	J	m	j	ユ	ス	ハ	ン	も	÷	
xxxx1110	(7)	.	>	N	^	n	→	ヨ	セ	ホ	°	ñ		
xxxx1111	(8)	/	?	O	_	o	+	ッ	ソ	マ	°	ö	■	

13. Specification of quality assurance

AQL inspection standard

Sampling method: MIL-STD-105E, Level II, single sampling

Defect classification (**Note: * is not including**)

Classify	Item	Note	AQL	
Major	Display state	Short or open circuit	1	0.65
		LC leakage		
		Flickering		
		No display		
		Wrong viewing direction		
		Contrast defect (dim, ghost)		
	Non-display	Back-light	1,8	
		Flat cable or pin reverse	10	
		Wrong or missing component	11	
Minor	Display state	Background color deviation	2	1.0
		Black spot and dust	3	
		Line defect, Scratch	4	
		Rainbow	5	
		Chip	6	
		Pin hole	7	
	Polarizer	Protruded	12	
		Bubble and foreign material	3	
	Soldering	Poor connection	9	
	Wire	Poor connection	10	
	TAB	Position, Bonding strength	13	

Note on defect classification

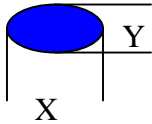
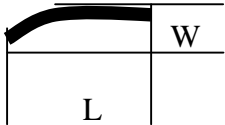
No.	Item	Criterion			
1	Short or open circuit	Not allow			
	LC leakage				
	Flickering				
	No display				
	Wrong viewing direction				
	Wrong Back-light				
2	Contrast defect	Refer to approval sample			
	Background color deviation				
3	Point defect, Black spot, dust (including Polarizer) $\phi = (X+Y)/2$		Point Size	Acceptable Qty.	
			$\phi < 0.10$	Disregard	
			$0.10 < \phi \leq 0.20$	3	
			$0.20 < \phi \leq 0.25$	2	
			$0.25 < \phi \leq 0.30$	1	
			$\phi > 0.30$	0	
Unit:mm					
4	Line defect, Scratch		Line		Acceptable Qty.
			L	W	
			---	$0.015 \geq W$	Disregard
			$3.0 \geq L$	$0.03 \geq W$	2
			$2.0 \geq L$	$.05 \geq W$	
			$1.0 \geq L$	$0.1 > W$	1
---	$0.05 < W$	Applied as point defect			
5	Rainbow	Not more than two color changes across the viewing area.			

NO.	Item	Criterion
-----	------	-----------

6

Chip

Remark:

X: Length direction

Y: Short direction

Z: Thickness direction

t: Glass thickness

W: Terminal Width

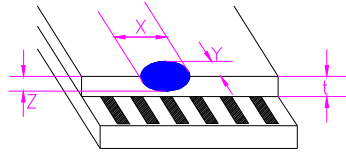

Acceptable criterion		
X	Y	Z
≤ 2	0.5mm	$\leq t/2$

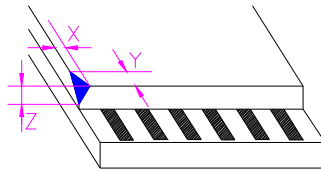

Acceptable criterion		
X	Y	Z
≤ 2	0.5mm	$\leq t$

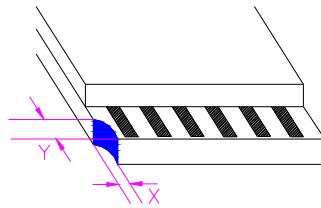

Acceptable criterion		
X	Y	Z
≤ 3	≤ 2	$\leq t$
shall not reach to ITO		

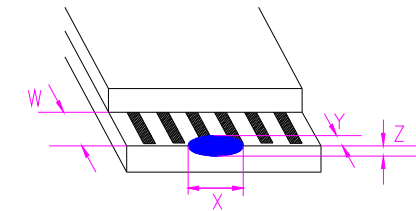

Acceptable criterion		
X	Y	Z
Disregard	≤ 0.2	$\leq t$

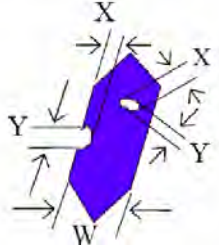
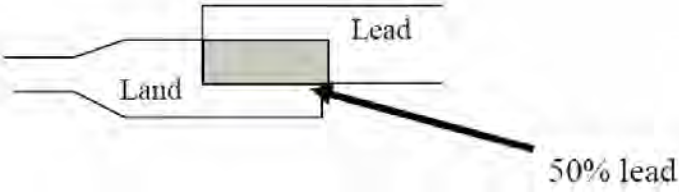
7	Segment pattern $W = \text{Segment width}$ $\phi = (X+Y)/2$	(1) Pin hole $\phi < 0.10\text{mm}$ is acceptable.  <table border="1" data-bbox="1029 212 1468 380"> <thead> <tr> <th>Point Size</th> <th>Acceptable Qty</th> </tr> </thead> <tbody> <tr> <td>$\phi \leq 1/4W$</td> <td>Disregard</td> </tr> <tr> <td>$1/4W < \phi \leq 1/2W$</td> <td>1</td> </tr> <tr> <td>$\phi > 1/2W$</td> <td>0</td> </tr> </tbody> </table> <p style="text-align: center;">Unit: mm</p>	Point Size	Acceptable Qty	$\phi \leq 1/4W$	Disregard	$1/4W < \phi \leq 1/2W$	1	$\phi > 1/2W$	0
Point Size	Acceptable Qty									
$\phi \leq 1/4W$	Disregard									
$1/4W < \phi \leq 1/2W$	1									
$\phi > 1/2W$	0									
8	Back-light	(1) The color of backlight should correspond its specification. (2) Not allow flickering								
9	Soldering	(1) Not allow heavy dirty and solder ball on PCB. (The size of dirty refer to point and dust defect) (2) Over 50% of lead should be soldered on Land. 								
10	Wire	(1) Copper wire should not be rusted (2) Not allow crack on copper wire connection. (3) Not allow reversing the position of the flat cable. (4) Not allow exposed copper wire inside the flat cable.								
11*	PCB	(1) Not allow screw rust or damage. (2) Not allow missing or wrong putting of component.								

NO.	Item	Criterion
-----	------	-----------

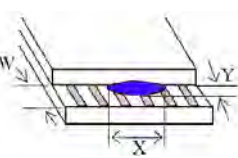
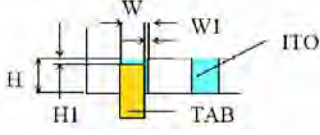
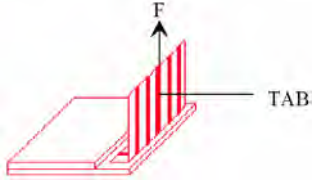
12	Protruded W: Terminal Width	 <p>Acceptable criteria: $Y \leq 0.4$</p>
13	TAB	<p>1. Position</p>  <p>$W1 \leq 1/3W$ $H1 \leq 1/3H$</p> <p>2 TAB bonding strength test</p>  <p>$P (=F/TAB \text{ bonding width}) \geq 650\text{gf/cm}$, (speed rate: 1mm/min) 5pcs per SOA (shipment)</p>
14	Total no. of acceptable Defect	<p>A. Zone Maximum 2 minor non-conformities per one unit. Defect distance: each point to be separated over 10mm</p> <p>B. Zone It is acceptable when it is no trouble for quality and assembly in customer's end product.</p>