

GigaDevice Semiconductor Inc.

**GD30BC2501x
Multi-Cell Battery Charger**

Datasheet

Table of Contents

Table of Contents	2
List of Figures	4
List of Tables	5
1 Features	6
2 Applications	6
3 General description	7
4 Device overview	8
4.1 Device information	8
4.2 Block diagram	8
4.3 Pinout and pin assignment	9
4.4 Pin definitions	9
5 Functional description	11
5.1 Operation	11
5.2 Charging Control	11
5.2.1 Charge cycle	11
5.2.2 Charge state diagram	12
5.2.3 Charge parameters	12
5.3 LDO 3.3V	13
5.4 NTC battery temperature	13
5.5 STAT1/STAT2	13
5.6 Thermal shutdown	13
5.7 Recommended device selection	14
5.7.1 Inductor selection	14
5.7.2 Input VCC capacitor selection	14
5.8 I2C interface	15
5.9 Register Map	15
5.9.1 Fault Register	15
5.9.2 Control Register	16
5.9.3 User configure Register	17
6 Electrical characteristics	18
6.1 Absolute maximum ratings	18



6.2	Recommended operation conditions	18
6.3	Electrical sensitivity	18
6.4	Power supplies voltage and current.....	19
6.5	Logic input and open drain output characteristics.....	19
6.6	Switching control characteristics	19
6.7	NTC characteristics and thermal protection.....	20
6.8	I2C characteristics	20
7	Typical application circuit	22
8	Layout guideline	23
9	Package information.....	24
9.1	QFN16 package outline and dimensions	24
9.2	Thermal characteristics	26
10	Ordering information.....	27
11	Revision history.....	28

List of Figures

Figure 4-1 Block diagram for GD30BC2501x	8
Figure 4-2 GD30BC2501x QFN16 pinouts	9
Figure 5-1 Battery charge cycle	12
Figure 5-2 Battery charge state diagram.....	12
Figure 5-3 I2C communication flow	15
Figure 6-1. I2C bus timing diagram.....	21
Figure 7-1 Typical GD30BC2501x application circuit.....	22
Figure 8-1 Typical GD30BC2501x layout guideline	23
Figure 9-1 QFN16 package outline.....	24
Figure 9-2 QFN16 recommend footprint.....	25

List of Tables

Table 4-1 Device information for GD30BC2501x	8
Table 4-2 GD30BC2501x pin definitions	9
Table 5-1 LED state for GD30BC2501x	13
Table 5-2 Inductor recommended selection.....	14
Table 5-3 VCC capacitor recommended selection	14
Table 6-1 Absolute maximum ratings	18
Table 6-2 Recommended operation conditions.....	18
Table 6-3 Electrostatic Discharge characteristics.....	19
Table 6-4 Power supplies voltages and currents	19
Table 6-5 Logic input and open drain output characteristics	19
Table 6-6 Linear charger characteristics.....	19
Table 6-7 NTC characteristics and thermal protection	20
Table 6-8 I2C characteristics	20
Table 9-1 QFN16 package dimensions	24
Table 9-2 Package thermal characteristics ⁽¹⁾	26
Table 10-1 Part order code for GD30BC2501x	27
Table 11-1 Revision history	28

1 Features

- Charge 4/6 cell Li-ion battery packs with wide input operation voltage up to 32V
- Charging features
 - Full charge cycle: pre-charge, constant current and constant voltage
 - Switching charging up to 5A
 - Charging current programmable with sensing resistor
 - Support variety of battery chemistries, 4.1/4.2/4.3/4.35V @1%
- Protection features
 - Cycle-by-Cycle Over Current Protection
 - Battery Over/Under temperature protection
 - Over voltage (OV) during charge
 - Under voltage (UV) when charge/discharge
 - Thermal Shutdown
- Additional features
 - High charging efficiency up to 95%
 - Fixed switching frequency 500KHz
 - Charging status indicator
 - Internal charging timing
 - Low external component count
 - I2C communication protocol

2 Applications

- Notebook
- Clean robots
- Aeromodelling, Drones
- Chargers for 4/6 series cell Li-ion battery

3 General description

The GD30BC2501x is a highly integrated low quiescent current switching battery charger control IC for 4/6 series cell Li-ion battery packs. It drives an external N-MOSFET that can output a charge current up to 5A through a sensing resistor and has a very high efficiency up to 90%. The battery voltage is regulated to very high precision (less than +/- 1%). The device operates with wide input range up to 32V. It has peak-current-mode control for fast loop response and easy compensation.

Two control loops, constant current (CC) and constant voltage (CV) are implemented in the GD30BC2501x. The constant current is programmable up to 5A and regulated using a sense resistor. The constant voltage is precisely regulated internally.

The device includes multiple protection features such as cycle-by-cycle current limiting, under voltage lockout and thermal shutdown. Other protection features include battery temperature monitoring and protection, charge status indication and internal timer to stop the charging cycle.

The GD30BC2501x has a small footprint of QFN16 (4mmx4mm) and requires a minimal number of external components allowing for it to best used in clean robots, drones or any 4/6 cell Li-ion battery chargers.

4 Device overview

4.1 Device information

Table 4-1 Device information for GD30BC2501x

Part Order Code	Package	Description
GD30BC2501LRTR	QFN16	Cooperate with MCU solution, 4/6 cells

4.2 Block diagram

Figure 4-1 Block diagram for GD30BC2501x

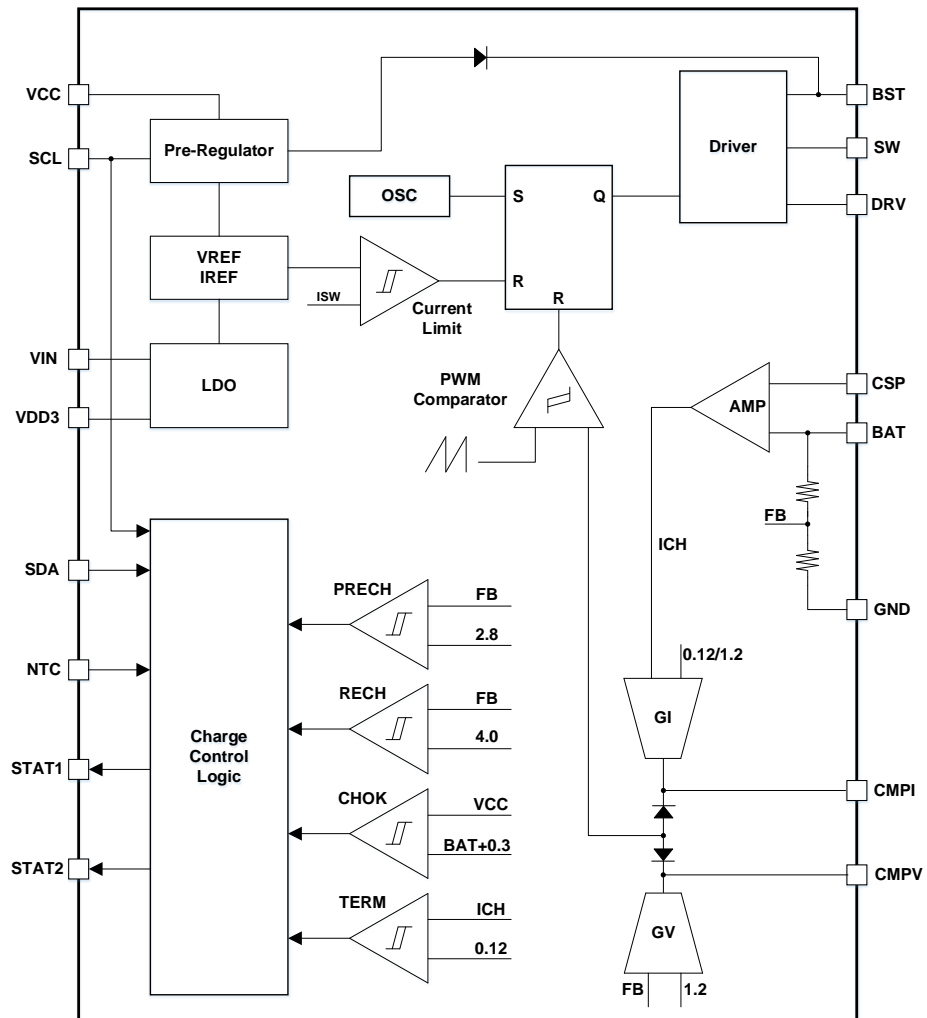

4.3 Pinout and pin assignment

Figure 4-2 GD30BC2501x QFN16 pinouts

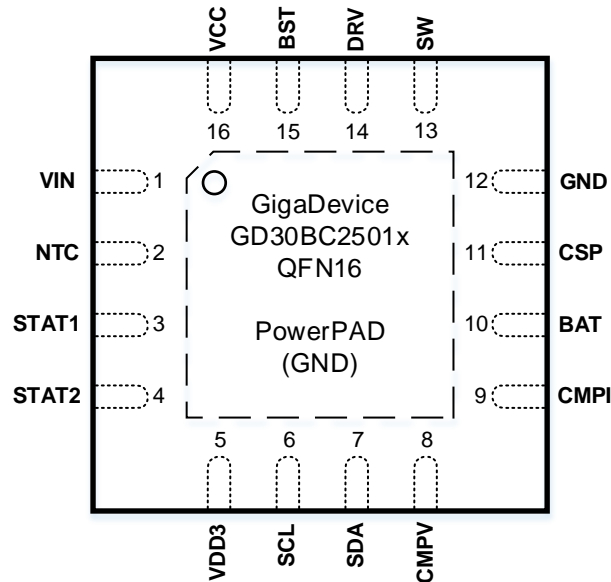

4.4 Pin definitions

Table 4-2 GD30BC2501x pin definitions

Pin Name	Pins	Pin Type	Functions description
VIN	1	P	Input voltage, bypass to ground with a 4.7uF capacitor.
NTC	2	I	Thermistor terminal voltage for battery.
STAT1	3	OD	Open drain charging status indication 1.
STAT2	4	OD	Open drain charging status indication 2.
VDD3	5	O	3.3V LDO output, connect a 1uF capacitor to ground.
SCL	6	I/O	SCL for I2C communication.
SDA	7	I/O	SDA for I2C communication.
CMPV	8	O	Compensation for constant voltage charge control.
CMPI	9	O	Compensation for constant current charge control.
BAT	10	I	Connect to positive battery node for voltage/current sensing.
CSP	11	I/O	Connect to sensor resistor as current sense positive input.
GND	12	G	Ground.
SW	13	O	Switching node, connecting to CSP by an inductor.
DRV	14	P	Drive the gate of the external N-MOSFET.

Pin Name	Pins	Pin Type	Functions description
BST	15	P	Bootstrap voltage, connect to SW with a 0.1uF capacitor.
VCC	16	P	Supply voltage, connect a capacitor to ground; could connect to VIN with diode.
PGND	EPAD	G	Device power ground.

Notes:

1. Type: I = input, O = output, I/O = input or output, P = power, G = Ground, OD = Open Drain.

5 Functional description

5.1 Operation

When power is ready (V_{CC}/V_{IN} above the UVLO threshold and $V_{CC}-V_{BAT} > 0.3V$), the GD30BC2501x pulls the DRV high to turn on the external N-MOSFET, connecting SW and inductor to power supply and begins the charging process. If V_{CC}/V_{IN} is above UVLO, but $V_{CC}-V_{BAT}$ is less than 0.3V, the IC enters sleep mode.

As the inductor current increases and reaches the current limit, the RS flip-flop resets the driver and DRV is pulled low and the external N-MOSFET is turned off. An external Schottky diode then conducts the inductor current.

Depending on the BAT voltage, the IC enters different charging status respectively: pre-charge, constant current charge and constant voltage charge. Pre-charge and constant current charge share one current control loop which is compensated with an external RC network at CMPI. A constant voltage charge control takes over when the battery voltage is charged up to the reference voltage. It also requires a compensation circuit at CMPV. The normal charge process will be stopped if the charge current falls below an internally-set current level (I_{TER}) during constant voltage charge.

The charging process will be terminated if a fault condition is triggered. The fault conditions include: battery under/over temperature; supply under voltage lockout; battery over charge; thermal shutdown; charging timer out.

5.2 Charging Control

5.2.1 Charge cycle

The GD30BC2501x is a switching charger that allows the battery to be charged with a programmable charge current up to 5A. The regulation voltage can be programmed to 16.8V (4-cell) or 25.2V (6-cell) through I2C interface. A complete charge cycle shown in Figure 5-1 is implemented in the device.

When V_{BAT} is lower than V_{PCH} , charge starts from pre-charge. Pre-charge current I_{PCH} is set to the 1/10 of the current I_{CCCH} which is determined by the sense resistor R_{SEN} . After V_{BAT} is charged to be above V_{PCH} , a constant current control loop takes over and the charging current is set to I_{CCCH} . Constant current charge lasts until V_{BAT} reaches the regulated voltage V_{CVCH} . By then a constant voltage control takes over and the charge current gradually decreases while the output voltage is fixed at V_{CVCH} . The charge process stops when the charge current is reduced to a termination current I_{TER} , which is set to equal to I_{PCH} in the device. When the battery voltage drops to V_{RCH} , the whole charge process will resume.

Figure 5-1 Battery charge cycle

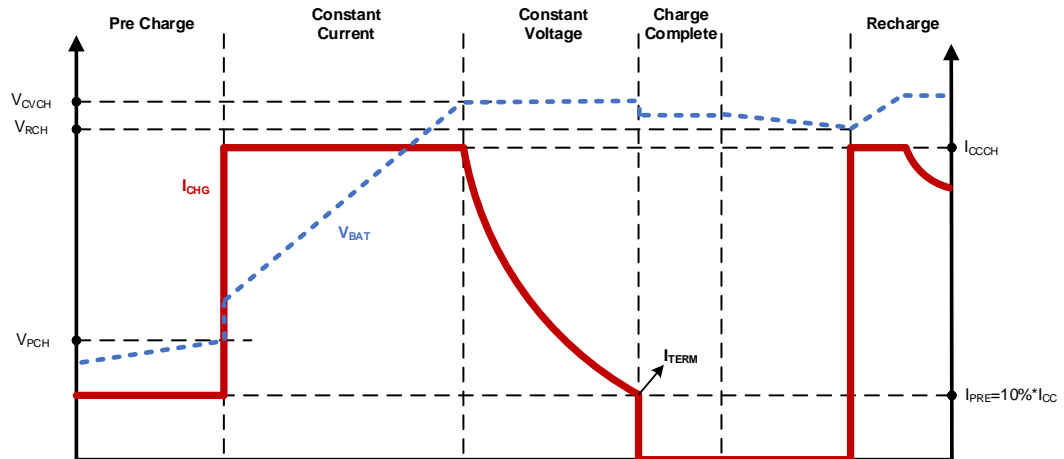

5.2.2 Charge state diagram

The normal charge state diagram is shown in Figure 5-2. The fault conditions besides timer out include thermal shutdown, battery temperature through NTC monitoring, and supply under voltage lockout. All fault conditions are always monitored in the charging process. Any fault will halt the charging process and can only be reset by power-on.

Figure 5-2 Battery charge state diagram

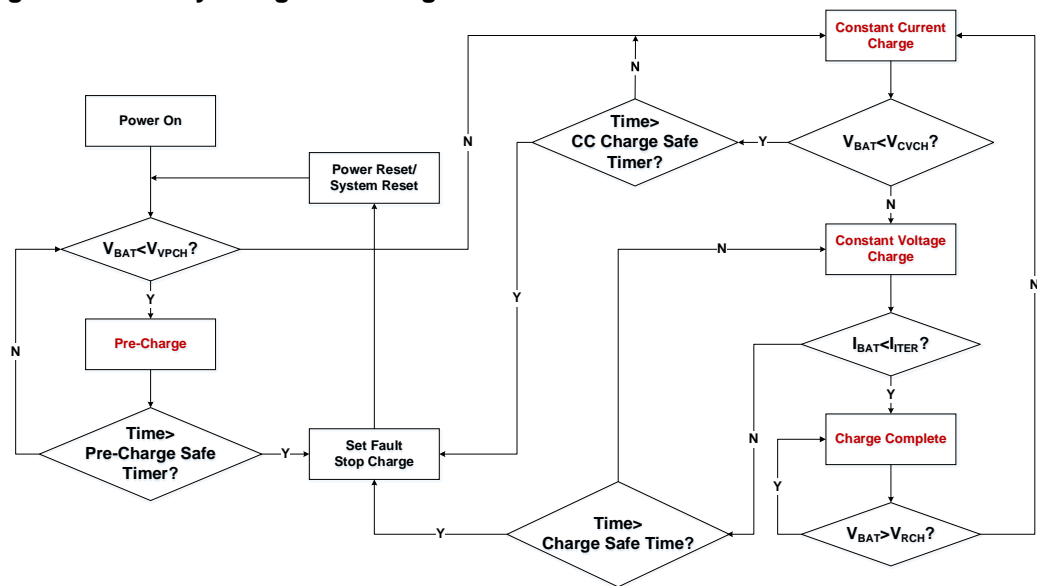

5.2.3 Charge parameters

The maximum charge current through the external N-MOSFET is programmed by a sense resistor connected from the CSP to BAT. The resistor value and the maximum current are related by:

$$R_{SEN} \times I_{CCCH} = 200 \text{ mV}$$

Where I_{CCCH} is the targeted maximum charge current in A and R_{SEN} is the sense resistor. And the pre-charge current and termination charge current is determined internally by:

$$I_{PCH} = I_{TER} = \frac{1}{10} I_{CCCH}$$

5.3 LDO 3.3V

The GD30BC2501x has an internal 3.3V LDO VDD3 to power the internal circuitry. VDD3 can also provide up to 3.3V/ 25mA current for external circuitry. Connect a 1uF bypass capacitor from VDD3 to GND to ensure stability.

5.4 NTC battery temperature

A built-in NTC resistance window comparator that allows the GD30BC2501x to sense the battery temperature through the thermistor included in the battery pack. Connect a resistor with an appropriate value from VDD3 to NTC and connect the thermistor from NTC to GND. A resistor divider determines the voltage on NTC as a function of the battery temperature. Charging will stop or resume when the voltage is within or out of the NTC window.

5.5 STAT1/STAT2

STAT1/STAT2 are two open-drain status output which are used to indicate the charging status. Table 5-1 shows the charging status indications.

Table 5-1 LED state for GD30BC2501x

STAT1	STAT2	Charging Indication
LOW	LOW	In Charging
LOW	HIGH	End of Charge, or NTC Fault, or Timer Out, or Thermal Shutdown
HIGH	HIGH	VCC-VBAT < 0.3V, or VIN < UVLO, or VBAT < 4.8V

5.6 Thermal shutdown

If the die temperature exceeds the trip point of the thermal shutdown limit (T_{SD}), the charge process will be terminated and the external N-MOSFET are disabled. The fault condition will be shown in STAT1/STAT2. The charging cycle will be resumed when the die temperature is reduced below the thermal shutdown limit (with a hysteresis).

5.7 Recommended device selection

5.7.1 Inductor selection

During normal operation, the transient inductor current changes periodically. During the turn-on period of the N-MOS field effect transistor, the input voltage charges the inductor and the inductor current increases; during the turn-off period of the N-MOS field effect transistor, the inductor discharges to the battery and the inductor current decreases. The ripple current of the inductor increases with the decrease of the inductance value and increases with the increase of the input voltage. Larger inductor ripple current will cause larger ripple charging current and magnetic loss. Therefore, the ripple current of the inductor should be limited within a reasonable range. The inductor value can be calculated:

$$L = \frac{V_{BAT}}{f_{sw} \times I_{PP}} \times \left(1 - \frac{V_{BAT}}{V_{IN(MAX)}} \right)$$

Where

- f_{sw} is the switching frequency, fixed value $f_{sw} = 500\text{kHz}$, unit Hz.
- I_{PP} is the maximum ripple current, unit A.
- V_{IN} is the maximum input voltage, unit V.
- V_{BAT} is the battery voltage, unit V.

When selecting the inductor value, the inductor ripple current can be limited to 40 percent of charging current. For the selection of inductor value when $V_{IN} = 24\text{V}$, $V_{BAT} = 16\text{V}$, refer to Table 5-2.

Table 5-2 Inductor recommended selection

Charging Current	Inductor value
1A	36uH
2A	27uH
3A	22uH
4A	15uH
5A	10uH

5.7.2 Input VCC capacitor selection

With the increase of charging current, the input current fluctuation of power supply is also increasing. In order to ensure the stability of VCC power supply, the capacitance of VCC filter capacitor also needs to be increased. For the selection of capacitor value when $V_{IN} = 24\text{V}$, $V_{BAT} = 16\text{V}$, refer to Table 5-3.

Table 5-3 VCC capacitor recommended selection

Charging Current	Capacitor selection
1A	4.7uF
2A	10uF

3A	22uF
4A	33uF
5A	47uF

5.8 I2C interface

I2C interface is included only in GD30BC2501x.

The I2C (inter-integrated circuit) module provides an I2C interface which is an industry standard two-line serial interface for MCU to communicate with external I2C interface. I2C bus uses two serial lines: a serial data line, SDA, and a serial clock line, SCL.

The I2C interface implements standard I2C protocol with standard-mode (up to 100 kHz) and fast-mode (up to 400 kHz). The I2C interface only supports Slave-mode. The I2C interface receive data on rising SCL and transmit data on falling SCL.

Figure 5-3 I2C communication flow

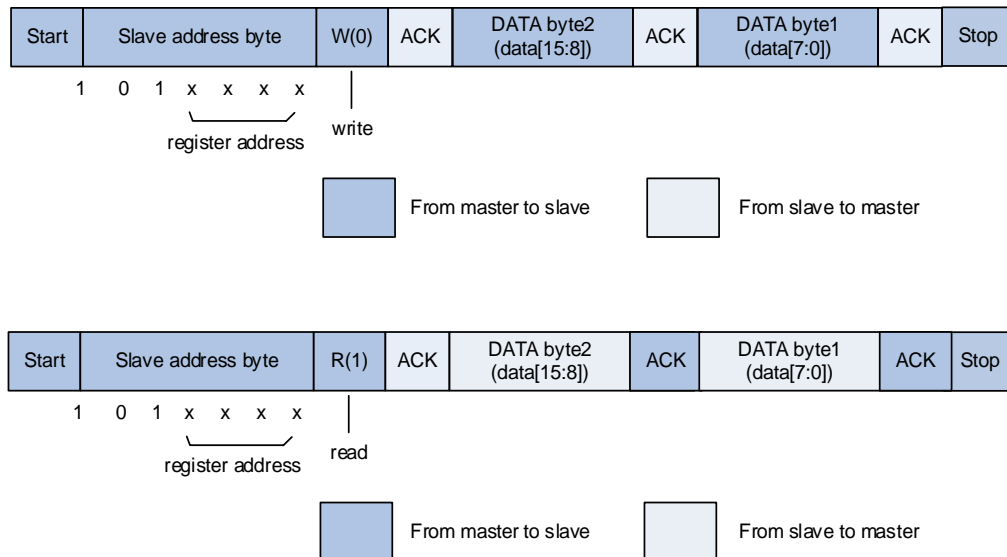

The data format is fixed:

8bit function (3'b101 + 4bit(register address), +1bit(1'b0-write, 1'b1-read))
+ 8bit data[15:8]
+8bit data[7:0].

5.9 Register Map

5.9.1 Fault Register

Address: 0b 0000

Bits	R/W	fields	default	Description
15:7	R	Reserved	0b0	Must be kept at reset value.

Bits	R/W	fields	default	Description
6	R	VBAT_OV_FAULT	0b0	VBAT overvoltage fault event indicator. 0: normal 1: VBAT over voltage fault is detected
5	R	TO_FAULT	0b0	Full charge TIME_OUT fault event indicator. (Can be Cleared by writing control register ENB_REG = 0). 0: normal 1: Time out fault is detected
4	R	TO_PCH_FAULT	0b0	Pre-charge TIME OUT. (Can be Cleared by writing control register ENB_REG = 0). 0: normal 1: Pre-charge time out fault is detected
3	R	Reserved	0b0	Must be kept at reset value.
2	R	NTC_HOT_FAULT	0b0	NTC high temperature fault event indicator. 0: normal 1: NTC high temperature fault is detected
1	R	NTC_COLD_FAULT	0b0	NTC low temperature fault event indicator. 0: normal 1: NTC low temperature fault is detected
0	R	TEMP_FAULT	0b0	Battery over temperature fault event indicator. 0: normal 1: Over temperature fault is detected

5.9.2 Control Register

Address: 0b 0001

Bits	R/W	fields	default	Description
15:14	RW	CELLSEL_CF	0b0	Battery cell count selection configuration. 00: 4 Cell Li-ion Batteries 01: 6 Cell Li-ion Batteries 1x: Reserved
13:12	RW	ACOKSEL	0b0	The minimum difference between VCC and VBAT during charging. 00: 300mV 01: 600mV 10: 1.2V 11: 2.4V
11:8	R	Reserved	0b0	Must be kept at reset value.
7	RW	ENB_REG	0b1	IC enable configuration register. 0: Sleep mode 1: Normal working mode
6	RW	RST_ALL	0b0	Reset all registers to default values. 0: No effect

Bits	R/W	fields	default	Description
				1: Reset all chip
5	RW	RST_OTHS	0b0	Reset registers to default values except I2C. 0: No effect 1: Reset all chip but I2C itself
4	R	Reserved	0b0	Must be kept at reset value.
3:2	RW	TIMEOUT_SEL	0b0	Charge status timeout time select. 00: 30min(Pre-charge)/ 180min(All time) 01: 20min(Pre-charge)/ 120min(All time) 10: 40min(Pre-charge)/ 240min(All time) 11: 30min(Pre-charge)/ 180min(All time)
1:0	RW	VBATREG_CF	0b0	Constant current charge terminate voltage configuration. 00: 4.2V 01: 4.1V 10: 4.3V 11: 4.35V

5.9.3 User configure Register

Address: 0b 0011

Bits	R/W	fields	default	Description
15	RW	VBATREG_EN	0b0	VBATREG calibration signal enable. 0: VBATREG_CF disable 1: VBATREG_CF enable
14	RW	CELLSEL_EN	0b0	Cellsel enable. 0: CELLSEL_CF disable 1: CELLSEL_CF enable
13:0	R	Reserved	0b0	Must be kept at reset value.

6 Electrical characteristics

6.1 Absolute maximum ratings

The maximum ratings are the limits to which the device can be subjected without permanently damaging the device. Note that the device is not guaranteed to operate properly at the maximum ratings. Exposure to the absolute maximum rating conditions for extended periods may affect device reliability.

Table 6-1 Absolute maximum ratings

Symbol	Parameter	Min	Max	Unit
V _{IN}	Power supply from adaptor (VIN, VCC)	-0.3	40	V
V _{BAT}	Battery voltage (BAT)	-0.3	40	V
V _{CSP}	Current sense voltage	-0.3	40	V
V _{DRV}	Drive node to external N-MOSFET gate	-0.3	40	V
V _{VDD3}	LDO output voltage	-0.3	5	V
V _{BST}	Bootstrap voltage	-0.3	40	V
V _{SW}	Switching node voltage (SW)	-1	40	V
V _{IO}	I/O pin voltage (NTC, SCL, SDA, CMPI, CMPV)	-0.3	7	V
V _{STAT}	Open drain output STAT1, STAT2	-0.3	40	V
Thermal characteristics				
T _J	Operating junction temperature	-40	125	°C
T _{stg}	Storage temperature	-65	150	°C

6.2 Recommended operation conditions

Table 6-2 Recommended operation conditions

Symbol	Parameter	Min	Max	Unit
V _{IN}	Power supply from adaptor (VIN, VCC)	18	32	V
V _{BAT}	Battery voltage (BAT)	5	—	V
V _{IO}	I/O pin voltage (NTC, SCL, SDA, CMPI, CMPV)	-0.3	5.5	V
V _{STAT}	Open drain output STAT1, STAT2	-0.3	32	V
Thermal characteristics				
T _A	Operating ambient temperature	-40	85	°C

6.3 Electrical sensitivity

The device is strained in order to determine its performance in terms of electrical sensitivity. Electrostatic discharges (ESD) are applied directly to the pins of the sample.

Table 6-3 Electrostatic Discharge characteristics

Symbol	Parameter	Conditions	Value	Unit
$V_{ESD(HBM)}$	human body model	$T_A = 25\text{ }^\circ\text{C}$; JS-001-2017	± 1000	V
$V_{ESD(CDM)}$	charge device model	$T_A = 25\text{ }^\circ\text{C}$; JS-002-2018	± 1000	V

6.4 Power supplies voltage and current

Table 6-4 Power supplies voltages and currents

Symbol	Parameter	Conditions	Min	Typ	Max	Unit
I_Q	Sleep mode quiescent current	$T_A = 25\text{ }^\circ\text{C}$	—	—	100	μA
I_{CC}	Operation current	$T_A = 25\text{ }^\circ\text{C}$	—	2	—	mA
t_{WAKE}	Turn-on time	$V_{USB} > V_{UVLO}$ to outputs ready	1	—	—	ms
V_{VDD3}	LDO regulator voltage	$I_{VDD3} = 0$ to 30 mA	3	3.3	3.6	V
V_{UVLO}	Under voltage lockout	$T_A = 25\text{ }^\circ\text{C}$	—	3.25	—	V
$V_{CC-VBAT}$	—	VCC rise, ACOKSEL = 00	—	0.3	—	V
$V_{CC-VBAT}$	hysteresis	VCC fall	—	0.15	—	V

6.5 Logic input and open drain output characteristics

Table 6-5 Logic input and open drain output characteristics

Symbol	Parameter	Conditions	Min	Typ	Max	Unit
V_{IL}	Input logic low voltage	—	0	—	0.8	V
V_{IH}	Input logic high voltage	—	1.5	—	5.5	V
V_{HYS}	Input logic hysteresis	—	100	—	—	mV
I_{IL}	Input logic low current	$V_{IO} = 0\text{ V}$	-5	—	5	μA
I_{IH}	Input logic high current	$V_{IO} = 3.3\text{ V}$	—	—	5	μA
R_{PD}	Pull down resistance	To GND	—	1	—	M Ω
V_{OD}	Output logic low voltage	$I_{OD} = 10\text{ mA}$	—	—	0.1	V
I_{LK_SDA}	SDA leakage	$V_{SDA} = 3.3\text{ V}$	—	—	2	μA
I_{LK_STAT}	STAT1/2 leakage	$V_{STAT} = 32\text{ V}$	—	—	2	μA

6.6 Switching control characteristics

Table 6-6 Linear charger characteristics

Symbol	Parameter	Conditions	Min	Typ	Max	Unit
V_{CVCH}	Regulated battery voltage	Per cell (4-cell, x4; 6-cell, x6)	4.16	4.20	4.24	V
V_{PCH}	Pre-Charge to charge transition	Per cell (4-cell, x4; 6-cell, x6)	—	3.0	—	V
V_{RCH}	Re-Charge threshold	Per cell (4-cell, x4; 6-cell, x6)	—	4.0	—	V

	Re-Charge hysteresis	—	—	2%	—	V_{RCH}
V_{SEN}	Current sense $V_{CSP} - V_{BAT}$	CC-CV charge	180	200	220	mV
		Pre-charge	18	20	22	mV
I_{CCCH}	Charge current	$R_{SEN}=100m\Omega$	1.80	2.00	2.20	A
I_{PCH}	Pre-Charge/Termination current	—	—	10%	—	I_{CCCH}
I_{LK_SW}	SW leakage current	$V_{SW}=32V$	—	—	2	μA
f_{SW}	Switching frequency	—	450	500	550	KHz
D_{MAX}	Maximum duty cycle	—	—	95	—	%
V_{PU}	Pull up voltage	$V_{DRV} - V_{SW}$	5.4	6	6.6	V
T_R	Pull up rise time	$C_L = 2nF, V_{DRV}$ from 10% to 90%	—	40	—	ns
T_F	Pull down fall time	$C_L = 2nF, V_{DRV}$ from 90% to 10%	—	40	—	ns

6.7 NTC characteristics and thermal protection

Table 6-7 NTC characteristics and thermal protection

Symbol	Parameter	Conditions	Min	Typ	Max	Unit
V_{TL}	NTC low-temp rising threshold	As percentage of VDD3	64	65	66	%
V_{TH}	NTC high-temp falling threshold	As percentage of VDD3	34	35	36	%
T_{SD}	Thermal shutdown temperature	—	—	150	—	$^{\circ}C$
T_{SDHYS}	Thermal shutdown hysteresis	—	—	25	—	$^{\circ}C$

6.8 I2C characteristics

Table 6-8 I2C characteristics

Symbol	Parameter	Conditions	Standard mode		Fast mode		Unit
			Min	Max	Min	Max	
$t_{SCL(H)}$	SCL clock high time	—	4.0	—	0.6	—	μs
$t_{SCL(L)}$	SCL clock low time	—	4.7	—	1.3	—	μs
$t_{su(SDA)}$	SDA setup time	—	250	—	100	—	ns
$t_h(SDA)$	SDA data hold time	—	0	3450	0	900	ns
$t_r(SDA/SCL)$	SDA and SCL rise time	—	—	1000	—	300	ns
$t_f(SDA/SCL)$	SDA and SCL fall time	—	—	300	3	300	ns
$t_h(STA)$	Start condition hold time	—	4.0	—	0.6	—	μs

Figure 6-1. I2C bus timing diagram

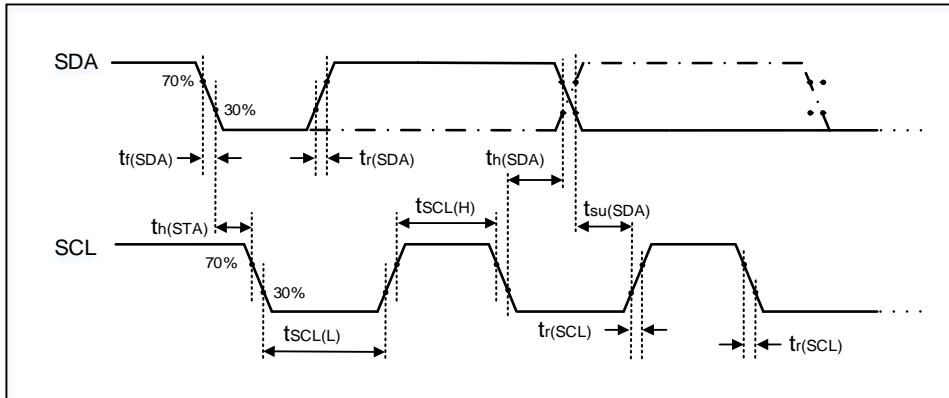

7 Typical application circuit

Figure 7-1 Typical GD30BC2501x application circuit

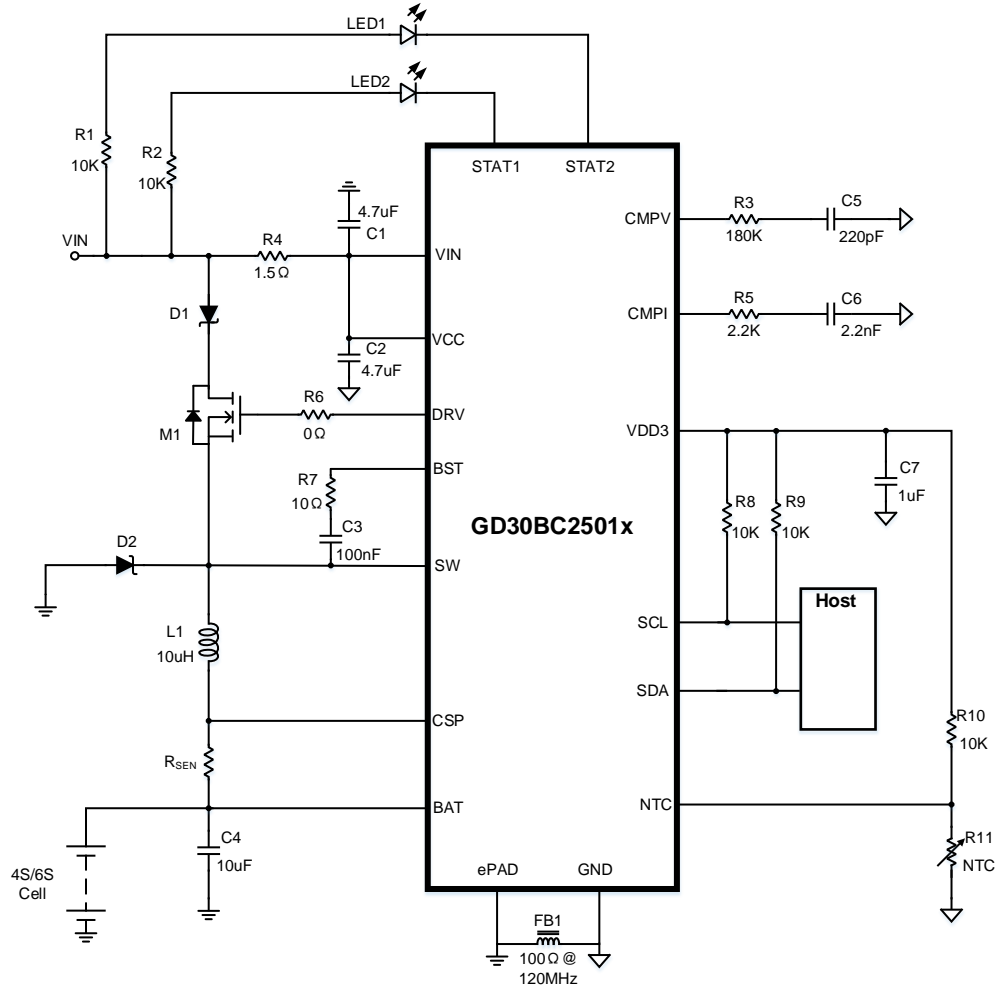

Notes:

1. The values of C2, L1 and R_{SEN} will change according to the change of constant current charging current. Please refer to section 5.7 for specific calculation method. Figure 7-1 shows a typical application circuit with 4 batteries.
2. Resistor R4 and capacitor C1 should be close to VIN pin.

8 Layout guideline

Figure 8-1 Typical GD30BC2501x layout guideline

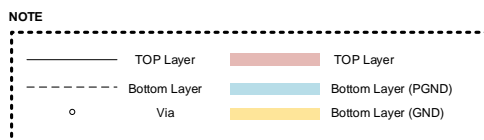
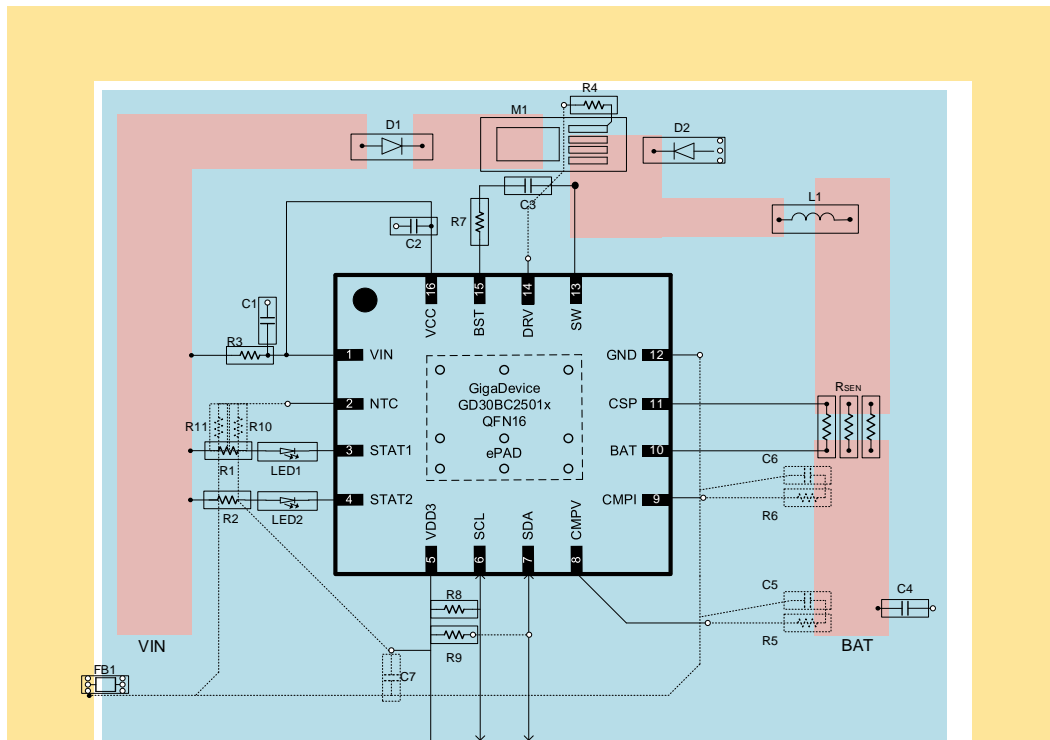

Notes:

1. In buck regulator, the loop area should be minimized as far as possible, which can reduce stray inductance and minimize noise.
2. The MOSFET should be close to the chip as far as possible to reduce the routing length of the driver and SW, so as to reduce the noise.
3. R_{SEN} should be close to the chip to ensure the accuracy of charging current. R_{SEN} suggests that multiple resistors should be connected in parallel to reduce the heat loss of a single resistor.
4. The capacitor C3 should be placed on the top layer to reduce parasitic parameters.

9 Package information

9.1 QFN16 package outline and dimensions

Figure 9-1 QFN16 package outline

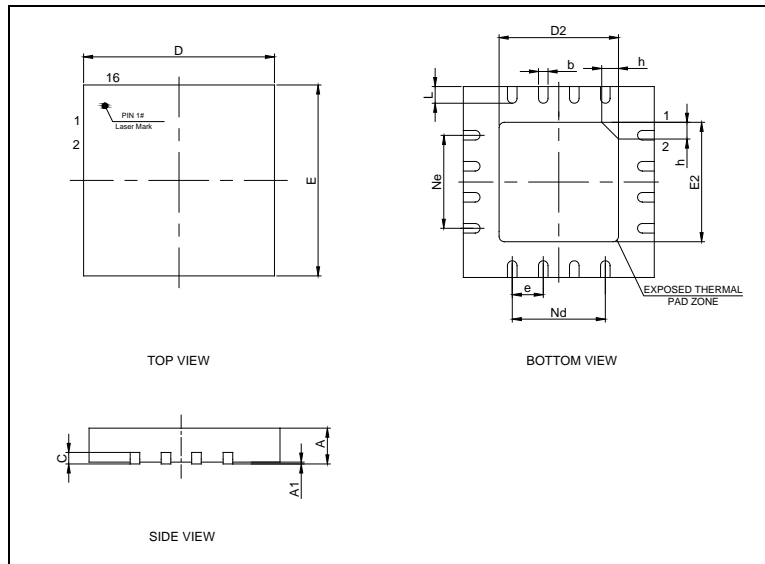
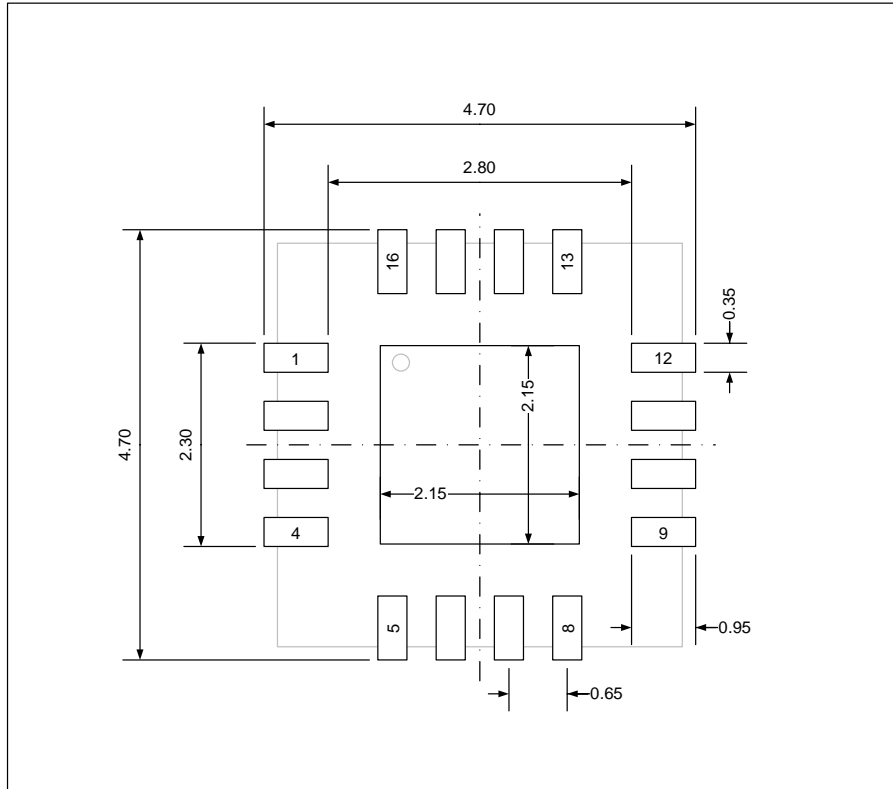

Table 9-1 QFN16 package dimensions

Symbol	Min	Typ	Max
A	0.70	0.75	0.80
A1	—	0.02	0.05
b	0.25	0.30	0.35
c	0.18	0.20	0.25
D	3.90	4.00	4.10
D2	2.10	2.20	2.30
E	3.90	4.00	4.10
E2	2.10	2.20	2.30
e	—	0.65	—
h	0.30	0.35	0.40
L	0.45	0.55	0.65
Nd	—	1.95	—
Ne	—	1.95	—

(Original dimensions are in millimeters)

Figure 9-2 QFN16 recommend footprint



(All dimensions are in millimeters)

9.2 Thermal characteristics

Thermal resistance is used to characterize the thermal performance of the package device, which is represented by the Greek letter “ Θ ”. For semiconductor devices, thermal resistance represents the steady-state temperature rise of the chip junction due to the heat dissipated on the chip surface.

Θ_{JA} : Thermal resistance, junction-to-ambient.

Θ_{JB} : Thermal resistance, junction-to-board.

Θ_{JC} : Thermal resistance, junction-to-case.

Ψ_{JB} : Thermal characterization parameter, junction-to-board.

Ψ_{JT} : Thermal characterization parameter, junction-to-top center.

$$\Theta_{JA} = (T_J - T_A)/P_D$$

$$\Theta_{JB} = (T_J - T_B)/P_D$$

$$\Theta_{JC} = (T_J - T_C)/P_D$$

Where, T_J = Junction temperature.

T_A = Ambient temperature

T_B = Board temperature

T_C = Case temperature which is monitoring on package surface

P_D = Total power dissipation

Θ_{JA} represents the resistance of the heat flows from the heating junction to ambient air. It is an indicator of package heat dissipation capability. Lower Θ_{JA} can be considerate as better overall thermal performance. Θ_{JA} is generally used to estimate junction temperature.

Θ_{JB} is used to measure the heat flow resistance between the chip surface and the PCB board.

Θ_{JC} represents the thermal resistance between the chip surface and the package top case.

Θ_{JC} is mainly used to estimate the heat dissipation of the system (using heat sink or other heat dissipation methods outside the device package).

Table 9-2 Package thermal characteristics⁽¹⁾

Symbol	Condition	Package	Value	Unit
Θ_{JA}	Natural convection, 2S2P PCB	QFN16	51.23	°C/W
Θ_{JB}	Cold plate, 2S2P PCB	QFN16	17.44	°C/W
Θ_{JC}	Cold plate, 2S2P PCB	QFN16	23.22	°C/W
Ψ_{JB}	Natural convection, 2S2P PCB	QFN16	17.61	°C/W
Ψ_{JT}	Natural convection, 2S2P PCB	QFN16	1.17	°C/W

(1) Thermal characteristics are based on simulation, and meet JEDEC specification.

10 Ordering information

Table 10-1 Part order code for GD30BC2501x

Ordering Code	Package	Package Type	Temperature Operating Range
GD30BC2501LRTR	QFN16	Green	Industrial -40°C to +85°C

11 Revision history

Table 11-1 Revision history

Revision No.	Description	Date
1.0	Initial Release	Mar.30, 2022

Important Notice

This document is the property of GigaDevice Semiconductor Inc. and its subsidiaries (the "Company"). This document, including any product of the Company described in this document (the "Product"), is owned by the Company under the intellectual property laws and treaties of the People's Republic of China and other jurisdictions worldwide. The Company reserves all rights under such laws and treaties and does not grant any license under its patents, copyrights, trademarks, or other intellectual property rights. The names and brands of third party referred thereto (if any) are the property of their respective owner and referred to for identification purposes only.

The Company makes no warranty of any kind, express or implied, with regard to this document or any Product, including, but not limited to, the implied warranties of merchantability and fitness for a particular purpose. The Company does not assume any liability arising out of the application or use of any Product described in this document. Any information provided in this document is provided only for reference purposes. It is the responsibility of the user of this document to properly design, program, and test the functionality and safety of any application made of this information and any resulting product. Except for customized products which has been expressly identified in the applicable agreement, the Products are designed, developed, and/or manufactured for ordinary business, industrial, personal, and/or household applications only. The Products are not designed, intended, or authorized for use as components in systems designed or intended for the operation of weapons, weapons systems, nuclear installations, atomic energy control instruments, combustion control instruments, airplane or spaceship instruments, transportation instruments, traffic signal instruments, life-support devices or systems, other medical devices or systems (including resuscitation equipment and surgical implants), pollution control or hazardous substances management, or other uses where the failure of the device or Product could cause personal injury, death, property or environmental damage ("Unintended Uses"). Customers shall take any and all actions to ensure using and selling the Products in accordance with the applicable laws and regulations. The Company is not liable, in whole or in part, and customers shall and hereby do release the Company as well as its suppliers and/or distributors from any claim, damage, or other liability arising from or related to all Unintended Uses of the Products. Customers shall indemnify and hold the Company as well as its suppliers and/or distributors harmless from and against all claims, costs, damages, and other liabilities, including claims for personal injury or death, arising from or related to any Unintended Uses of the Products.

Information in this document is provided solely in connection with the Products. The Company reserves the right to make changes, corrections, modifications or improvements to this document and Products and services described herein at any time, without notice.